

No. 733,613.

PATENTED JULY 14, 1903.

A. A. BALL, JR.
FLASH BOILER.

APPLICATION FILED APR. 6, 1902.

NO MODEL.

4 SHEETS—SHEET 1.

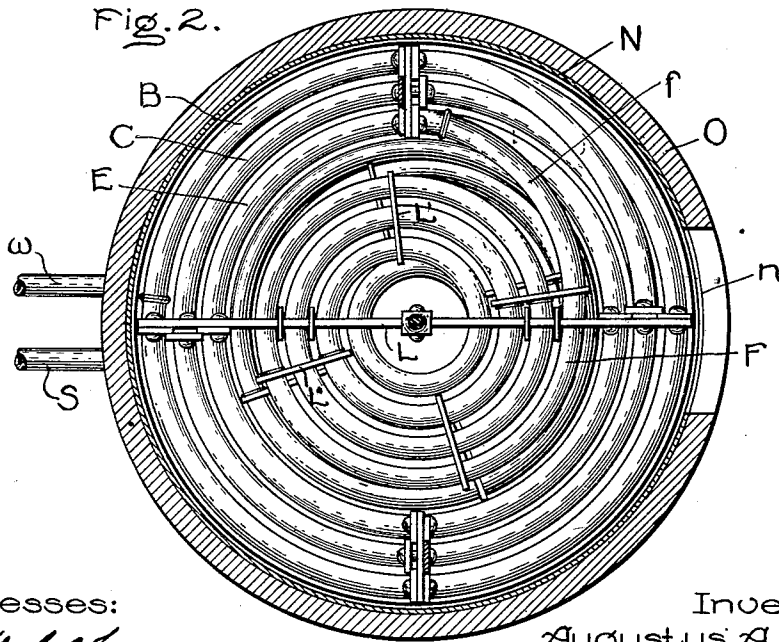
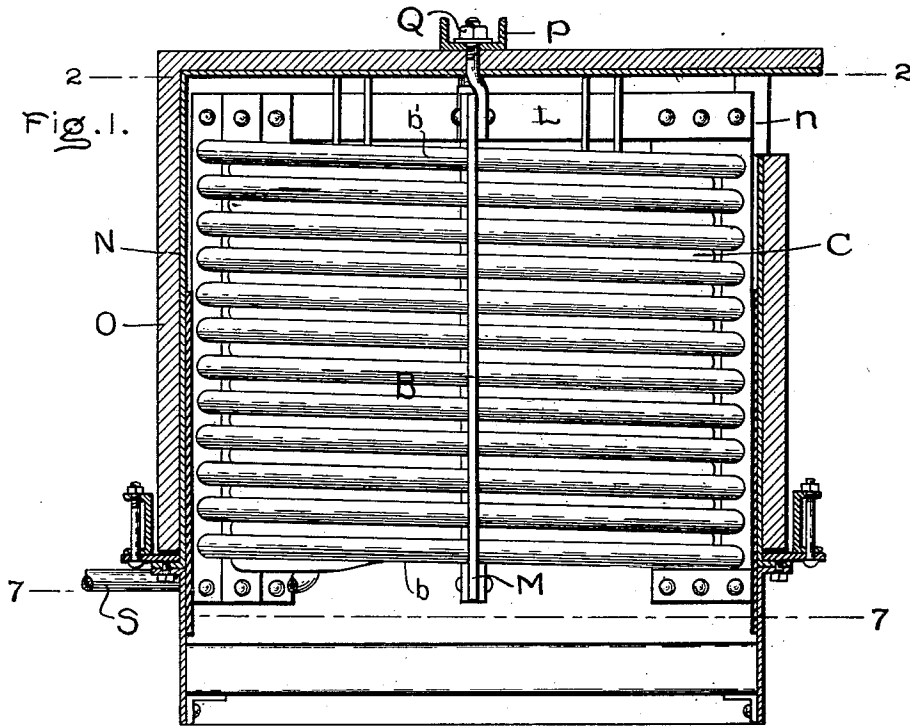

Witnesses:

Robt. Lehmann
Alex. Macdonald

Inventor,

Augustus A. Ball Jr.,

By *Albert G. Jain*
Att'y.

A. A. BALL, JR.

FLASH BOILER.

APPLICATION FILED APR. 8, 1902.

NO MODEL.

4 SHEETS—SHEET 2.

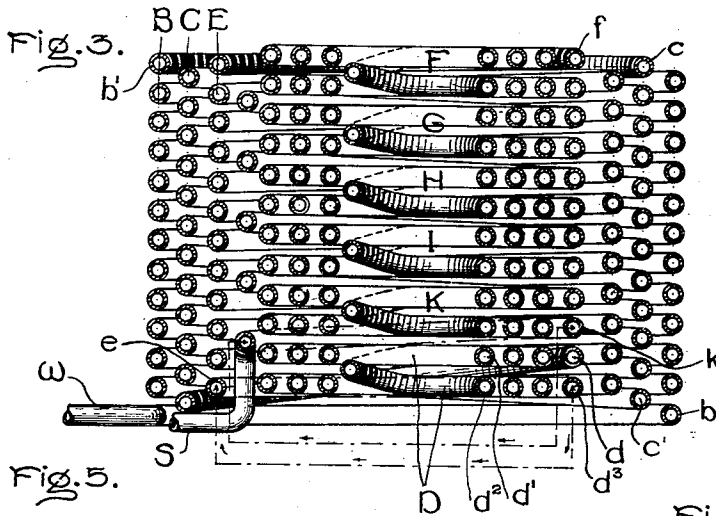

Fig. 5.

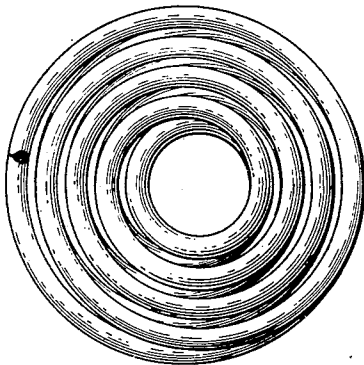

Fig. 6.

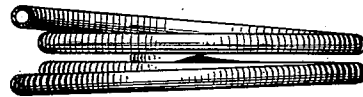
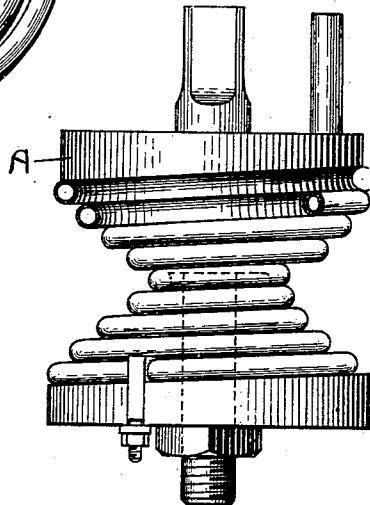

Fig. 4.



Witnesses:

Robt. C. Chapman
Alex. MacDonald

Inventor,
 Augustus A. Ball, Jr.,
 BY *Alb. H. Bain*
 Att'y.

A. A. BALL, JR.
FLASH BOILER.

APPLICATION FILED APR. 8, 1902.

NO MODEL.

4 SHEETS—SHEET 3.

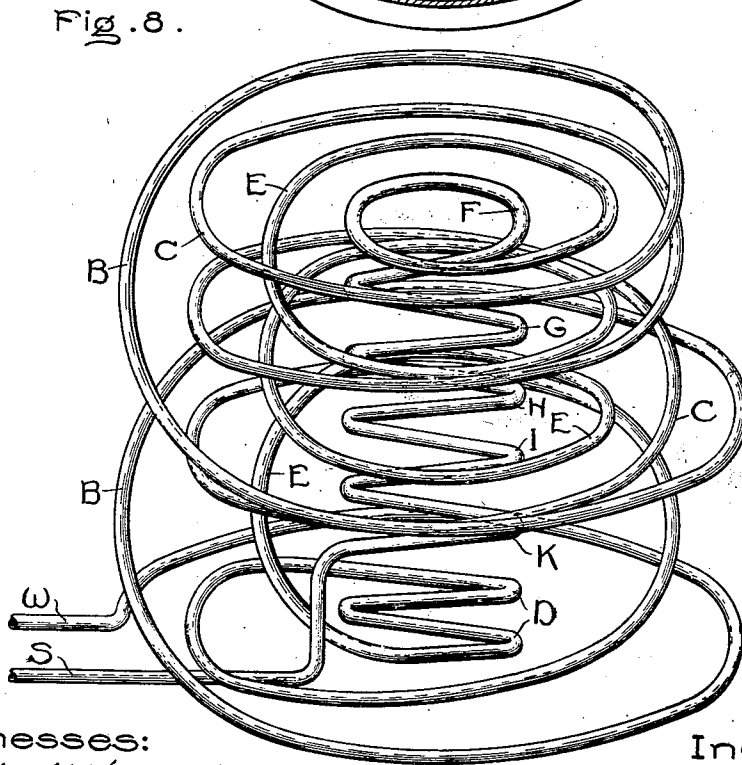
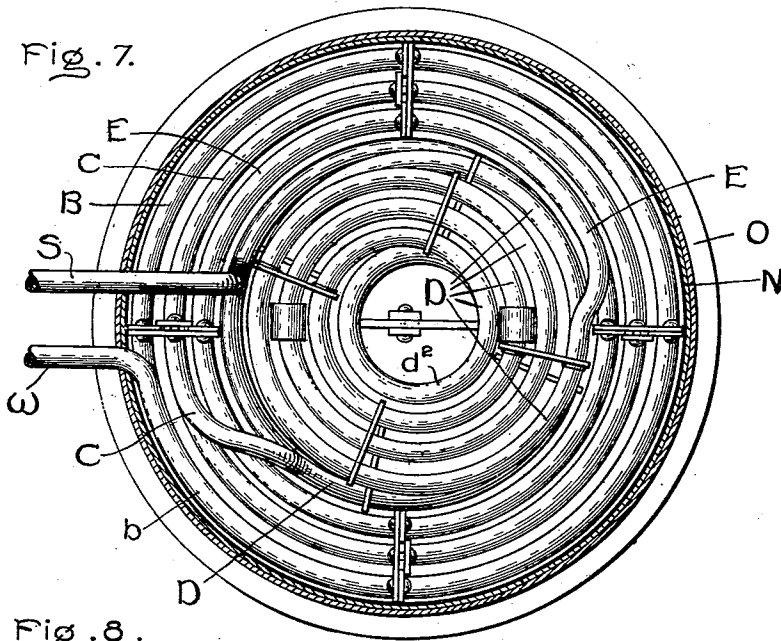

Witnesses:

Robt. Lehmann
Alex. Macdonald.

Inventor,
Augustus A. Ball Jr.,

By *Albion S. Davis*
Att'y.

A. A. BALL, JR.

FLASH BOILER.

APPLICATION FILED APR. 8, 1902.

NO MODEL.

4 SHEETS—SHEET 4.

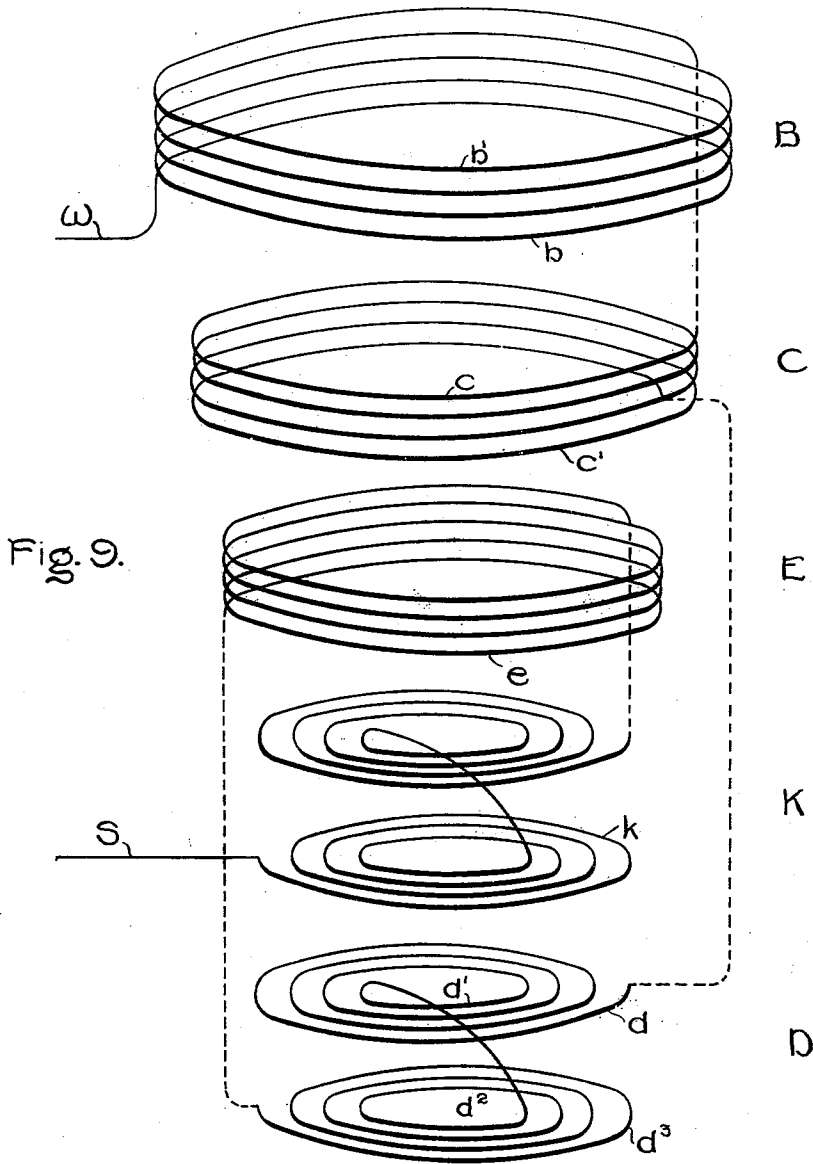

Fig. 9.

Witnesses.

Ewing R. Gurney.
Helen Orford

Inventor
Augustus A. Ball, Jr.
by *Albert B. Davis*
Atty.

UNITED STATES PATENT OFFICE.

AUGUSTUS A. BALL, JR., OF LYNN, MASSACHUSETTS, ASSIGNOR TO ELIHU THOMSON, OF SWAMPSCOTT, MASSACHUSETTS.

FLASH-BOILER.

SPECIFICATION forming part of Letters Patent No. 733,613, dated July 14, 1903.

Application filed April 8, 1902. Serial No. 101,871. (No model.)

To all whom it may concern:

Be it known that I, AUGUSTUS A. BALL, Jr., a citizen of the United States, residing at Lynn, in the county of Essex, State of Massachusetts, have invented certain new and useful Improvements in Flash-Boilers, of which the following is a specification.

This invention relates to steam-boilers; and its object is to furnish a light, simple, reliable, cheap, and efficient boiler of the flasher type in which the output may be varied through large limits and still maintain a high efficiency.

Another object is to furnish a boiler which can be readily cleaned, removed, replaced in whole or in part or quickly repaired or renewed.

Another object is to insure that the temperature of the gases circulating around and between its various parts shall be proportionate to the demand of said parts for heat in the various conditions of use.

Other objects and advantages will be pointed out hereinafter.

My invention consists in a boiler composed of a water-tube coiled into a small space in a peculiar manner and made either in a single integral length of tubing or in sections connected together, as may be desired. The water is introduced at such a point that it travels at first through a relatively cold part of the coil, and as its temperature rises it approaches a relatively warmer portion of the combustion-space, by which means the losses due to radiation and to excessive overheating at local points are largely avoided and the circulation is greatly accelerated. In order to raise steam in the shortest possible time and with the expenditure of a small amount of fuel, the discharge or steam end of the coil is located in or near the center of its horizontal axis and at or near the fire end of the boiler, which will be the lower end when an upright type is adopted. The turns in the pipe are all even and of good radius, avoiding sharp bends and elbows, which retard and disturb the circulation. The coil is supported inside a fire-box of suitable construction and in such a manner that it can be quickly assembled or taken apart.

In the accompanying drawings, Figure 1 is

a side elevation of my improved boiler with the fire-box and jacket in cross-section. Fig. 2 is a top plan sectional view on the line 2 2, Fig. 1. Fig. 3 is a vertical diametrical section of the coil. Fig. 4 is a side elevation of the former used in making the duplex spiral sections of the coil. Fig. 5 is a top plan view of one of said sections. Fig. 6 is a side elevation thereof. Fig. 7 is a bottom plan view on the line 7 7, Fig. 1. Fig. 8 is a perspective view of an elementary coil wound in accordance with my invention. Fig. 9 is a diagram showing the actual connections of the several coil-sections, but omitting those parts which are duplicated in Fig. 3.

The coil is made up of concentric helical portions and superposed duplex spiral portions, the latter being inside of the former. In this arrangement the water enters the outer one of the helical portions and the steam is drawn from an inner spiral portion. The helical portions are preferably cylindrical, as shown—that is to say, each turn of pipe lies in an upright cylindrical surface. The duplex spiral portions are each made up of two flat spirals connected at their inner turns. They can be conveniently made by winding a tube on an hour-glass-shaped former A, as shown in Fig. 4, and then flattening the coil thus formed into the shape shown in Figs. 5 and 6. While considerable variation can be made in grouping these helical and spiral portions and in the number of each kind that may be used, I prefer the arrangement shown in the drawings, where the feed-water delivered through the pipe W enters the lowest turn *b* of the outside helical portion B, through which it flows in an upward helical course to the upper turn *b'*, which merges into the upper turn *c* of the second or intermediate helical portion C, down through which it passes to the lowest turn *c'* thereof. The turn *c'* connects with the outer turn *d* of the upper half of the duplex spiral portion D, which is located at the fire end of the boiler in the center of the combustion-space. The water flows into the center turn *d'* of the upper half of the portion D, then to the center turn *d''* of the lower half of said portion, and out to the outer turn *d'''* of the same. Here it passes to the lower turn *e* of the third

or inner helical portion E, through which it rises to the top of the boiler and there enters the outer turn *f* of the upper half of the upper duplex spiral portion F. Its course through this portion is the same as through the portion D—that is to say, from the outside into the center in the upper half and from the center to the outside in the lower half. From the portion F the fluid passes to the next lower spiral portion G, and thence in succession to the portions H I K, as many or as few of these as may be desired being arranged in an upright tier, as shown. From the lowest outer turn *k* of the section K the steam is led away by the pipe S. In Fig. 9 the portions F G H I are omitted, and the boiler is shown as containing only two spiral portions D K. The several portions or sections are nested and are maintained in the proper relative position by long and short radial clamping-bars L L' and upright tie-rods M. They are inclosed in a fire-box N, which is covered with a non-conducting jacket O, of asbestos or the like. At one point at the top of the fire-box is left an opening *n* for the escape of the gases of combustion. The entire coil, with its clamping-bars and tie-rods, is suspended from a cross-girder P at the top of the fire-box and can be dropped out of said box by removing the nuts Q.

It will be observed that between the helical portions B C E, which surround the spiral portions, there are upright annular spaces affording a good passage for the hot gases. The turns of all portions are separated from each other, so that their entire surface is available for heating. The turns of each duplex spiral portion cross each other once, as shown in Fig. 5. This causes a deflection of the gases and brings them into intimate relation with these portions. The disposition of the pipes is such that sudden changes of temperature at any given part are avoided, so as to lessen the undesirable results due to sudden contraction or expansion.

It will be observed that the water passes first through the cooler portion B and is then brought through a warmer portion C to a hot portion D, thence up through a hotter portion E to the series of duplex spirals F G, &c., where it rapidly becomes vaporized as it passes down through the hottest part of the fire, the steam emerging at S in a superheated condition.

In accordance with the provisions of the patent statutes I have described the principle of operation of my invention, together with the apparatus which I now consider to represent the best embodiment thereof; but I desire to have it understood that the apparatus shown is only illustrative and that the invention can be carried out in other ways.

What I claim as new, and desire to secure by Letters Patent of the United States, is—

1. The herein-described boiler comprising a plurality of concentric helical portions situated one within the other, a plurality of du-

plex portions situated one above the other and located between the upper and lower ends of the helical portions, with vertically-extending flue-spaces formed between the helical and duplex portions, and connections between said portions whereby they are united to form a coil.

2. The herein-described boiler comprising a number of concentric helical portions, a connection extending to the outer of said portions, a number of duplex portions situated within the cylindrical space formed by the helical portions, a connection uniting the end of the inner concentric portion with the upper duplex portion, and a connection for carrying steam from the boiler, which is united to a lower duplex portion.

3. The herein-described boiler, comprising concentric helical portions and duplex spiral portions united to form a continuous tube, one of said spiral portions being connected between two of said helical portions.

4. The herein-described boiler, comprising concentric helical portions and duplex spiral portions, the latter arranged in an upright tier and the lower one being connected between two of the helical portions.

5. The herein-described boiler, comprising two outer concentric helical portions connected at their upper ends, a duplex spiral portion connected with the lower end of the inner helical portion, a third helical portion inside the others and connected at its lower end with the spiral portion, a tier of connected spiral portions connected at the upper end with the innermost helical portion, a feed-water pipe entering the lower end of the outer helical portion, and a steam-supply pipe connected with the lower end of the tier of spiral portions.

6. The herein-described boiler, comprising three concentric helical portions, the outer two being connected at their upper ends, and a tier of duplex spiral portions inside the helical portions and having their outer turns connected, the lower spiral being connected with the lower ends of the intermediate and inner helical portions, and the upper end of the inner helical portion being connected with the outer turn of the upper spiral portion.

7. A boiler comprising a coil of pipe made in nested portions or sections, clamping-bars and tie-rods which hold the portions or sections in fixed relation with respect to each other, a fire-box having an open end, and a means for suspending said clamped coil from the top of the box.

8. In combination, a coil of pipe, means attached to the coil to maintain the turns in definite relation, a casing which surrounds the coil and has an open lower end, means for supporting the casing in a fixed position, and devices which support the coil so that it can be removed without disturbing the casing by dropping it through the open end.

9. In combination, a coil of pipe, clamping means for holding the turns of the coil in

proper relation, connections for conveying liquid to the coil and delivering vapor therefrom, which are situated at one end of the coil, a casing for the coil, which has an open
5 end, a flue opening in said casing, permanent supports for the casing, a detachable means for closing an end of the casing, and supports for maintaining the coil in position, which are arranged to permit the coil and its con-

nections to be removed through the open end 10 of the casing without disturbing its supports.

In witness whereof I have hereunto set my hand this 5th day of April, 1902.

AUGUSTUS A. BALL, JR.

Witnesses:

DUGALD MCK. MCKILLOP,
JOHN A. MCMANUS.