

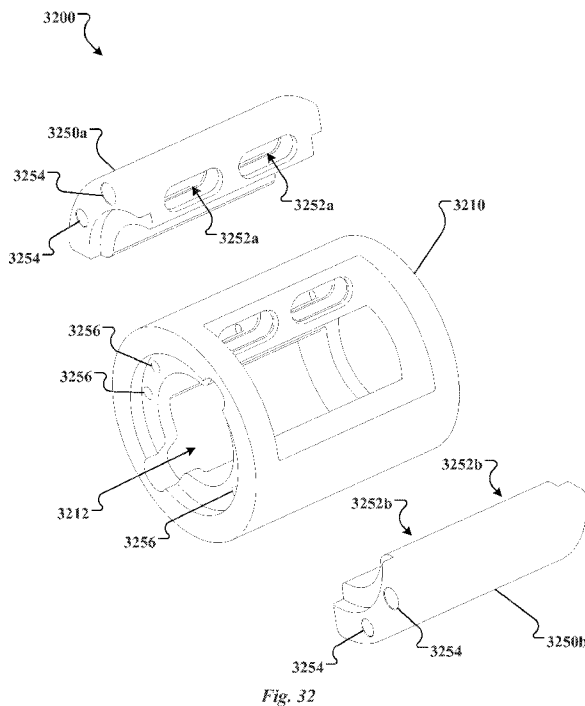

- (51) International Patent Classification: *F15B 15/12* (2006.01)
- (21) International Application Number: PCT/US2015/013895
- (22) International Filing Date: 30 January 2015 (30.01.2015)
- (25) Filing Language: English
- (26) Publication Language: English
- (30) Priority Data: 14/170,461 31 January 2014 (31.01.2014) US
- (71) Applicant: **WOODWARD, INC.** [US/US]; 1000 East Drake Road, Fort Collins, Colorado 80525 (US).
- (72) Inventors: **SOBOLEWSKI, Pawel A.**; 1310 S. Arlington Heights Road, Arlington Heights, Illinois 60005 (US). **KIM, Joseph H.**; 24558 Montevista Circle, Valencia, California 91354 (US). **SZULYK, Zenon P.**; 405 Craig Court, Mount Prospect, Illinois 60056 (US).
- (74) Agents: **MUSSELMAN, JR., P. Weston** et al.; Fish & Richardson P.C., P.O. Box 1022, Minneapolis, Minnesota 55440-1022 (US).
- (81) Designated States (*unless otherwise indicated, for every kind of national protection available*): AE, AG, AL, AM, AO, AT, AU, AZ, BA, BB, BG, BH, BN, BR, BW, BY, BZ, CA, CH, CL, CN, CO, CR, CU, CZ, DE, DK, DM, DO, DZ, EC, EE, EG, ES, FI, GB, GD, GE, GH, GM, GT, HN, HR, HU, ID, IL, IN, IR, IS, JP, KE, KG, KN, KP, KR, KZ, LA, LC, LK, LR, LS, LU, LY, MA, MD, ME, MG, MK, MN, MW, MX, MY, MZ, NA, NG, NI, NO, NZ, OM, PA, PE, PG, PH, PL, PT, QA, RO, RS, RU, RW, SA, SC, SD, SE, SG, SK, SL, SM, ST, SV, SY, TH, TJ, TM, TN, TR, TT, TZ, UA, UG, US, UZ, VC, VN, ZA, ZM, ZW.
- (84) Designated States (*unless otherwise indicated, for every kind of regional protection available*): ARIPO (BW, GH, GM, KE, LR, LS, MW, MZ, NA, RW, SD, SL, ST, SZ, TZ, UG, ZM, ZW), Eurasian (AM, AZ, BY, KG, KZ, RU, TJ, TM), European (AL, AT, BE, BG, CH, CY, CZ, DE, DK, EE, ES, FI, FR, GB, GR, HR, HU, IE, IS, IT, LT, LU, LV, MC, MK, MT, NL, NO, PL, PT, RO, RS, SE, SI, SK, SM, TR), OAPI (BF, BJ, CF, CG, CI, CM, GA, GN, GQ, GW, KM, ML, MR, NE, SN, TD, TG).

[Continued on next page]

(54) Title: ROTARY PISTON TYPE ACTUATOR WITH MODULAR HOUSING



(57) Abstract: A rotary actuator includes a piston housing assembly including a cavity, a fluid port in cavity, and an open end. A rotor assembly is rotatably journaled in the piston housing assembly and includes a rotary output shaft, a rotor arm extending radially outward from the rotary output shaft, an arcuate-shaped piston disposed in said piston housing assembly for reciprocal movement in the piston housing assembly through the open end along a radius of curvature. A seal, the cavity, and the piston define a pressure chamber, and a portion of the piston connects to the rotor arm at an end portion.



Declarations under Rule 4.17:

- *as to applicant's entitlement to apply for and be granted a patent (Rule 4.17(ii))*
- *as to the applicant's entitlement to claim the priority of the earlier application (Rule 4.17(iii))*

Published:

- *without international search report and to be republished upon receipt of that report (Rule 48.2(g))*

ROTARY PISTON TYPE ACTUATOR WITH MODULAR HOUSING

CLAIM OF PRIORITY

5

CROSS REFERENCE TO RELATED APPLICATIONS

[0001] This application claims priority to U.S. Patent Application No. 14/170,461 filed on January 31, 2014, which is a continuation in part of and claims the benefit of the priority to U.S. Patent Application No. 13/778,561, filed February 27, 2013, U.S. Patent Application No. 13/831,220, filed March 14, 2013, and U.S. Patent Application No. 13/921,904, filed June 19, 2013, the disclosures of which are incorporated by reference in their entirety.

TECHNICAL FIELD

[0002] This invention relates to an actuator device and more particularly to a rotary piston type actuator device wherein the pistons of the rotor are moved by fluid under pressure and wherein the actuator device includes a central actuation assembly adapted for attachment to and external mounting feature on a member to be actuated.

BACKGROUND

[0003] Rotary hydraulic actuators of various forms are currently used in industrial mechanical power conversion applications. This industrial usage is commonly for applications where continuous inertial loading is desired without the need for load holding for long durations, e.g. hours, without the use of an external fluid power supply. Aircraft flight control applications generally implement loaded positional holding, for example, in a failure mitigation mode, using substantially only the blocked fluid column to hold position.

[0004] In certain applications, such as primary flight controls used for aircraft operation, positional accuracy in load holding by rotary actuators is desired. Positional accuracy can be improved by minimizing internal leakage characteristics inherent to the design of rotary actuators. However, it can be difficult to provide leak-free performance in typical rotary hydraulic actuators, e.g., rotary "vane" or rotary "piston" type configurations.

SUMMARY

[0005] In general, this document relates to rotary actuators.

[0006] In a first aspect, a rotary actuator includes a housing, first piston housing assembly comprising a first cavity, a first fluid port in fluid communication with the first cavity, and a first open end, a second piston housing assembly comprising a second cavity, a second fluid port in fluid communication with the second cavity and a second open end, a rotor assembly rotatably journaled in said housing and comprising a rotary output shaft and a first rotor arm extending radially outward from the rotary output shaft to a first distal end, a second rotor arm extending radially outward from the rotary output shaft to a second distal end, and an arcuate-shaped first piston disposed in said first piston housing assembly for reciprocal movement in the first piston housing assembly through the first open end along a first radius of curvature, wherein a first seal, the first cavity, and the first piston define a first pressure chamber, and a first portion of the first piston connects to the first rotor arm at a first end portion, and an arcuate-shaped second piston disposed in said second piston housing assembly for reciprocal movement in the second piston housing assembly along the second radius of curvature, wherein a second seal, the second cavity, and the second piston define a second pressure chamber, and a second portion of the second piston connects to the second rotor arm at a second end portion. The first retainers and the second retainers are intermeshed along the radius of curvature such that movement of the rotor assembly urges movement of the first piston and movement of the first piston urges movement of the rotor assembly.

[0007] Various embodiments can include some, all, or none of the following features. The first distal end can comprise one or more first retainers, the second distal end can comprise one or more second retainers, the first end portion can comprise one or more third retainers and the second end portion can comprise one or more fourth retainers. The first retainers, the second retainers, the third retainers, and the fourth retainers can be intermeshed along the radius of curvature such that movement of the rotor assembly urges movement of the first piston and the second piston, and movement of the first piston and the second piston urges movement of the rotor assembly. The

rotary actuator can include a first connecting rod, and the first distal end can include a first bore, the first end portion can include a second bore, and the first connecting rod can be located within the first bore and the second bore when the first retainers and the third retainers are intermeshed. The rotary
5 actuator can include a second connecting rod and the second distal end can include a third bore, the second end portion can include a fourth bore, and the second connecting rod can be located within the third bore and the fourth bore when the second retainers and the fourth retainers are intermeshed. The second piston can be oriented in the same rotational direction as the first
10 piston. The second piston can be oriented in the opposite rotational direction as the first piston. The first piston housing assembly and the second piston housing assembly can be coupled to each other. The rotary actuator can include an outer housing having a bore, the first piston housing assembly and the second piston housing assembly being assembled to the outer housing
15 within the bore. The first piston housing assembly can be formed within the outer housing as a unitary housing. The first piston housing assembly can be located within a cavity of the outer housing formed as a unitary piston housing. The first piston housing assembly can be formed as a unitary piston housing, the second piston housing can be formed as a unitary piston housing, and the
20 outer housing can include a housing cavity formed to accommodate the first piston housing and the second piston housing. The first connecting rod, the first bore, and the second bore can be configured with cross-sectional geometries that prevent rotation of the first connecting rod within the first bore and the second bore around the longitudinal axis of the first connecting rod. At
25 least one of the first retainers and the second retainers or the third retainers and the fourth retainers can be formed with radial geometries that prevent rotation of the first piston away from the radius of curvature. At least one of the first retainers and the second retainers or the third retainers and the fourth retainers can be connected by one or more fasteners that prevent rotation of
30 the first piston away from the radius of curvature. The rotary actuator can include a second connecting rod and the first distal end can include a third bore, the first end portion can include a fourth bore, and the second connecting

rod can be located within the third bore and the fourth bore when the first retainers and the second retainers are intermeshed.

[0008] In a second aspect, a method of rotary actuation includes providing a rotary actuator comprising a housing, a first piston housing assembly
5 comprising a first cavity, a first fluid port in fluid communication with the first cavity, and a first open end, a second piston housing assembly comprising a second cavity, a second fluid port in fluid communication with the second cavity and a second open end, a rotor assembly rotatably journaled in said housing and comprising a rotary output shaft and a first rotor arm extending
10 radially outward from the rotary output shaft to a first distal end, a second rotor arm extending radially outward from the rotary output shaft to a second distal end, and an arcuate-shaped first piston disposed in said first piston housing assembly for reciprocal movement in the first piston housing assembly through the first open end along a first radius of curvature, wherein a first seal, the first cavity, and the first piston define a first pressure chamber, and a first
15 portion of the first piston connects to the first rotor arm at a first end portion, and an arcuate-shaped second piston disposed in said second piston housing assembly for reciprocal movement in the second piston housing assembly along the second radius of curvature, wherein a second seal, the second cavity, and the second piston define a second pressure chamber, and a
20 second portion of the second piston connects to the second rotor arm at a second end portion, wherein movement of the rotor assembly urges movement of the first piston and the second piston, and movement of the first piston and the second piston urges movement of the rotor assembly. The method also
25 includes urging a portion of the first piston partially out of the first pressure chamber to urge rotation of the rotary output shaft in a first direction, rotating the rotary output shaft in a second direction opposite that of the first direction, and urging the first piston partially into the first pressure chamber to urge pressurized fluid out the first fluid port.

[0009] Various implementations can include some, all, or none of the
30 following features. The first distal end can comprise one or more first retainers, the second distal end can comprise one or more second retainers, the first end portion can comprise one or more third retainers and the second

end portion can comprise one or more fourth retainers. The first retainers, the second retainers, the third retainers, and the fourth retainers can be intermeshed along the radius of curvature such that movement of the rotor assembly urges movement of the first piston and the second piston, and movement of the first piston and the second piston urges movement of the rotor assembly. The rotary actuator can include a first connecting rod and wherein the first distal end can include a first bore, the first end portion can include a second bore, and the first connecting rod can be located within the first bore and the second bore when the first retainers and the third retainers are intermeshed. The rotary actuator can include a second connecting rod and wherein the second distal end can include a third bore, the second end portion can include a fourth bore, and the second connecting rod can be located within the third bore and the fourth bore when the second retainers and the fourth retainers are intermeshed. The second piston can be oriented in the same rotational direction as the first piston. The second piston can be oriented in the opposite rotational direction as the first piston. The first piston housing assembly and the second piston housing assembly are coupled to each other. The rotary actuator can include an outer housing having a bore, the first piston housing assembly and the second piston housing assembly being assembled to the outer housing within the bore. The first piston housing assembly can be formed within the outer housing as a unitary housing. The first piston housing assembly can be located within a cavity of the outer housing formed as a unitary piston housing. The first piston housing assembly can be formed as a unitary piston housing, the second piston housing can be formed as a unitary piston housing, and the outer housing can include a housing cavity formed to accommodate the first piston housing and the second piston housing. The first connecting rod, the first bore, and the second bore can be configured with cross-sectional geometries that prevent rotation of the first connecting rod within the first bore and the second bore around the longitudinal axis of the first connecting rod. At least one of the first retainers and the second retainers or the third retainers and the fourth retainers can be formed with radial geometries that prevent rotation of the first piston away from the radius of curvature. At least one of the first retainers and the second retainers or the

third retainers and the fourth retainers can be connected by one or more fasteners that prevent rotation of the first piston away from the radius of curvature. The rotary actuator can include a second connecting rod and the first distal end can include a third bore, the first end portion can include a fourth bore, and the second connecting rod can be located within the third bore and the fourth bore when the first retainers and the second retainers are intermeshed.

[0010] In a third aspect, a rotary actuator includes a first piston housing assembly comprising a first cavity, a first fluid port in fluid communication with the first cavity, and a first open end, a second piston housing assembly comprising a second cavity, a second fluid port in fluid communication with the second cavity, and a second open end. A rotor assembly is rotatably journaled in said first piston housing assembly and said second piston housing assembly, and includes a rotary output shaft a first rotor arm extending radially outward from the rotary output shaft to a first distal end having one or more first retainers, a second rotor arm extending radially outward from the rotary output shaft to a second distal end comprising one or more second retainers, an arcuate-shaped first piston disposed in said first piston housing assembly for reciprocal movement in the first piston housing assembly through the first open end along a first radius of curvature, wherein a first seal, the first cavity, and the first piston define a first pressure chamber, and a first portion of the first piston connects to the first rotor arm at a first end portion comprising one or more third retainers, and an arcuate-shaped second piston disposed in said second piston housing assembly for reciprocal movement in the second piston housing assembly through the second open end along a second radius of curvature, wherein a second seal, the second cavity, and the second piston define a second pressure chamber, and a second portion of the second piston connects to the second rotor arm at a second end portion comprising one or more fourth retainers. The first retainers, the second retainers, the third retainers, and the fourth retainers are intermeshed along the radius of curvature such that movement of the rotor assembly urges movement of the first piston and the second piston, and movement of the first piston and the second piston urges movement of the rotor assembly.

[0011] Various embodiments can include some, all, or none of the following features. The second piston can be oriented in the same rotational direction as the first piston. The second piston can be oriented in the opposite rotational direction as the first piston. The rotary actuator can include a housing having a bore, the first piston housing assembly and the second piston housing assembly being assembled to the housing within the bore. The rotary actuator can include at least one end cap assembled to at least one axial end of the first piston housing assembly. The first piston housing assembly and the second piston housing assembly can be coupled to each other. The rotary actuator can also include a first connecting rod and the first distal end can include a first bore, the first end portion can include a second bore, and the first connecting rod can be located within the first bore and the second bore when the first retainers and the third retainers are intermeshed. The first connecting rod, the first bore, and the second bore can be configured with cross-sectional geometries that prevent rotation of the first connecting rod within the first bore and the second bore around the longitudinal axis of the first connecting rod. At least one of the first retainers and the second retainers or the third retainers and the fourth retainers can be formed with radial geometries that prevent rotation of the first piston or the second piston away from the radius of curvature. At least one of the first retainers and the second retainers or the third retainers and the fourth retainers can be connected by one or more fasteners that prevent rotation of the first piston or the second piston away from the radius of curvature. The rotary actuator can include a second connecting rod and the first distal end can include a third bore, the first end portion can include a fourth bore, and the second connecting rod can be located within the third bore and the fourth bore when the first retainers and the third retainers are intermeshed.

[0012] In a fourth aspect, a method of rotary actuation includes providing a rotary actuator that includes a first piston housing assembly comprising a first cavity, a first fluid port in fluid communication with the first cavity, and a first open end, a second piston housing assembly comprising a second cavity, a second fluid port in fluid communication with the second cavity, and a second open end. The actuator also includes a rotor assembly rotatably journaled in

said first piston housing assembly and said second piston housing assembly, and has a rotary output shaft, a first rotor arm extending radially outward from the rotary output shaft to a first distal end comprising one or more first retainers, a second rotor arm extending radially outward from the rotary output shaft to a second distal end, an arcuate-shaped first piston disposed in said first piston housing assembly for reciprocal movement in the first piston housing assembly through the first open end along a first radius of curvature, wherein a first seal, the first cavity, and the first piston define a first pressure chamber, and a first portion of the first piston connects to the first rotor arm at a first end portion comprising one or more second retainers, and an arcuate-shaped second piston disposed in said second piston housing assembly for reciprocal movement in the second piston housing assembly through the second open end along a second radius of curvature, wherein a second seal, the second cavity, and the second piston define a second pressure chamber, and a second portion of the second piston connects to the second rotor arm at a second end portion comprising one or more third retainers. The first retainers, the second retainers, and the third retainers are intermeshed along the radius of curvature such that movement of the rotor assembly urges movement of the first piston and the second piston, and movement of the first piston and the second piston urges movement of the rotor assembly. The method also includes urging a portion of the first piston partially out of the first pressure chamber to urge rotation of the rotary output shaft in a first direction, rotating the rotary output shaft in a second direction opposite that of the first direction, and urging the first piston partially into the first pressure chamber to urge pressurized fluid out the first fluid port.

[0013] Various implementations can include some, all, or none of the following features. The second piston can be oriented in the same rotational direction as the first piston. The second piston can be oriented in the opposite rotational direction as the first piston. The rotary actuator can include a housing having a bore, the first piston housing assembly and the second piston housing assembly being assembled to the housing within the bore. The rotary actuator can include at least one end cap assembled to at least one axial end of the first piston housing assembly. The first piston housing

assembly and the second piston housing assembly can be coupled to each other. The rotary actuator can include a first connecting rod and wherein the first distal end further comprises a first bore, the first end portion further comprises a second bore, and the first connecting rod is located within the first
5 bore and the second bore when the first retainers and the third retainers are intermeshed. The first connecting rod, the first bore, and the second bore can be configured with cross-sectional geometries that prevent rotation of the first connecting rod within the first bore and the second bore around the longitudinal axis of the first connecting rod. At least one of the first retainers
10 and the second retainers or the third retainers and the fourth retainers can be formed with radial geometries that prevent rotation of the first piston or the second piston away from the radius of curvature. At least one of the first retainers and the second retainers or the third retainers and the fourth retainers can be connected by one or more fasteners that prevent rotation of
15 the first piston or the second piston away from the radius of curvature. The rotary actuator can include a second connecting rod and the first distal end can include a third bore, the first end portion can include a fourth bore, and the second connecting rod can be located within the third bore and the fourth bore when the first retainers and the third retainers are intermeshed.

20 **[0014]** In a fifth aspect, a rotary actuator includes a first piston housing comprising a first cavity, a fluid port in fluid communication with the first cavity, and an open end, a housing assembly comprising a first outer housing comprising a first recess formed to partly accommodate the first piston housing, a second outer housing comprising a second recess formed to partly
25 accommodate the first piston housing, wherein the second outer housing is configured to be assembled to the outer housing such that the first recess and the second recess define a second cavity configured to accommodate the first piston housing, and an arcuate-shaped first piston disposed in said first piston housing for reciprocal movement in the first piston housing through the open
30 end along a radius of curvature, wherein a first seal, the first cavity, and the first piston define a pressure chamber.

The rotary actuator can further comprise a second piston housing comprising a third cavity, a fluid port in fluid communication with the third cavity, and an

open end, and a fluid conduit connecting the first cavity and the third cavity, wherein the second cavity is further configured to accommodate the second piston housing.

[0015] In a sixth aspect, a method of assembling a rotary actuator
5 comprises providing a first piston housing comprising a first cavity, a fluid port in fluid communication with the cavity, and an open end, providing a housing assembly comprising a first outer housing comprising a first recess formed to partly accommodate the first piston housing, a second outer housing
10 comprising a second recess formed to partly accommodate the first piston housing, wherein the second outer housing is configured to be assembled to the first piston housing such that the first recess and the second recess define a second cavity configured to accommodate the first piston housing, and providing an arcuate-shaped first piston disposed in said first piston housing for reciprocal movement in the first piston housing through the open end along
15 a radius of curvature, wherein a first seal, the first cavity, and the first piston define a first pressure chamber, inserting a portion of the first piston at least partly into the first pressure chamber; and positioning the first piston housing within the first recess and the second recess such that the second cavity is defined and the first piston housing is accommodated within the second cavity.
20 The method can further comprise providing a second piston housing comprising a third cavity, a fluid port in fluid communication with the cavity, and an open end, providing a fluid conduit connecting the first cavity and the third cavity, providing an arcuate-shaped second piston disposed in said second piston housing for reciprocal movement in the second piston housing through
25 the open end along a radius of curvature, wherein a second seal, the second cavity, and the second piston define a second pressure chamber; wherein the second cavity is further configured to accommodate the second piston housing, inserting a portion of the second piston at least partly into the second pressure chamber, and positioning the second piston housing within the first
30 recess and the second recess such that the second cavity is defined and the first piston housing and the second piston housing are accommodated within the second cavity.

[0016] The systems and techniques described herein may provide one or more of the following advantages. First, piston ends can be intermeshed with rotor arm ends to prevent separation of the pistons from the rotor arms.

5 Second, piston ends can be intermeshed with rotor arm ends to prevent a connector pin from becoming dislodged if the connector pin were to break. Third, modular piston housings can reduce the cost and/or complexity of rotary piston actuators.

[0017] The details of one or more implementations are set forth in the accompanying drawings and the description below. Other features and
10 advantages will be apparent from the description and drawings, and from the claims.

DESCRIPTION OF DRAWINGS

[0018] FIG. 1 is a perspective view of an example rotary piston-type actuator.

15 [0019] FIG. 2 is a perspective view of an example rotary piston assembly.

[0020] FIG. 3 is a perspective cross-sectional view of an example rotary piston-type actuator.

[0021] FIG. 4 is a perspective view of another example rotary piston-type actuator.

20 [0022] FIGs. 5 and 6 are cross-sectional views of an example rotary piston-type actuator.

[0023] FIG. 7 is a perspective view of another embodiment of a rotary piston-type actuator.

[0024] FIG. 8 is a perspective view of another example of a rotary piston-type actuator.
25

[0025] FIGs. 9 and 10 show an example rotary piston-type actuator in example extended and retracted configurations.

[0026] FIG. 11 is a perspective view of another example of a rotary piston-type actuator.

30 [0027] FIGs. 12-14 are perspective and cross-sectional views of another example rotary piston-type actuator.

[0028] FIGs. 15 and 16 are perspective and cross-sectional views of another example rotary piston-type actuator that includes another example rotary piston assembly.

[0029] FIGs. 17 and 18 are perspective and cross-sectional views of another example rotary piston-type actuator that includes another example rotary piston assembly.

[0030] FIGs. 19 and 20 are perspective and cross-sectional views of another example rotary piston-type actuator.

[0031] FIGs. 21A-21C are cross-sectional and perspective views of an example rotary piston.

[0032] FIGs. 22 and 23 illustrate a comparison of two example rotor shaft embodiments.

[0033] FIG. 24 is a perspective view of another example rotary piston.

[0034] FIG. 25 is a flow diagram of an example process for performing rotary actuation.

[0035] FIG. 26 is a perspective view of another example rotary piston-type actuator.

[0036] FIG. 27 is a cross-sectional view of another example rotary piston assembly.

[0037] FIG. 28 is a perspective cross-sectional view of another example rotary piston-type actuator.

[0038] FIG. 29A is a perspective view from above of an example rotary-piston type actuator with a central actuation assembly.

[0039] FIG. 29B is a top view of the actuator of FIG 29A.

[0040] FIG. 29C is a perspective view from the right side and above illustrating the actuator of FIG. 29A with a portion of the central actuation assembly removed for illustration purposes.

[0041] FIG. 29D is a lateral cross section view taken at section AA of the actuator of Fig 29B.

[0042] FIG. 29E is a partial perspective view from cross section AA of FIG. 29B.

[0043] FIG. 30A is a perspective view from above of an example rotary actuator with a central actuation assembly.

- [0044] FIG. 30B is another perspective view from above of the example rotary actuator of FIG. 30A.
- [0045] FIG. 30C is a top view of the example rotary actuator of FIG. 30A.
- [0046] FIG. 30D is an end view of the example rotary actuator of FIG. 30A.
- 5 [0047] FIG. 30E is a partial perspective view from cross section AA of FIG. 30C.
- [0048] FIG. 31A is a perspective view from above of another example rotary actuator with a central actuation assembly.
- [0049] FIG. 31B is another perspective view from above of the example rotary actuator of FIG. 31A.
- 10 [0050] FIG. 31C is a top view of the example rotary actuator of FIG. 31A.
- [0051] FIG. 31D is an end view of the example rotary actuator of FIG. 31A.
- [0052] FIG. 31E is a partial perspective view from cross section AA of FIG. 31C.
- 15 [0053] FIG. 32 is an exploded perspective view of another example pressure chamber assembly.
- [0054] FIGs. 33A-33C are exploded and assembled perspective views of another example rotary piston assembly.
- [0055] FIGs. 34A and 34B are perspective views of another example rotary piston.
- 20 [0056] FIG. 35A is a perspective view of another example pressure chamber assembly.
- [0057] FIG. 35B is a perspective partial cutaway view of the example pressure chamber assembly of FIG. 35A.
- 25 [0058] FIG. 35C is a perspective exploded view of the example pressure chamber assembly of FIG. 35A.
- [0059] FIG. 36 is a perspective view of an example piston housing assembly.

30

DETAILED DESCRIPTION

[0060] This document describes devices for producing rotary motion. In particular, this document describes devices that can convert fluid displacement

into rotary motion through the use of components more commonly used for producing linear motion, e.g., hydraulic or pneumatic linear cylinders. Vane-type rotary actuators are relatively compact devices used to convert fluid motion into rotary motion. Rotary vane actuators (RVA), however, generally use seals and component configurations that exhibit cross-vane leakage of the driving fluid. Such leakage can affect the range of applications in which such designs can be used. Some applications may require a rotary actuator to hold a rotational load in a selected position for a predetermined length of time, substantially without rotational movement, when the actuator's fluid ports are blocked. For example, some aircraft applications may require that an actuator hold a flap or other control surface that is under load (e.g., through wind resistance, gravity or g-forces) at a selected position when the actuator's fluid ports are blocked. Cross-vane leakage, however, can allow movement from the selected position.

[0061] Linear pistons use relatively mature sealing technology that exhibits well-understood dynamic operation and leakage characteristics that are generally better than rotary vane actuator type seals. Linear pistons, however, require additional mechanical components in order to adapt their linear motions to rotary motions. Such linear-to-rotary mechanisms are generally larger and heavier than rotary vane actuators that are capable of providing similar rotational actions, e.g., occupying a larger work envelope. Such linear-to-rotary mechanisms may also generally be installed in an orientation that is different from that of the load they are intended to drive, and therefore may provide their torque output indirectly, e.g., installed to push or pull a lever arm that is at a generally right angle to the axis of the axis of rotation of the lever arm. Such linear-to-rotary mechanisms may therefore become too large or heavy for use in some applications, such as aircraft control where space and weight constraints may make such mechanisms impractical for use.

[0062] In general, rotary piston assemblies use curved pressure chambers and curved pistons to controllably push and pull the rotor arms of a rotor assembly about an axis. In use, certain embodiments of the rotary piston assemblies described herein can provide the positional holding characteristics generally associated with linear piston-type fluid actuators, to rotary

applications, and can do so using the relatively more compact and lightweight envelopes generally associated with rotary vane actuators.

[0063] FIGs. 1-3 show various views of the components of an example rotary piston-type actuator 100. Referring to FIG. 1, a perspective view of the example rotary piston-type actuator 100 is shown. The actuator 100 includes a rotary piston assembly 200 and a pressure chamber assembly 300. The actuator 100 includes a first actuation section 110 and a second actuation section 120. In the example of actuator 100, the first actuation section 110 is configured to rotate the rotary piston assembly 200 in a first direction, e.g., counter-clockwise, and the second actuation section 120 is configured to rotate the rotary piston assembly 200 in a second direction substantially opposite the first direction, e.g., clockwise.

[0064] Referring now to FIG. 2, a perspective view of the example rotary piston assembly 200 is shown apart from the pressure chamber assembly 300. The rotary piston assembly 200 includes a rotor shaft 210. A plurality of rotor arms 212 extend radially from the rotor shaft 210, the distal end of each rotor arm 212 including a bore (not shown) substantially aligned with the axis of the rotor shaft 210 and sized to accommodate one of the collection of connector pins 214.

[0065] As shown in FIG. 2, the first actuation section 110 includes a pair of rotary pistons 250, and the second actuation section 120 includes a pair of rotary pistons 260. While the example actuator 100 includes two pairs of the rotary pistons 250, 260, other embodiments can include greater and/or lesser numbers of cooperative and opposing rotary pistons. Examples of other such embodiments will be discussed below, for example, in the descriptions of FIGs. 4-25.

[0066] In the example rotary piston assembly shown in FIG. 2, each of the rotary pistons 250, 260 includes a piston end 252 and one or more connector arms 254. The piston end 252 is formed to have a generally semi-circular body having a substantially smooth surface. Each of the connector arms 254 includes a bore 256 substantially aligned with the axis of the semi-circular body of the piston end 252 and sized to accommodate one of the connector pins 214.

[0067] The rotary pistons 260 in the example assembly of FIG. 2 are oriented substantially opposite each other in the same rotational direction. The rotary pistons 250 are oriented substantially opposite each other in the same rotational direction, but opposite that of the rotary pistons 260. In some
5 embodiments, the actuator 100 can rotate the rotor shaft 210 about 60 degrees total.

[0068] Each of the rotary pistons 250, 260 of the example assembly of FIG. 2 may be assembled to the rotor shaft 210 by aligning the connector arms 254 with the rotor arms 212 such that the bores (not shown) of the rotor arms 212
10 align with the bores 265. The connector pins 214 may then be inserted through the aligned bores to create hinged connections between the pistons 250, 260 and the rotor shaft 210. Each connector pin 214 is slightly longer than the aligned bores. In the example assembly, about the circumferential periphery of each end of each connector pin 214 that extends beyond the
15 aligned bores is a circumferential recess (not shown) that can accommodate a retaining fastener (not shown), e.g., a snap ring or spiral ring.

[0069] FIG. 3 is a perspective cross-sectional view of the example rotary piston-type actuator 100. The illustrated example shows the rotary pistons 260 inserted into a corresponding pressure chamber 310 formed as an arcuate
20 cavity in the pressure chamber assembly 300. The rotary pistons 250 are also inserted into corresponding pressure chambers 310, not visible in this view.

[0070] In the example actuator 100, each pressure chamber 310 includes a seal assembly 320 about the interior surface of the pressure chamber 310 at an open end 330. In some implementations, the seal assembly 320 can be a
25 circular or semi-circular sealing geometry retained on all sides in a standard seal groove. In some implementations, commercially available reciprocating piston or cylinder type seals can be used. For example, commercially available seal types that may already be in use for linear hydraulic actuators flying on current aircraft may demonstrate sufficient capability for linear load and
30 position holding applications. In some implementations, the sealing complexity of the actuator 100 may be reduced by using a standard, e.g., commercially available, semi-circular, unidirectional seal designs generally used in linear

hydraulic actuators. In some embodiments, the seal assembly 320 can be a one-piece seal.

[0071] In some embodiments of the example actuator 100, the seal assembly 320 may be included as part of the rotary pistons 250, 260. For example, the seal assembly 320 may be located near the piston end 252, 5 opposite the connector arm 254, and slide along the interior surface of the pressure chamber 310 to form a fluidic seal as the rotary piston 250, 260 moves in and out of the pressure chamber 310. An example actuator that uses such piston-mounted seal assemblies will be discussed in the descriptions of FIGs. 26-28. In some embodiments, the seal 310 can act as a 10 bearing. For example, the seal assembly 320 may provide support for the piston 250, 260 as it moves in and out of the pressure chamber 310.

[0072] In some embodiments, the actuator 100 may include a wear member between the piston 250, 260 and the pressure chamber 310. For example, a wear ring may be included in proximity to the seal assembly 320. 15 The wear ring may act as a pilot for the piston 250, 260, and/or act as a bearing providing support for the piston 250, 260.

[0073] In the example actuator 100, when the rotary pistons 250, 260 are inserted through the open ends 330, each of the seal assemblies 320 contacts 20 the interior surface of the pressure chamber 310 and the substantially smooth surface of the piston end 252 to form a substantially pressure-sealed region within the pressure chamber 310. Each of the pressure chambers 310 may include a fluid port 312 formed through the pressure chamber assembly 300, through which pressurized fluid may flow. Upon introduction of pressurized 25 fluid, e.g., hydraulic oil, water, air, gas, into the pressure chambers 310, the pressure differential between the interior of the pressure chambers 310 and the ambient conditions outside the pressure chambers 310 causes the piston ends 252 to be urged outward from the pressure chambers 310. As the piston ends 252 are urged outward, the pistons 250, 260 urge the rotary piston assembly 200 to rotate. 30

[0074] In the example of the actuator 100, cooperative pressure chambers may be fluidically connected by internal or external fluid ports. For example, the pressure chambers 310 of the first actuation section 110 may be fluidically

interconnected to balance the pressure between the pressure chambers 310. Similarly the pressure chambers 310 of the second actuation section 120 may be fluidically interconnected to provide similar pressure balancing. In some embodiments, the pressure chambers 310 may be fluidically isolated from each other. For example, the pressure chambers 310 may each be fed by an independent supply of pressurized fluid.

[0075] In the example of the actuator 100, the use of the alternating arcuate, e.g., curved, rotary pistons 250, 260 arranged substantially opposing each other operates to translate the rotor arms in an arc-shaped path about the axis of the rotary piston assembly 200, thereby rotating the rotor shaft 210 clockwise and counter-clockwise in a substantially torque balanced arrangement. Each cooperative pair of pressure chambers 310 operates unidirectionally in pushing the respective rotary piston 250 outward, e.g., extension, to drive the rotor shaft 210 in the specific direction. To reverse direction, the opposing cylinder section's 110 pressure chambers 260 are pressurized to extend their corresponding rotary pistons 260 outward.

[0076] The pressure chamber assembly 300, as shown, includes a collection of openings 350. In general, the openings 350 provide space in which the rotor arms 212 can move when the rotor shaft 210 is partly rotated. In some implementations, the openings 350 can be formed to remove material from the pressure chamber assembly 300, e.g., to reduce the mass of the pressure chamber assembly 300. In some implementations, the openings 350 can be used during the process of assembly of the actuator 100. For example, the actuator 100 can be assembled by inserting the rotary pistons 250, 260 through the openings 350 such that the piston ends 252 are inserted into the pressure chambers 310. With the rotary pistons 250, 260 substantially fully inserted into the pressure chambers 310, the rotor shaft 210 can be assembled to the actuator 100 by aligning the rotor shaft 210 with an axial bore 360 formed along the axis of the pressure chamber assembly 300, and by aligning the rotor arms 212 with a collection of keyways 362 formed along the axis of the pressure chamber assembly 300. The rotor shaft 210 can then be inserted into the pressure chamber assembly 300. The rotary pistons 250, 260 can be partly extracted from the pressure chambers 310 to substantially align

the bores 256 with the bores of the rotor arms 212. The connector pins 214 can then be passed through the keyways 362 and the aligned bores to connect the rotary pistons 250, 260 to the rotor shaft 210. The connector pins 214 can be secured longitudinally by inserting retaining fasteners through the openings 5 350 and about the ends of the connector pins 214. The rotor shaft 210 can be connected to an external mechanism as an output shaft in order to transfer the rotary motion of the actuator 100 to other mechanisms. A bushing or bearing 362 is fitted between the rotor shaft 210 and the axial bore 360 at each end of the pressure chamber assembly 300.

10 **[0077]** In some embodiments, the rotary pistons 250, 260 may urge rotation of the rotor shaft 210 by contacting the rotor arms 212. For example, the piston ends 252 may not be coupled to the rotor arms 212. Instead, the piston ends 252 may contact the rotor arms 212 to urge rotation of the rotor shaft as the rotary pistons 250, 260 are urged outward from the pressure chambers 15 310. Conversely, the rotor arms 212 may contact the piston ends 252 to urge the rotary pistons 250, 260 back into the pressure chambers 310.

[0078] In some embodiments, a rotary position sensor assembly (not shown) may be included in the actuator 100. For example, an encoder may be used to sense the rotational position of the rotor shaft 210 relative to the 20 pressure chamber assembly or another feature that remains substantially stationary relative to the rotation of the shaft 210. In some implementations, the rotary position sensor may provide signals that indicate the position of the rotor shaft 210 to other electronic or mechanical modules, e.g., a position controller.

25 **[0079]** In use, pressurized fluid in the example actuator 100 can be applied to the pressure chambers 310 of the second actuation section 120 through the fluid ports 312. The fluid pressure urges the rotary pistons 260 out of the pressure chambers 310. This movement urges the rotary piston assembly 200 to rotate clockwise. Pressurized fluid can be applied to the pressure chambers 30 310 of the first actuation section 110 through the fluid ports 312. The fluid pressure urges the rotary pistons 250 out of the pressure chambers 310. This movement urges the rotary piston assembly 200 to rotate counter-clockwise. The fluid conduits can also be blocked fluidically to cause the rotary piston

assembly 200 to substantially maintain its rotary position relative to the pressure chamber assembly 300.

[0080] In some embodiments of the example actuator 100, the pressure chamber assembly 300 can be formed from a single piece of material. For example, the pressure chambers 310, the openings 350, the fluid ports 312, the keyways 362, and the axial bore 360 may be formed by molding, machining, or otherwise forming a unitary piece of material.

[0081] FIG. 4 is a perspective view of another example rotary piston-type actuator 400. In general, the actuator 400 is similar to the actuator 100, but instead of using opposing pairs of rotary pistons 250, 260, each acting unidirectionally to provide clockwise and counter-clockwise rotation, the actuator 400 uses a pair of bidirectional rotary pistons.

[0082] As shown in FIG. 4, the actuator 400 includes a rotary piston assembly that includes a rotor shaft 412 and a pair of rotary pistons 414. The rotor shaft 412 and the rotary pistons 414 are connected by a pair of connector pins 416.

[0083] The example actuator shown in FIG. 4 includes a pressure chamber assembly 420. The pressure chamber assembly 420 includes a pair of pressure chambers 422 formed as arcuate cavities in the pressure chamber assembly 420. Each pressure chamber 422 includes a seal assembly 424 about the interior surface of the pressure chamber 422 at an open end 426. The seal assemblies 424 contact the inner walls of the pressure chambers 422 and the rotary pistons 414 to form fluidic seals between the interiors of the pressure chambers 422 and the space outside. A pair of fluid ports 428 is in fluidic communication with the pressure chambers 422. In use, pressurized fluid can be applied to the fluid ports 428 to urge the rotary pistons 414 partly out of the pressure chambers 422, and to urge the rotor shaft 412 to rotate in a first direction, e.g., clockwise in this example.

[0084] The pressure chamber assembly 420 and the rotor shaft 412 and rotary pistons 414 of the rotary piston assembly may be structurally similar to corresponding components found in to the second actuation section 120 of the actuator 100. In use, the example actuator 400 also functions substantially similarly to the actuator 100 when rotating in a first direction when the rotary

pistons 414 are being urged outward from the pressure chambers 422. e.g., clockwise in this example. As will be discussed next, the actuator 400 differs from the actuator 100 in the way that the rotor shaft 412 is made to rotate in a second direction, e.g., counter-clockwise in this example.

5 **[0085]** To provide actuation in the second direction, the example actuator 400 includes an outer housing 450 with a bore 452. The pressure chamber assembly 420 is formed to fit within the bore 452. The bore 452 is fluidically sealed by a pair of end caps (not shown). With the end caps in place, the bore 452 becomes a pressurizable chamber. Pressurized fluid can flow to and from
10 the bore 452 through a fluid port 454. Pressurized fluid in the bore 452 is separated from fluid in the pressure chambers 422 by the seals 426.

[0086] Referring now to FIG. 5, the example actuator 400 is shown in a first configuration in which the rotor shaft 412 has been rotated in a first direction, e.g., clockwise, as indicated by the arrows 501. The rotor shaft 412 can be
15 rotated in the first direction by flowing pressurized fluid into the pressure chambers 422 through the fluid ports 428, as indicated by the arrows 502. The pressure within the pressure chambers 422 urges the rotary pistons 414 partly outward from the pressure chambers 422 and into the bore 452. Fluid within the bore 452, separated from the fluid within the pressure chambers 422 by
20 the seals 424 and displaced by the movement of the rotary pistons 414, is urged to flow out the fluid port 454, as indicated by the arrow 503.

[0087] Referring now to FIG. 6, the example actuator 400 is shown in a second configuration in which the rotor shaft 412 has been rotated in a second direction, e.g., counter-clockwise, as indicated by the arrows 601. The rotor
25 shaft 412 can be rotated in the second direction by flowing pressurized fluid into the bore 452 through the fluid port 454, as indicated by the arrow 602. The pressure within the bore 452 urges the rotary pistons 414 partly into the pressure chambers 422 from the bore 452. Fluid within the pressure chambers 422, separated from the fluid within the bore 452 by the seals 424
30 and displaced by the movement of the rotary pistons 414, is urged to flow out the fluid ports 428, as indicated by the arrows 603. In some embodiments, one or more of the fluid ports 428 and 454 can be oriented radially relative to the axis of the actuator 400, as illustrated in FIGs. 4-6, however in some

embodiments one or more of the fluid ports 428 and 454 can be oriented parallel to the axis of the actuator 400 or in any other appropriate orientation.

[0088] FIG. 7 is a perspective view of another embodiment of a rotary piston assembly 700. In the example actuator 100 of FIG. 1, two opposing pairs of rotary pistons were used, but in other embodiments other numbers and configurations of rotary pistons and pressure chambers can be used. In the example of the assembly 700, a first actuation section 710 includes four rotary pistons 712 cooperatively operable to urge a rotor shaft 701 in a first direction. A second actuation section 720 includes four rotary pistons 722 cooperatively operable to urge the rotor shaft 701 in a second direction.

[0089] Although examples using four rotary pistons, e.g., actuator 100, and eight rotary pistons, e.g., assembly 700, have been described, other configurations may exist. In some embodiments, any appropriate number of rotary pistons may be used in cooperation and/or opposition. In some embodiments, opposing rotary pistons may not be segregated into separate actuation sections, e.g., the actuation sections 710 and 720. While cooperative pairs of rotary pistons are used in the examples of actuators 100, 400, and assembly 700, other embodiments exist. For example, clusters of two, three, four, or more cooperative or oppositional rotary pistons and pressure chambers may be arranged radially about a section of a rotor shaft. As will be discussed in the descriptions of FIGs. 8-10, a single rotary piston may be located at a section of a rotor shaft. In some embodiments, cooperative rotary pistons may be interspersed alternately with opposing rotary pistons. For example, the rotary pistons 712 may alternate with the rotary pistons 722 along the rotor shaft 701.

[0090] FIG. 8 is a perspective view of another example of a rotary piston-type actuator 800. The actuator 800 differs from the example actuators 100 and 400, and the example assembly 700 in that instead of implementing cooperative pairs of rotary pistons along a rotor shaft, e.g., two of the rotary pistons 250 are located radially about the rotor shaft 210, individual rotary pistons are located along a rotor shaft.

[0091] The example actuator 800 includes a rotor shaft 810 and a pressure chamber assembly 820. The actuator 800 includes a first actuation section

801 and a second actuation section 802. In the example actuator 800, the first actuation section 801 is configured to rotate the rotor shaft 810 in a first direction, e.g., clockwise, and the second actuation section 802 is configured to rotate the rotor shaft 810 in a second direction substantially opposite the first direction, e.g., counter-clockwise.

[0092] The first actuation section 801 of example actuator 800 includes a rotary piston 812, and the second actuation section 802 includes a rotary piston 822. By implementing a single rotary piston 812, 822 at a given longitudinal position along the rotor shaft 810, a relatively greater range of rotary travel may be achieved compared to actuators that use pairs of rotary pistons at a given longitudinal position along the rotary piston assembly, e.g., the actuator 100. In some embodiments, the actuator 800 can rotate the rotor shaft 810 about 145 degrees total.

[0093] In some embodiments, the use of multiple rotary pistons 812, 822 along the rotor shaft 810 can reduce distortion of the pressure chamber assembly 820, e.g., reduce bowing out under high pressure. In some embodiments, the use of multiple rotary pistons 812, 822 along the rotor shaft 810 can provide additional degrees of freedom for each piston 812, 822. In some embodiments, the use of multiple rotary pistons 812, 822 along the rotor shaft 810 can reduce alignment issues encountered during assembly or operation. In some embodiments, the use of multiple rotary pistons 812, 822 along the rotor shaft 810 can reduce the effects of side loading of the rotor shaft 810.

[0094] FIG. 9 shows the example actuator 800 with the rotary piston 812 in a substantially extended configuration. A pressurized fluid is applied to a fluid port 830 to pressurize an arcuate pressure chamber 840 formed in the pressure chamber assembly 820. Pressure in the pressure chamber 840 urges the rotary piston 812 partly outward, urging the rotor shaft 810 to rotate in a first direction, e.g., clockwise.

[0095] FIG. 10 shows the example actuator 800 with the rotary piston 812 in a substantially retracted configuration. Mechanical rotation of the rotor shaft 810, e.g., pressurization of the actuation section 820, urges the rotary piston

812 partly inward, e.g., clockwise. Fluid in the pressure chamber 840 displaced by the rotary piston 812 flows out through the fluid port 830.

[0096] The example actuator 800 can be assembled by inserting the rotary piston 812 into the pressure chamber 840. Then the rotor shaft 810 can be inserted longitudinally through a bore 850 and a keyway 851. The rotary piston 812 is connected to the rotor shaft 810 by a connecting pin 852.

[0097] FIG. 11 is a perspective view of another example of a rotary piston-type actuator 1100. In general, the actuator 1100 is similar to the example actuator 800, except multiple rotary pistons are used in each actuation section.

[0098] The example actuator 1100 includes a rotary piston assembly 1110 and a pressure chamber assembly 1120. The actuator 1100 includes a first actuation section 1101 and a second actuation section 1102. In the example of actuator 1100, the first actuation section 1101 is configured to rotate the rotary piston assembly 1110 in a first direction, e.g., clockwise, and the second actuation section 1102 is configured to rotate the rotary piston assembly 1110 in a second direction substantially opposite the first direction, e.g., counter-clockwise.

[0099] The first actuation section 1101 of example actuator 1100 includes a collection of rotary pistons 812, and the second actuation section 1102 includes a collection of rotary pistons 822. By implementing individual rotary pistons 812, 822 at various longitudinal positions along the rotary piston assembly 1110, a range of rotary travel similar to the actuator 800 may be achieved. In some embodiments, the actuator 1100 can rotate the rotor shaft 1110 about 60 degrees total.

[00100] In some embodiments, the use of the collection of rotary pistons 812 may provide mechanical advantages in some applications. For example, the use of multiple rotary pistons 812 may reduce stress or deflection of the rotary piston assembly, may reduce wear of the seal assemblies, or may provide more degrees of freedom. In another example, providing partitions, e.g., webbing, between chambers can add strength to the pressure chamber assembly 1120 and can reduce bowing out of the pressure chamber assembly 1120 under high pressure. In some embodiments, placement of an end tab on

the rotor shaft assembly 1110 can reduce cantilever effects experienced by the actuator 800 while under load, e.g., less stress or bending.

[00101] FIGs. 12-14 are perspective and cross-sectional views of another example rotary piston-type actuator 1200. The actuator 1200 includes a rotary piston assembly 1210, a first actuation section 1201, and a second actuation section 1202.

[00102] The rotary piston assembly 1210 of example actuator 1200 includes a rotor shaft 1212, a collection of rotor arms 1214, and a collection of dual rotary pistons 1216. Each of the dual rotary pistons 1216 includes a connector section 1218 a piston end 1220a and a piston end 1220b. The piston ends 1220a-1220b are arcuate in shape, and are oriented opposite to each other in a generally semicircular arrangement, and are joined at the connector section 1218. A bore 1222 is formed in the connector section 1218 and is oriented substantially parallel to the axis of the semicircle formed by the piston ends 1220a-1220b. The bore 1222 is sized to accommodate a connector pin (not shown) that is passed through the bore 1222 and a collection of bores 1224 formed in the rotor arms 1213 to secure each of the dual rotary pistons 1216 to the rotor shaft 1212.

[00103] The first actuation section 1201 of example actuator 1200 includes a first pressure chamber assembly 1250a, and the second actuation section 1202 includes a second pressure chamber assembly 1250b. The first pressure chamber assembly 1250a includes a collection of pressure chambers 1252a formed as arcuate cavities in the first pressure chamber assembly 1250a. The second pressure chamber assembly 1250b includes a collection of pressure chambers 1252b formed as arcuate cavities in the first pressure chamber assembly 1250b. When the pressure chamber assemblies 1250a-1250b are assembled into the actuator 1200, each of the pressure chambers 1252a lies generally in a plane with a corresponding one of the pressure chambers 1252b, such that a pressure chamber 1252a and a pressure chamber 1252b occupy two semicircular regions about a central axis. A semicircular bore 1253a and a semicircular bore 1253b substantially align to accommodate the rotor shaft 1212.

[00104] Each of the pressure chambers 1252a-1252b of example actuator 1200 includes an open end 1254 and a seal assembly 1256. The open ends 1254 are formed to accommodate the insertion of the piston ends 1220a-1220b. The seal assemblies 1256 contact the inner walls of the pressure chambers 1252a-1252b and the outer surfaces of the piston ends 1220a-1220b to form a fluidic seal.

[00105] The rotary piston assembly 1210 of example actuator 1200 can be assembled by aligning the bores 1222 of the dual rotary pistons 1216 with the bores 1224 of the rotor arms 1214. The connector pin (not shown) is passed through the bores 1222 and 1224 and secured longitudinally by retaining fasteners.

[00106] The example actuator 1200 can be assembled by positioning the rotor shaft 1212 substantially adjacent to the semicircular bore 1253a and rotating it to insert the piston ends 1220a substantially fully into the pressure chambers 1252a. The second pressure chamber 1252b is positioned adjacent to the first pressure chamber 1252a such that the semicircular bore 1253b is positioned substantially adjacent to the rotor shaft 1212. The rotary piston assembly 1210 is then rotated to partly insert the piston ends 1220b into the pressure chambers 1252b. An end cap 1260 is fastened to the longitudinal ends 1262a of the pressure chambers 1252a-1252b. A second end cap (not shown) is fastened to the longitudinal ends 1262b of the pressure chambers 1252a-1252b. The end caps substantially maintain the positions of the rotary piston assembly 1210 and the pressure chambers 1252a-1252b relative to each other. In some embodiments, the actuator 1200 can provide about 90 degrees of total rotational stroke.

[00107] In operation, pressurized fluid is applied to the pressure chambers 1252a of example actuator 1200 to rotate the rotary piston assembly 1210 in a first direction, e.g., clockwise. Pressurized fluid is applied to the pressure chambers 1252b to rotate the rotary piston assembly 1210 in a second direction, e.g., counter-clockwise.

[00108] FIGs. 15 and 16 are perspective and cross-sectional views of another example rotary piston-type actuator 1500 that includes another example rotary piston assembly 1501. In some embodiments, the assembly

1501 can be an alternative embodiment of the rotary piston assembly 200 of FIG. 2.

[00109] The assembly 1501 of example actuator 1500 includes a rotor shaft 1510 connected to a collection of rotary pistons 1520a and a collection of rotary pistons 1520b by a collection of rotor arms 1530 and one or more connector pins (not shown). The rotary pistons 1520a and 1520b are arranged along the rotor shaft 1510 in a generally alternating pattern, e.g., one rotary piston 1520a, one rotary piston 1520b, one rotary piston 1520a, one rotary piston 1520b. In some embodiments, the rotary pistons 1520a and 1520b may be arranged along the rotor shaft 1510 in a generally intermeshed pattern, e.g., one rotary piston 1520a and one rotary piston 1520b rotationally parallel to each other, with connector portions formed to be arranged side-by-side or with the connector portion of rotary piston 1520a formed to one or more male protrusions and/or one or more female recesses to accommodate one or more corresponding male protrusions and/or one or more corresponding female recesses formed in the connector portion of the rotary piston 1520b.

[00110] Referring to FIG. 16, a pressure chamber assembly 1550 of example actuator 1500 includes a collection of arcuate pressure chambers 1555a and a collection of arcuate pressure chambers 1555b. The pressure chambers 1555a and 1555b are arranged in a generally alternating pattern corresponding to the alternating pattern of the rotary pistons 1520a-1520b. The rotary pistons 1520a-1520b extend partly into the pressure chambers 1555a-1555b. A seal assembly 1560 is positioned about an open end 1565 of each of the pressure chambers 1555a-1555b to form fluidic seals between the inner walls of the pressure chambers 1555a-1555b and the rotary pistons 1520a-1520b.

[00111] In use, pressurized fluid can be alternatingly provided to the pressure chambers 1555a and 1555b of example actuator 1500 to urge the rotary piston assembly 1501 to rotate partly clockwise and counterclockwise. In some embodiments, the actuator 1500 can rotate the rotor shaft 1510 about 92 degrees total.

[00112] FIGs. 17 and 18 are perspective and cross-sectional views of another example rotary piston-type actuator 1700 that includes another

example rotary piston assembly 1701. In some embodiments, the assembly 1701 can be an alternative embodiment of the rotary piston assembly 200 of FIG. 2 or the assembly 1200 of FIG. 12.

[00113] The assembly 1701 of example actuator 1700 includes a rotor shaft 1710 connected to a collection of rotary pistons 1720a by a collection of rotor arms 1730a and one or more connector pins 1732. The rotor shaft 1710 is also connected to a collection of rotary pistons 1720b by a collection of rotor arms 1730b and one or more connector pins 1732. The rotary pistons 1720a and 1720b are arranged along the rotor shaft 1710 in a generally opposing, symmetrical pattern, e.g., one rotary piston 1720a is paired with one rotary piston 1720b at various positions along the length of the assembly 1701.

[00114] Referring to FIG. 18, a pressure chamber assembly 1750 of example actuator 1700 includes a collection of arcuate pressure chambers 1755a and a collection of arcuate pressure chambers 1755b. The pressure chambers 1755a and 1755b are arranged in a generally opposing, symmetrical pattern corresponding to the symmetrical arrangement of the rotary pistons 1720a-1720b. The rotary pistons 1720a-1720b extend partly into the pressure chambers 1755a-1755b. A seal assembly 1760 is positioned about an open end 1765 of each of the pressure chambers 1755a-1755b to form fluidic seals between the inner walls of the pressure chambers 1755a-1755b and the rotary pistons 1720a-1720b.

[00115] In use, pressurized fluid can be alternatingly provided to the pressure chambers 1755a and 1755b of example actuator 1700 to urge the rotary piston assembly 1701 to rotate partly clockwise and counterclockwise. In some embodiments, the actuator 1700 can rotate the rotor shaft 1710 about 52 degrees total.

[00116] FIGs. 19 and 20 are perspective and cross-sectional views of another example rotary piston-type actuator 1900. Whereas the actuators described previously, e.g., the example actuator 100 of FIG. 1, are generally elongated and cylindrical, the actuator 1900 is comparatively flatter and more disk-shaped.

[00117] Referring to FIG. 19, a perspective view of the example rotary piston-type actuator 1900 is shown. The actuator 1900 includes a rotary

piston assembly 1910 and a pressure chamber assembly 1920. The rotary piston assembly 1910 includes a rotor shaft 1912. A collection of rotor arms 1914 extend radially from the rotor shaft 1912, the distal end of each rotor arm 1914 including a bore 1916 aligned substantially parallel with the axis of the rotor shaft 1912 and sized to accommodate one of a collection of connector pins 1918.

[00118] The rotary piston assembly 1910 of example actuator 1900 includes a pair of rotary pistons 1930 arranged substantially symmetrically opposite each other across the rotor shaft 1912. In the example of the actuator 1900, the rotary pistons 1930 are both oriented in the same rotational direction, e.g., the rotary pistons 1930 cooperatively push in the same rotational direction. In some embodiments, a return force may be provided to rotate the rotary piston assembly 1910 in the direction of the rotary pistons 1930. For example, the rotor shaft 1912 may be coupled to a load that resists the forces provided by the rotary pistons 1930, such as a load under gravitational pull, a load exposed to wind or water resistance, a return spring, or any other appropriate load that can rotate the rotary piston assembly. In some embodiments, the actuator 1900 can include a pressurizable outer housing over the pressure chamber assembly 1920 to provide a back-drive operation, e.g., similar to the function provided by the outer housing 450 in FIG. 4. In some embodiments, the actuator 1900 can be rotationally coupled to an oppositely oriented actuator 1900 that can provide a back-drive operation.

[00119] In some embodiments, the rotary pistons 1930 can be oriented in opposite rotational directions, e.g., the rotary pistons 1930 can oppose each other push in the opposite rotational directions to provide bidirectional motion control. In some embodiments, the actuator 100 can rotate the rotor shaft about 60 degrees total.

[00120] Each of the rotary pistons 1930 of example actuator 1900 includes a piston end 1932 and one or more connector arms 1934. The piston end 1932 is formed to have a generally semi-circular body having a substantially smooth surface. Each of the connector arms 1934 includes a bore 1936 (see FIGs. 21B and 21C) substantially aligned with the axis of the semi-circular body of

the piston end 1932 and sized to accommodate one of the connector pins 1918.

[00121] Each of the rotary pistons 1930 of example actuator 1900 is assembled to the rotor shaft 1912 by aligning the connector arms 1934 with
5 the rotor arms 1914 such that the bores 1916 of the rotor arms 1914 align with the bores 1936. The connector pins 1918 are inserted through the aligned bores to create hinged connections between the pistons 1930 and the rotor shaft 1912. Each connector pin 1916 is slightly longer than the aligned bores. About the circumferential periphery of each end of each connector pin 1916
10 that extends beyond the aligned bores is a circumferential recess (not shown) that can accommodate a retaining fastener (not shown), e.g., a snap ring or spiral ring.

[00122] Referring now to FIG. 20 a cross-sectional view of the example rotary piston-type actuator 1900 is shown. The illustrated example shows the
15 rotary pistons 1930 partly inserted into a corresponding pressure chamber 1960 formed as an arcuate cavity in the pressure chamber assembly 1920.

[00123] Each pressure chamber 1960 of example actuator 1900 includes a seal assembly 1962 about the interior surface of the pressure chamber 1960 at an open end 1964. In some embodiments, the seal assembly 1962 can be a
20 circular or semi-circular sealing geometry retained on all sides in a standard seal groove.

[00124] When the rotary pistons 1930 of example actuator 1900 are inserted through the open ends 1964, each of the seal assemblies 1962 contacts the interior surface of the pressure chamber 1960 and the substantially smooth
25 surface of the piston end 1932 to form a substantially pressure-sealed region within the pressure chamber 1960. Each of the pressure chambers 1960 each include a fluid port (not shown) formed through the pressure chamber assembly 1920, through which pressurized fluid may flow.

[00125] Upon introduction of pressurized fluid, e.g., hydraulic oil, water, air,
30 gas, into the pressure chambers 1960 of example actuator 1900, the pressure differential between the interior of the pressure chambers 1960 and the ambient conditions outside the pressure chambers 1960 causes the piston ends 1932 to be urged outward from the pressure chambers 1960. As the

piston ends 1932 are urged outward, the pistons 1930 urge the rotary piston assembly 1910 to rotate.

[00126] In the illustrated example actuator 1900, each of the rotary pistons 1930 includes a cavity 1966. FIGs. 21A-21C provide additional cross-sectional and perspective views of one of the rotary pistons 1930. Referring to FIG. 21A, a cross-section the rotary piston 1930, taken across a section of the piston end 1932 is shown. The cavity 1966 is formed within the piston end 1932.

Referring to FIG. 21B, the connector arm 1934 and the bore 1936 is shown in perspective. FIG. 21C features a perspective view of the cavity 1966.

[00127] In some embodiments, the cavity 1966 may be omitted. For example, the piston end 1932 may be solid in cross-section. In some embodiments, the cavity 1966 may be formed to reduce the mass of the rotary piston 1930 and the mass of the actuator 1900. For example, the actuator 1900 may be implemented in an aircraft application, where weight may play a role in actuator selection. In some embodiments, the cavity 1966 may reduce wear on seal assemblies, such as the seal assembly 320 of FIG. 3. For example, by reducing the mass of the rotary piston 1930, the amount of force the piston end 1932 exerts upon the corresponding seal assembly may be reduced when the mass of the rotary piston is accelerated, e.g., by gravity or G-forces.

[00128] In some embodiments, the cavity 1966 may be substantially hollow in cross-section, and include one or more structural members, e.g., webs, within the hollow space. For example, structural cross-members may extend across the cavity of a hollow piston to reduce the amount by which the piston may distort, e.g., bowing out, when exposed to a high pressure differential across the seal assembly.

[00129] FIGs. 22 and 23 illustrate a comparison of two example rotor shaft embodiments. FIG. 22 is a perspective view of an example rotary piston-type actuator 2200. In some embodiments, the example actuator 2200 can be the example actuator 1900.

[00130] The example actuator 2200 includes a pressure chamber assembly 2210 and a rotary piston assembly 2220. The rotary piston assembly 2220

includes at least one rotary piston 2222 and one or more rotor arms 2224. The rotor arms 2224 extend radially from a rotor shaft 2230.

[00131] The rotor shaft 2230 of example actuator includes an output section 2232 and an output section 2234 that extend longitudinally from the pressure chamber assembly 2210. The output sections 2232-2234 include a collection of splines 2236 extending radially from the circumferential periphery of the output sections 2232-2234. In some implementations, the output section 2232 and/or 2234 may be inserted into a correspondingly formed splined assembly to rotationally couple the rotor shaft 2230 to other mechanisms. For example, by rotationally coupling the output section 2232 and/or 2234 to an external assembly, the rotation of the rotary piston assembly 2220 may be transferred to urge the rotation of the external assembly.

[00132] FIG. 23 is a perspective view of another example rotary piston-type actuator 2300. The actuator 2300 includes the pressure chamber assembly 2210 and a rotary piston assembly 2320. The rotary piston assembly 2320 includes at least one of the rotary pistons 2222 and one or more of the rotor arms 2224. The rotor arms 2224 extend radially from a rotor shaft 2330.

[00133] The rotor shaft 2330 of example actuator 2300 includes a bore 2332 formed longitudinally along the axis of the rotor shaft 2330. The rotor shaft 2330 includes a collection of splines 2336 extending radially inward from the circumferential periphery of the bore 2332. In some embodiments, a correspondingly formed splined assembly may be inserted into the bore 2332 to rotationally couple the rotor shaft 2330 to other mechanisms.

[00134] FIG. 24 is a perspective view of another example rotary piston 2400. In some embodiments, the rotary piston 2400 can be the rotary piston 250, 260, 414, 712, 812, 822, 1530a, 1530b, 1730a, 1730b, 1930 or 2222.

[00135] The example rotary piston 2400 includes a piston end 2410 and a connector section 2420. The connector section 2420 includes a bore 2430 formed to accommodate a connector pin, e.g., the connector pin 214.

[00136] The piston end 2410 of example actuator 2400 includes an end taper 2440. The end taper 2440 is formed about the periphery of a terminal end 2450 of the piston end 2410. The end taper 2440 is formed at a radially inward angle starting at the outer periphery of the piston end 2410 and ending

at the terminal end 2450. In some implementations, the end taper 2440 can be formed to ease the process of inserting the rotary piston 2400 into a pressure chamber, e.g., the pressure chamber 310.

5 **[00137]** The piston end 2410 of example actuator 2400 is substantially smooth. In some embodiments, the smooth surface of the piston end 2410 can provide a surface that can be contacted by a seal assembly. For example, the seal assembly 320 can contact the smooth surface of the piston end 2410 to form part of a fluidic seal, reducing the need to form a smooth, fluidically sealable surface on the interior walls of the pressure chamber 310.

10 **[00138]** In the illustrated example, the rotary piston 2400 is shown as having a generally solid circular cross-section, whereas the rotary pistons piston 250, 260, 414, 712, 812, 822, 1530a, 1530b, 1730a, 1730b, 1930 or 2222 have been illustrated as having various generally rectangular, elliptical, and other shapes, both solid and hollow, in cross section. In some embodiments, the
15 cross sectional dimensions of the rotary piston 2400, as generally indicated by the arrows 2491 and 2492, can be adapted to any appropriate shape, e.g., square, rectangular, ovoid, elliptical, circular, and other shapes, both solid and hollow, in cross section.. In some embodiments, the arc of the rotary piston 2400, as generally indicated by the angle 2493, can be adapted to any
20 appropriate length. In some embodiments, the radius of the rotary piston 2400, as generally indicated by the line 2494, can be adapted to any appropriate radius. In some embodiments, the piston end 2410 can be substantially solid, substantially hollow, or can include any appropriate hollow formation. In some embodiments, any of the previously mentioned forms of
25 the piston end 2410 can also be used as the piston ends 1220a and/or 1220b of the dual rotary pistons 1216 of FIG. 12.

[00139] FIG. 25 is a flow diagram of an example process 2500 for performing rotary actuation. In some implementations, the process 2500 can be performed by the rotary piston-type actuators 100, 400, 700, 800, 1200,
30 1500, 1700, 1900, 2200, 2300, and/or 2600 which will be discussed in the descriptions of FIGs. 26-28.

[00140] At 2510, a rotary actuator is provided. The rotary actuator of example actuator 2500 includes a first housing defining a first arcuate chamber

including a first cavity, a first fluid port in fluid communication with the first cavity, an open end, and a first seal disposed about an interior surface of the open end, a rotor assembly rotatably journaled in the first housing and including a rotary output shaft and a first rotor arm extending radially outward
5 from the rotary output shaft, an arcuate-shaped first piston disposed in the first housing for reciprocal movement in the first arcuate chamber through the open end. The first seal, the first cavity, and the first piston define a first pressure chamber, and a first connector, coupling a first end of the first piston to the first rotor arm. For example, the actuator 100 includes the components of the
10 pressure chamber assembly 300 and the rotary piston assembly 200 included in the actuation section 120.

[00141] At 2520, a pressurized fluid is applied to the first pressure chamber. For example, pressurized fluid can be flowed through the fluid port 320 into the pressure chamber 310.

15 **[00142]** At 2530, the first piston is urged partially outward from the first pressure chamber to urge rotation of the rotary output shaft in a first direction. For example, a volume of pressurized fluid flowed into the pressure chamber 310 will displace a similar volume of the rotary piston 260, causing the rotary piston 260 to be partly urged out of the pressure cavity 310, which in turn will
20 cause the rotor shaft 210 to rotate clockwise.

[00143] At 2540, the rotary output shaft is rotated in a second direction opposite that of the first direction. For example, the rotor shaft 210 can be rotated counter-clockwise by an external force, such as another mechanism, a torque-providing load, a return spring, or any other appropriate source of
25 rotational torque.

[00144] At 2550, the first piston is urged partially into the first pressure chamber to urge pressurized fluid out the first fluid port. For example, the rotary piston 260 can be pushed into the pressure chamber 310, and the volume of the piston end 252 extending into the pressure chamber 310 will
30 displace a similar volume of fluid, causing it to flow out the fluid port 312.

[00145] In some embodiments, the example process 2500 can be used to provide substantially constant power over stroke to a connected mechanism.

For example, as the actuator 100 rotates, there may be substantially little position-dependent variation in the torque delivered to a connected load.

[00146] In some embodiments, the first housing further defines a second arcuate chamber comprising a second cavity, a second fluid port in fluid communication with the second cavity, and a second seal disposed about an interior surface of the open end, the rotor assembly also includes a second rotor arm, the rotary actuator also includes an arcuate-shaped second piston disposed in said housing for reciprocal movement in the second arcuate chamber, wherein the second seal, the second cavity, and the second piston define a second pressure chamber, and a second connector coupling a first end of the second piston to the second rotor arm. For example, the actuator 100 includes the components of the pressure chamber assembly 300 and the rotary piston assembly 200 included in the actuation section 110.

[00147] In some embodiments, the second piston can be oriented in the same rotational direction as the first piston. For example, the two pistons 260 are oriented to operate cooperatively in the same rotational direction. In some embodiments, the second piston can be oriented in the opposite rotational direction as the first piston. For example, the rotary pistons 250 are oriented to operate in the opposite rotational direction relative to the rotary pistons 260.

[00148] In some embodiments, the actuator can include a second housing and disposed about the first housing and having a second fluid port, wherein the first housing, the second housing, the seal, and the first piston define a second pressure chamber. For example, the actuator 400 includes the outer housing 450 that substantially surrounds the pressure chamber assembly 420. Pressurized fluid in the bore 452 is separated from fluid in the pressure chambers 422 by the seals 426.

[00149] In some implementations, rotating the rotary output shaft in a second direction opposite that of the first direction can include applying pressurized fluid to the second pressure chamber, and urging the second piston partially outward from the second pressure chamber to urge rotation of the rotary output shaft in a second direction opposite from the first direction. For example, pressurized fluid can be applied to the pressure chambers 310 of the

first actuation section 110 to urge the rotary pistons 260 outward, causing the rotor shaft 210 to rotate counter-clockwise.

[00150] In some implementations, rotating the rotary output shaft in a second direction opposite that of the first direction can include applying pressurized fluid to the second pressure chamber, and urging the first piston partially into the first pressure chamber to urge rotation of the rotary output shaft in a second direction opposite from the first direction. For example, pressurized fluid can be flowed into the bore 452 at a pressure higher than that of fluid in the pressure chambers 422, causing the rotary pistons 414 to move into the pressure chambers 422 and cause the rotor shaft 412 to rotate counter-clockwise.

[00151] In some implementations, rotation of the rotary output shaft can urge rotation of the housing. For example, the rotary output shaft 412 can be held rotationally stationary and the housing 450 can be allowed to rotate, and application of pressurized fluid in the pressure chambers 422 can urge the rotary pistons 414 out of the pressure chambers 422, causing the housing 450 to rotate about the rotary output shaft 412.

[00152] FIGs. 26-28 show various views of the components of another example rotary piston-type actuator 2600. In general, the actuator 2600 is similar to the example actuator 100 of FIG. 1, except for the configuration of the seal assemblies. Whereas the seal assembly 320 in the example actuator 100 remains substantially stationary relative to the pressure chamber 310 and is in sliding contact with the surface of the rotary piston 250, in the example actuator 2600, the seal configuration is comparatively reversed as will be described below.

[00153] Referring to FIG. 26, a perspective view of the example rotary piston-type actuator 2600 is shown. The actuator 2600 includes a rotary piston assembly 2700 and a pressure chamber assembly 2602. The actuator 2600 includes a first actuation section 2610 and a second actuation section 2620. In the example of actuator 2600, the first actuation section 2610 is configured to rotate the rotary piston assembly 2700 in a first direction, e.g., counter-clockwise, and the second actuation section 2620 is configured to

rotate the rotary piston assembly 2700 in a second direction substantially opposite the first direction, e.g., clockwise.

[00154] Referring now to FIG. 27, a perspective view of the example rotary piston assembly 2700 is shown apart from the pressure chamber assembly 2602. The rotary piston assembly 2700 includes a rotor shaft 2710. A plurality of rotor arms 2712 extend radially from the rotor shaft 2710, the distal end of each rotor arm 2712 including a bore (not shown) substantially aligned with the axis of the rotor shaft 2710 and sized to accommodate one of a collection of connector pins 2714.

[00155] As shown in FIG. 27, the first actuation section 2710 of example rotary piston assembly 2700 includes a pair of rotary pistons 2750, and the second actuation section 2720 includes a pair of rotary pistons 2760. While the example actuator 2600 includes two pairs of the rotary pistons 2750, 2760, other embodiments can include greater and/or lesser numbers of cooperative and opposing rotary pistons.

[00156] In the example rotary piston assembly shown in FIG. 27, each of the rotary pistons 2750, 2760 includes a piston end 2752 and one or more connector arms 2754. The piston end 252 is formed to have a generally semi-circular body having a substantially smooth surface. Each of the connector arms 2754 includes a bore 2756 substantially aligned with the axis of the semi-circular body of the piston end 2752 and sized to accommodate one of the connector pins 2714.

[00157] In some implementations, each of the rotary pistons 2750, 2760 includes a seal assembly 2780 disposed about the outer periphery of the piston ends 2752. In some implementations, the seal assembly 2780 can be a circular or semi-circular sealing geometry retained on all sides in a standard seal groove. In some implementations, commercially available reciprocating piston or cylinder type seals can be used. For example, commercially available seal types that may already be in use for linear hydraulic actuators flying on current aircraft may demonstrate sufficient capability for linear load and position holding applications. In some implementations, the sealing complexity of the actuator 2600 may be reduced by using a standard, e.g., commercially available, semi-circular, unidirectional seal designs generally used in linear

hydraulic actuators. In some embodiments, the seal assembly 2780 can be a one-piece seal.

[00158] FIG. 28 is a perspective cross-sectional view of the example rotary piston-type actuator 2600. The illustrated example shows the rotary pistons 2760 inserted into a corresponding pressure chamber 2810 formed as an arcuate cavity in the pressure chamber assembly 2602. The rotary pistons 2750 are also inserted into corresponding pressure chambers 2810, not visible in this view.

[00159] In the example actuator 2600, when the rotary pistons 2750, 2760 are each inserted through an open end 2830 of each pressure chamber 2810, each seal assembly 2780 contacts the outer periphery of the piston end 2760 and the substantially smooth interior surface of the pressure chamber 2810 to form a substantially pressure-sealed region within the pressure chamber 2810.

[00160] In some embodiments, the seal 2780 can act as a bearing. For example, the seal 2780 may provide support for the piston 2750, 2760 as it moves in and out of the pressure chamber 310.

[00161] FIGs. 29A-29E are various views of another example rotary piston-type actuator 2900 with a central actuation assembly 2960. For a brief description of each drawing see the brief description of each of these drawings included at the beginning of the Description of the Drawings section of this document.

[00162] In general, the example rotary piston-type actuator 2900 is substantially similar to the example rotary piston-type actuator 1200 of FIGs.12-14, where the example rotary piston-type actuator 2900 also includes a central actuation assembly 2960 and a central mounting assembly 2980. Although the example rotary piston-type actuator 2900 is illustrated and described as modification of the example rotary piston-type actuator 1200, in some embodiments the example rotary piston-type actuator 2900 can implement features of any of the example rotary piston-type actuators 100, 400, 700, 800, 1200, 1500, 1700, 1900, 2200, 2300, and/or 2600 in a design that also implements the central actuation assembly 2960 and/or the central mounting assembly 2980.

[00163] The actuator 2900 includes a rotary actuator assembly 2910, a first actuation section 2901 and a second actuation section 2902. The rotary piston assembly 2910 includes a rotor shaft 2912, a collection of rotor arms 2914, and the collection of dual rotary pistons, e.g., the dual rotary pistons 1216 of
5 FIGs. 12-14.

[00164] The first actuation section 2901 of example actuator 2900 includes a first pressure chamber assembly 2950a, and the second actuation section 2902 includes a second pressure chamber assembly 2950b. The first pressure chamber assembly 2950a includes a collection of pressure
10 chambers, e.g., the pressure chambers 1252a of FIGs. 12-14, formed as arcuate cavities in the first pressure chamber assembly 2950a. The second pressure chamber assembly 2950b includes a collection of pressure chambers, e.g., the pressure chambers 1252b of FIGs. 12-14, formed as arcuate cavities in the second pressure chamber assembly 2950b. A
15 semicircular bore 2953 in the housing accommodates the rotor shaft 2912.

[00165] The central mounting assembly 2980 is formed as a radially projected portion 2981 of a housing of the second pressure chamber assembly 2950b. The central mounting assembly 2980 provides a mounting point for removably affixing the example rotary piston-type actuator 2900 to an external
20 surface, e.g., an aircraft frame. A collection of holes 2982 formed in the radially projected section 2981 accommodate the insertion of a collection of fasteners 2984, e.g., bolts, to removably affix the central mounting assembly 2980 to an external mounting feature 2990, e.g., a mounting point (bracket) on an aircraft frame.

[00166] The central actuation assembly 2960 includes a radial recess 2961 formed in a portion of an external surface of a housing of the first and the second actuation sections 2901, 2902 at a midpoint along a longitudinal axis AA to the example rotary piston-type actuator 2900. An external mounting bracket 2970 that may be adapted for attachment to an external mounting
30 feature on a member to be actuated, (e.g., aircraft flight control surfaces) is connected to an actuation arm 2962. The actuation arm 2962 extends through the recess 2961 and is removably attached to a central mount point 2964

formed in an external surface at a midpoint of the longitudinal axis of the rotor shaft 2912.

[00167] Referring more specifically to FIGs. 29D and 29E now, the example rotary piston-type actuator 2900 is shown in cutaway end and perspective views taken through a midpoint of the central actuation assembly 2960 and the central mounting assembly 2980 at the recess 2961. The actuation arm 2962 extends into the recess 2961 to contact the central mount point 2964 of the rotor shaft 2912. The actuation arm 2962 is removably connected to the central mount point 2964 by a fastener 2966, e.g., bolt, that is passed through a pair of holes 2968 formed in the actuation arm 2962 and a hole 2965 formed through the central mount point 2964. A collection of holes 2969 are formed in a radially outward end of the actuation arm 2962. A collection of fasteners 2972, e.g., bolts, are passed through the holes 2969 and corresponding holes (not shown) formed in an external mounting feature (bracket) 2970. As mentioned above, the central actuation assembly 2960 connects the example rotary piston actuator 2900 to the external mounting feature 2970 to transfer rotational motion of the rotor assembly 2910 to equipment to be moved (actuated), e.g., aircraft flight control surfaces.

[00168] In some embodiments, one of the central actuation assembly 2960 or the central mounting assembly 2980 can be used in combination with features of any of the example rotary piston-type actuators 100, 400, 700, 800, 1200, 1500, 1700, 1900, 2200, 2300, and/or 2600. For example, the example rotary piston-type actuator 2900 may be mounted to a stationary surface through the central mounting assembly 2980, and provide actuation at one or both ends of the rotor shaft assembly 2910. In another example, the example rotary piston assembly 2900 may be mounted to a stationary surface through non-central mounting points, and provide actuation at the central actuation assembly 2960.

[00169] FIGs. 30A-30E are various views of an example rotary actuator 3000 with a central actuation assembly 3060. For a brief description of each drawing see the brief description of each of these drawings included at the beginning of the Description of the Drawings section of this document.

[00170] In general, the example rotary actuator 3000 is substantially similar to the rotary piston-type actuator 2900 of FIGs. 29A-29E, where the example rotary actuator 3000 also includes a central actuation assembly 3060 and a central mounting assembly 3080. In some embodiments, the example rotary actuator 3000 can be a modification of the example rotary piston-type actuator 2900 in which rotational action can be performed by a mechanism other than a rotary piston-type actuator. For example, the example rotary actuator 3000 can include a rotary vane type actuator, a rotary fluid type actuator, an electromechanical actuator, a linear-to-rotary motion actuator, or combinations of these or any other appropriate rotary actuator. Although the example rotary actuator 3000 is illustrated and described as modification of the example rotary piston-type actuator 2900, in some embodiments the example rotary actuator 3000 can implement features of any of the example rotary piston-type actuators 100, 400, 700, 800, 1200, 1500, 1700, 1900, 2200, 2300, 2600 and/or 2900 in a design that also implements the central actuation assembly 3060 and/or the central mounting assembly 3080.

[00171] The actuator 3000 includes a rotary actuator section 3010a and a rotary actuator section 3010b. In some embodiments, the rotary actuator sections 3010a and 3010b can be rotary vane type actuators, a rotary fluid type actuators, electromechanical actuators, a linear-to-rotary motion actuators, or combinations of these or any other appropriate rotary actuators. The rotary actuator section 3010a includes a housing 3050a, and the rotary actuator section 3010b includes a housing 3050b. A rotor shaft 3012a runs along the longitudinal axis of the rotary actuator section 3010a, and a rotor shaft 3012b runs along the longitudinal axis of the rotary actuator section 3010b.

[00172] The central mounting assembly 3080 is formed as a radially projected portion 3081 of the housings 3050a and 3050b. The central mounting assembly 3080 provides a mounting point for removably affixing the example rotary actuator 3000 to an external surface or an external structural member, e.g., an aircraft frame, an aircraft control surface. A collection of holes 3082 formed in the radially projected section 3081 accommodate the insertion of a collection of fasteners (not shown), e.g., bolts, to removably affix

the central mounting assembly 3080 to an external mounting feature, e.g., the external mounting feature 2090 of FIG. 29, a mounting point (bracket) on an aircraft frame or control surface.

[00173] The central actuation assembly 3060 includes a radial recess 3061 formed in a portion of an external surfaces of the housings 3050a, 3050b at a midpoint along a longitudinal axis AA to the example rotary actuator 3000. In some implementations, an external mounting bracket, such as the external mounting bracket 2970, may be adapted for attachment to an external mounting feature of a structural member or a member to be actuated, (e.g., aircraft flight control surfaces) can be connected to an actuation arm 3062. An actuation arm, such as the actuation arm 2962, can extend through the recess 3061 and can be removably attached to a central mount point 3064 formed in an external surface at a midpoint of the longitudinal axis of the rotor shafts 3012a and 3012b.

[00174] Referring more specifically to FIGs. 30D and 30E now, the example rotary piston-type actuator 3000 is shown in end and cutaway perspective views taken though a midpoint of the central actuation assembly 3060 and the central mounting assembly 3080 at the recess 3061. The actuation arm (not shown) can extend into the recess 3061 to contact the central mount point 3064 of the rotor shafts 3012a, 3012b. The actuation arm can be removably connected to the central mount point 3064 by a fastener, e.g., bolt, that can be passed through a pair of holes (e.g. the holes 2968 formed in the actuation arm 2962) and a hole 3065 formed through the central mount point 3064. Similarly to as was discussed in the description of the rotary piston-type actuator 2900 and the central actuation assembly 2960, the central actuation assembly 3060 connects the example rotary actuator 3000 to an external mounting feature or structural member to impart rotational motion of the actuator sections 3010a, 3010b to equipment to be moved (actuated), e.g., aircraft flight control surfaces, relative to structural members, e.g., aircraft frames.

[00175] In some embodiments, one of the central actuation assembly 3060 or the central mounting assembly 3080 can be used in combination with features of any of the example rotary piston-type actuators 100, 400, 700, 800,

1200, 1500, 1700, 1900, 2200, 2300, 2600 and/or 2900. For example, the example rotary actuator 3000 may be mounted to a stationary surface through the central mounting assembly 3080, and provide actuation at one or both ends of the rotor shafts 3012a, 3012b. In another example, the example rotary
5 actuator 3000 may be mounted to a stationary surface through non-central mounting points, and provide actuation at the central actuation assembly 3060. In another example, the rotary actuator 3000 may be mounted to a stationary surface through the central mount point 3064, and provide actuation at the central mounting assembly 3080.

10 **[00176]** FIGs. 31A-31E are various views of an example rotary actuator 3100 with a central actuation assembly 3160. For a brief description of each drawing see the brief description of each of these drawings included at the beginning of the Description of the Drawings section of this document.

[00177] In general, the example rotary actuator 3100 is substantially similar
15 to the rotary actuator 3000 of FIGs. 30A-30E, where the example rotary actuator 3100 also includes a central actuation assembly 3160 and a central mounting assembly 3180. In some embodiments, the example rotary actuator 3100 can be a modification of the example rotary piston-type actuator 3000 in which rotational action can be performed by a mechanism other than a rotary
20 fluid actuator. The example rotary actuator 3100 is an an electromechanical actuator. Although the example rotary actuator 3100 is illustrated and described as modification of the example rotary actuator 3000, in some embodiments the example rotary actuator 3100 can implement features of any of the example rotary piston-type actuators 100, 400, 700, 800, 1200, 1500,
25 1700, 1900, 2200, 2300, 2600 and/or 2900 and/or the rotary actuator 3000 in a design that also implements the central actuation assembly 3160 and/or the central mounting assembly 3180.

[00178] The actuator 3100 includes a rotary actuator section 3110a and a rotary actuator section 3110b. In some embodiments, the rotary actuator
30 sections 3110a and 3110b can be electromechanical actuators. The rotary actuator section 3110a includes a housing 3150a, and the rotary actuator section 3110b includes a housing 3150b. A rotor shaft 3112a runs along the

longitudinal axis of the rotary actuator section 3110a, and a rotor shaft 3112b runs along the longitudinal axis of the rotary actuator section 3110b.

[00179] The central mounting assembly 3180 is formed as a radially projected portion 3181 of the housings 3150a and 3150b. The central mounting assembly 3180 provides a mounting point for removably affixing the example rotary actuator 3100 to an external surface or an external structural member, e.g., an aircraft frame, an aircraft control surface. A collection of holes 3182 formed in the radially projected section 3181 accommodate the insertion of a collection of fasteners (not shown), e.g., bolts, to removably affix the central mounting assembly 3180 to an external mounting feature, e.g., the external mounting feature 2090 of FIG. 29, a mounting point (bracket) on an aircraft frame or control surface.

[00180] The central actuation assembly 3160 includes a radial recess 3161 formed in a portion of an external surfaces of the housings 3150a, 3150b at a midpoint along a longitudinal axis AA to the example rotary actuator 3100. In some implementations, an external mounting bracket, such as the external mounting bracket 2970, may be adapted for attachment to an external mounting feature of a structural member or a member to be actuated, (e.g., aircraft flight control surfaces) can be connected to an actuation arm 3162. An actuation arm, such as the actuation arm 2962, can extend through the recess 3161 and can be removably attached to a central mount point 3164 formed in an external surface at a midpoint of the longitudinal axis of the rotor shafts 3112a and 3112b.

[00181] Referring more specifically to FIGs. 31D and 31E now, the example rotary piston-type actuator 3100 is shown in end and cutaway perspective views taken through a midpoint of the central actuation assembly 3160 and the central mounting assembly 3080 at the recess 3161. The actuation arm (not shown) can extend into the recess 3161 to contact the central mount point 3164 of the rotor shafts 3112a, 3112b. The actuation arm can be removably connected to the central mount point 3164 by a fastener, e.g., bolt, that can be passed through a pair of holes (e.g. the holes 2968 formed in the actuation arm 2962) and a hole 3165 formed through the central mount point 3164. Similarly to as was discussed in the description of the rotary piston-type

actuator 2900 and the central actuation assembly 2960, the central actuation assembly 3160 connects the example rotary actuator 3100 to an external mounting feature or structural member to impart rotational motion of the actuator sections 3110a, 3110b to equipment to be moved (actuated), e.g., aircraft flight control surfaces, relative to structural members, e.g., aircraft frames.

[00182] In some embodiments, one of the central actuation assembly 3160 or the central mounting assembly 3180 can be used in combination with features of any of the example rotary piston-type actuators 100, 400, 700, 800, 1200, 1500, 1700, 1900, 2200, 2300, 2600 and/or 2900 and/or the rotary actuator 3000. For example, the example rotary actuator 3100 may be mounted to a stationary surface through the central mounting assembly 3180, and provide actuation at one or both ends of the rotor shafts 3112a, 3112b. In another example, the example rotary actuator 3100 may be mounted to a stationary surface through non-central mounting points, and provide actuation at the central actuation assembly 3160. In another example, the rotary actuator 3100 may be mounted to a stationary surface through the central mount point 3164, and provide actuation at the central mounting assembly 3180.

[00183] FIG. 32 is an exploded perspective view of another example pressure chamber assembly 3200. In some embodiments, features of the pressure chamber assembly 3200 can be used with any of the actuators 400, 800, 1200, 1500, 1750, 1900, 2200, 2300, and 2600. The pressure chamber assembly 3200 includes a housing 3210, a modular piston housing 3250a, and a modular piston housing 3250b. The housing 3210 includes a central longitudinal cavity 3212. The central longitudinal cavity 3212 is formed to accommodate a rotor shaft (not shown) such as the rotor shaft 210 of the rotary piston assembly 200 of FIG. 2.

[00184] The modular piston housing 3250a of example pressure chamber assembly 3200 is an arcuate-shaped assembly that includes a collection of pressure chambers 3252a formed as arcuate cavities in the modular piston housing 3250a. Similarly, the modular piston housing 3250b is also an arcuate-shaped assembly that includes a collection of pressure chambers

3252b formed as arcuate cavities in the modular piston housing 3250b. In the illustrated example, the modular piston housing 3250b mirrors the arcuate shape of the modular piston housing 3250a. The pressure chambers 3252a, 3252b are formed to accommodate rotary pistons (not shown) such as rotary
5 pistons 250. In some implementations, the modular piston housings 3250a, 3250b can be formed as unitary piston housings. For example, the modular piston housings 3250a, 3250b may each be machined, extruded, or otherwise formed without forming seams within the pressure chambers 3251a, 3252b.

[00185] In the assembled form of the example pressure chamber assembly
10 3200, the modular piston housings 3250a, 3250b are removably affixed to the housing 3210. In some embodiments, the pressure chamber assembly 3200 can include radial apertures into which the modular piston housings 3250a, 3250b can be inserted. In some embodiments, the pressure chamber assembly 3200 can include longitudinal apertures into which the modular
15 piston housings 3250a, 3250b can be inserted.

[00186] The modular piston housings 3250a, 3250b of example pressure chamber assembly 3200 include a collection of bores 3254. In the assembled form of the pressure chamber assembly 3200 the bores 3254 align with a collection of bores 3256 formed in the housing 3210, a collection of fasteners
20 (not shown), e.g., bolts or screws, are passed through the bores 3256 and into the bores 3254 to removably affix the modular piston housings 3250a, 3250b to the housing 3210.

[00187] In some embodiments, modular piston housings 3250a, 3250b can include a seal assembly about the interior surface of the pressure chambers
25 3252a, 3252b. In some embodiments, the seal assembly can be a circular or semi-circular sealing geometry retained on all sides in a standard seal groove. In some embodiments, commercially available reciprocating piston or cylinder type seals can be used. For example, commercially available seal types that may already be in use for linear hydraulic actuators flying on current aircraft
30 may demonstrate sufficient capability for linear load and position holding applications. In some embodiments, the sealing complexity of the example pressure chamber assembly 3200 may be reduced by using a standard, e.g., commercially available, semi-circular, unidirectional seal design generally used

in linear hydraulic actuators. In some embodiments, the seal assemblies can be a one-piece seal. In some embodiments of the modular piston housings 3250a, 3250b, the seal assemblies may be included as part of the rotary pistons. In some embodiments, the modular piston housings 3250a, 3250b
5 may include a wear member between the pistons and the pressure chambers 3252a, 3252b.

[00188] Each of the pressure chambers 3252a, 3252b of example pressure chamber assembly 3200 may include a fluid port (not shown) formed through the modular piston housings 3250a, 3250b, through which pressurized fluid
10 may flow. Upon introduction of pressurized fluid (e.g., hydraulic oil, water, air, gas) into the pressure chambers 3252a, 3252b, the pressure differential between the interior of the pressure chambers 3252a, 3252b and the ambient conditions outside the pressure chambers 3252a, 3252b can cause ends of the pistons to be urged outward from the pressure chambers 3252a, 3252b.
15 As the piston ends are urged outward, the pistons urge a rotary piston assembly, such as the rotary piston assembly 200, to rotate.

[00189] In some embodiments, the modular piston housings 3250a, 3250b may include the central longitudinal cavity 3212 and other features of the housing 3210. In some embodiments, the modular piston housings 3250a,
20 3250b may be removably affixed to each other. For example, the modular piston housings 3250a, 3250b may be bolted, screwed, clamped, welded, pinned, or otherwise directly or indirectly retained relative to each other such that the assembled combination provides the features of the housing 3210, eliminating the need for the housing 3210.

[00190] FIGs. 33A-33C are exploded and assembled perspective views of
25 another example rotary piston assembly 3300. In some embodiments, features of the rotary piston assembly 3300 can be used with any of the rotary piston assemblies 200, 700, 1100, 1501, 1701, and 2700, and/or with any of the actuators 400, 800, 1200, 1500, 1750, 1900, 2200, 2300, 2600, 2900, and
30 3000. The rotary piston assembly 3300 includes a rotor shaft 3310. A plurality of rotor arms 3312 extend radially from the rotor shaft 3310, the distal end of each rotor arm 3312 including a bore (not shown) substantially aligned with the

axis of the rotor shaft 3310 and sized to accommodate one of a collection of connector pins 3314.

[00191] The example rotary piston assembly 3300 includes a pair of rotary pistons 3350. While the example rotary piston assembly 3300 includes two of the rotary pistons 3350, other embodiments can include greater and/or lesser numbers of cooperative and opposing rotary pistons. Each of the rotary pistons 3350 includes a piston end 3352 and one or more connector arms 3354. The piston end 3352 is formed to have a generally semi-circular body having a substantially smooth surface. Each of the connector arms 3354 includes a bore 3356 substantially aligned with the axis of the semi-circular body of the piston end 3352 and sized to accommodate one of the connector pins 3314.

[00192] Each of the rotary pistons 3350 of the example rotary piston assembly 3300 may be assembled to the rotor shaft 3310 by aligning the connector arms 3354 with the rotor arms 3312 such that the bores (not shown) of the rotor arms 3312 align with the bores 3365. The connector pins 3314 may then be inserted through the aligned bores to create connections between the pistons 3350 and the rotor shaft 3310. As shown, each connector pin 3314 is slightly longer than the aligned bores. In the example assembly, about the circumferential periphery of each end of each connector pin 3314 that extends beyond the aligned bores is a circumferential recess (not shown) that can accommodate a retaining fastener (not shown), e.g., a snap ring or spiral ring.

[00193] The connections between the connector arms 3354 with the rotor arms 3312, unlike embodiments such as the rotary piston assembly 200, are not hinged. The connector arms 3312 include retainer elements 3380, and the rotor arms 3312 include retainer elements 3382. When the assembly 3300 is in its assembled form, the retainer elements 3380, 3382 are intermeshed relative to the rotary motion of the pistons 3350 and the rotor shaft 3310. In some embodiments, the retainer elements 3380, 3382 can be formed with radial geometries that prevent rotation of the rotary pistons 3350 away from the radius of curvature of the rotary pistons 3350.

[00194] In the exemplary embodiment, contact among the retainer elements 3380, 3382 permits rotary movement to be transmitted between the rotor shaft

3310 and the rotary pistons 3350. Movement of the pistons 3350 urges motion of the rotor arms 3312 and the rotor shaft 3310 through contact among the retainer elements 3380, 3382. Likewise, movement of the rotor shaft 3310 and the rotor arms 3312 urges motion of the pistons 3350 through contact among
5 the retainer elements 3380, 3382. In some embodiments, the retainer elements 3380, 3382 can be connected by one or more fasteners that prevent rotation of the rotary pistons 3350 away from the radius of curvature of the rotary pistons 3350. For example, the retainer elements 3380, 3382 can be connected by bolts, screws, clamps, welds, adhesives, or any other
10 appropriate form of connector or fastener.

[00195] In the example rotary piston assembly 3300, contact among the retainer elements 3380, 3382 permits rotary movement to be transmitted between the rotor shaft 3310 and the rotary pistons 3350 even if the connector pin 3314 becomes broken or is missing. In some embodiments, the connector
15 pin 3314 may be longitudinally constrained by a piston housing (not shown). For example, the connector pin 3314 may break at some point along its length, but the housing may be formed such that the ends of the connector pin 3314 may not have sufficient room to permit a broken section of the connector pin 3314 to move far enough longitudinally to become disengaged from the bores
20 3356. In some embodiments such as this, the retainer elements 3380, 3382 and/or the housing can provide a fail-safe construction that can prevent broken pieces of the connector pin 3314 from becoming dislodged from their normal locations, which can present a risk of if such broken pieces were to become jammed within components of a rotary actuator in which the rotary piston
25 assembly 3300 may be used.

[00196] In some embodiments, the connector pin 3314 and the bores 3356 and the bores (not shown) of the rotor arms 3312 can be formed with cross-sectional geometries that prevent rotation of the connector pin 3314 within the bores 3356 and the bores (not shown) of the rotor arms 3312 around the
30 longitudinal axis of the connector pin 3314. For example, the connector pin 3314 can be a "locking pin" formed with a square, rectangular, triangular, hex, star, oval, or any other appropriate non-circular cross-section, and the bores 3356 and the bores (not shown) of the rotor arms 3312 are formed with

corresponding cross-sections, such that the connector pin 3314 can be inserted when the bores are aligned and the pistons 3350 are substantially prevented from rotating about the axis of the connector pin 3314 when the connector pin 3314 is inserted within the bores.

5 **[00197]** In some embodiments, the retainer elements 3380, 3382 and/or the “locking pin” embodiment of the connector pin 3314 can affect the performance of the rotary piston assembly 3300. For example, embodiments of the rotary piston assembly 3300 implementing the retainer elements 3380, 3382 and/or the “locking pin” embodiment of the connector pin 3314, can reduce or prevent
10 relative movement between the pistons 3350 and the rotor arms 3312 as the rotary piston assembly 3300 moves within a rotary piston actuator, which can provide substantially constant torque over a relatively full range of motion of the assembly 3300.

[00198] FIGs. 34A and 34B are perspective views of another example rotary
15 piston 3400. In some embodiments, the rotary piston 3400 can be the rotary piston 3350 of FIGs. 33A-33C. In some embodiments, features of the rotary piston 3400 can be used with any of the rotary piston assemblies 200, 700, 1100, 1501, 1701, and 2700, and/or with any of the actuators 400, 800, 1200, 1500, 1750, 1900, 2200, 2300, 2600, 2900, 3000, 3200 and 3300.

20 **[00199]** As shown in the example rotary piston of FIGs. 34A-34B, the rotary piston 3400 includes a piston end 3432 and one or more connector arms 3434. The piston end 3432 is formed to have a generally elliptical body having a substantially smooth surface. Each of the connector arms 3434 includes a bore 3436a and a bore 3436b substantially aligned with the axis of the elliptical
25 body of the piston end 3432 and sized to accommodate a connector pin such as one of the connector pins 3314. Other embodiments may include more than two bores in a rotary piston. In other embodiments, the piston end 3432 is formed to have a generally rectangular body, or a body having any other appropriate cross-section.

30 **[00200]** In some embodiments, the “multiple pin” embodiment of the rotary piston 3400 can affect the performance of a rotary piston assembly. For example, embodiments of rotary piston assemblies implementing the rotary piston 3400, two locking pins, and a correspondingly formed rotor arm can

reduce or prevent relative movement between the piston 3400 and the rotor arms as the rotary piston assembly moves within a rotary piston actuator, which can provide substantially constant torque over a relatively full range of motion of the assembly.

5 **[00201]** In some embodiments, one or more of the bores 3436a, 3436b can be formed with cross-sectional geometries that prevent rotation of a connector pin, such as the connector pin 3314, within the bores 3436a, 3436b around the longitudinal axis of the connector pin. For example, one or more of the bores 3436a, 3436b can be formed with square, rectangular, triangular, hex, star,
10 oval, or any other appropriate non-circular cross-sections, such that correspondingly configured connector pins can be inserted to substantially prevent the rotary piston 3400 from rotating about the axes of the bores 3436a, 3436b when the connector pins are inserted within the bores 3436a, 3436b.

[00202] FIG. 35A is a perspective view of another example pressure
15 chamber assembly 3500. FIG. 35B is a perspective partial cutaway view of the example pressure chamber assembly 3500. FIG. 35C is a perspective exploded view of the example pressure chamber assembly 3500. In some embodiments, features of the pressure chamber assembly 3500 can be used with any of the rotary piston assemblies 200, 700, 1100, 1501, 1701, and
20 2700, the rotary piston 3400, and/or with any of the actuators 400, 800, 1200, 1500, 1750, 1900, 2200, 2300, 2600, 2900, 3000, 3200 and 3300. As shown in FIG. 35C, the pressure chamber assembly 3500 includes a piston housing 3550, a modular housing 3510a, and a modular housing 3510b. The modular housing 3510a includes an arcuate central recess 3512a, and the modular
25 housing 3510b includes an arcuate central recess 3512b. In their assembled form, the arcuate central recesses 3512a and 3512b accommodate the piston housing 3550.

[00203] As shown in FIG. 35C, the piston housing 3550 is formed to accommodate a rotary piston 3514 in a cavity 3558. The piston housing 3550
30 includes a collar 3552. The collar 3552 is formed to hold a seal 3554 in sealing contact with the rotary piston 3514. In some embodiments, the rotary piston can be any of the rotary pistons 260, 414, 712, 812, 822, 1216, 1520a, 1520b, 1720, 1930, 2222, 2400, 2754, 3350, and 3400. In some

implementations, the pressure chamber 3550 can be formed as a unitary piston housing. For example, pressure chamber 3550 may be machined, extruded, hydro formed, or otherwise formed without forming seams within the pressure chambers 3550.

5 **[00204]** The example rotary piston 3514 includes a bore 3556. In some embodiments, the bore 3556 can be formed with a cross-sectional geometry that prevents rotation of a connector pin, such as the connector pin 3314 of FIGs. 33A-33C, within the bore 3556 and the bores (not shown) of a rotor arm, such as the rotor arms 3312 around the longitudinal axis of the connector pin.
10 For example, the bore 3556 can be formed to accommodate a “locking pin” formed with a square, rectangular, triangular, hex, star, oval, or any other appropriate non-circular cross-section, such that the connector pin can be inserted through the bore 3556 and are substantially prevented from rotating about the axis of the bore 3556 when the connector pin is inserted within the
15 bore 3556.

[00205] In some embodiments, the rotary piston 3514 can include retainer elements. For example, the rotary piston 3514 can include the retainer elements 3380 (for example, as shown in FIGS 33A-C) that can intermesh with the retainer elements 3382 to prevent rotation of the rotary piston 3550 away
20 from the radius of curvature of the rotary pistons 3550.

[00206] FIG. 36 is a perspective view of an example piston housing assembly 3600. The assembly 3600 includes a piston housing 3650a and a piston housing 3650b. The piston housings 3650a-3650b each includes a cavity 3658. In some embodiments, the piston housings 3650a-3650b can be
25 used in place or in addition to the piston housing 3550 of the example pressure chamber assembly 3500 of FIGs. 35A-35C. For example, the piston housings 3650a-3650b can be enclosed by modular housings such as the modular housings 3510a and 3510b.

[00207] The assembly 3600 includes a collection of fluid ports 3652a and
30 3652b. The fluid ports 3652a-3652b are in fluid communication with the cavities 3658 and or fluid supply lines (not shown). In some embodiments, the fluid ports 3652 can flow fluid among the piston housings 3650a-3650b. For example, fluid may be applied to pressurize the piston housings 3650a, and

the fluid will flow through the fluid port 3652a to pressurize the piston housings 3650b as well. In some embodiments, any appropriate number of piston housings, such as the piston housings 3650a-3650b, and fluid ports, such as the fluid ports 3652, can be assembled in an alternating daisy-chain
5 arrangement to form the assembly 3600.

[00208] Although a few implementations have been described in detail above, other modifications are possible. For example, the logic flows depicted in the figures do not require the particular order shown, or sequential order, to achieve desirable results. In addition, other steps may be provided, or steps
10 may be eliminated, from the described flows, and other components may be added to, or removed from, the described systems. Accordingly, other implementations are within the scope of the following claims.

WHAT IS CLAIMED IS:

1. A rotary actuator comprising:
 - a first piston housing assembly comprising a first cavity, a first fluid port
5 in fluid communication with the first cavity, and a first open end;
 - a second piston housing assembly comprising a second cavity, a second fluid port in fluid communication with the second cavity, and a second open end;
 - a rotor assembly rotatably journaled in said first piston housing
10 assembly and said second piston housing assembly, and comprising:
 - a rotary output shaft;
 - a first rotor arm extending radially outward from the rotary output shaft to a first distal end;
 - a second rotor arm extending radially outward from the rotary
15 output shaft to a second distal end;
 - an arcuate-shaped first piston disposed in said first piston housing assembly for reciprocal movement in the first piston housing assembly through the first open end along a first radius of curvature, wherein a first seal, the first cavity, and the first piston define a first pressure chamber,
20 and a first portion of the first piston connects to the first rotor arm at a first end portion; and
 - an arcuate-shaped second piston disposed in said second piston housing assembly for reciprocal movement in the second piston housing assembly through the second open end along a second radius of curvature,
25 wherein a second seal, the second cavity, and the second piston define a second pressure chamber, and a second portion of the second piston connects to the second rotor arm at a second end portion.
2. The rotary actuator of claim 1, wherein:
 - the first distal end comprises one or more first retainers;
 - the second distal end comprises one or more second retainers;
30 the first end portion comprises one or more third retainers;
 - the second end portion comprises one or more fourth retainers;

and

the first retainers, the second retainers, the third retainers, and the fourth retainers are intermeshed along the radius of curvature such that movement of the rotor assembly urges movement of the first piston and the second piston, and movement of the first piston and the second piston urges movement of the rotor assembly.

3. The rotary actuator of claim 1 or claim 2, wherein the second piston is oriented in the same rotational direction as the first piston.
4. The rotary actuator of claim 1 or claim 2, wherein the second piston is oriented in the opposite rotational direction as the first piston.
5. The rotary actuator of claim 1, further comprising an outer housing having a bore, the first piston housing assembly and the second piston housing assembly being assembled to the outer housing within the bore.
6. The rotary actuator of claim 1, further comprising at least one end cap assembled to at least one axial end of the first piston housing assembly and to at least one axial end of the second piston housing assembly.
7. The rotary actuator of any one of claims 1 to 6, wherein the first piston housing assembly and the second piston housing assembly are coupled to each other.
8. The rotary actuator of claim 2, further comprising a first connecting rod and wherein the first distal end further comprises a first bore, the first end portion further comprises a second bore, and the first connecting rod is located within the first bore and the second bore when the first retainers and the third retainers are intermeshed.
9. The rotary actuator of claim 8, wherein the first connecting rod, the first bore, and the second bore are configured with cross-sectional geometries that prevent rotation of the first connecting rod within the first bore and the second bore around the longitudinal axis of the connecting rod.

10. The rotary actuator of claim 8 or claim 9, further comprising a second connecting rod and wherein the second distal end further comprises a third bore, the second end portion further comprises a fourth bore, and the second connecting rod is located within the third bore and the fourth bore when the
5 second retainers and the fourth retainers are intermeshed.

11. The rotary actuator of claim 2, wherein at least one of the first retainers and the second retainers or the third retainers and the fourth retainers are formed with radial geometries that prevent rotation of the first piston or the second piston away from the radius of curvature.

10 12. The rotary actuator of claim 2, wherein at least one of the first retainers and the second retainers or the third retainers and the fourth retainers are connected by one or more fasteners that prevent rotation of the first piston or the second piston away from the radius of curvature.

13. A method of rotary actuation comprising:
15 providing a rotary actuator comprising:
a first piston housing assembly comprising a first cavity, a first fluid port in fluid communication with the first cavity, and a first open end;
a second piston housing assembly comprising a second cavity, a second fluid port in fluid communication with the second cavity, and a second
20 open end;
a rotor assembly rotatably journaled in said first piston housing assembly and said second piston housing assembly, and comprising:
a rotary output shaft;
a first rotor arm extending radially outward from the rotary output
25 shaft to a first distal end;
a second rotor arm extending radially outward from the rotary output shaft to a second distal end;
an arcuate-shaped first piston disposed in said first piston housing assembly for reciprocal movement in the first piston housing
30 assembly through the first open end along a first radius of curvature, wherein a first seal, the first cavity, and the first piston define a first pressure chamber,

and a first portion of the first piston connects to the first rotor arm at a first end portion; and

an arcuate-shaped second piston disposed in said second piston housing assembly for reciprocal movement in the second piston housing assembly through the second open end along a second radius of curvature, wherein a second seal, the second cavity, and the second piston define a second pressure chamber, and a second portion of the second piston connects to the second rotor arm at a second end portion, wherein movement of the rotor assembly urges movement of the first piston and the second piston, and movement of the first piston and the second piston urges movement of the rotor assembly;

urging a portion of the first piston partially out of the first pressure chamber to urge rotation of the rotary output shaft in a first direction;

rotating the rotary output shaft in a second direction opposite that of the first direction; and,

urging the first piston partially into the first pressure chamber to urge pressurized fluid out the first fluid port.

14. The method of claim 13, wherein providing a rotary actuator comprises providing a rotary actuator wherein:

the first distal end comprises one or more first retainers;
the second distal end comprises one or more second retainers;
the first end portion comprises one or more third retainers; and
the first retainers, the second retainers, and the third retainers are intermeshed along the radius of curvature.

15. The method of claim 13 or claim 14, wherein providing a rotary actuator comprises providing a rotary actuator wherein the second piston is oriented in the same rotational direction as the first piston.

16. The method of claim 13 or claim 14, wherein providing a rotary actuator comprises providing a rotary actuator wherein the second piston is oriented in the opposite rotational direction as the first piston.

17. The method of claim 13, wherein providing a rotary actuator comprises providing an outer housing having a bore, the first piston housing assembly and the second piston housing assembly being assembled to the outer housing within the bore.
- 5 18. The method of claim 13, wherein providing a rotary actuator comprises providing at least one end cap assembled to at least one axial end of the first piston housing assembly and to at least one axial end of the second piston housing assembly.
19. The method of any one of claims 13 to 18, wherein providing a rotary
10 actuator comprises providing a rotary actuator wherein the first piston housing assembly and the second piston housing assembly are coupled to each other.
20. The method of claim 14, wherein providing a rotary actuator further comprises providing a first connecting rod and wherein the first distal end further comprises a first bore, the first end portion further comprises a second
15 bore, and the first connecting rod is located within the first bore and the second bore when the first retainers and the third retainers are intermeshed.
21. The method of claim 20, wherein providing a rotary actuator comprises providing a rotary actuator wherein the first connecting rod, the first bore, and the second bore are configured with cross-sectional geometries that prevent
20 rotation of the first connecting rod within the first bore and the second bore around the longitudinal axis of the connecting rod.
22. The method of claim 20 or claim 21, wherein providing a rotary actuator further comprises providing a second connecting rod and wherein the second distal end further comprises a third bore, the second end portion further
25 comprises a fourth bore, and the second connecting rod is located within the third bore and the fourth bore when the second retainers and the fourth retainers are intermeshed.
23. The method of claim 14, providing a rotary actuator comprises providing a rotary actuator wherein at least one of the first retainers and the second

retainers or the third retainers and the fourth retainers are formed with radial geometries that prevent rotation of the first piston or the second piston away from the radius of curvature.

24. The method of claim 14, providing a rotary actuator comprises providing
5 a rotary actuator wherein at least one of the first retainers and the second retainers or the third retainers and the fourth retainers are connected by one or more fasteners that prevent rotation of the first piston or the second piston away from the radius of curvature.

25. A rotary actuator comprising:
10 a first piston housing comprising a first cavity, a fluid port in fluid communication with the first cavity, and an open end;
a housing assembly comprising:
a first outer housing comprising a first recess formed to partly accommodate the first piston housing;
15 a second outer housing comprising a second recess formed to partly accommodate the first piston housing, wherein the second outer housing is configured to be assembled to the outer housing such that the first recess and the second recess define a second cavity configured to accommodate the first piston housing; and
20 an arcuate-shaped first piston disposed in said first piston housing for reciprocal movement in the first piston housing through the open end along a radius of curvature, wherein a first seal, the first cavity, and the first piston define a pressure chamber.

26. The rotary actuator of claim 25, further comprising:
25 a second piston housing comprising a third cavity, a fluid port in fluid communication with the third cavity, and an open end; and
a fluid conduit connecting the first cavity and the third cavity;
wherein the second cavity is further configured to accommodate the second piston housing.

30 27. A method of assembling a rotary actuator comprising:
providing a first piston housing comprising a first cavity, a fluid port in

fluid communication with the cavity, and an open end;

providing a housing assembly comprising:

a first outer housing comprising a first recess formed to partly accommodate the first piston housing;

5 a second outer housing comprising a second recess formed to partly accommodate the first piston housing, wherein the second outer housing is configured to be assembled to the first outer housing such that the first recess and the second recess define a second cavity configured to accommodate the first piston housing; and

10 providing an arcuate-shaped first piston disposed in said first piston housing for reciprocal movement in the first piston housing through the open end along a radius of curvature, wherein a first seal, the first cavity, and the first piston define a first pressure chamber;

inserting a portion of the first piston at least partly into the first pressure chamber; and

15 positioning the first piston housing within the first recess and the second recess such that the second cavity is defined and the first piston housing is accommodated within the second cavity.

28. The method of claim 27, further comprising:

20 providing a second piston housing comprising a third cavity, a fluid port in fluid communication with the cavity, and an open end;

providing a fluid conduit connecting the first cavity and the third cavity;

providing an arcuate-shaped second piston disposed in said second piston housing for reciprocal movement in the second piston housing through the open end along a radius of curvature, wherein a second seal, the second cavity, and the second piston define a second pressure chamber; wherein the second cavity is further configured to accommodate the second piston housing;

25 inserting a portion of the second piston at least partly into the second pressure chamber; and

30 positioning the second piston housing within the first recess and the second recess such that the second cavity is defined and the first piston

housing and the second piston housing are accommodated within the second cavity.

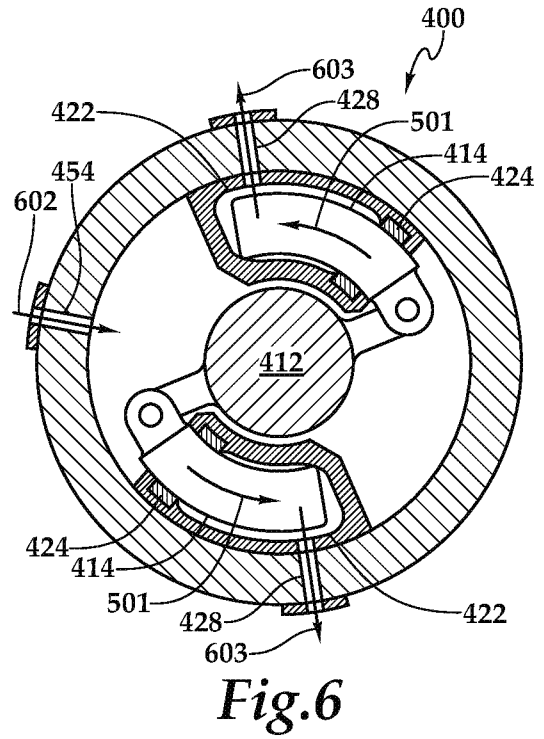
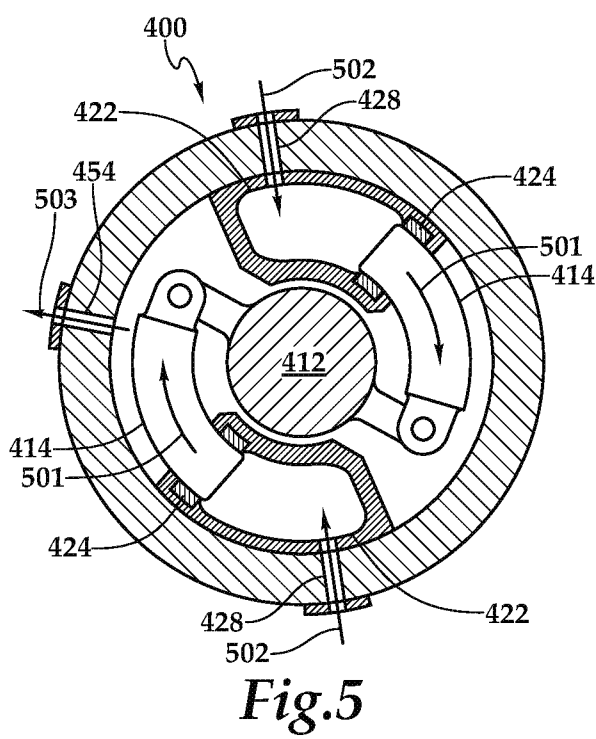
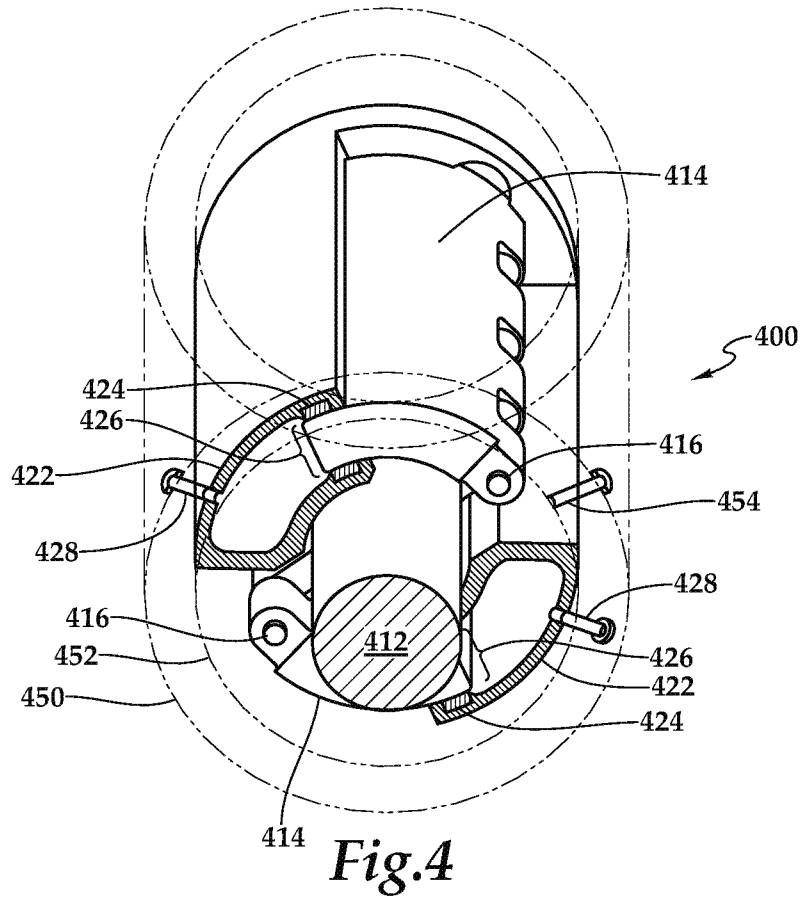

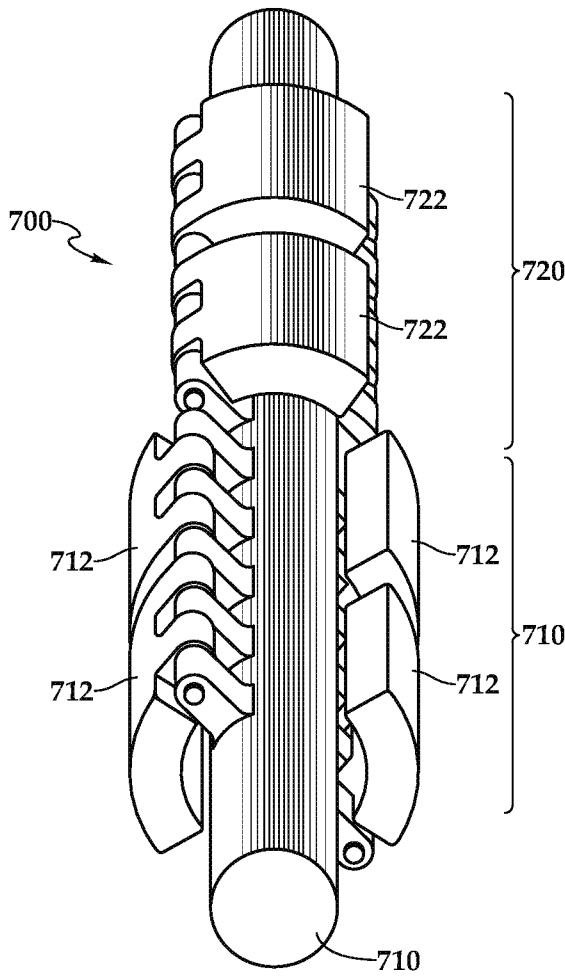

Fig.7

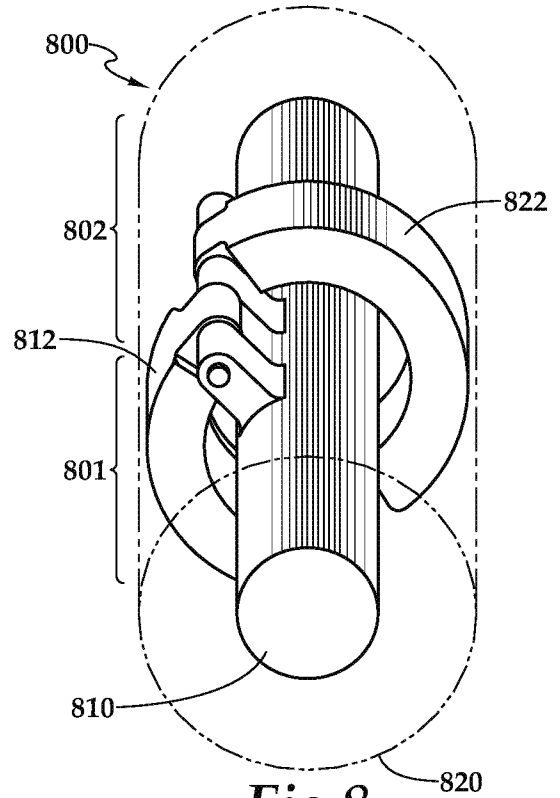

Fig.8

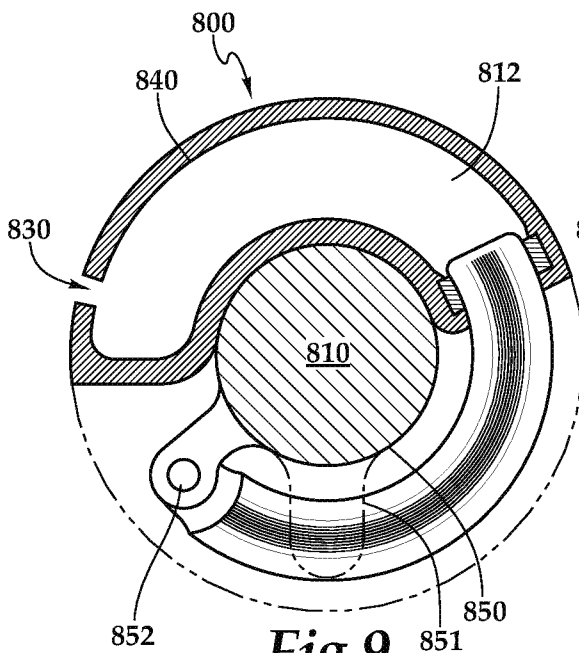

Fig.9

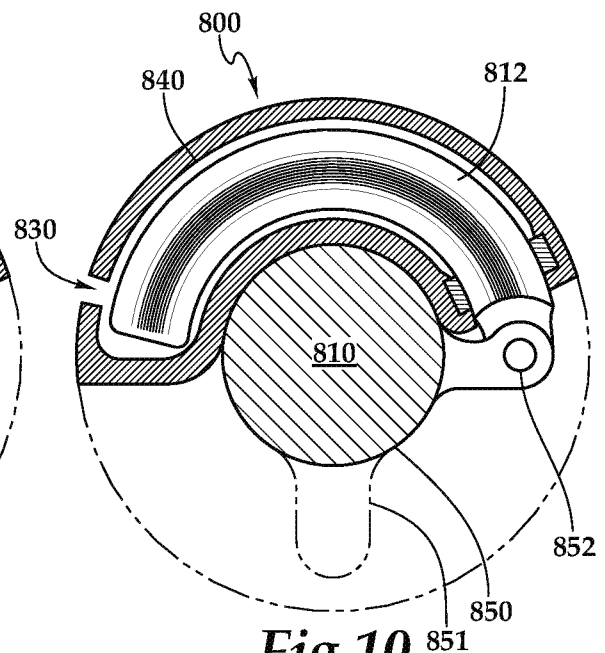

Fig.10

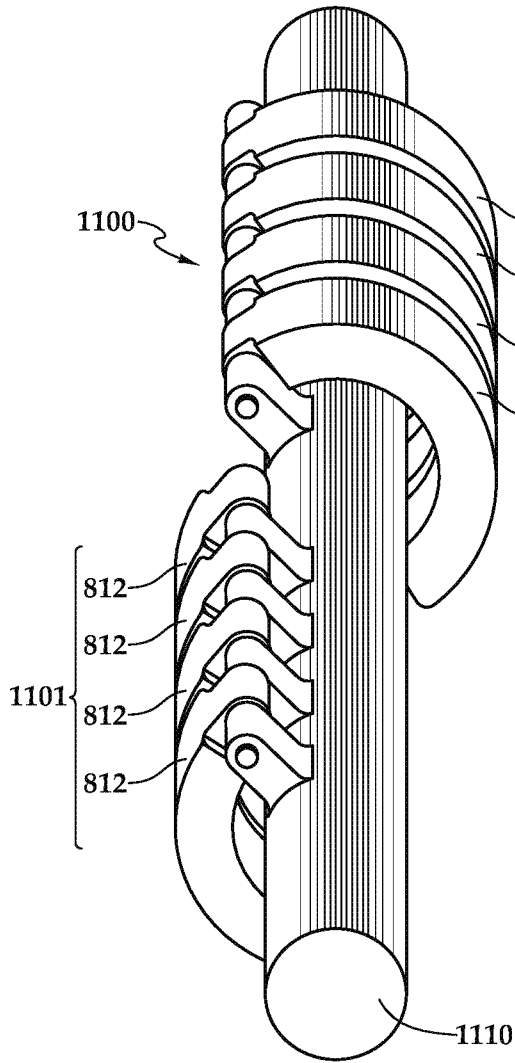

Fig.11

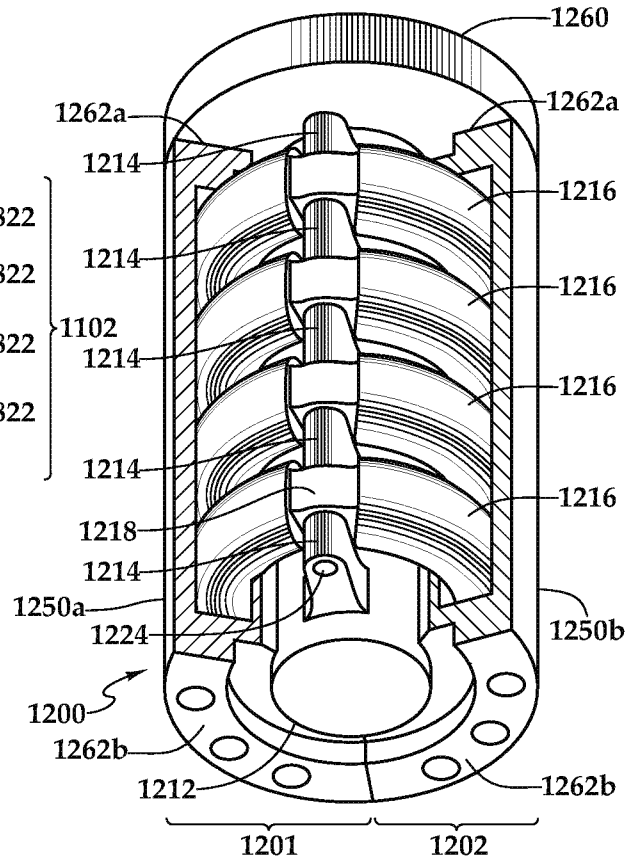

Fig.12

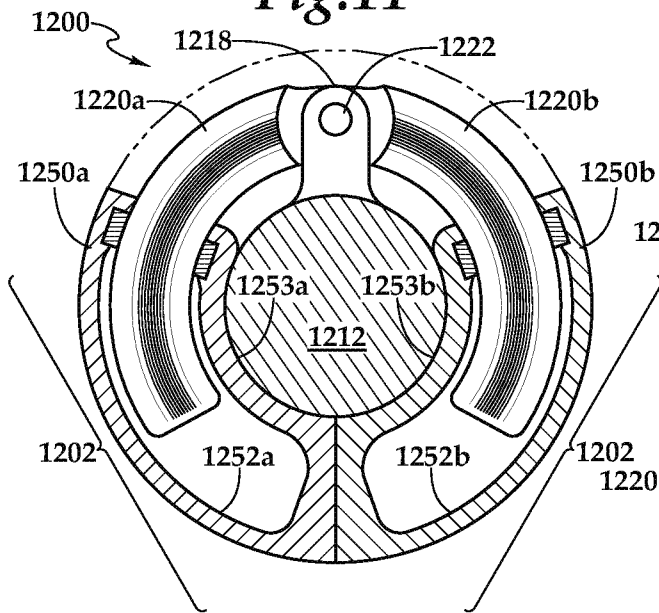

Fig.14

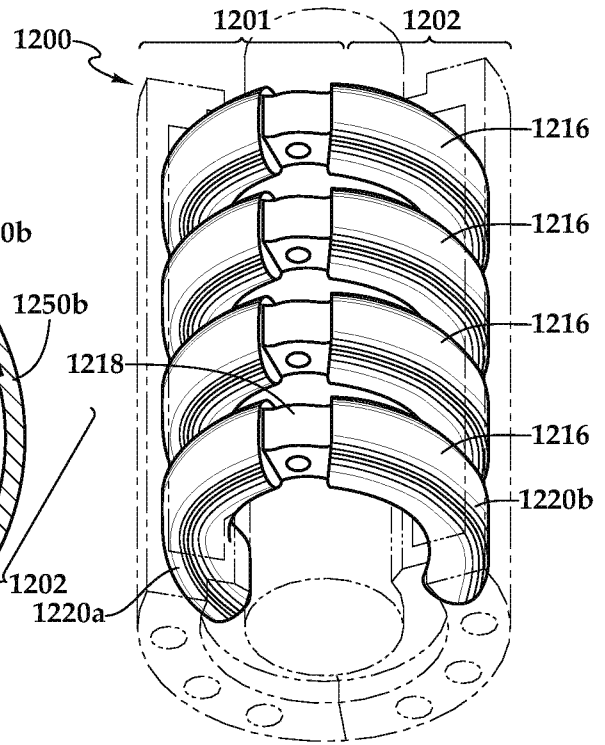

Fig.13

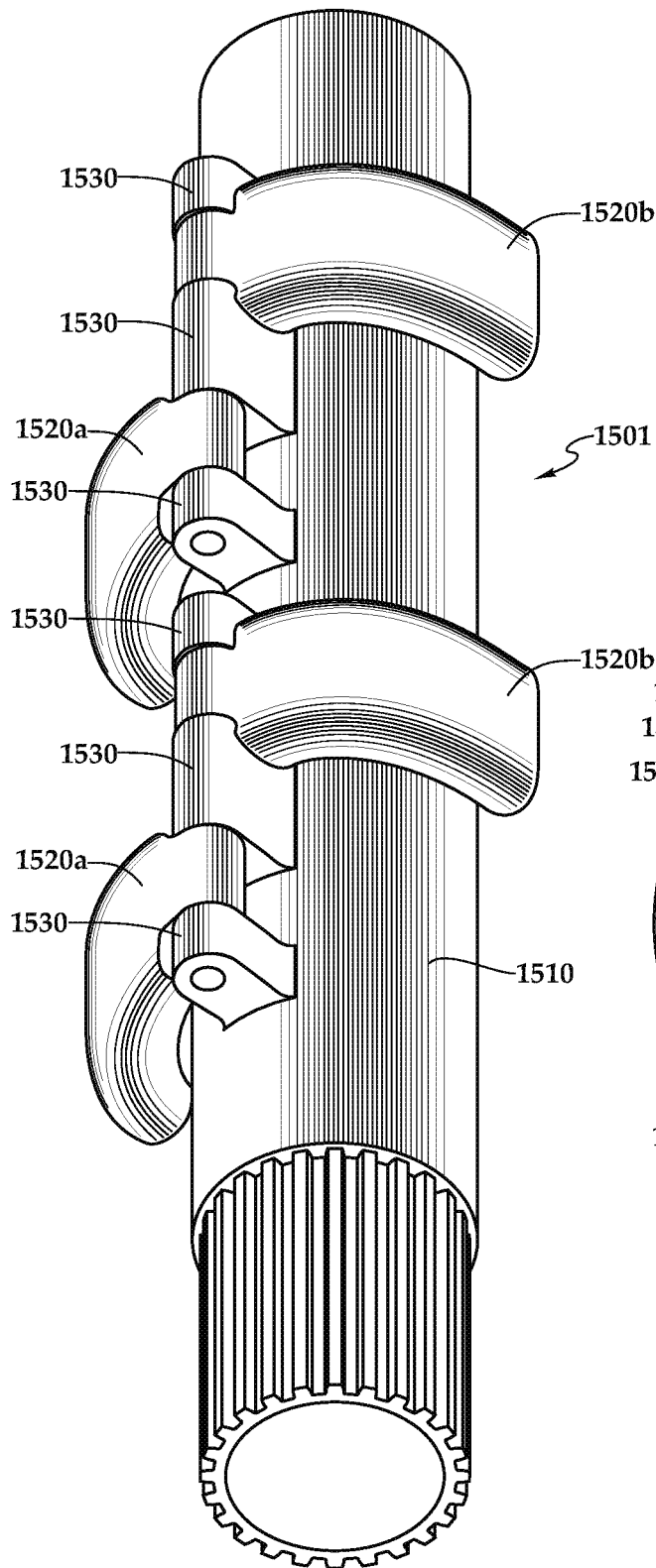

Fig.15

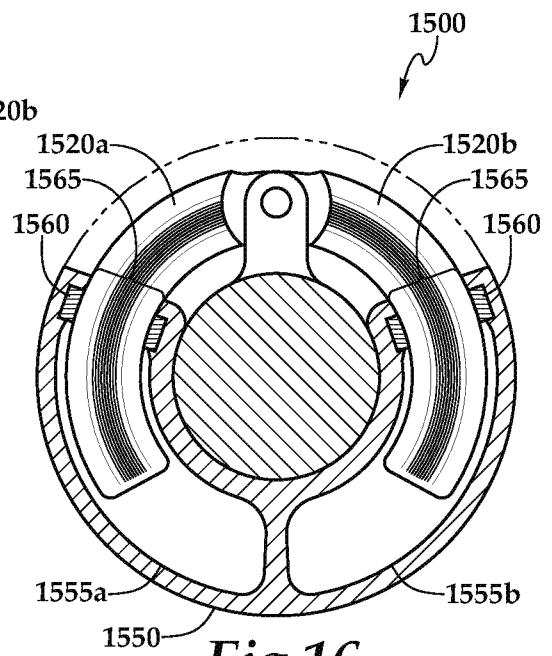

Fig.16

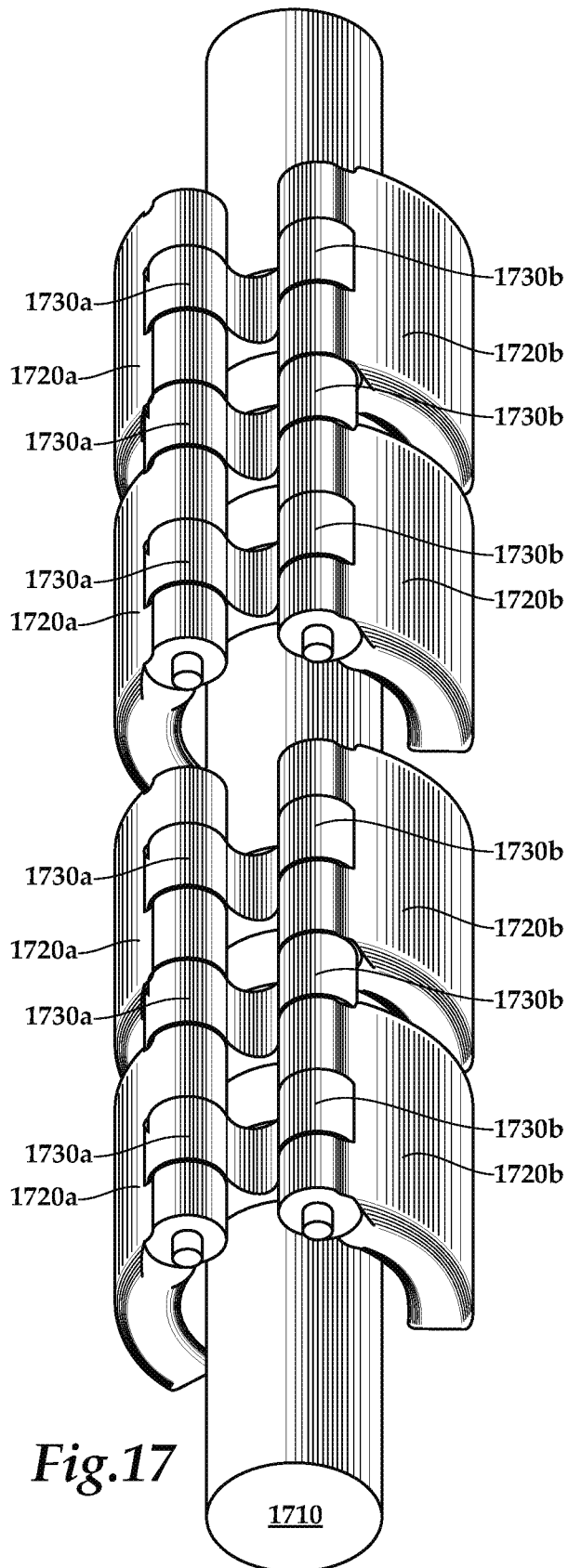

Fig.17

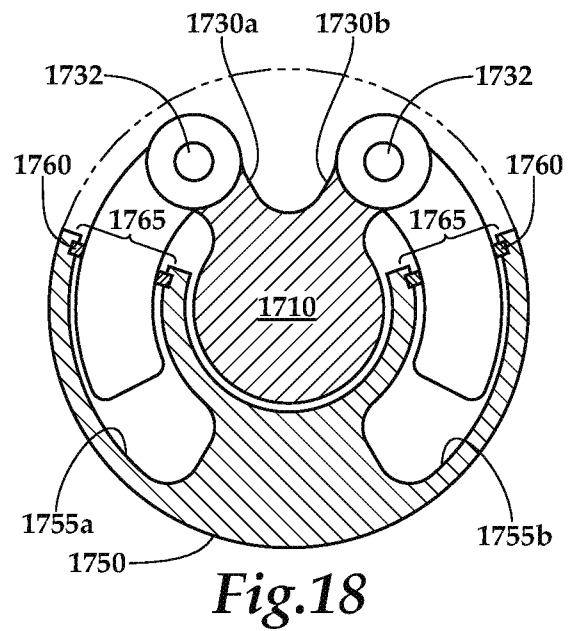
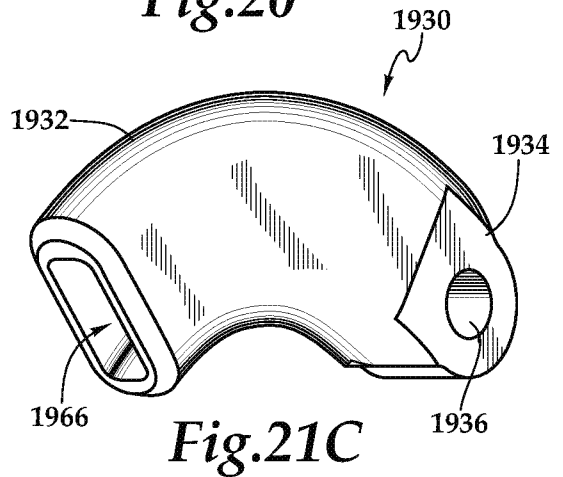
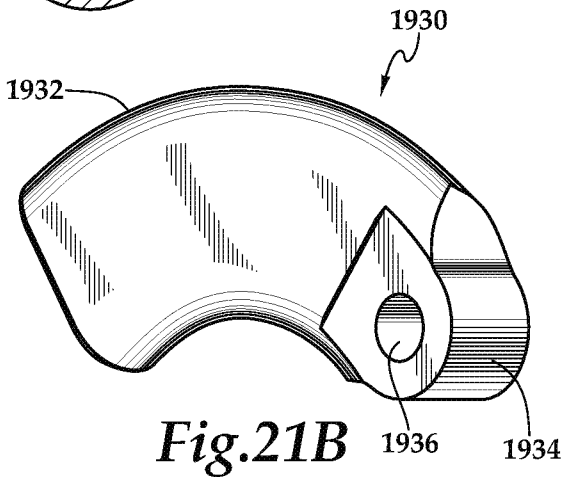
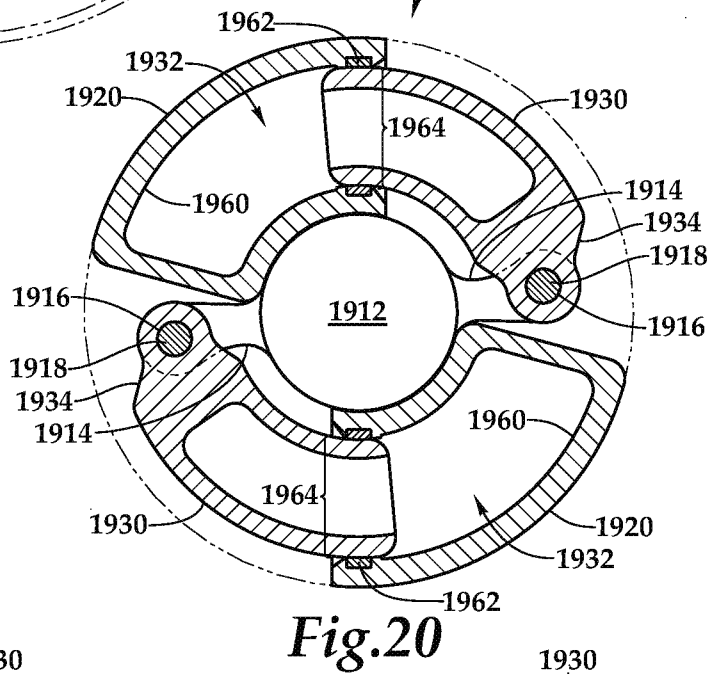
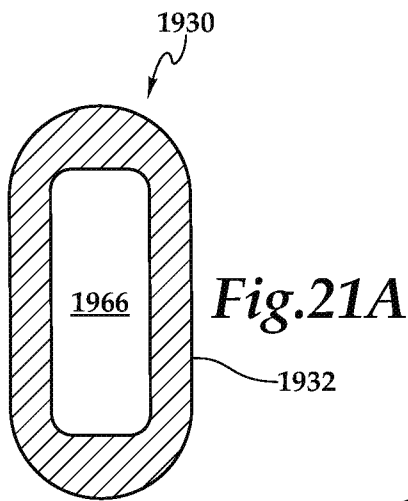
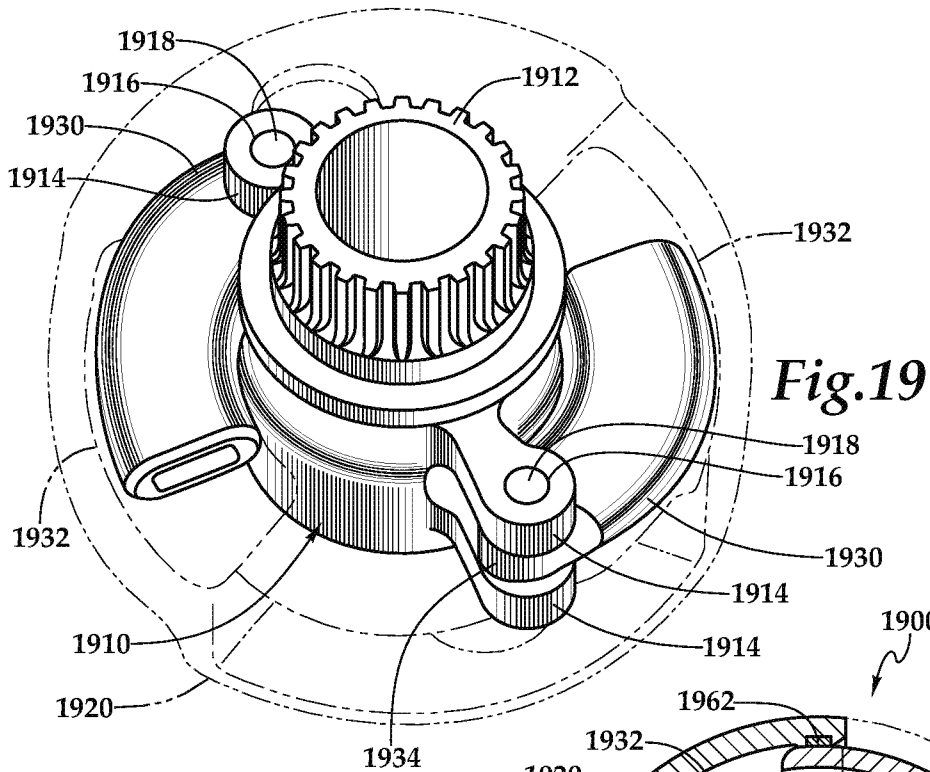

Fig.18



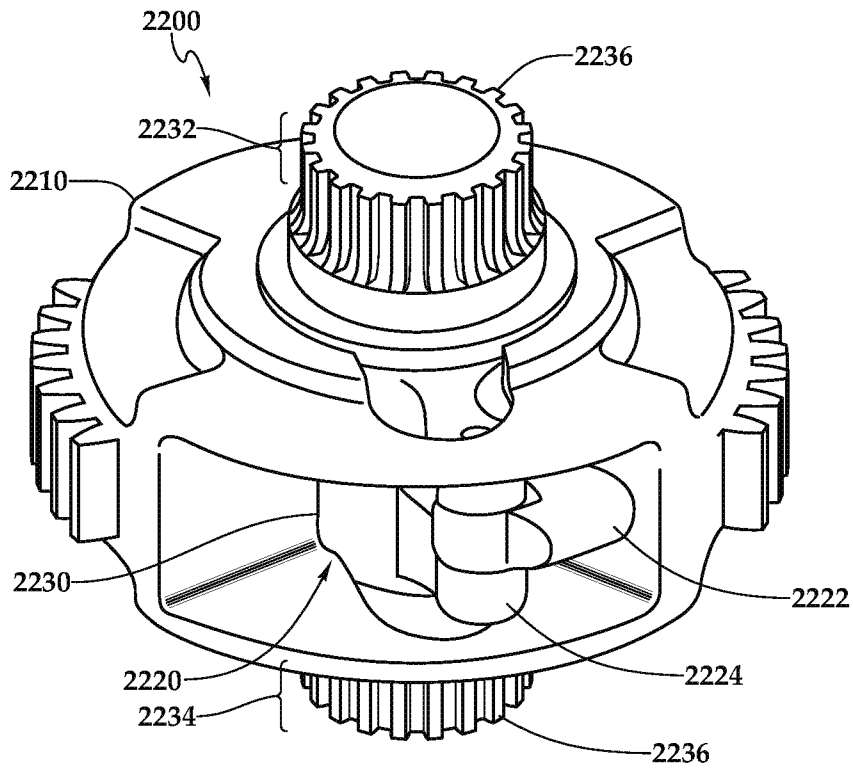

Fig. 22

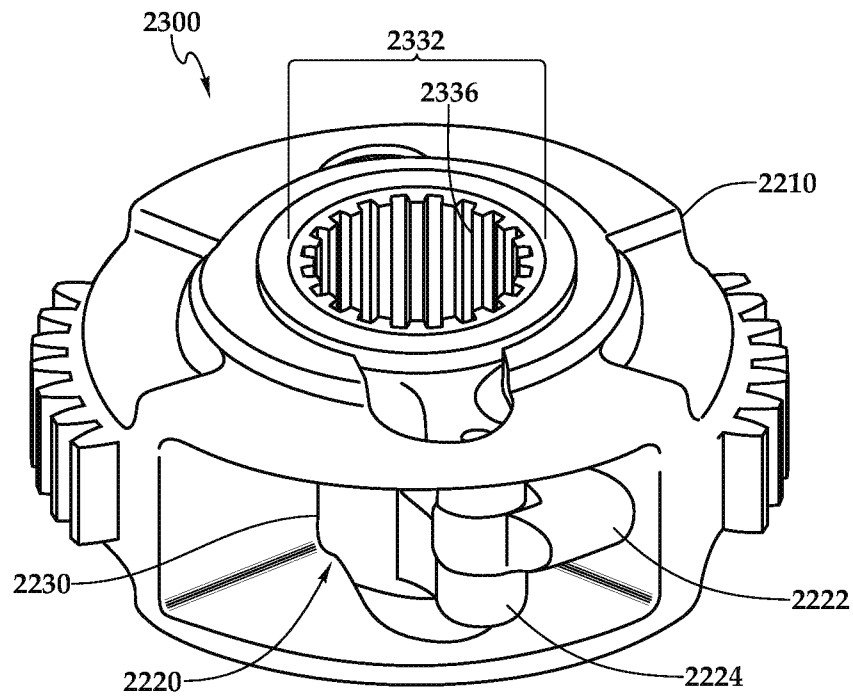
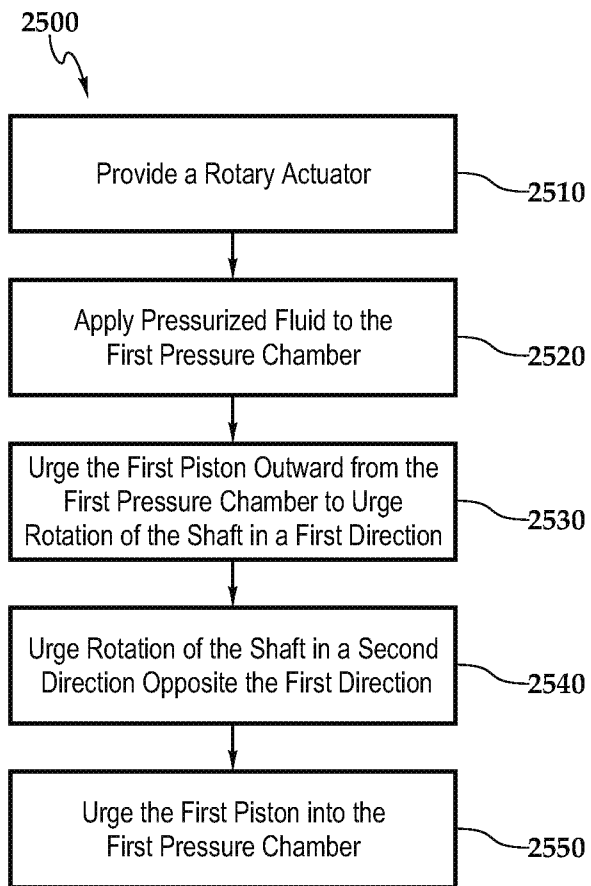
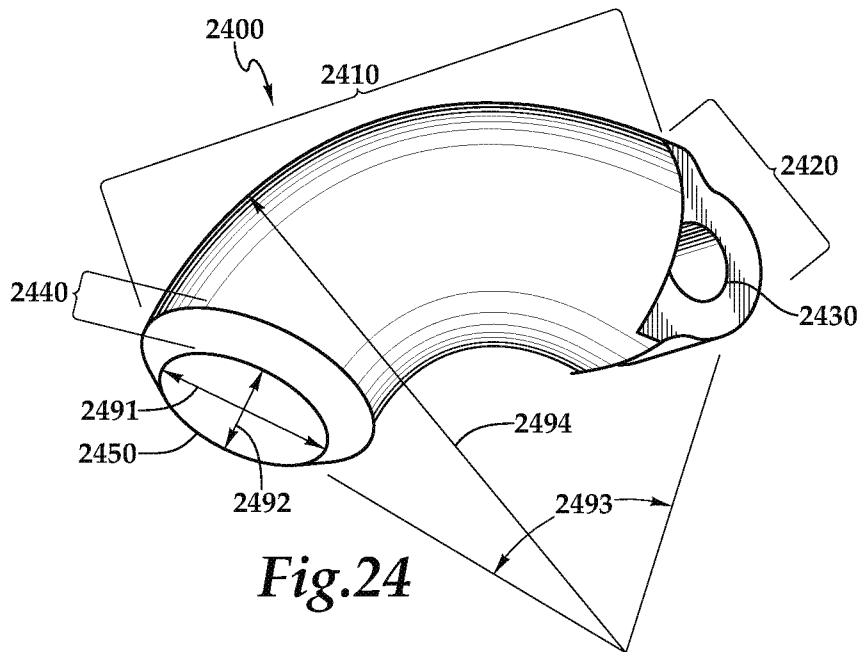

Fig. 23



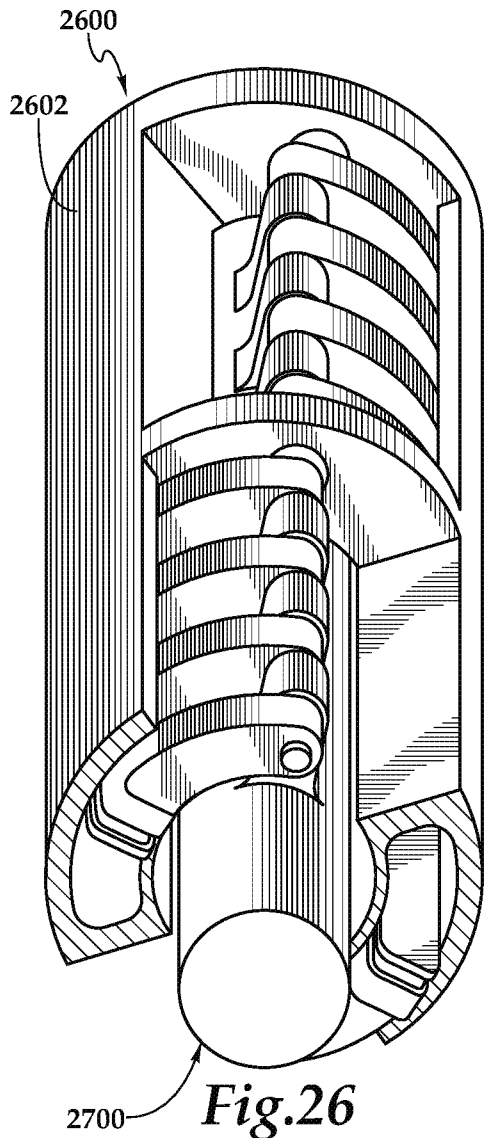

Fig.26

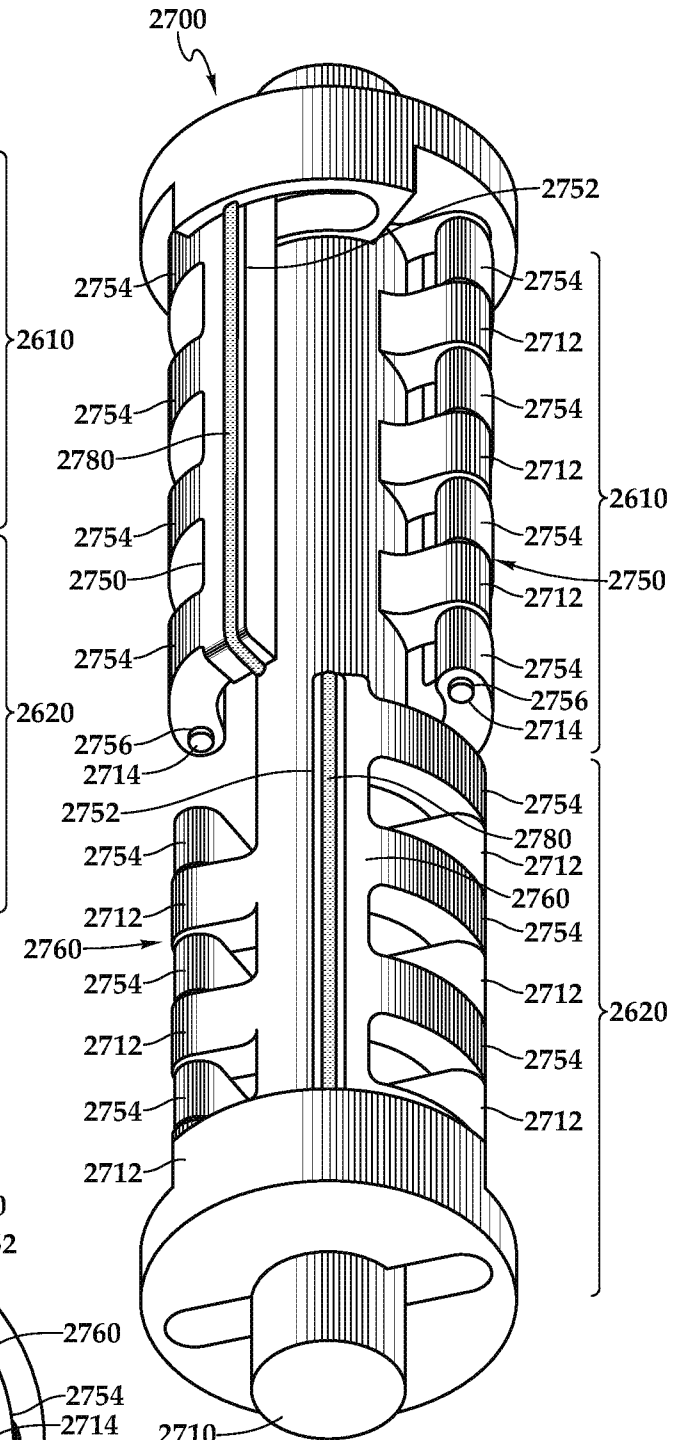

Fig.27

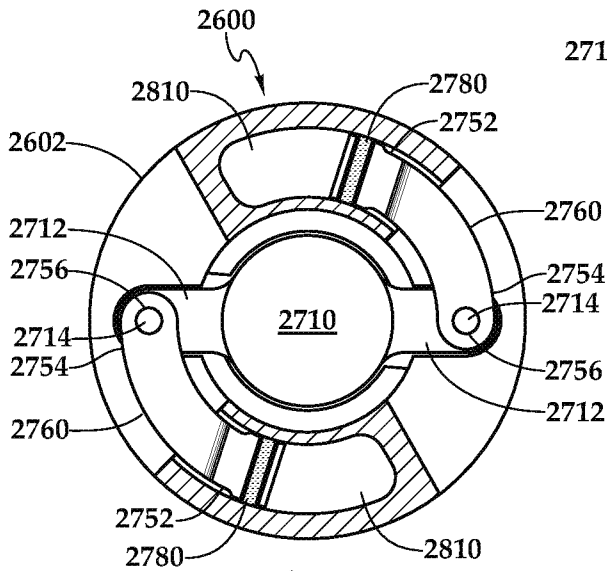

Fig.28

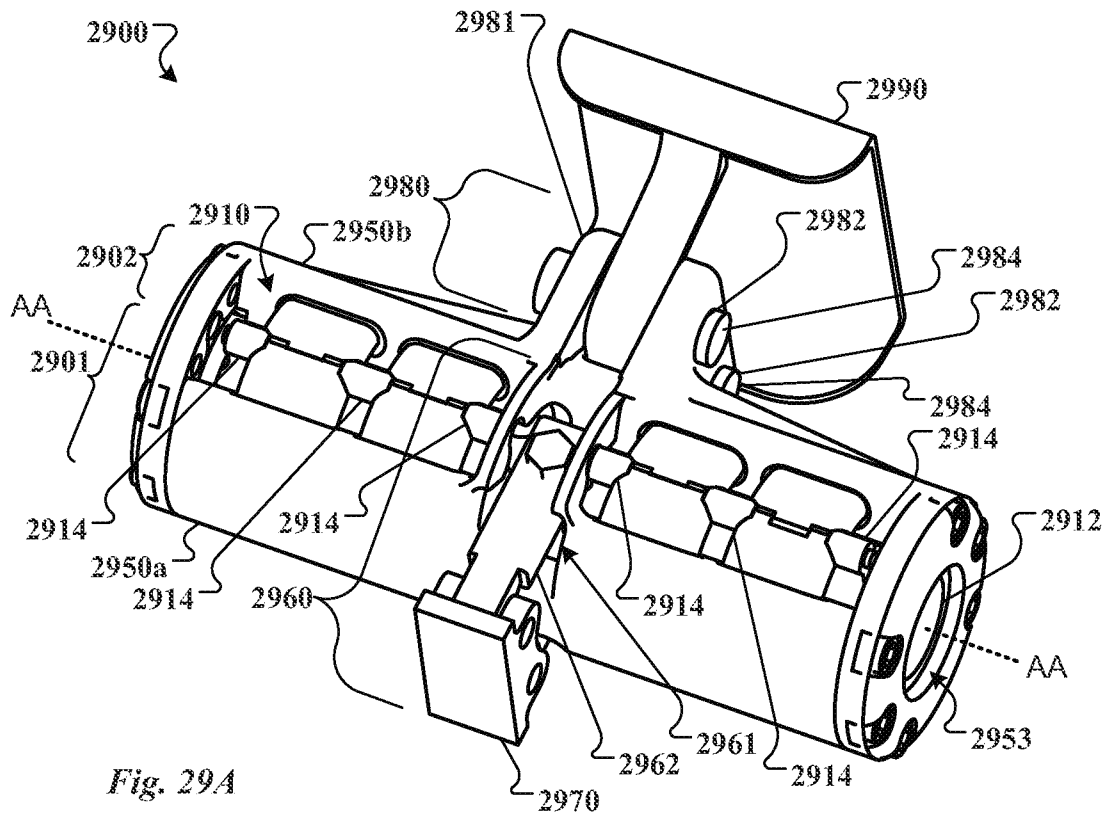

Fig. 29A

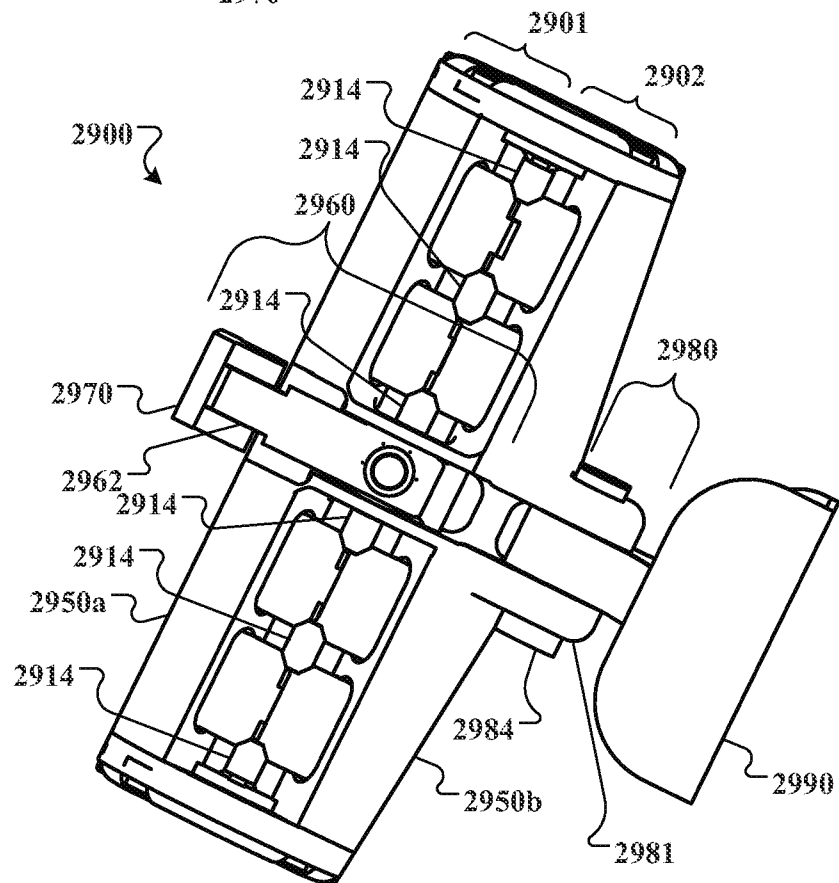

Fig. 29B

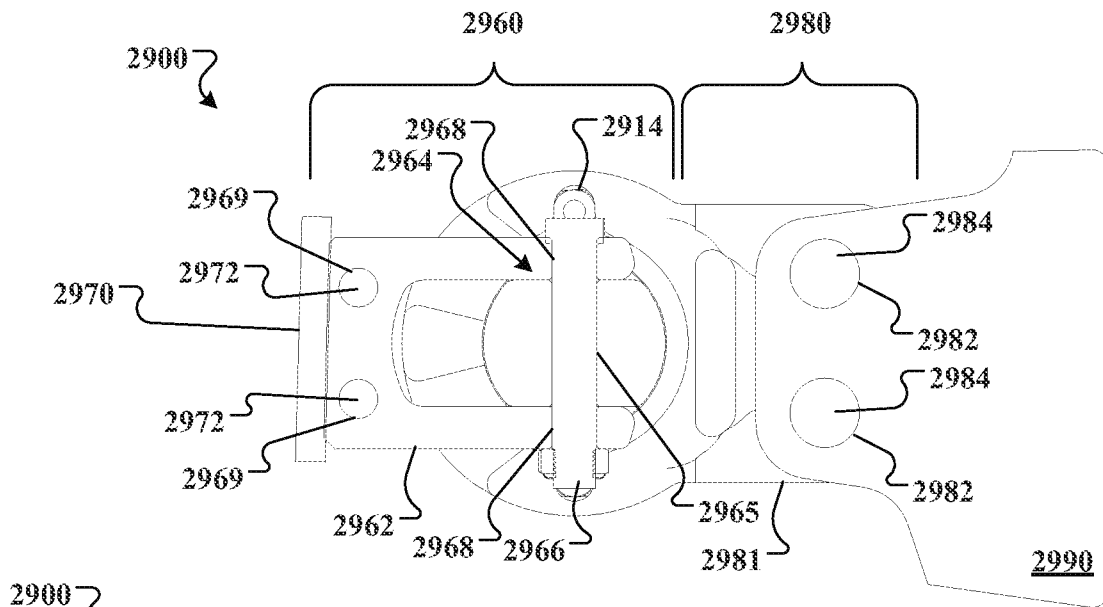

Fig. 29D

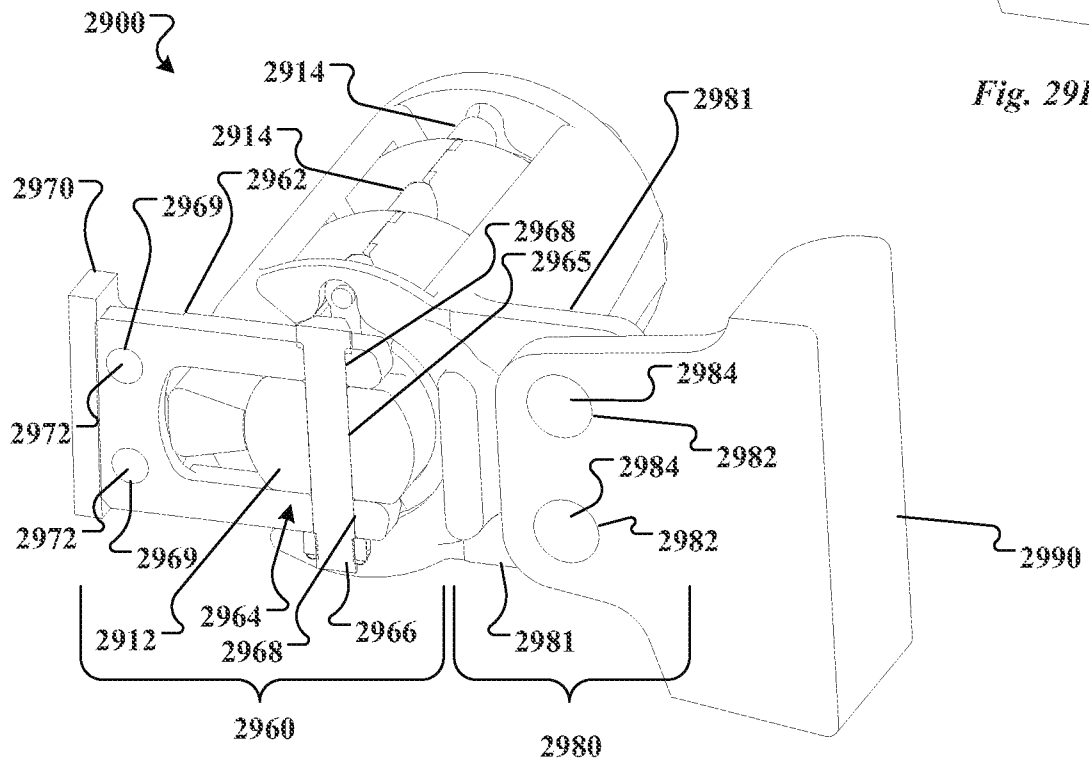

Fig. 29E

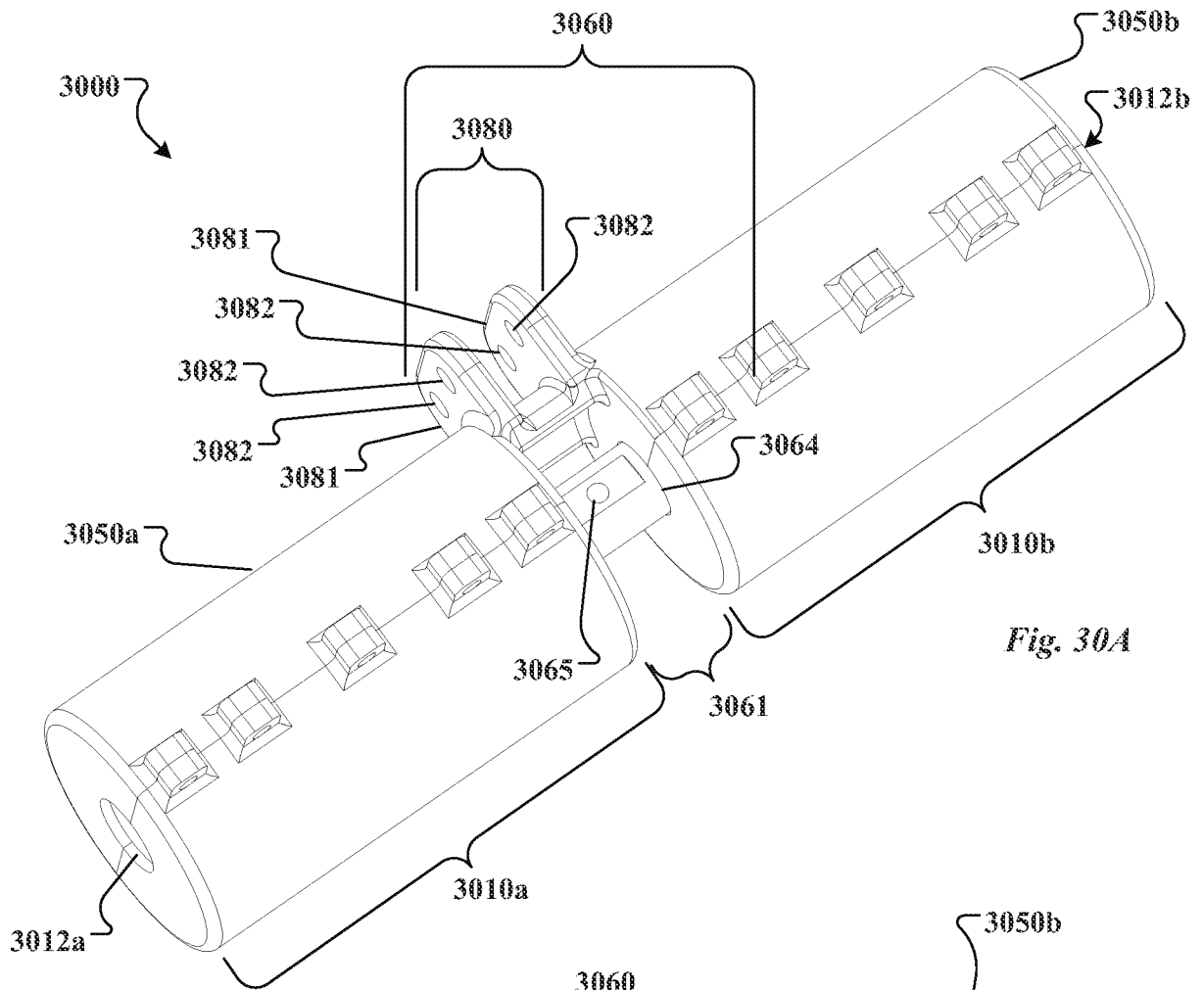

Fig. 30A

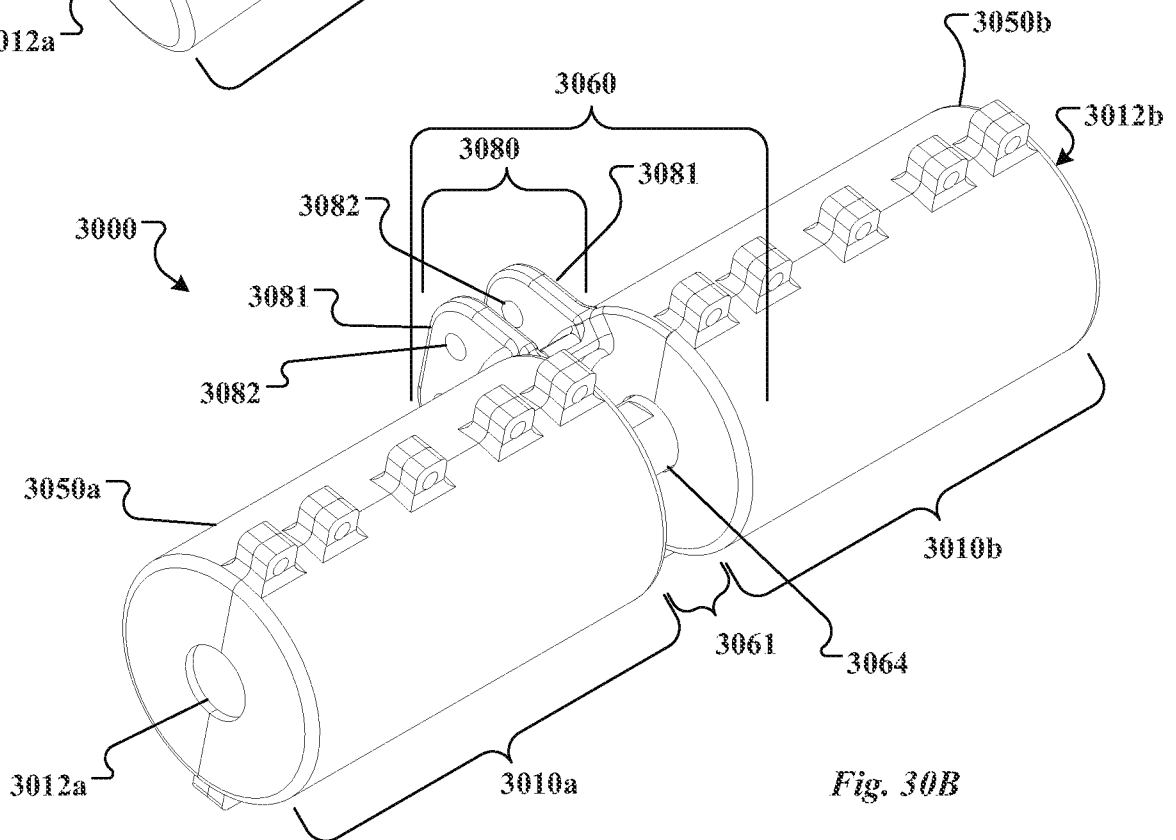
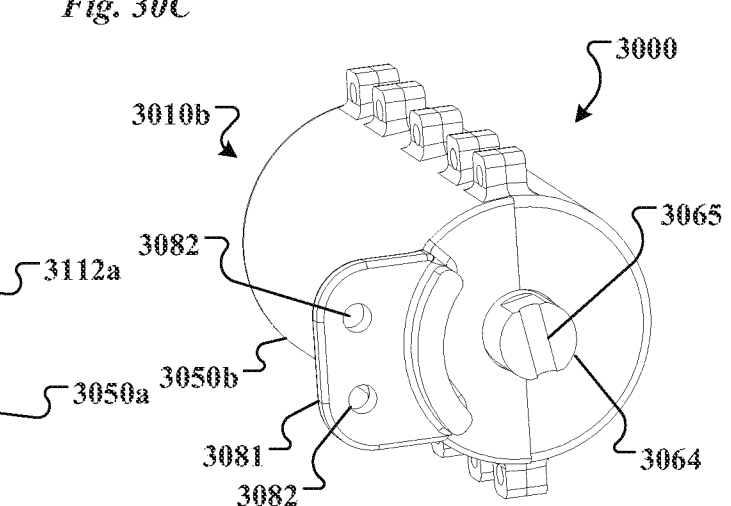
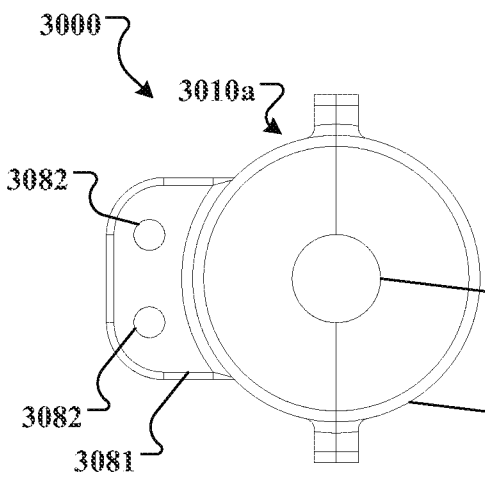
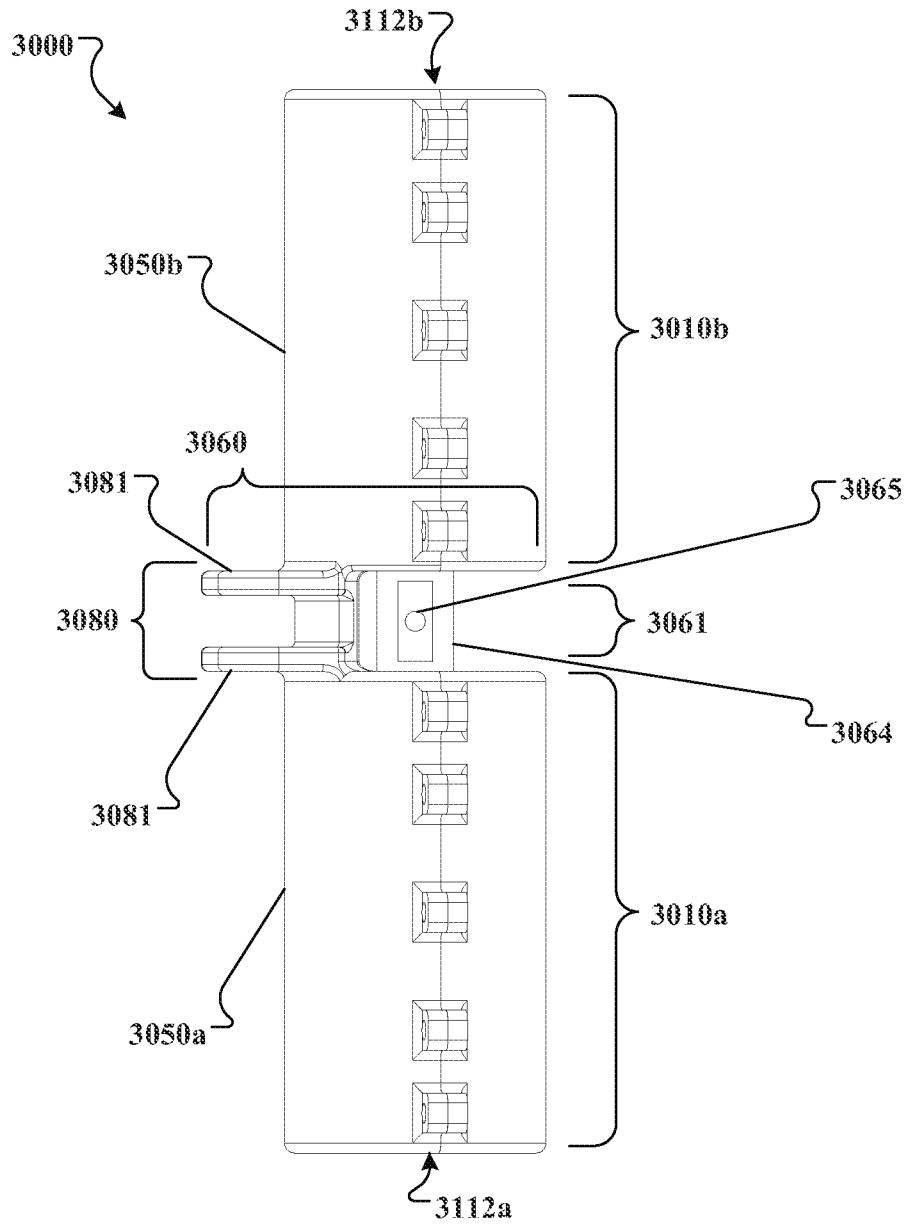
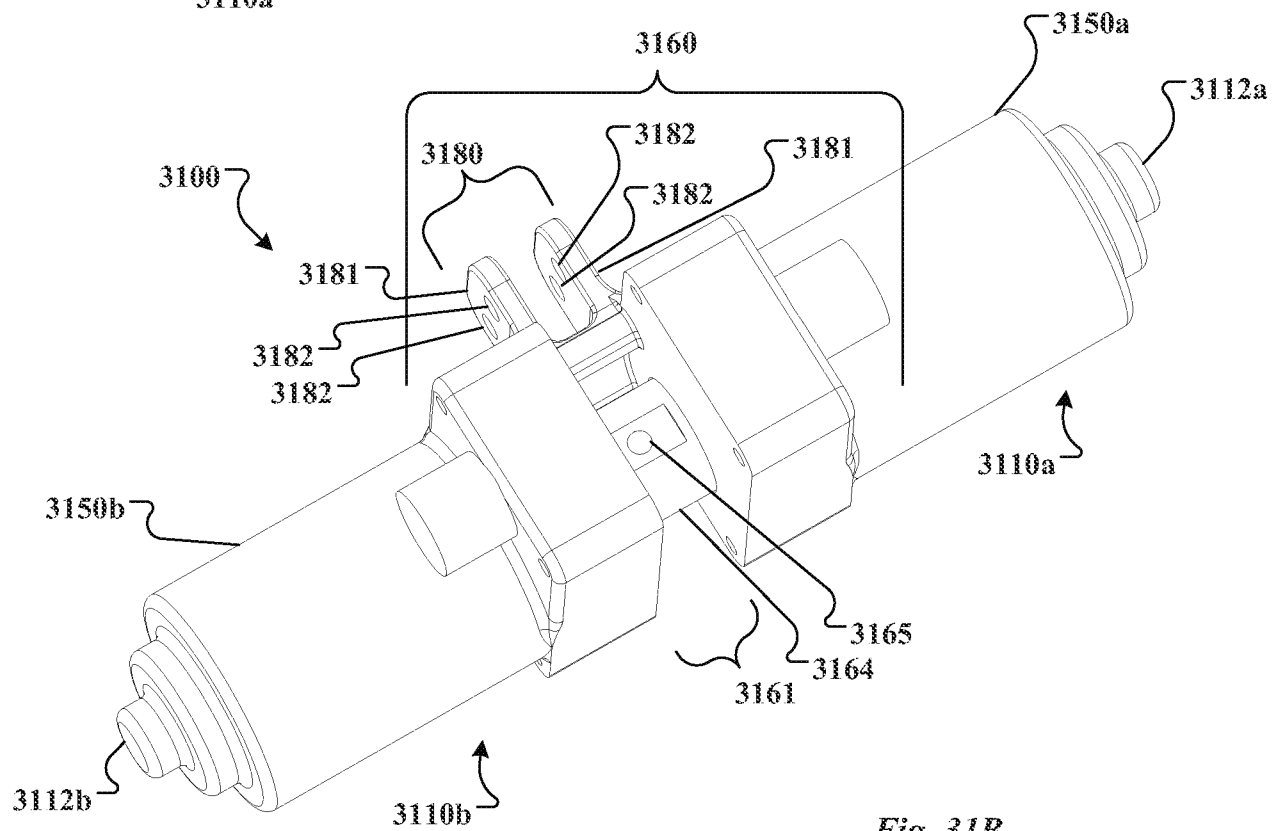
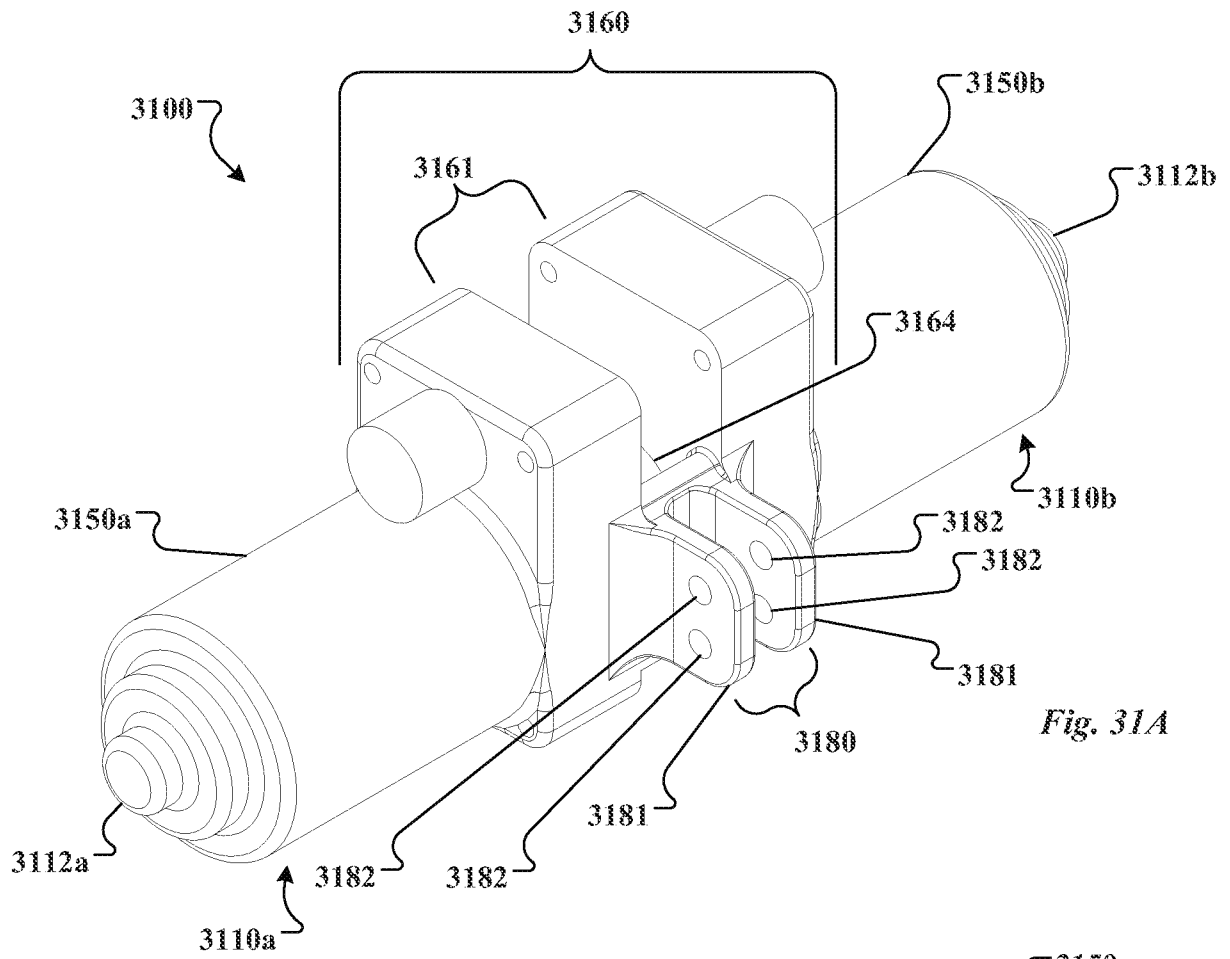

Fig. 30B





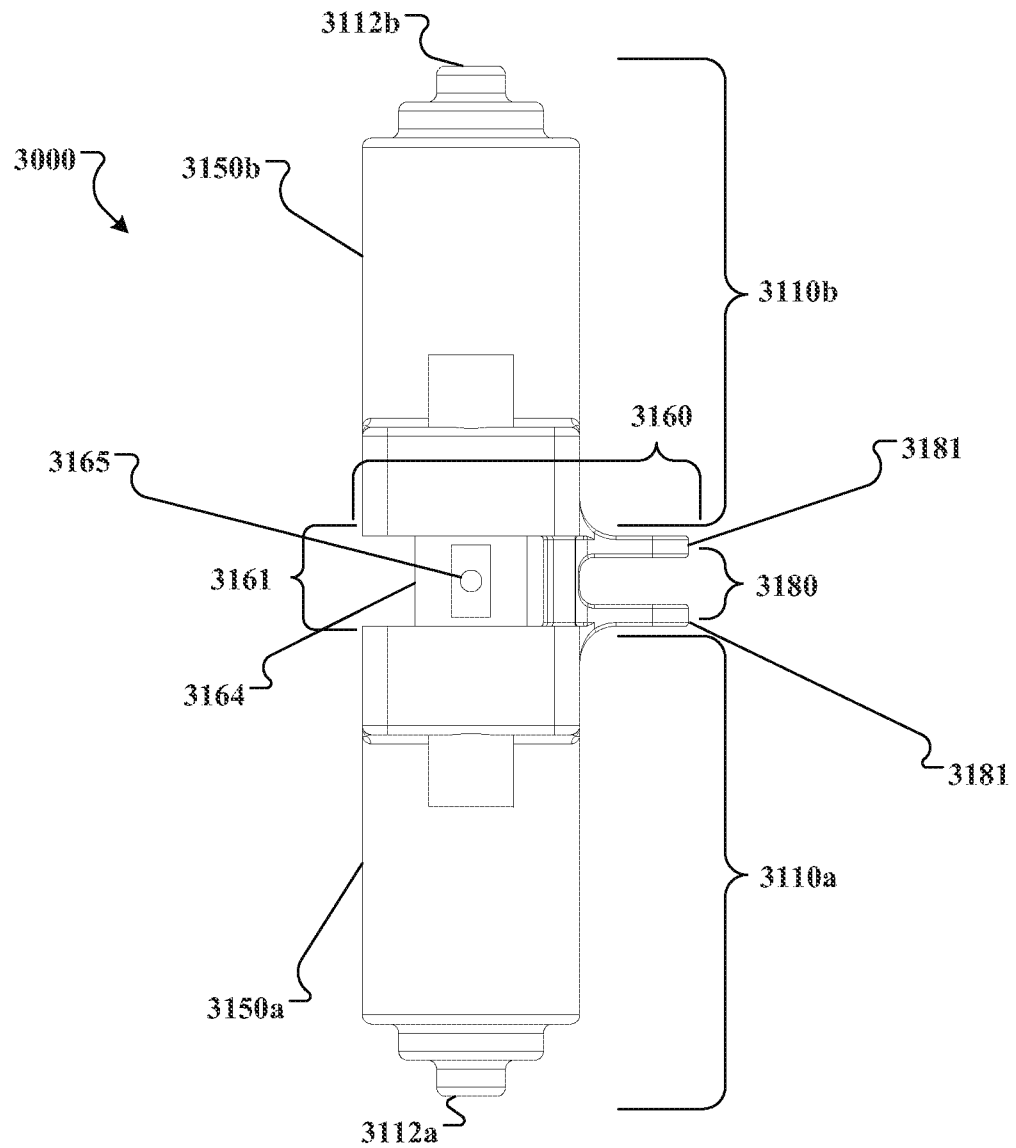

Fig. 31C

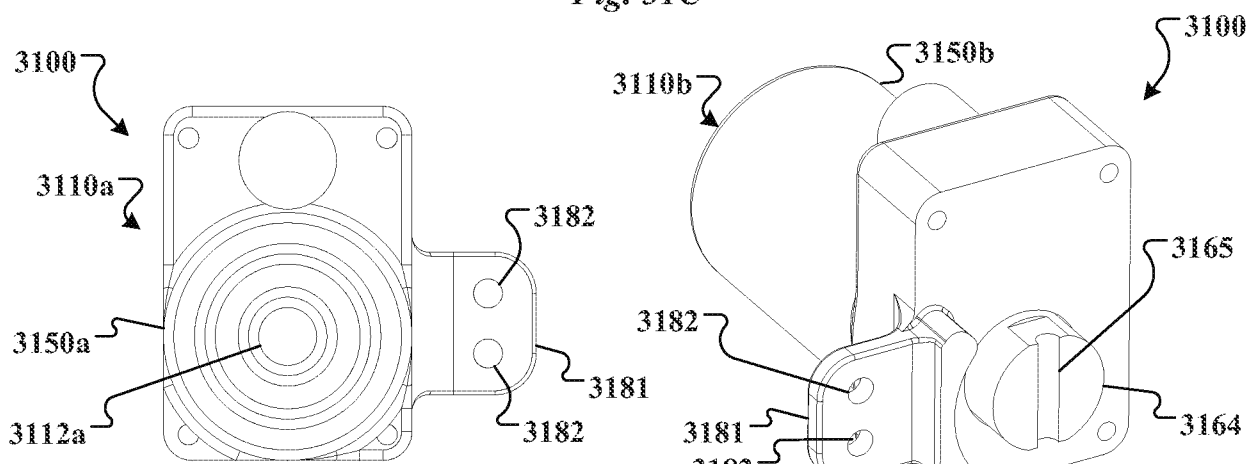

Fig. 31D

Fig. 31E

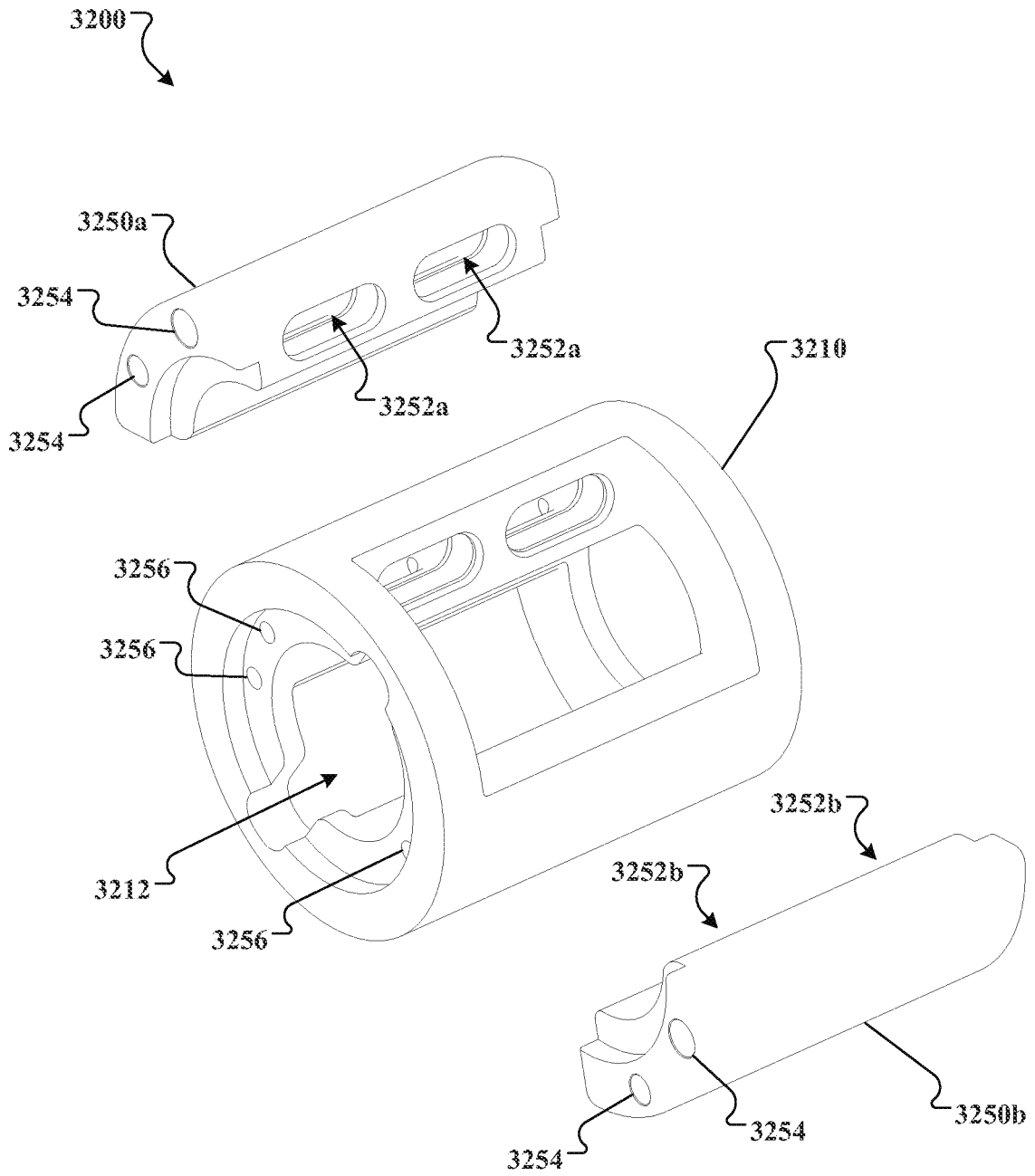

Fig. 32

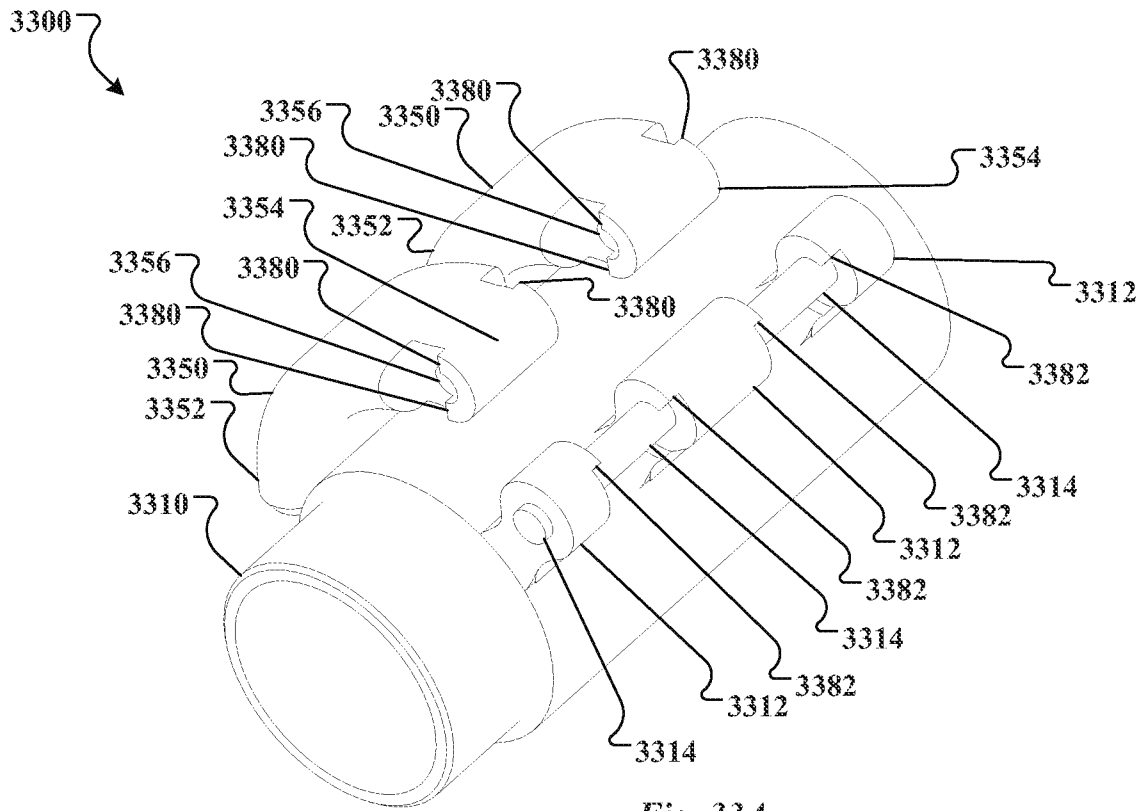

Fig. 33A

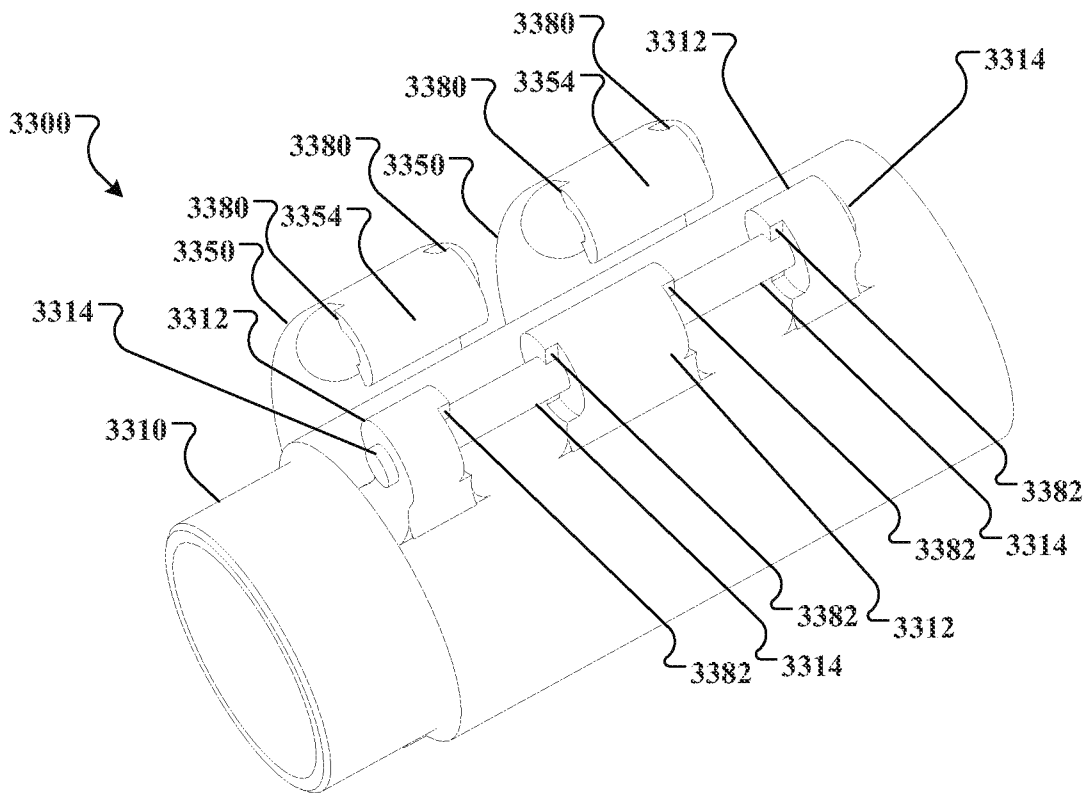

Fig. 33B

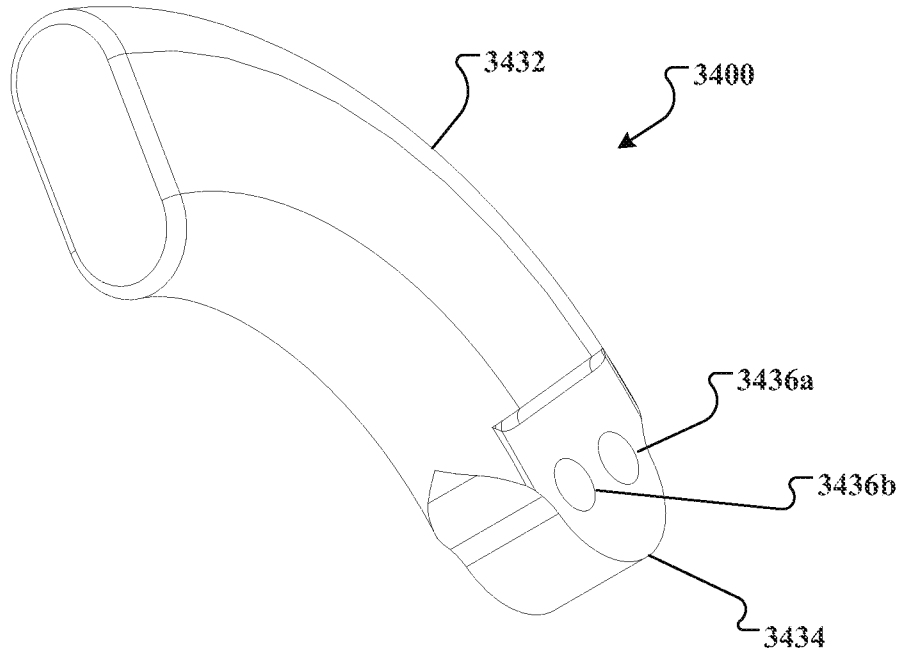

Fig. 34A

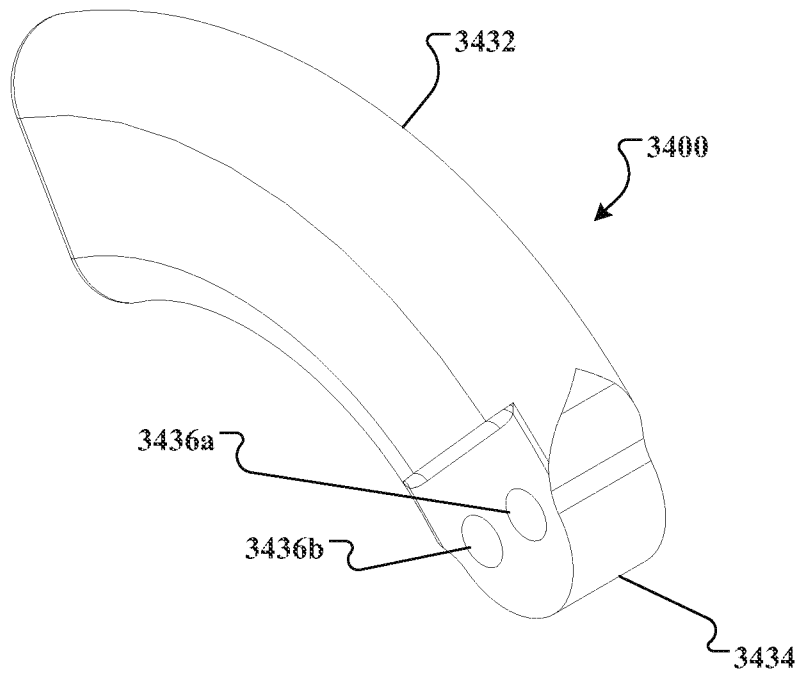

Fig. 34B

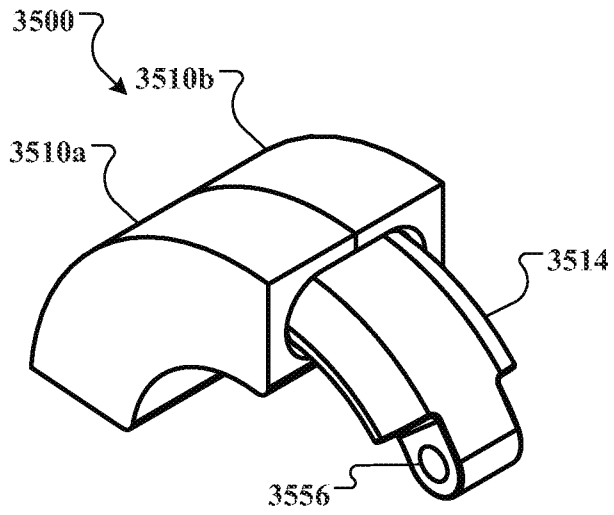

Fig. 35A

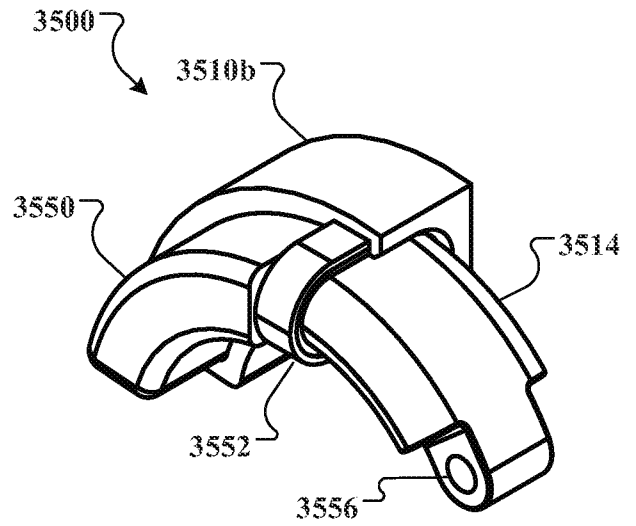

Fig. 35B

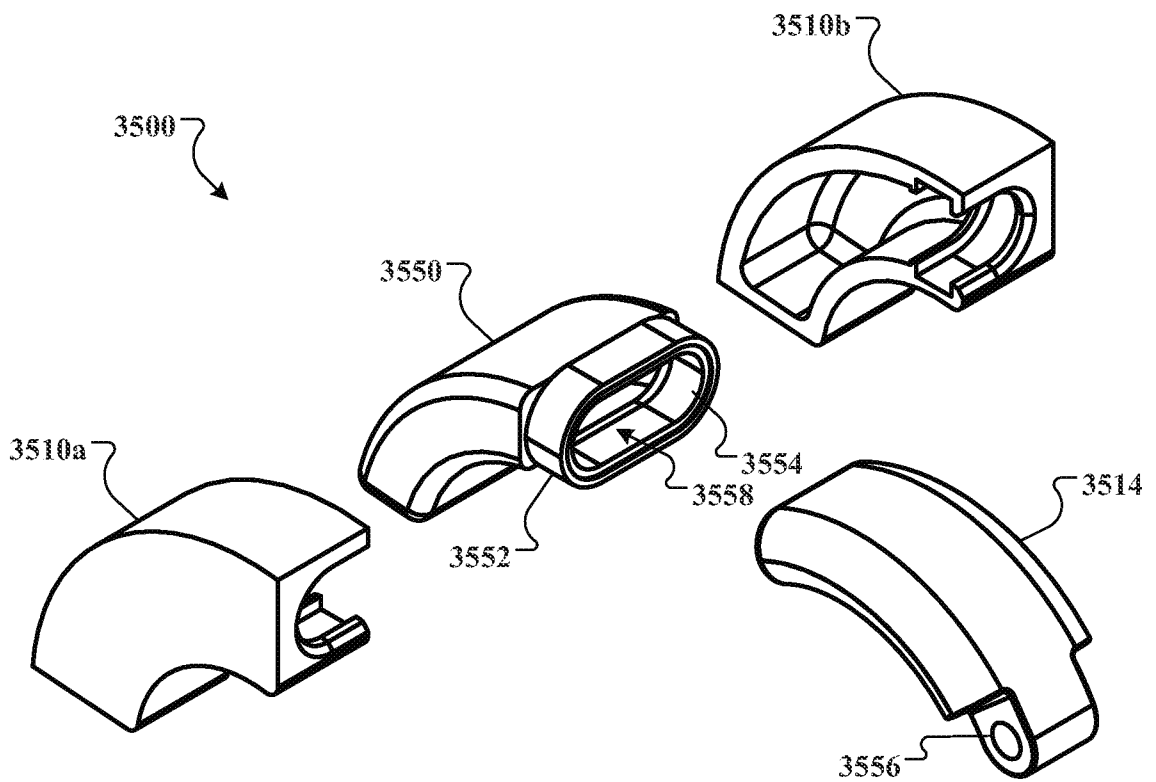

Fig. 35C

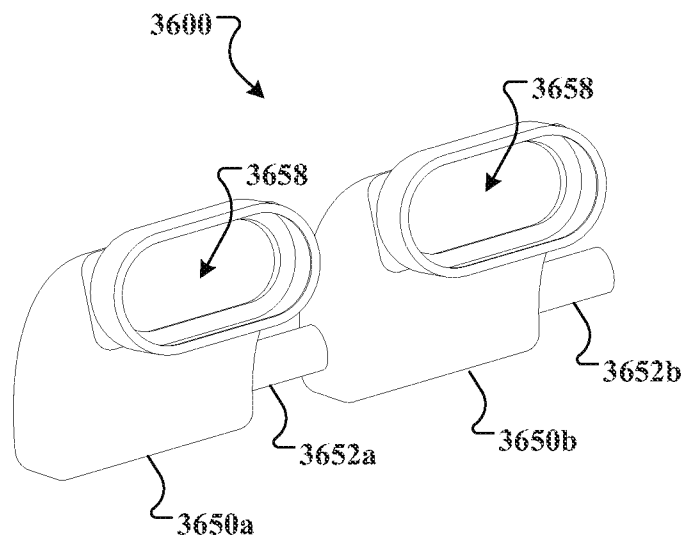

Fig. 36