

(19) World Intellectual Property Organization
International Bureau



(43) International Publication Date
2 March 2006 (02.03.2006)

PCT

(10) International Publication Number
WO 2006/023270 A2

- (51) International Patent Classification:
B30B 9/02 (2006.01)
- (21) International Application Number:
PCT/US2005/027466
- (22) International Filing Date: 3 August 2005 (03.08.2005)
- (25) Filing Language: English
- (26) Publication Language: English
- (30) Priority Data:
10/921,064 18 August 2004 (18.08.2004) US
- (71) Applicant (for all designated States except US): **FMC TECHNOLOGIES, INC.** [US/US]; 200 East Randolph Drive, Chicago, IL 60601 (US).
- (72) Inventors; and
- (75) Inventors/Applicants (for US only): **SUTER, Michael, L.** [US/US]; 5510 Highlands Vista Circle, Lakeland, Florida 33813 (US). **SOCHA, Kevin, G.** [US/US]; 10228 Douglas Oaks Circle, Apt. 101, Tampa, FL 33610 (US).
- (74) Agents: **REGAN, Christopher, F.** et al.; Allen, Dyer, Doppelt, Milbrath & Gilchrist, P.A., 255 S Orange Avenue, Suite 1401, Orlando, FL 32801 (US).
- (81) Designated States (unless otherwise indicated, for every kind of national protection available): AE, AG, AL, AM, AT, AU, AZ, BA, BB, BG, BR, BW, BY, BZ, CA, CH, CN, CO, CR, CU, CZ, DE, DK, DM, DZ, EC, EE, EG, ES, FI, GB, GD, GE, GH, GM, HR, HU, ID, IL, IN, IS, JP, KE, KG, KM, KP, KR, KZ, LC, LK, LR, LS, LT, LU, LV, MA, MD, MG, MK, MN, MW, MX, MZ, NA, NG, NI, NO, NZ, OM, PG, PH, PL, PT, RO, RU, SC, SD, SE, SG, SK, SL, SM, SY, TJ, TM, TN, TR, TT, TZ, UA, UG, US, UZ, VC, VN, YU, ZA, ZM, ZW.
- (84) Designated States (unless otherwise indicated, for every kind of regional protection available): ARIPO (BW, GH, GM, KE, LS, MW, MZ, NA, SD, SL, SZ, TZ, UG, ZM, ZW), Eurasian (AM, AZ, BY, KG, KZ, MD, RU, TJ, TM), European (AT, BE, BG, CH, CY, CZ, DE, DK, EE, ES, FI, FR, GB, GR, HU, IE, IS, IT, LT, LU, LV, MC, NL, PL, PT, RO, SE, SI, SK, TR), OAPI (BF, BJ, CF, CG, CI, CM, GA, GN, GQ, GW, ML, MR, NE, SN, TD, TG).

[Continued on next page]

(54) Title: MULTI-LANE FRUIT GUIDE ASSEMBLY FOR A JUICE EXTRACTOR AND RELATED METHODS

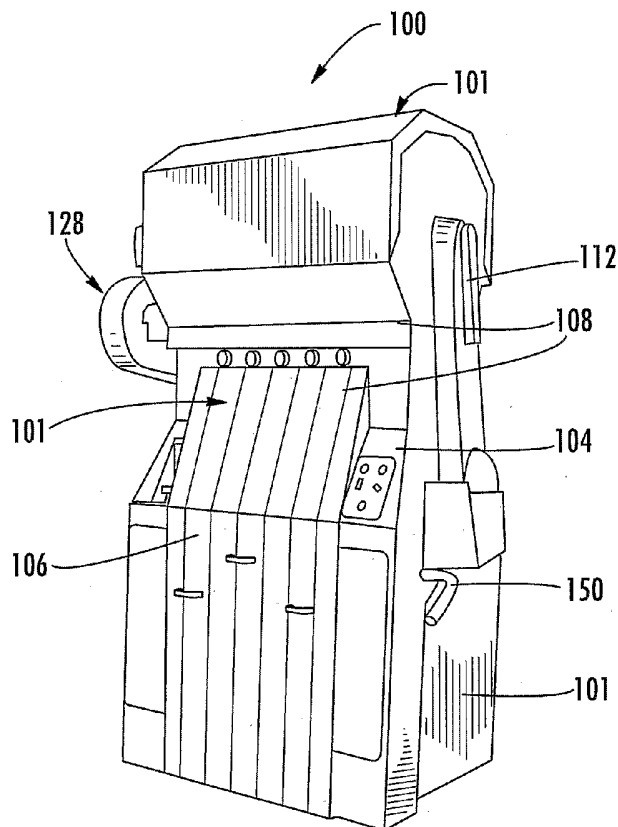

(57) Abstract: A fruit guide assembly may include a frame to be positioned between a fruit conveyor and a multi-position fruit feeder, a vibrator removably fastened to the frame to be removable therefrom in the upward direction, and a fruit guide body removably fastened to the frame to be removable therefrom in an upward direction. The fruit guide body may have an upper surface with alternating ridges and valleys therein defining a plurality of fruit lanes. The fruit guide body may include spaced apart upper and bottom walls so that the fruit guide is a hollow fruit guide body in some embodiments. The hollow fruit guide body may comprise rotationally molded polyethylene, for example.

WO 2006/023270 A2

**Declaration under Rule 4.17:**

— *as to applicant's entitlement to apply for and be granted a patent (Rule 4.17(ii)) for the following designations AE, AG, AL, AM, AT, AU, AZ, BA, BB, BG, BR, BW, BY, BZ, CA, CH, CN, CO, CR, CU, CZ, DE, DK, DM, DZ, EC, EE, EG, ES, FI, GB, GD, GE, GH, GM, HR, HU, ID, IL, IN, IS, JP, KE, KG, KM, KP, KR, KZ, LC, LK, LR, LS, LT, LU, LV, MA, MD, MG, MK, MN, MW, MX, MZ, NA, NG, NI, NO, NZ, OM, PG, PH, PL, PT, RO, RU, SC, SD, SE, SG, SK, SL, SM, SY, TJ, TM, TN, TR, TT, TZ, UA, UG, UZ, VC, VN, YU, ZA, ZM, ZW, ARIPO patent (BW, GH, GM, KE, LS, MW, MZ, NA, SD, SL, SZ, TZ, UG, ZM, ZW), Eurasian patent (AM, AZ, BY, KG, KZ, MD, RU, TJ, TM), European*

patent (AT, BE, BG, CH, CY, CZ, DE, DK, EE, ES, FI, FR, GB, GR, HU, IE, IS, IT, LT, LU, LV, MC, NL, PL, PT, RO, SE, SI, SK, TR), OAPI patent (BF, BJ, CF, CG, CI, CM, GA, GN, GQ, GW, ML, MR, NE, SN, TD, TG)

Published:

— *without international search report and to be republished upon receipt of that report*

For two-letter codes and other abbreviations, refer to the "Guidance Notes on Codes and Abbreviations" appearing at the beginning of each regular issue of the PCT Gazette.

**MULTI-LANE FRUIT GUIDE ASSEMBLY FOR A
JUICE EXTRACTOR AND RELATED METHODS**

Field of the Invention

[0001] The present invention relates to the field of juice extraction, and, more particularly, to fruit feeding for juice extraction.

Background of the Invention

[0002] Citrus juice extraction on a commercial scale can be advantageously performed with a juice extractor including upper and lower cups that move relative to one another along a reciprocal path of travel. The sides of both the upper and lower cups typically comprise fingers that support a fruit so that it can be squeezed without bursting. The fingers of the upper cup interdigitate or intermesh with those of the lower cup.

[0003] An orange or other fruit can be fed, for example, to the bottom cup by a cam-operated feeding device. The upper and lower cups are then brought together so that the respective fingers of the cup intermesh and the fruit therebetween is accordingly squeezed. Sharp, typically circular, cutters are positioned in the top and bottom cups. As the cups move relative to one another, the fruit is pressed against the cutters. The cutters cut plugs from both the top and bottom portions of the fruit as the interdigitating fingers of the two cups mesh together.

[0004] The cutting of the plug from the top portion of the fruit promotes separation of the peel from the

internal portions of the fruit (i.e., juice and pulp). The plug cut from the lower portion of the fruit allows the internal portions of the fruit to be forced down into a strainer tube positioned just below the lower cup cutter. The strainer tube, in turn, is positioned within a manifold.

[0005] Such whole fruit juice extraction is disclosed in commonly assigned U.S. Patent Nos. 5,970,861; 5,992,311; 5,996,485; and 6,568,319, for example, the disclosures of which are hereby incorporated by reference in their entirety. Moreover, various fruit feeding arrangements have been developed for juice extractors. For example, U.S. Patent Nos. 3,040,864; 3,367,473; 3,499,519; 4,309,944 and 4,343,393 disclose such fruit feeding arrangements.

[0006] A typical fruit feeder includes a fruit guide assembly to guide fruit from a fruit conveyor to a multi-position fruit feeder for a fruit juice extractor. For example, the fruit guide assembly may comprise a frame to be positioned between the fruit conveyor and the multi-position fruit feeder, a vibrator removably fastened to the underside of the frame, and a fruit guide body removably fastened to the top of the frame and having an upper surface with alternating ridges and valleys therein defining a plurality of fruit lanes.

[0007] Unfortunately, access to the vibrator motor is relatively difficult with this configuration. Also, the fruit guide body was supported at only its sides or flanges, thereby resulting in cracking at these areas. A two-piece solid plastic guide body and a one piece solid fiberglass guide body have been used in the past.

Summary of the Invention

[0008] In view of the foregoing background, it is therefore an object of the present invention to provide a fruit guide assembly that efficiently guides fruit, and that is more readily serviced and more durable in operation.

[0009] This and other objects, features and advantages in accordance with the invention are provided by a fruit guide assembly including a frame to be positioned between a fruit conveyor and a multi-position fruit feeder, a vibrator removably fastened to the frame to be removable therefrom in the upward direction, and a fruit guide body removably fastened to the frame to be removable therefrom in an upward direction. The fruit guide body may have an upper surface with alternating ridges and valleys therein defining a plurality of fruit lanes. Because the fruit guide body and vibrator are removable in the upward direction, maintenance of the vibrator is greatly enhanced.

[0010] Another advantageous feature of the invention relates to durability. The fruit guide body may have a plurality of fastener receiving passageways therein at side and medial positions. A respective fastener may extend through each fastener receiving passageway to fasten the fruit guide body to the frame at the side and medial positions. This arrangement may provide greater durability as compared to prior mounting arrangements where the fruit guide body was carried by its opposing sides only.

[0011] The frame may comprise a base plate having an opening in a medial portion thereof. In these embodiments, the vibrator at least partially extends through the opening in the base plate. The frame may

further comprise a pair of mounting ears connected to opposite sides of the base plate, and vibration dampeners and associated fasteners may be connected to the pair of mounting ears. A mounting flange may be connected between the vibrator and the base plate.

[0012] Other aspects and advantages relate to the fruit guide body. For example, the fruit guide body may include spaced apart upper and bottom walls so that the fruit guide is a hollow fruit guide body in some embodiments. More particularly, the hollow fruit guide body may comprise rotationally molded polyethylene, for example. This provides a durable, yet relatively lightweight fruit guide body that may require less vibrational energy.

[0013] A method aspect of the invention is for making a fruit guide assembly to guide fruit from a fruit conveyor to a multi-position fruit feeder for a fruit juice extractor. The method may include removably fastening a vibrator to a frame to be positioned between the fruit conveyor and the multi-position fruit feeder so that the vibrator is removable in an upward direction; and removably fastening a fruit guide body to the frame and comprising a bottom wall and an upper wall spaced therefrom so that the fruit guide body is removable in the upward direction, the upper wall having a series of alternating ridges and valleys therein defining a plurality of fruit lanes.

[0014] Another method aspect of the invention is for making a fruit guide body for a fruit guide assembly to guide fruit from a fruit conveyor to a multi-position fruit feeder for a fruit juice extractor. The method may include molding the fruit guide body from a moldable material to have a bottom wall and an upper wall spaced therefrom so that the fruit guide is a

hollow fruit guide body with the upper wall having a series of alternating ridges and valleys therein defining a plurality of fruit lanes. For example, the molding may comprise rotationally molding.

Brief Description of the Drawings

[0015] Other objects, features and advantages of the present invention will become apparent from the detailed description of the invention which follows, when considered in light of the accompanying drawings in which:

[0016] FIG. 1 is a rear perspective view of the juice extractor of the present invention and showing in detail the integral electrical panels.

[0017] FIGS. 2 and 3 are overall schematic, perspective views of a juice extraction process, showing three juice extractors in FIG. 3, each having five individual juice extractor positions defined by juice extractor units, each comprising a moveable and a fixed extractor cup, a strainer tube, extractor cup, and an orifice tube that is reciprocated within each strainer tube.

[0018] FIG. 4 is a partial perspective and fragmentary view of a portion of a juice extractor unit showing a moveable and a fixed extractor cup, a strainer tube, an orifice tube received within the strainer tube, a cup bridge, and a juice manifold.

[0019] FIG. 5 is a perspective view of a juice extractor of the present invention showing an improved exterior design with integral electrical panels, ribbed covers, and the improved multi-lane feeder table formed as a hollow fruit guide body.

[0020] FIG. 6 is an enlarged rear perspective view of the juice extractor similar to FIG. 1, but looking

from a different angle toward the rear of the extractor.

[0021] FIG. 7 is a perspective view similar to FIG. 6, but having the outer covers of the juice extractor removed and showing in detail the integrated cup bridge and juice manifold supporting the fixed extractor cups, the moveable extractor cups mounted on a moveable cup beam, inner wall members that define a drive mechanism cavity, and the orifice beam with its ends extending through a window opening into the drive mechanism cavity.

[0022] FIG. 8 is an exploded, perspective view of the fruit guide assembly of the present invention and showing an insertable hollow fruit guide body forming a feeder table and a top loading vibrator.

[0023] FIG. 9 is an enlarged perspective view of the hollow fruit guide body of the present invention.

[0024] FIG. 10 is an enlarged perspective view of a portion of the fruit guide body showing fastener supports.

[0025] FIG. 11 is a bottom perspective view of the fruit guide body shown in FIG. 9 and showing structural supports as stiffening features.

[0026] FIG. 12 is a front elevation and partial fragmentary view of the multi-position fruit feeder of the present invention showing a drive shaft, a plurality of fruit feed members, the load sensitive coupler, and decoupling detector.

[0027] FIG. 13 is a perspective view of the fruit feeder and showing the use of a proximity switch in accordance with the present invention.

[0028] FIG. 14 is a fragmentary, partial perspective view of the camshaft for the juice extractor and showing in detail the cup drive cams for the moveable

extractor cups, the return cams, orifice beam drive cams, and counterweights mounted on the camshaft.

[0029] FIG. 15 is another isometric and partial fragmentary view of the camshaft of the present invention and showing the upper main and cam follower train used for the return cam.

[0030] FIG. 16 is a fragmentary, perspective view of a counterweight mounted on the drive gear contained within the gearbox.

[0031] FIGS. 17 and 18 are sectional views showing a shaft-hub coupler frictionally securing together the camshaft and hub of the cams, with FIG. 17 showing a countersunk flange, and FIG. 18 showing a flange outside the hub bore.

[0032] FIG. 19 is a perspective view of the integrated cup bridge and juice manifold and showing juice outlets positioned at the side, and fluid outlets formed on the top of the cup bridge for receiving pressure-actuated spray nozzles of the present invention.

[0033] FIG. 20 is a fragmentary, perspective view of the integrated cup bridge and juice manifold shown in FIG. 19, including a strainer tube support cone mounted to aid in supporting strainer tubes.

[0034] FIG. 21 is a bottom perspective view of the integrated cup bridge and juice manifold of FIG. 19.

[0035] FIG. 22 is a front elevation view of the integrated cup bridge and juice manifold shown in FIG. 19, but with the added strainer tube support cones.

[0036] FIG. 23 is a sectional view taken along line 23-23 of FIG. 22.

[0037] FIG. 24 is a fragmentary, perspective view of the integrated cup bridge and juice manifold of the present invention and showing the bottom loaded

strainer tube and sealing assembly for sealing the strainer tube to the juice manifold.

[0038] FIG. 25 is an enlarged, sectional view of the lower end of the strainer tube shown in FIG. 24 and showing greater details of the sealing assembly between the strainer tube and juice manifold.

[0039] FIG. 26 is a perspective view of the orifice beam used in the present invention with ends adapted to extend through beam openings within inner side panels of the juice extractor.

[0040] FIG. 27 is a fragmentary, front elevation view of a portion of the juice extractor showing basic components of the juice extractor, including the orifice beam mounted for movement with the extractor frame and tapered spray nozzles on the inner side panels, in accordance with the present invention.

[0041] FIGS. 28 and 29 are perspective views of the pressure actuated spray nozzle used in the present invention.

[0042] FIG. 30 is a fragmentary, sectional and perspective view of the spray nozzle shown in FIGS. 28 and 29.

[0043] FIG. 31 is a top plan view of the spray nozzle shown in FIGS. 28 and 29.

[0044] FIG. 32 is a sectional view of the spray nozzle taken along line 32-32 of FIG. 31.

[0045] FIG. 33 is an enlarged, perspective view of a portion of the integrated cup bridge and juice manifold showing two pressure actuated spray nozzles of the present invention mounted thereon.

[0046] FIGS. 34 and 35 are perspective views of the nozzle body, i.e., the spray nozzle head shown in FIGS. 30 and 32.

[0047] FIGS. 36 and 37 are respective side and front elevation views of the nozzle body shown in FIGS. 34 and 35.

[0048] FIGS. 38 and 39 are perspective views of the lower portions of the nozzle body, i.e., the nozzle lower pintle shown in FIGS. 30 and 32.

[0049] FIG. 40 is a top plan view of the lower nozzle body section shown in FIGS. 38 and 39.

[0050] FIG. 41 is an elevation view of the lower nozzle body section shown in FIGS. 38 and 39.

[0051] FIGS. 42 and 43 are perspective views of the tubular housing that receives the nozzle body as shown in FIGS. 30 and 32.

[0052] FIG. 44 is a side elevation view of the tubular housing shown in FIGS. 42 and 43.

[0053] FIG. 45 is a sectional view taken along line 45-45 of FIG. 44.

[0054] FIG. 46 is a partial sectional and perspective view of the tapered spray nozzle of the present invention adapted to be mounted flush on a wall at a fluid outlet within the juice extractor.

[0055] FIG. 47 is a perspective view of the spray nozzle head shown in FIG. 46.

[0056] FIG. 48 is a perspective view of the tapered spray nozzle of the present invention.

[0057] FIG. 49 is a sectional view of the tapered spray nozzle of the present invention showing basic components.

[0058] FIG. 50 is a top plan view of the spray nozzle head.

[0059] FIG. 51 is a sectional view of the nozzle fastening body shown in FIGS. 46 and 49.

[0060] FIG. 52 is a front perspective view of the nozzle fastening body.

[0061] FIG. 53 is a perspective view of the nozzle retaining ring of the present invention shown in FIGS. 46 and 49 that secures the spray nozzle head to the nozzle fastening body.

[0062] FIG. 54 is a sectional view of the nozzle retaining ring shown in FIG. 53.

Detailed Description of the Preferred Embodiments

[0063] The present invention will now be described more fully hereinafter with reference to the accompanying drawings, in which preferred embodiments of the invention are shown. This invention may, however, be embodied in many different forms and should not be construed as limited to the embodiments set forth herein. Rather, these embodiments are provided so that this disclosure will be thorough and complete, and will fully convey the scope of the invention to those skilled in the art. Like numbers refer to like elements throughout, and prime notation is used to indicate similar elements in alternative embodiments.

[0064] The present invention provides many advantages over prior art juice extractors, such as disclosed in commonly assigned U.S. Patent Nos. 2,649,730; 2,780,988; 3,717,084; 3,736,865; 4,300,449; 4,309,943; 4,309,944; 4,376,409; 4,700,620; 4,905,586; 4,922,813; 5,339,729; 5,483,870; 5,970,861; 5,992,311; 5,996,485; and 6,568,319, the disclosures which are hereby incorporated by reference in their entirety.

[0065] The present invention includes a new exterior design of the juice extractor, including the exterior outer cover over the extractor frame. The enhanced design includes integrated electrical panels and ribbed outer covers as shown in FIG. 1 and explained in greater detail below. The overall juice extractor design has a slope formed by the outer covers on the

extractor frame columns. The present invention also provides a fruit guide assembly including a hollow fruit guide body forming a multi-lane feeder table, also known as a feed hopper, which receives fruit from the feed belt adjacent the extractor line and delivers fruit to a multi-position fruit feeder. The present invention facilitates faster changing of the fruit guide body forming a feeder table, a feed hopper, and eliminates the requirement to remove the vibrator with the feeder table. In the present invention, the fruit guide body bolts to a separate support frame and is easily removable. The vibrator can be removable from the top as an additional service and safety feature. The present invention also eliminates the deadhead previously used with a feeder table.

[0066] A multi-position fruit feeder of the present invention uses a proximity switch to detect movement of a load sensitive coupler that incorporates a shear pin. If the shear pin breaks, the load sensitive coupler no longer rotates and the proximity sensor detects this change. This is advantageous over other prior art juice extractors, which continued running when foreign material jammed the fruit feeder, breaking the shear pin. The proximity sensor can be attached to a timer. When the juice extractor is in operation, the sensor detects movement and produces respective ON/OFF pulses. If, after a predetermined period of time, the pulses are no longer detected, for example, when the shear pin is broken, the juice extractor will automatically shut down.

[0067] The juice extractor of the present invention also advantageously incorporates a return cam, typically formed as a mathematical conjugate of the extractor cup drive cam to hold the cam followers to

the cam and lift the cup support member, i.e., cup beam, during the juice extraction cycle. A counterweight can be mounted to the main drive gear located within the gearbox, or mounted on the camshaft that supports the drive cam and return cam. The counterweight provides balance to the machine during extractor operation.

[0068] The juice extractor of the present invention also has inner side panels that define a medial product material area, i.e., a juice and peel area, where the fixed and moveable extractor cups are located, and opposing drive mechanism cavities located between the inner side panels and outer covers of the extractor frame. Peel, of course, includes pulp, seeds, membranes, and core materials. Drive linkages such as a pull-rod assembly, are positioned in each drive mechanism cavity and operatively connect the orifice beam with the orifice beam drive cam mounted on the camshaft. A tapered water spray nozzle of the present invention can be mounted flush on the inner side panels to spray cleaning fluid to aid in cleaning. To enhance cleaning of the juice extractor, the present invention includes a cup bridge formed integral with the juice manifold. Juice piping extends from the juice outlet at the side and exit through the side of the juice extractor, thus eliminating a current piping arrangement where "bullhorn" pipes extend out the front or rear and allow debris build-up. The integrated cup bridge and juice manifold typically has juice outlets at the side juxtaposed to the inner wall panels, which allows the juice piping to exit the sides.

[0069] The strainer tube is preferably bottom loaded, and includes an improved sealing assembly between the juice manifold and strainer tube. The

camshafts are now preferably held by friction on the camshaft through an appropriate cup-drive, shaft-coupler frictionally securing the camshaft in the cam hub. Alignment of the cams can be arranged by positioning an alignment rod through holes placed in the cams during assembly.

[0070] The integrated cup bridge and juice manifold includes a number of pressure actuated spray nozzles, i.e., also referred to as pop-up nozzles, mounted on the integrated cup bridge and juice manifold (FIGS. 28-45). These pop-up nozzles can be used for both oil recovery and cleaning. In the present invention, the ends of the orifice beam extend through each inner wall or "side" panel into the drive mechanism cavity where the orifice beam drive mechanism is located. This penetration through the inner wall panels is protected by a moving "window" between the ends of the orifice beam and the side wall panel and formed as a preferred labyrinth seal.

[0071] It is clear that the present invention provides numerous advantages over the prior art juice extractors as will be explained in greater detail below with reference to the accompanying drawings.

[0072] For purposes of facilitating operation of the juice extractor of the present invention, a general description of the overall juice extraction process from fruit unloading to final processing and waste handling is described with reference to FIGS. 2 and 3. FIG. 4 is an environmental, partial isometric and sectional view of a portion of a single juice extractor unit, which would be positioned in a respective juice extractor machine 40 shown in FIG. 3 and forming respective juice extractor positions where fruit is compressed and juice extracted. The description will

proceed by first describing an overall flow of citrus fruit, followed by an explanation of various component parts of a juice extractor unit relative to the overall juice extractor machine, thus giving a general working background of juice extractor principles used in the present invention.

[0073] As shown in FIG. 2, fruit F can be unloaded by manual, hydraulic, or truck unloading. For example, fruit can be unloaded manually by workers handling many field boxes or cartons, which can be set on a dump ledge **20** for unloading into a hopper **22**. Additionally, citrus fruit could be dumped into the hopper **22** by means of an automatic hydraulic dump **23**. A large load carrying citrus fruit F, such as oranges, could also arrive by truck, which would dump the fruit into the hopper **22**, which includes a vertical conveyor belt **24** that carries fruit F on the necessary conveyors to a brush washer **26**. Typically, the conveyor belt **24** has about three inch cleats to elevate fruit to the brush washer **26**, as known to those skilled in the art. As the fruit is unloaded, the fruit enters a washer and passes under spray nozzles **28**, where fruit cleaners can be applied.

[0074] The fruit, as it is washed, passes over a series of brushes in the brush washer **26**, where the fruit is gently scrubbed to remove field oils, soil, mold and dust. The brush washer **26** discharges the fruit onto a roller grader **30** where workers can easily select the fruit. Typically, the roller grader **30** is formed such that workers can stand on either side and remove any broken pieces, leaves and other undesirable materials from the flow of fruit supply. It is at this point that some foreign material can still pass through the roller grader. Foreign material, such as milkweed

pods, is one example that workers often miss. These milkweed pods are indigenous to citrus growing areas and can cause problems during the juice extraction process. The juice extractor is preferably designed to shut down when the orifice tube becomes lodged within the strainer tube, such as by foreign material, and it allows the juice extractor to shut down operation if a milkweed pod or other similar foreign material becomes stuck in the orifice tube.

[0075] The fruit discharges from the roller grader into a cleated belt conveyor **32** that elevates the fruit typically by three inch cleats to the tilted feed belt conveyor **34**, as shown in FIG. 3. If two or more juice extractors are placed in tandem as illustrated, a sizing roller **36** provides a single, continuously rotating roller on the tilted feed belt conveyor **34** to separate the fruit into sizes equivalent to the size range of the moveable and fixed extractor cups to ensure maximum yield and quality. For example, as illustrated with the three juice extractors **40**, one juice extractor can be used for one range of fruit size, and the other two juice extractors can be used for respective two other ranges of fruit sizes.

[0076] As shown in FIG. 3, each juice extractor **40** includes individual juice extractor units **50** (illustrated as five units) that are ganged together in a common extractor frame **52** forming a juice extractor machine **40**. The juice extractor unit **50** defines respective juice extractor positions where an individual fruit is received on a fixed extractor cup and compressed or squeezed by a respective moveable extractor cup. The fixed and moveable extractor cups can be horizontally aligned or aligned vertically as explained with reference to the drawings. With

vertically aligned extractor cups as illustrated, the fixed extractor cup is typically a lower extractor cup and the moveable extractor cup is typically an upper extractor cup.

[0077] The fruit is moved to the feed hoppers **46**, i.e., multi-lane feeder table **46** of the juice extractors **40** by a feed belt conveyor **34** that is designed at an angle of about 18° with the low side adjacent to the feeder table **46**. The feeder table **46** is formed as a fruit guide assembly that guides fruit from the fruit conveyor to a multi-position fruit feeder as will be explained in detail below. Any fruit that passes by the feeder table is recirculated through a fruit handling system by a return fruit conveyor **48**. This fruit could be transferred back to the fruit handling system prior to washing.

[0078] The fruit enters the juice extractor feed table **46** and is fed into the fixed, e.g., lower extractor cup **54** by fruit flipper fingers (not shown) operable as part of the multi-position fruit feeder. As will be explained later in detail, the fruit is separated into three primary product streams, a pulpy juice, the peel, and the fruit material that enters an orifice tube **56** (FIG. 4). The waste peel is directed onto a peel screw **58** located under the juice extractor platform **60** and is discharged into a discharge hopper **62** or other waste disposal container, or it can be conveyed through an exterior wall to a truck or trailer, or to further processing.

[0079] Typically, the juice extractors **40** are supported on an elevated platform **60** not only to provide support for the juice extractors, but also to provide access for mechanical operation and maintenance. The juice from the various juice

extractors **40** enters a stainless steel discharge header **64** extending from each juice extractor and is gravity fed into a surge tank **66** that is designed to maintain a constant flow of juice, preferably to an optional finisher **68**. The finisher further removes pulp from the juice by using stainless steel screens with small perforations. A finisher **68** typically is used when a number of juice extractors are placed in tandem, as illustrated.

[0080] The juice can be pumped from the surge tank **66** or finisher **68**. The juice extraction process shown in FIGS. 2 and 3 is illustrative of a small juice extraction facility. Larger juice extraction facilities are similar in process, but are larger in scale and may include additional equipment known to those skilled in the art. Additional equipment (not shown) may include bucket elevators for lifting and conveying fruit; fruit storage bins for temporary storage of unloaded fruit; sizing equipment for sorting fruit based on size; byproduct recovery systems such as pulpwash systems, and oil recovery systems; feedmills for drying of peel waste; and pasteurizers and evaporators for the processing of juice. These and other equipment are known to those skilled in the art.

[0081] Referring to FIG. 4, a portion of a basic juice extractor unit **50** defining a juice extracting position of a juice extractor is illustrated. A moveable extractor cup **80** is mounted on a common cross bar, i.e., a cup support member, also referred to as the cup beam **82** in the illustrated embodiment. The cup beam **82** interconnects other moveable extractor cups as shown in FIG. 3. The cup beam **82** reciprocates by a cam drive (not shown) contained in an upper portion of a juice extractor in this non-limiting embodiment. The

fixed extractor cups **54**, e.g., lower extractor cups in the illustrated embodiment, are rigidly positioned relative to the extractor frame **52** and mounted on a cup bridge **57**. The moveable and fixed extractor cups **80,54** are formed as interdigitated extractor cups that have fingers **84** that intermesh together when the moveable extractor cup **80** engages fixed extractor cup **54**.

[0082] The moveable and fixed extractor cups **80,54** and their associated components, such as the prefinisher strainer tube **86**, the orifice tube **56**, and associated cup bridge **57**, form one juice extractor unit **50**. As illustrated in FIG. 3, a number of juice extractor units are ganged together in one juice extractor machine **40** to increase production. The illustrated juice extractor machine **40** includes five juice extractor units **50** positioned at respective juice extracting positions. The fruit feeder, which will be explained in greater detail below, also can work as a cam-operated device, and includes feeding fingers (not shown in this figure), which deposit a single fruit in the fixed extractor cup **54**, such as by tossing the fruit into the extractor cup after receiving the fruit from the feeder table formed as a fruit guide assembly.

[0083] The cam-operated drive system in the upper part of the juice extractor forces the moveable extractor cup **80** into the fixed extractor cup and as this occurs, the fruit **F** is pressed against a circular cutter **90** located at the top of the prefinishing strainer tube **86**. This cutter **90** cuts a plug in the bottom of the fruit to allow the internal portions of the fruit access to the strainer tube **86**. Another cutter **92** also cuts a plug in the top of the fruit to permit separation of the peel from the internal portions of the fruit, such as the pulp. As the

fingers **84** of the extractor cups **54, 80** interdigitate or mesh together, the inner portion of the fruit, such as the pulpy juice, is forced down into the strainer tube **86** contained within the juice manifold **94**. The peel surfaces do not contact the juice and any contamination by the extractives in the peel is minimized. The peel falls away outside the juice manifold **94** and can be collected by the peel screw conveyor **58** under the extractor platform **60** and discharged into the hopper **62** or other waste disposal container and conveyed through an exterior wall to a truck or trailer or to further processing.

[0084] The continuing stroke of the moveable extractor cup **80** and the presence of a restrictor, for example, in the form of blockages, force the juice-bearing portion of the fruit through the perforated wall of the strainer tube. This perforated wall is formed by small strainer tube holes **98**, which allow discharge of juice into the juice manifold **94**.

[0085] Back pressure is preferably applied into the orifice tube, for example, by a hydraulic device as described in the incorporated by reference 5,992,311 patent or by limiting the size of the size of the restrictor. The orifice tube reciprocates within the strainer tube to compress any entrapped fruit particles and force any remaining juice through the perforated wall of the strainer tube. Core material, such as section membrane and seeds, are ejected typically from the lower portion of the orifice tube during reciprocating movement of that tube. This cycle of extraction is then complete.

[0086] Additionally, the amount of juice yield and the type of juice can be varied by using different strainer tubes with different size holes **98**.

Additionally, the back pressure can be changed to vary the juice yield and type of juice. Peel oil, such as liberated by the shredding action of the moveable and fixed cups' fingers, typically can be washed by water sprays around the extraction cups.

[0087] Referring now to FIGS. 1, 5, 6 and 7, there are illustrated different views of the juice extractor **100** of the present invention, including a respective front perspective view (FIG. 5), a rear perspective view from a first angle (FIG. 1), an enlarged rear perspective view from a second angle (FIG. 6), and a rear perspective view with outer covers removed (FIG. 7). The juice extractor **100** has an outer wall surface formed by outer covers **101**, which are secured over the extractor frame **102** (FIG. 7). The outer covers **101** are configured to form a new shape of the juice extractor in the side areas and include integrated electrical panels **104** as shown in FIGS. 1 and 6. Ribbed covers **106** and a top slope **108** formed by the outer covers make an aesthetic and ornamental design.

[0088] The front perspective view of FIG. 5 shows a fruit guide assembly of the present invention forming a multi-lane feeder table **110** with an integrated deadhead. This fruit guide assembly **110** as a feeder table is formed as a hollow fruit guide body and is explained in greater detail below with reference to FIGS. 8-11. The feeder table **110** feeds fruit into a fruit feeder (not shown in detail) having fruit flipper fingers that convey fruit into the fixed extractor cups **54** shown in the non-limiting example as lower extractor cups. Details of the fruit feeder are described below relative to FIGS. 12 and 13. The fruit feeder is driven by a feeder drive mechanism, indicated generally at **112**, which extends from a camshaft located in the

upper portion of the juice extractor **100** and connects to the drive (or finger) shaft as will be explained in greater detail below. The improved design of this illustrated juice extractor **100** no longer has an external electrical box, air hose and protruding housing members.

[0089] As illustrated, only a few inlet and outlet fluid pipes are required for fluid intake and discharge, such as water or a cleaning fluid or juice exiting the juice manifold. A cycle of cleaning water can be flushed through the juice extractor, and its timing controlled by the control circuitry **114** shown in FIG. 2. The sloped discharge surface **116** shown in FIG. 5 and positioned under the feeder table **110** extends from an integrated cup bridge and juice manifold (not shown in detail in this figure) and allows misfed fruit to return. Greater details of the integrated cup bridge and juice manifold of the present invention are explained in greater detail below with reference to FIGS. 19-24.

[0090] FIG. 5 illustrates an electrical drive motor **118** supported by the extractor frame **102** and outside the outer cover **101**. The drive motor **118** is enclosed within a protective steel mesh enclosure frame **120**. The drive motor output shaft (not shown) connects to a large drive gear **122**, which is connected by a gear train to an extractor frame mounted camshaft to be explained in greater detail below with reference to FIGS. 14-16.

[0091] FIG. 7 is a rear perspective view of the juice extractor **100** of the present invention with outer covers **101** removed and showing many of the improvements of the present invention, including the drive mechanism **128** for driving moveable extractor cups **80**. The drive

mechanism **128** is mounted in a top section of the extractor and includes a camshaft **130** that supports orifice beam drive cams **132** on the outer ends of the camshaft, but within the confines of the extractor frame **102**. The fixed extractor cups **54** are supported on an integrated cup bridge and juice manifold **134** and receive the moveable extractor cups **80** supported on the cup beam or other moveable cup support member **82** and reciprocated into engagement with the fixed extractor cups. Two drive cams **136** each engage a cam follower (not shown) for driving the cup beam **82**, allowing the moveable, e.g., upper extractor cups **80**, to engage the fixed, e.g., lower extractor cups **54** supported by the integrated cup bridge and juice manifold **134** of the present invention. A return cam is not shown in this figure, but is explained relative to FIGS. 14 and 15, and is used for returning the cup beam into a disengaged (e.g., raised) position, thus disengaging the moveable extractor cups **80** from the fixed extractor cups **59**. It should be understood, however, that the extractor cups can be arranged horizontally or in another orientation besides a vertically opposed relationship.

[0092] An orifice beam **140** supports the orifice tubes **56**, which are received within respective strainer tubes **86**. The orifice beam **140** reciprocates, moving the orifice tubes **56** within the strainer tubes **86**, which are supported by the integrated cup bridge and juice manifold **134**. As shown in FIG. 7, at least one outer end **140a** of the orifice beam **140** extends through an inner side panel **142** into a drive mechanism cavity **144** formed between the inner side panel **142** and an outer cover **101** over the extractor frame **102** of the juice extractor **100**. In a preferred embodiment, two

opposing inner side panels **142** define a medial product material area **143**, i.e., a "juice and peel" area where extractor cups are located. Opposing drive mechanism cavities are defined at either side of the juice extractor.

[0093] An appropriate drive mechanism, for example, a pull rod assembly or other drive assembly, is positioned within each drive mechanism cavity **144** and connected between the orifice beam end **144a** and a cam follower mechanism that engages the orifice beam drive cam **132**, shown in greater detail in FIGS. 14, 16 and 27. As the driven camshaft **130** rotates, the orifice beam drive cam **132** rotates, presses against a cam follower mechanism and associated pull-rod assembly or other drive assembly, and forces downward the orifice beam **140**. A return spring mechanism (not shown) pulls upward on the orifice beam **140** through its pull-rod assembly, returning the orifice beam **140** to its initial position and forcing the orifice tube into the strainer tube for the juice extraction process.

[0094] To aid in cleanability of the juice extractor of the present invention, the integrated cup bridge and juice manifold **134** has its juice outlets juxtaposed at the inner side panels **142**. Juice piping **150** connects to the juice outlets and extends out the side of the juice extractor as illustrated in FIGS. 7 and 27. The integrated cup bridge and juice manifold **134** are explained in greater detail relative to FIGS. 19-23.

[0095] The ends **140a** of the orifice beam **140** are moveable within an access window **152** formed as window openings, i.e., a slot, in the inner side panels **142**. A seal, and preferably a labyrinth seal **154**, is positioned at the orifice beam end **140a** and inner side panel **142** to form a moving "window." The seal **154**

prevents debris from passing from the product material, i.e., "juice and peel" area **143** within the juice extractor **100** and into the drive mechanism cavity **144**.

[0096] Any small amount of debris that passes through this seal **154** can be washed from the drive mechanism cavity **144** by one or more spray nozzles of the present invention that are positioned in the juice extractor, on side walls, including the inner side panel, and even in the drive mechanism cavity, which is explained in greater detail relative to FIG. 27 and FIGS. 46-54. Fluid that is sprayed into the juice extractor product material area **143** and even the drive mechanism cavity **144** can drain back toward the interior sections of the juice extractor machine, which is self-draining. Cleaning fluid and recycle fluid used for oil recovery can be discharged through appropriate fluid delivery conduits.

[0097] FIG. 8 shows an exploded isometric view of the insertable multi-lane feeder table **110**, or fruit guide assembly as it is also referred, and the top loading vibrator of the present invention. Throughout this description, the term feeder table can be used interchangeably for fruit guide assembly when describing the present invention.

[0098] Referring now to FIGS. 8-11, the fruit guide assembly **110** of the present invention forms a feeder table and guides fruit from the fruit conveyor **34**, such as shown in FIGS. 2 and 3, to a multi-position fruit feeder explained in greater detail relative to the description of FIGS. 12 and 13. The fruit guide assembly **110** includes a frame **158** that is positioned between the fruit conveyor **34** and the multi-positioned fruit feeder. A vibrator **160** is connected to the frame **150**. The fruit guide assembly includes a hollow fruit

guide body **162** that includes a bottom wall **164** and an upper wall **166** spaced therefrom. The upper wall **166** has a series of alternating ridges **168** and valleys **170** that define a plurality of fruit lanes **172**. Each pair of adjacent ridges **168** extend outwardly beyond an end of an intervening valley **170** to define an opening **174** to permit passage therethrough of a corresponding portion of the multi-positioned fruit feeder and to define integrally formed cantilevered ridge ends **176** for supporting the fruit. Thus, it is evident that the present invention eliminates the deadhead that had been a separate part of a feeder table of prior art juice extractors in which a vibrator or other assembly vibrated a table, while the deadhead remained "static" or "dead" to slow vibration and enhance fruit feeding into fixed extractor cups **54**.

[0099] This hollow fruit guide body **162** has a plurality of fastener receiving passageways **178** at both side and medial positions. A respective fastener **180** extends through each fastener receiving passageway **178** and fastens the hollow fruit guide body **162** to the frame **158** at the side and medial portions of the body **162**. The fruit guide body **162** is removably fastened to the frame **158** and removable therefrom in an upward direction. The vibrator **160** is removably fastened to the frame to be removable in an upward direction.

[00100] In one aspect of the present invention, the frame **158** includes a base plate **182** and having an opening **184** in a medial portion. The vibrator extends at least partially through the opening **184** in the base plate **182** and is secured to a vibrator mounting plate **186** that secures to the base plate **182** over the opening **184**. A pair of mounting ears **188** are formed at opposite sides of the base plate **182**. A pair of

brackets **190** are mounted to the frame **52** of the fruit juice extractor **100**. A plurality of vibration dampeners **192** and associated fasteners **194** connect the pair of brackets **190** to the pair of mounting ears **188**. The mounting plate **186** acts as a flange and is connected between the vibrator **160** and the base plate **182**.

[00101] The hollow fruit guide body **162** preferably is formed from a polymer, such as rotationally molded polyethylene, but other plastic materials can be used as suggested by those skilled in the art. The bottom wall, as shown in FIG. 11, has stiffening features **196** adding strength to the structure, which can be formed during the molding process.

[00102] It is evident that the present invention now provides a feeder table, i.e., formed as a fruit guide assembly **110**, which not only includes an easily removable fruit guide body, but also includes an easily removable vibrator **160**, which saves on maintenance time and costs throughout the operational life of the juice extractor.

[00103] The present invention also provides a multi-position fruit feeder that uses a proximity switch, in one non-limiting example, to detect movement of a load sensitive coupler having a shear pin that is broken when the fruit feeder is jammed or a similar problem occurs. If the shear pin breaks, the load sensitive coupler no longer rotates, and a proximity sensor, for example, detects this change. A processor, for example, a programmable logic controller (PLC) or other mechanism, can automatically stop the juice extractor when the lack of rotation is detected. This is advantageous over prior art juice extractors, which continued running when foreign material jammed a fruit

feeder, breaking the shear pin. In one aspect of the present invention, the proximity sensor can be attached to a timer. When the juice extractor is in operation, the proximity sensor detects movement and produces respective on/off pulses. If, after a predetermined period of time, the pulses are no longer detected, for example, when a shear pin is broken and rotation stopped, the juice extractor automatically shuts-down.

[00104] FIGS. 12 and 13 illustrate the improved fruit feeder **200** for feeding fruit into the juice extracting positions defined by each juice extractor unit **50** and defined by the fixed and moveable extractor cups **54,80**. The fruit feeder **200** includes a proximity drive shaft **202** and a plurality of fruit feed members **204**, for example, formed as fruit feed fingers for feeding fruit to the juice extracting positions **50** based upon rotation of the drive shaft **202**. A load sensitive coupler **206** couples a drive motor, for example, the electric drive motor **118** via the feeder mechanism drive **112**, to the drive shaft **202** during normal operation, and decouples the drive motor from the drive shaft **202** when the fruit feed members **204** become jammed. A decoupling detector **208** detects decoupling of the load sensitive coupler **206**. In the embodiment shown in FIGS. 12 and 13, the drive motor could be the primary juice extractor drive motor **118** with a transmission linkage or other drive mechanism **112** that interconnects the drive shaft **202** and the electric motor **118** supported by extractor frame **52** and outside the juice extractor outer covers as shown in FIG. 5.

[00105] A drive hub **210** is rotatably carried by the drive shaft **202** and operatively connected to the drive motor **118**. A fixed hub **212** is secured to the drive shaft adjacent the rotatable drive hub **210**. A shear

pin **214** extends between the rotatable drive hub **210** and the fixed hub **212** to couple the rotatable drive hub **210** and the fixed hub **212** together during normal operation, and to shear and decouple the rotatable drive hub **210** from the fixed hub **212** when the fruit feed members **204** become jammed. This decoupling detector **208**, in one aspect of the present invention, is preferably a proximity sensor. Also, at least one proximity sensor trigger **216** is rotatably carried by the drive shaft **202**. When the proximity sensor is positioned adjacent a path of the at least one proximity sensor trigger **216**, a pulse is preferably generated. For example, the proximity sensor trigger could be at least one ferrous fastener, for example, screws that act as the trigger. These screws could be carried by the rotatable drive hub **210**. The proximity sensor can also be connected to a timer. When the juice extractor is running, the proximity sensor detects the movement of the trigger and produces on/off pulses. If, after a predefined period of time, the pulses are no longer detected, the juice extractor will automatically shut down via the controller.

[00106] In one aspect of the present invention, a fruit feed member **204** includes at least one finger shaft **220** and a plurality of fruit flipper fingers **222** carried by the finger shaft. In a preferred aspect of the present invention, three equally spaced finger shafts **220** are used. The central drive shaft **202** is driven, turning a cam assembly (not shown) inside the hub, which rotates, and the three shafts **220** rotate around the center drive shaft **202**, moving the fruit flipper fingers **222** for lifting the fruit and feeding or "tossing" the fruit into a fixed extractor cup **54**.

[00107] In yet another aspect of the present invention, a decoupling detector operates an indicator based upon the detection of decoupling. In one aspect of the present invention, it could include at least one magnetic sensor, an optical sensor, an electrical field sensor, an ultrasonic sensor or an infrared sensor, as non-limiting examples.

[00108] The juice extractor of the present invention also advantageously uses a return cam, typically formed as a mathematical conjugate of the extractor cup drive cam, i.e., cup cam, to hold cam followers to the cams and lift the cup support member, i.e., cup beam, during the juice extraction cycle. This overcomes the disadvantage of having to increase the spring force necessary to hold cam followers tightly to the drive cam or use higher air pressure to prevent "knocking" of the cams corresponding to the separation of any cam from its follower.

[00109] FIGS. 14 and 15 are isometric views of the drive mechanism 128 that engages the moveable extractor cups 80, such as through the moveable cup beam or other moveable cup support member 230, and drives the moveable extractor cups 80 into engagement with the fixed extractor cups 54. This drive mechanism 128 includes the camshaft 130 supporting the drive cam 136 for driving the moveable extractor cup 80 into engagement with the fixed extractor cup 54 and a return cam 232 for disengaging the moveable extractor cup 80 using a cam follower train 234 operatively connected to the return cam 232 for raising the cup beam 230 and disengaging the moveable extractor cup 80 (FIG. 15).

[00110] As illustrated, the camshaft 130 supports two drive cams 136 and two return cams 232 that are spaced from each other, and imparts a driving force onto the

respective cup beam **230** and cam follower train **234**, which operate at appropriate timed intervals as the camshaft is rotated. The cam follower train **234** includes appropriate support frame members **236** that are secured to the extractor frame **52** and guide rods **238**. A cam follower mechanism **240** is slidable on the guide rods **238** and secured to the cup beam **230** or other cup support member. The return cam drives upward the cam follower mechanism **240** on the guide rods **238**, thus pulling upward the cup beam **230**.

[00111] As illustrated, two orifice beam drive cams **132** are located on outer ends of the camshaft **130** within the extractor frame and each connect to a cam follower and drive linkage that extends into the drive mechanism cavity **144** and attach to an end **140a** of the orifice beam **140**. The orifice beam drive cams **132** push the orifice beam downward via the cam follower and drive linkage, which is, in turn, pulled upward by a spring mechanism (not shown), allowing reciprocating movement of the orifice beam and the orifice tube within the strainer tube.

[00112] In one preferred aspect of the present invention, the return cam **232** is formed as a mathematical conjugate of the drive cam **136**. The drive cam **136** and return cam **232**, however, can be formed integral as two cam surfaces on a single body, or each can be formed as a single cam body as shown in the non-limiting example of FIG. 14.

[00113] To provide balance to the juice extractor machine during extractor operations, a counterweight is added to balance the offset nature of the camshaft. In the embodiments shown in FIGS. 14 and 15, two counterweights **250** are secured to the central portion of the camshaft **130** and offset the concentric rotation

of the cams, which causes vibration of the juice extractor during extractor operation. In another embodiment of the present invention shown in FIG. 16, a counterweight **252** is added to the main drive gear **122**, which could be positioned in a gearbox. FIG. 16 shows the main drive gear **122** that is connected to the camshaft **130**, and also the orifice beam drive cam **132** and a portion of the cam follower and drive linkage **254** that connects to a return spring and a drive linkage mechanism contained in the drive mechanism cavity **144** for reciprocating the orifice beam as the camshaft is rotated. It is evident, then, in accordance with the present invention, the counterweight can be mounted directly on the camshaft, for example, as the illustrated two counterweight members **250** mounted on a medial section of the camshaft, or mounted as a separate counterweight **252** on the large gear in the gearbox. Alternatively, both counterweights **250**, **252** could be used depending on the particular design choice of one skilled in the art.

[00114] In accordance with the present invention, the various cams **132**, **136** and **232** can be mounted to the camshaft **130** using a cup-drive, shaft-hub coupler **260** that frictionally secures the camshaft **130** with the cam hub **262** as shown in FIGS. 17 and 18. Non-limiting examples of the coupler **260** that can be used in the present invention include locking assemblies sold under the designation Ringfeder®, RfN 7013.1, which could be hub mounted with a countersunk flange as shown in FIG. 17, or with a locking assembly flange outside the hub bore, as shown in FIG. 18.

[00115] As illustrated, the camshaft **130** and the cam hub **262** of either the drive cam **136**, return cam **232** or orifice beam drive cam **132**, are cylindrically shaped

and devoid of keying. The coupler **260** preferably includes inner and outer rings **264, 266** having respective tapered overlapping surfaces **268, 270** and at least one fastener **272** such as the illustrated bolt for urging the inner and outer rings **264, 266** axially together. A flange can be connected to the inner ring to aid in preventing lateral movement of different members.

[00116] Each cam preferably includes at least one alignment feature **278** for facilitating relative alignment. This alignment feature could be an opening formed in each of the cams to permit an alignment rod to be inserted through the openings when the cams are relatively aligned properly to each other.

[00117] The juice extractor of the present invention also includes the integrated cup bridge and juice manifold **134** as shown in FIGS. 19-24. Juice piping extends from the opposing juice outlets positioned at the inner side panels and exits through the side of the juice extractor at the outer covers, thus eliminating the prior art piping arrangement where "bullhorn" pipes extended out the front and were prone to build-up of debris. As will also be explained below in greater detail, the strainer tube **86** is preferably bottom loaded, and includes an improved sealing assembly between the juice manifold and strainer tube. The integrated cup bridge and juice manifold **134** also includes a number of pressure actuated spray nozzles, i.e., pop-up nozzles, positioned on the integrated cup bridge and juice manifold **134**. These pop-up nozzles can be used for both oil recovery and extractor cleaning as will be explained in greater detail below.

[00118] Referring now to FIGS. 19-24, greater details of the integrated cup bridge and juice manifold **134** of

the present invention are illustrated. The integrated cup bridge and juice manifold **134** includes a front sloped wall **280** to permit product material to flow away from the structure during extractor operation. The integrated cup bridge and juice manifold **134** is preferably formed as a fabricated assembly that includes a weldment and associated construction forming an integrated juice manifold **281** within the assembly, as shown in greater details in FIGS. 20, 23 and 24. The integrated cup bridge and juice manifold **134** includes a rear wall **282**, the front sloped wall **280**, side end walls **284**, and the bottom wall as a weldment **286**. Fixed extractor cup positions **288** are defined by extractor cup mounts **290** that are substantially cylindrically formed and include a top flange **292** and mounting ridge **294** on which strainer tube support cones **296** are received.

[00119] As illustrated in FIG. 7 and described before, the integrated cup bridge and juice manifold **134** is mounted within the extractor frame between the inner side panels **142**, and includes juice outlets **298** juxtaposed to the inner side panels, such that the juice outlets are removed from the product material **143**, i.e., "juice and peel" area, to prevent build-up of peel and related byproducts. Build-up of byproducts was typical when juice outlets and the associated piping exited the juice extractor, for example out the front or rear, as "bullhorn" piping. As illustrated, the integrated cup bridge and juice manifold **134** extends transversely across the extractor frame **52** between the opposing inner side panels **142**.

[00120] As shown in FIGS. 19-21, 23 and 24, the integrated cup bridge and juice manifold **134** includes at least one fluid delivery conduit extending along an

upper portion of the structure where the rear wall **282** and front sloped wall **280** intersect. In the illustrated preferred embodiment shown in FIGS. 19-20, and 23-24, first and second fluid delivery conduits **300**, **302**, are formed by a L-bracket **304** and a medial insert wall **306** to define the first and second fluid delivery conduits **300**, **302**. Each conduit **300**, **302** has a first fluid inlet **308** in a side end wall **284** to be connected to a source of pressurized fluid and at least a first fluid outlet **310** positioned on an outer surface of the integrated cup bridge and juice manifold **134**, and more particularly, on the front sloped wall **280** for discharging fluid such as recycle fluid, for oil recovery during extractor operation. The second fluid delivery conduit **302** has a second fluid inlet **312** to be connected to a source of pressurized fluid, and at least a second fluid outlet **314** positioned on an outer surface of the integrated cup bridge and juice manifold **134**, and preferably on the front sloped wall **280** for discharging fluid for cleaning.

[00121] It should be understood, however, that the cleaning fluid and the oil recovery fluid can be switched to the other respective conduit. At each fluid outlet **310**, **314**, a pressure-actuated spray nozzle, formed as a pop-up spray nozzle, is positioned. This nozzle is explained later with reference to FIGS. 28-49. As illustrated in FIG. 19, a fluid outlet **310**, **314** is positioned adjacent each of the fixed extractor cup positions **288**. In the illustrated embodiment, there are five fixed extractor cup positions **288**, and six fluid outlets **310**, **314** for each of the first and second fluid outlets for allowing adequate fluid spray during recovery or cleaning. At each fixed extractor cup position **288**, opposed extractor cup fastener supports

320 are secured and permit the fixed extractor cups to be mounted and secured on the cup bridge by appropriate fasteners, as shown in FIG. 24.

[00122] As illustrated in FIGS. 24 and 25, the strainer tube **86** mounts through the bottom of the juice manifold **281**. A sealing assembly **320** seals the strainer tube **86** relative to the juice manifold **281**. In the illustrated and non-limiting embodiment shown in FIGS. 24 and 25, the sealing assembly **220** includes a threaded collar **322** positioned on an inside surface of the juice manifold through which the strainer tube **86** is received. A threaded insert **324** is received over an end of the strainer tube and received within the threaded collar **322** on an outside surface of the juice manifold **281**. A gasket **326** is positioned between the threaded collar **322** and strainer tube **86** and is compressed as the threaded insert **324** is tightened within the threaded collar **322**. The gasket **326** and inside surface of the threaded collar **322** include a beveled surface. A shoulder **328** is also formed on the strainer tube in which the gasket **326** and threaded insert **324** engage. A snap ring **330** can be positioned at an end of the strainer tube and maintain the threaded insert **324** on the strainer tube. A ring gasket **332** is preferably positioned between the threaded collar **322** and an inside surface of the juice manifold **281** and is compressed as the threaded insert **324** tightened within the threaded collar **322**.

[00123] It should be understood that the threaded collar **322** could potentially be part of the juice manifold. A beveled surface and an internal thread could be machined directly into the juice manifold, eliminating the need for a threaded collar. The threaded insert could potentially be part of the

strainer tube and could be machined directly onto the surface of the strainer tube, eliminating the requirements for a threaded insert.

[00124] Referring now to FIGS. 26 and 27, greater details of the orifice beam **140** (FIG. 26). The inner side panels **142**, and position of components (FIG. 27) are illustrated. As explained before, the orifice beam **140** supports the orifice tubes **56**. The orifice beam **140** includes ends **140a** that extend through the window openings **152** to engage the drive mechanism positioned within the drive mechanism cavity **144** as explained before. The drive mechanism, in one preferred aspect of the present invention, is a pull-rod assembly that interconnects a cam follower and drive linkage **254**, which includes a return spring mechanism in the upper part of the juice extractor **100**, as shown in FIG. 27. A seal **154**, as explained before, is formed at the juncture of orifice beam and the beam opening forming the window, as shown in FIGS. 7 and 27, to prevent product material from entering the drive mechanism cavity during juice extractor operation. This seal preferably comprises a labyrinth seal and includes a seal and seal strip member **154a** that is moveable within the seal. The seal could be a plastic seal and the seal strip members could be sheet metal pieces moveable within the seal. Other seals can be used as suggested by those skilled in the art.

[00125] FIG. 27 also illustrates how at least one tapered spray nozzle, and preferably a plurality of tapered spray nozzles, are mounted flush on a wall surface, and preferably on the inner side panel at a fluid outlet for discharging fluid and cleaning product material during extractor operation. It is possible to place a nozzle in the drive mechanism cavity also.

Each tapered spray nozzle is mounted flush on a wall surface. Fluid conduits **340** permit fluid flow to the nozzles, as shown in FIGS. 7 and 27. The configuration of a tapered spray nozzle of the present invention is explained below relative to FIGS. 46-54.

[00126] Referring now to FIGS. 28-45, details of a pressure-actuated spray nozzle **350** formed as a pop-up nozzle and positioned adjacent fixed extractor cups on the integrated cup bridge and juice manifold **134** are explained. The pressure-actuated spray nozzle **350** includes a tubular housing **352** and a nozzle body **354** received within the tubular housing and moveable between a retracted OFF position and an extended ON or spray position. A spring **356** is used for urging the nozzle body **354** toward the retracted OFF position and is shown in detail in FIGS. 30 and 32. The nozzle body includes a lower tubular member and upper spray directing member that are screwed together in one non-limiting example.

[00127] A flange **358** is connected to a lower end of the nozzle body to engage adjacent lower portions of the tubular housing **352** when in the extended spray position. A mushroom head **360** is connected to an upper end of the nozzle body **354** to engage adjacent upper portions of the tubular housing when in the retracted OFF position. The nozzle body **354** also includes a lower tubular member **362** and an upper spray directing member **364** connected thereto. This lower tubular member **362** is rotatably captured within the housing **352**. The upper spray directing members **364** are rotatably settable with respect to the lower tubular member to permit adjustment of the spray direction. The tubular housing preferably is formed as an externally threaded tubular body and a flange **366** is

connected to an upper end. The angled interior and exterior surfaces **368a**, **368b** prevent rotation, but allow axial movement and the "pop-up" function. The pressure-actuated spray nozzle **350** is typically screwed into a fluid outlet **310**, **314** and a threadlock composition or other thread locking mechanism used to set the desired angle or position.

[00128] Referring now to FIGS. 46-54, details are illustrated of the tapered spray nozzle **370** that is mounted flush on a wall surface at a fluid outlet, such as a fluid outlet **372** on the inner side panels (FIG. 27). Naturally, the tapered spray nozzle can be positioned at other locations in the extractor. The tapered spray nozzle **370** is configured for preventing build-up on the spray nozzle of any product material during extractor operation. The term "tapered" as used for this nozzle encompasses many different configurations, including a spray nozzle that is conical, semi-hemispherical, rounded, or other shapes as suggested by those skilled in the art.

[00129] The tapered spray nozzle **370** includes a spray nozzle head **374** having at least one fluid spray orifice **376** and a spray disc **378** inserted within the fluid spray orifice. The spray disc **378** has a fluid outlet opening **380** configured for forming a predetermined fluid spray pattern of fluid used for cleaning. The opening **380** is preferably geometrically configured and can be rhomboid, curved, elliptical, circular or other shapes as suggested by those skilled in the art. In one aspect of the present invention, the spray nozzle head **374** and spray disc **378** are each rotatable for selecting a desired fluid spray direction. In another aspect of the present invention as shown in greater detail in FIG. 49, the spray nozzle head **374** includes

at least two fluid spray orifices **376**. A nozzle fastening body **382** is secured on the wall surface at a fluid outlet and receives the spray nozzle head **374**. It includes a fluid channel **384** formed in the nozzle fastening body **382** and communicates with the fluid spray orifice **376** to the fluid outlet.

[00130] The tapered spray nozzle **370** of the present invention is typically threaded within a fluid outlet and a threadlock composition or other thread locking mechanism used for tightening the spray nozzle relative to a desired water spray direction. The spray disc is also rotated to a desired location. The nozzle fastening body is threaded on an exterior surface and receives a nozzle retaining ring **386** having internal threads as shown in FIGS. 53 and 54 for retaining the nozzle head thereon when the nozzle retaining ring is secured.

[00131] This application is related to copending patent applications entitled, MULTI-LANE FRUIT GUIDE ASSEMBLY FOR A JUICE EXTRACTOR AND RELATED METHODS, attorney docket no. 11-12797 (56075); MULTI-LANE FRUIT GUIDE ASSEMBLY HAVING INTEGRAL RIDGE ENDS FOR A JUICE EXTRACTOR AND RELATED METHODS, attorney docket no. 11-12858 (56076); JUICE EXTRACTOR WITH DRIVE AND RETURN CAMS FOR EXTRACTOR CUP MOVEMENT, attorney docket no. 11-12792 (56074); JUICE EXTRACTOR WITH COUNTERWEIGHT OPERATIVELY ENGAGED WITH CAMSHAFT, attorney docket no. 11-12794 (56073); JUICE EXTRACTOR INCLUDING FRICTIONAL SHAFT-HUB COUPLINGS FOR DRIVE CAMS AND RELATED METHODS, attorney docket no. 11-12859 (56077); JUICE EXTRACTOR WITH INTEGRAL JUICE MANIFOLD AND CUP BRIDGE, attorney docket no. 11-12759 (56072); JUICE EXTRACTOR WITH BOTTOM LOADING STRAINER TUBE, attorney docket no. 11-12791 (56071); JUICE EXTRACTOR WITH JUICE MANIFOLD

HAVING SIDE OUTLET FOR JUICE, attorney docket no. 11-12860 (56078); JUICE EXTRACTOR WITH ORIFICE TUBE BEAM DRIVE EXTENDING INTO SIDE PANELS, attorney docket no. 11-12870 (56079); JUICE EXTRACTOR INCLUDING PRESSURE-ACTUATED NOZZLE AND ASSOCIATED METHODS, attorney docket no. 11-12861 (56080); JUICE EXTRACTOR WITH TAPERED CLEAN UP NOZZLE, attorney docket no. 11-12862 (56081); JUICE EXTRACTOR DESIGN, attorney docket no. 11-12863 (56082); and JUICE EXTRACTOR INCLUDING FRUIT FEEDER DECOUPLING DETECTOR AND ASSOCIATED METHODS, attorney docket no. 11-12864 (56083) which are filed on the same date and by the same assignee and inventors, the disclosures of which are hereby incorporated by reference.

[00132] Many modifications and other embodiments of the invention will come to the mind of one skilled in the art having the benefit of the teachings presented in the foregoing descriptions and the associated drawings. Therefore, it is understood that the invention is not to be limited to the specific embodiments disclosed, and that modifications and embodiments are intended to be included within the scope of the appended claims.

THAT WHICH IS CLAIMED IS:

1. A fruit guide assembly to guide fruit from a fruit conveyor to a multi-position fruit feeder for a fruit juice extractor, the fruit guide assembly comprising:

a frame to be positioned between the fruit conveyor and the multi-position fruit feeder;

a vibrator removably fastened to said frame to be removable therefrom in the upward direction; and

a fruit guide body removably fastened to said frame to be removable therefrom in an upward direction and having an upper surface with alternating ridges and valleys therein defining a plurality of fruit lanes.

2. A fruit guide assembly according to Claim 1 wherein said fruit guide body has a plurality of fastener receiving passageways therein at side and medial positions; and further comprising a respective fastener extending through each fastener receiving passageway to fasten said fruit guide body to said frame at the side and medial positions.

3. A fruit guide assembly according to Claim 1 wherein said frame comprises a base plate having an opening in a medial portion thereof; and wherein said vibrator at least partially extends through the opening in said base plate.

4. A fruit guide assembly according to Claim 3 wherein said frame further comprises a pair of mounting ears connected to opposite sides of said base plate; and further comprising a plurality of vibration dampeners and associated fasteners connected to said pair of mounting ears.

5. A fruit guide assembly according to Claim 3 further comprising a mounting flange connected between said vibrator and said base plate.

6. A fruit guide assembly according to Claim 1 wherein said fruit guide body comprises spaced apart upper and bottom walls so that said fruit guide is a hollow fruit guide body.

7. A fruit guide assembly according to Claim 6 wherein said hollow fruit guide body comprises rotationally molded polyethylene.

8. A fruit guide assembly to guide fruit from a fruit conveyor to a multi-position fruit feeder for a fruit juice extractor, the fruit guide assembly comprising:

a frame to be positioned between the fruit conveyor and the multi-position fruit feeder;

a hollow fruit guide body connected to said frame and comprising a bottom wall and an upper wall spaced therefrom, said upper wall having a series of alternating ridges and valleys therein defining a plurality of fruit lanes.

9. A fruit guide assembly according to Claim 8 wherein said hollow fruit guide body has a plurality of fastener receiving passageways therein at side and medial positions; and further comprising a respective fastener extending through each fastener receiving passageway to fasten said hollow fruit guide body to said frame at the side and medial positions.

10. A fruit guide assembly according to Claim 8 wherein said hollow fruit guide body is removably fastened to said frame to be removable therefrom in an upward direction.

11. A fruit guide assembly according to Claim 8 further comprising a vibrator removably

fastened to said frame to be removable therefrom in an upward direction.

12. A fruit guide assembly according to Claim 11 wherein said frame comprises a base plate having an opening in a medial portion thereof; and wherein said vibrator at least partially extends through the opening in said base plate.

13. A fruit guide assembly according to Claim 12 wherein said frame further comprises a pair of mounting ears connected to opposite sides of said base plate; and further comprising a plurality of vibration dampeners and associated fasteners connected to said pair of mounting ears.

14. A fruit guide assembly according to Claim 12 further comprising a mounting flange connected between said vibrator and said base plate.

15. A fruit guide assembly according to Claim 8 wherein said hollow fruit guide body comprises a polymer.

16. A fruit guide assembly according to Claim 8 wherein said hollow fruit guide body comprises rotationally molded polyethylene.

17. A fruit guide assembly according to Claim 8 wherein said bottom wall has stiffening features therein.

18. A method for making a fruit guide assembly to guide fruit from a fruit conveyor to a multi-position fruit feeder for a fruit juice extractor, the method comprising:

removably fastening a vibrator to a frame to be positioned between the fruit conveyor and the multi-position fruit feeder so that the vibrator is removable in an upward direction; and

removably fastening a fruit guide body to the frame and comprising a bottom wall and an upper wall spaced therefrom so that the fruit guide body is removable in the upward direction, the upper wall having a series of alternating ridges and valleys therein defining a plurality of fruit lanes.

19. A method according to Claim 18 wherein the fruit guide body has a plurality of fastener receiving passageways therein at side and medial positions; and wherein removably fastening the fruit guide body to the frame comprises securing a respective fastener through each fastener receiving passageway.

20. A method according to Claim 18 wherein the frame comprises a base plate having an opening in a medial portion thereof; and wherein removably fastening the vibrator comprises removably fastening the vibrator to at least partially extend through the opening in the base plate.

21. A method for making a fruit guide body for a fruit guide assembly to guide fruit from a fruit conveyor to a multi-position fruit feeder for a fruit juice extractor, the method comprising:

molding the fruit guide body from a moldable material to have a bottom wall and an upper wall spaced therefrom so that the fruit guide is a hollow fruit guide body with the upper wall having a series of alternating ridges and valleys therein defining a plurality of fruit lanes.

22. A method according to Claim 21 wherein molding comprises rotationally molding.

23. A method according to Claim 21 wherein the moldable material comprises polyethylene.

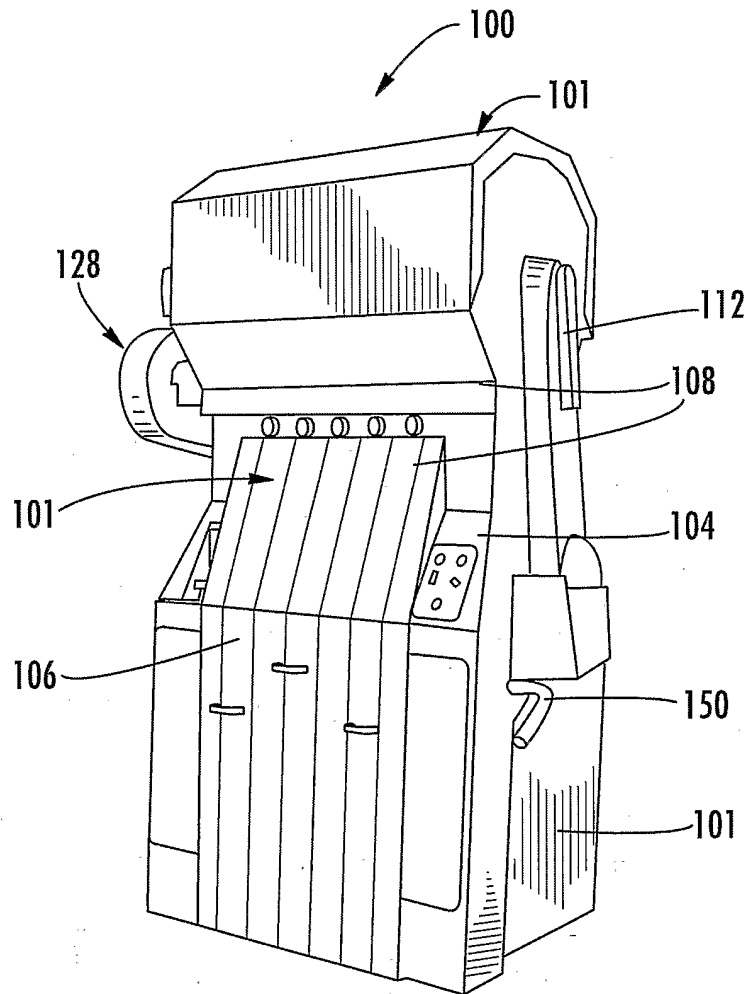
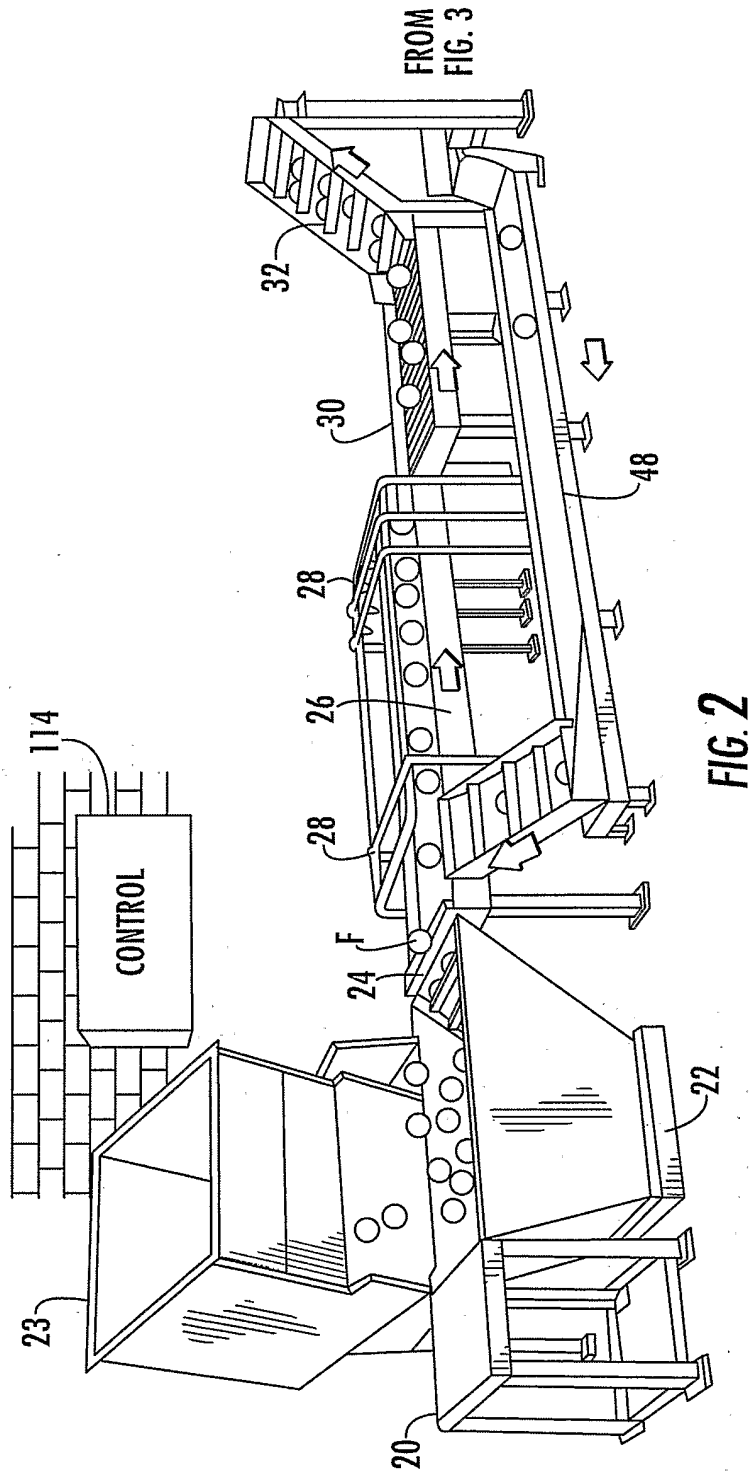
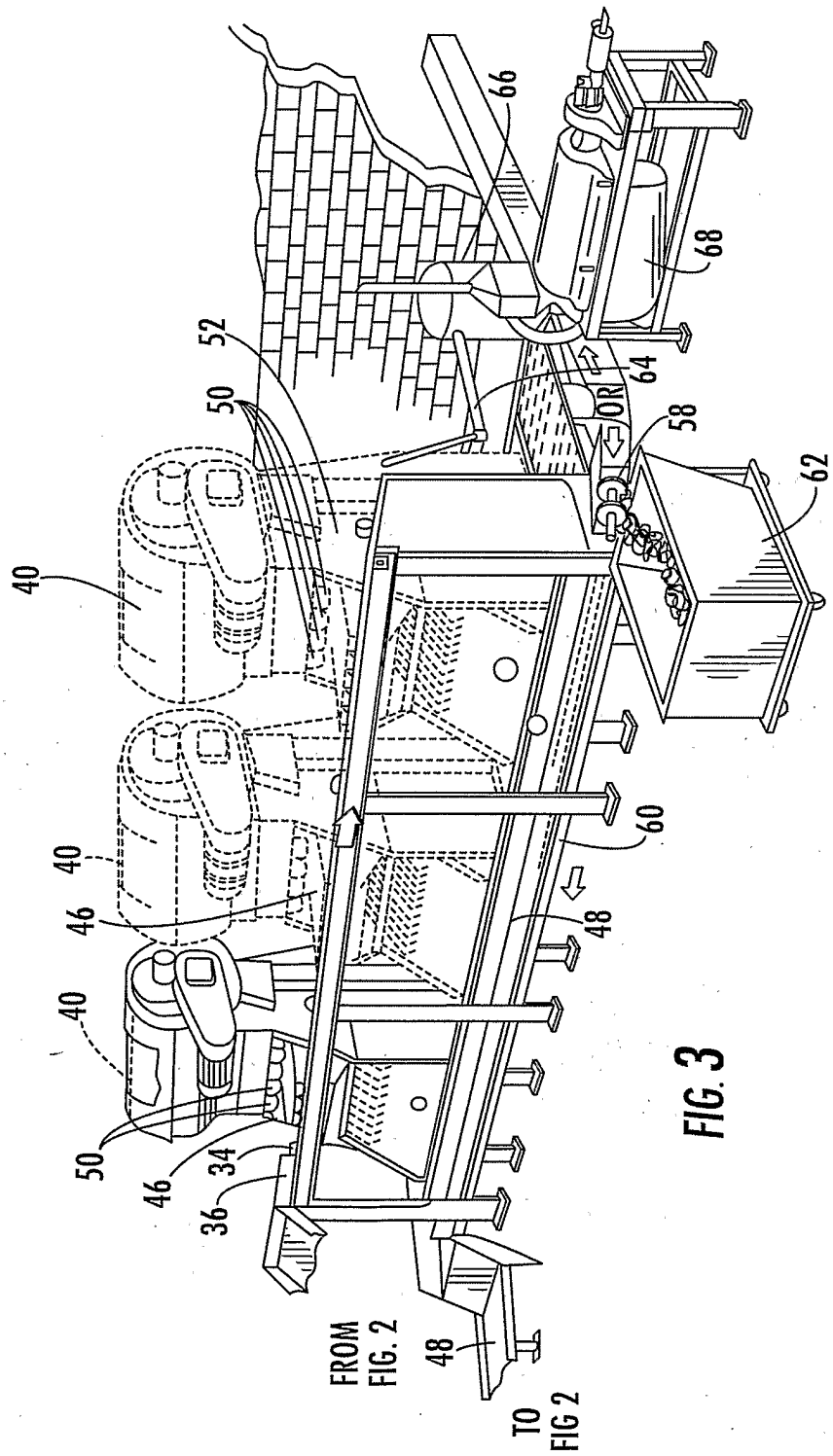

FIG. 1





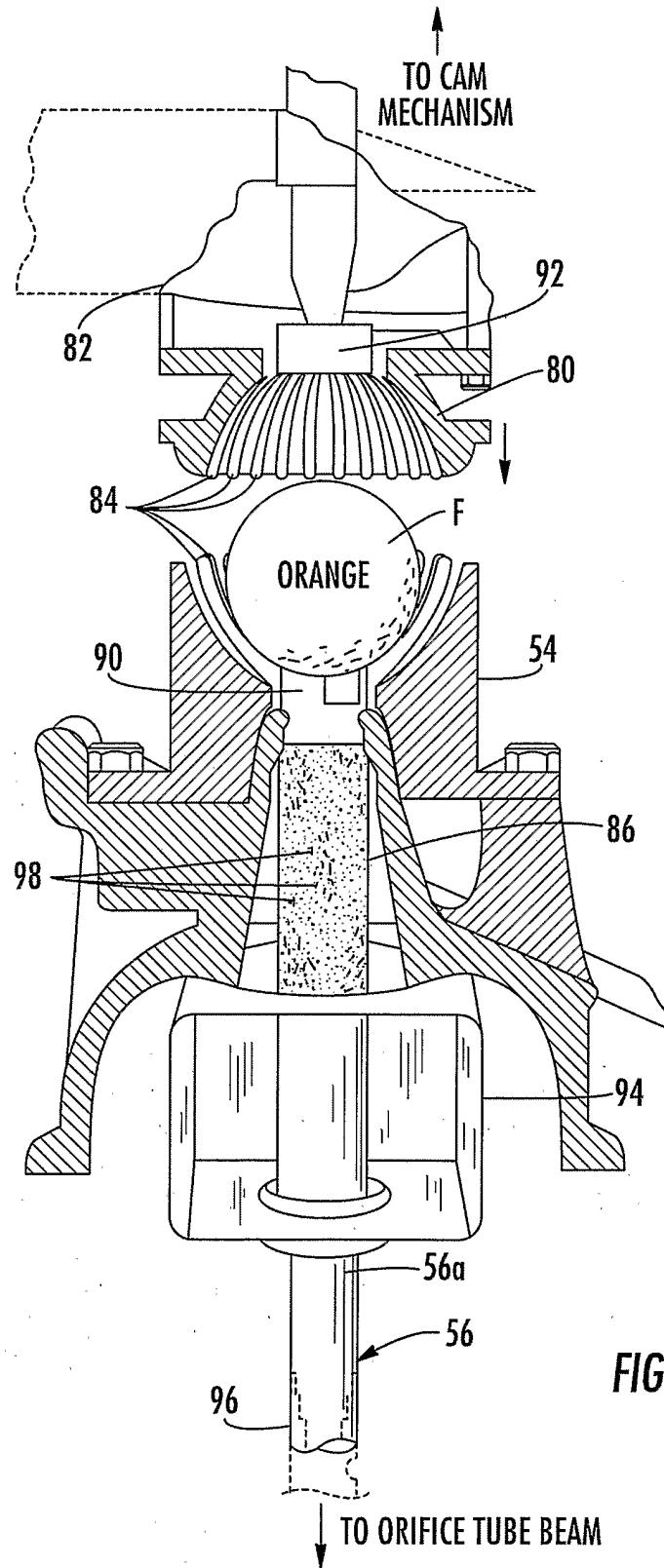

FIG. 4

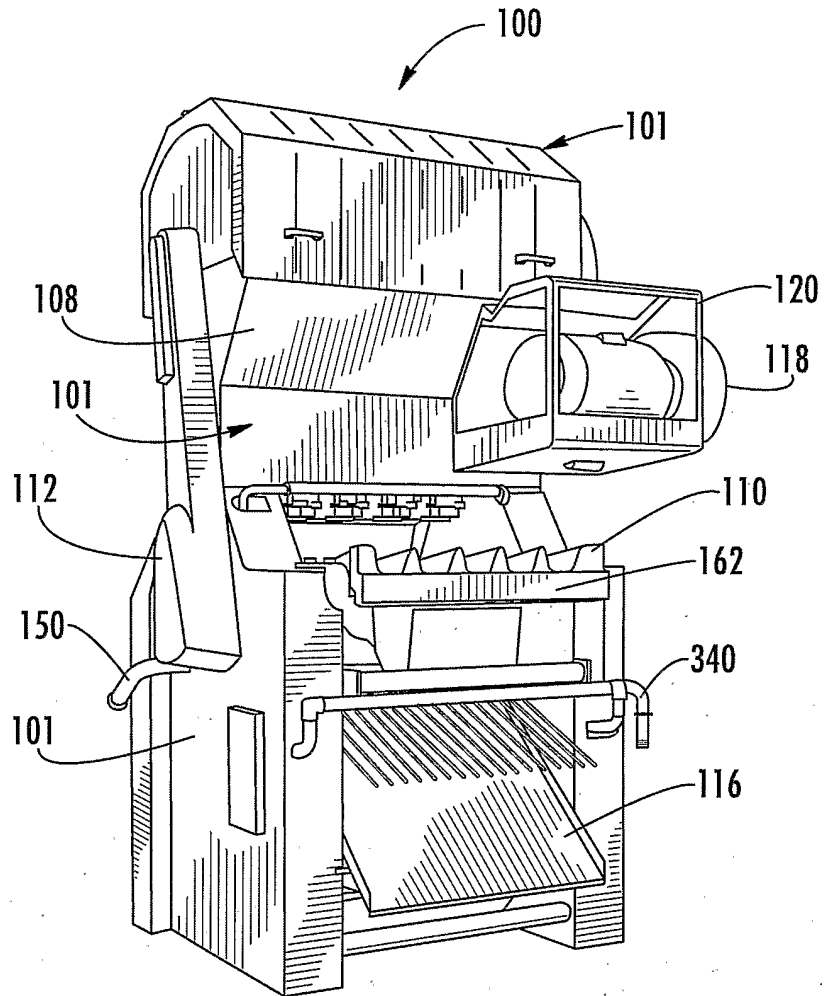

FIG. 5

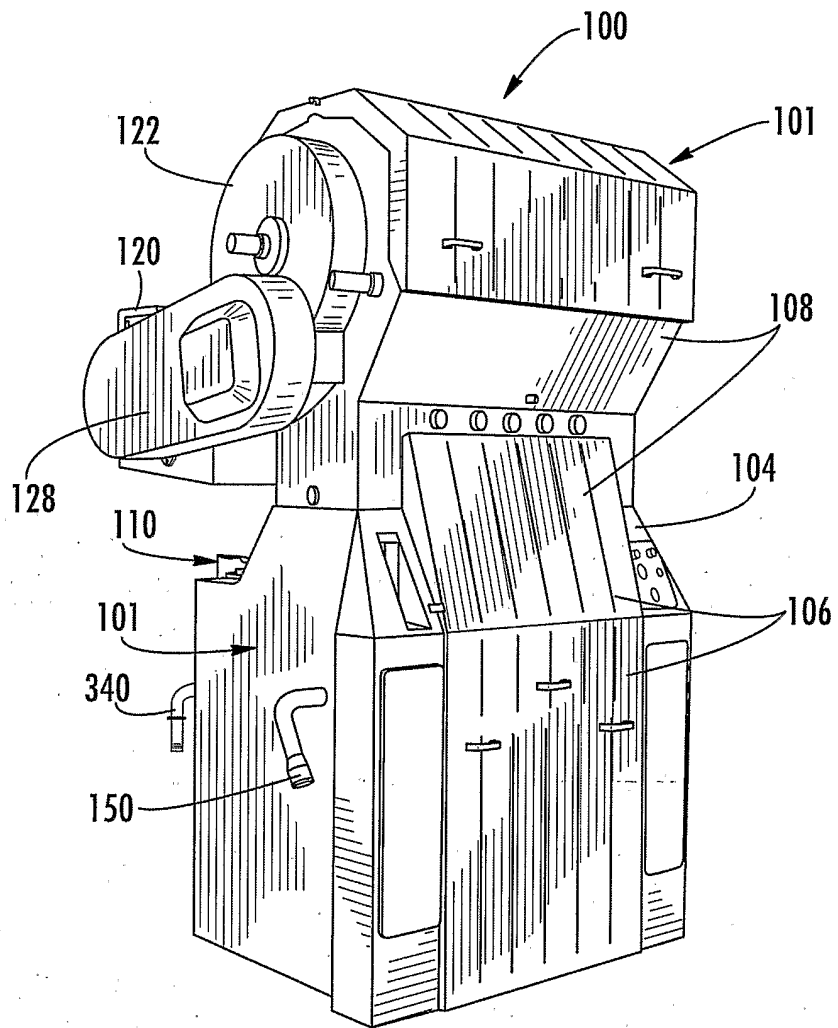

FIG. 6

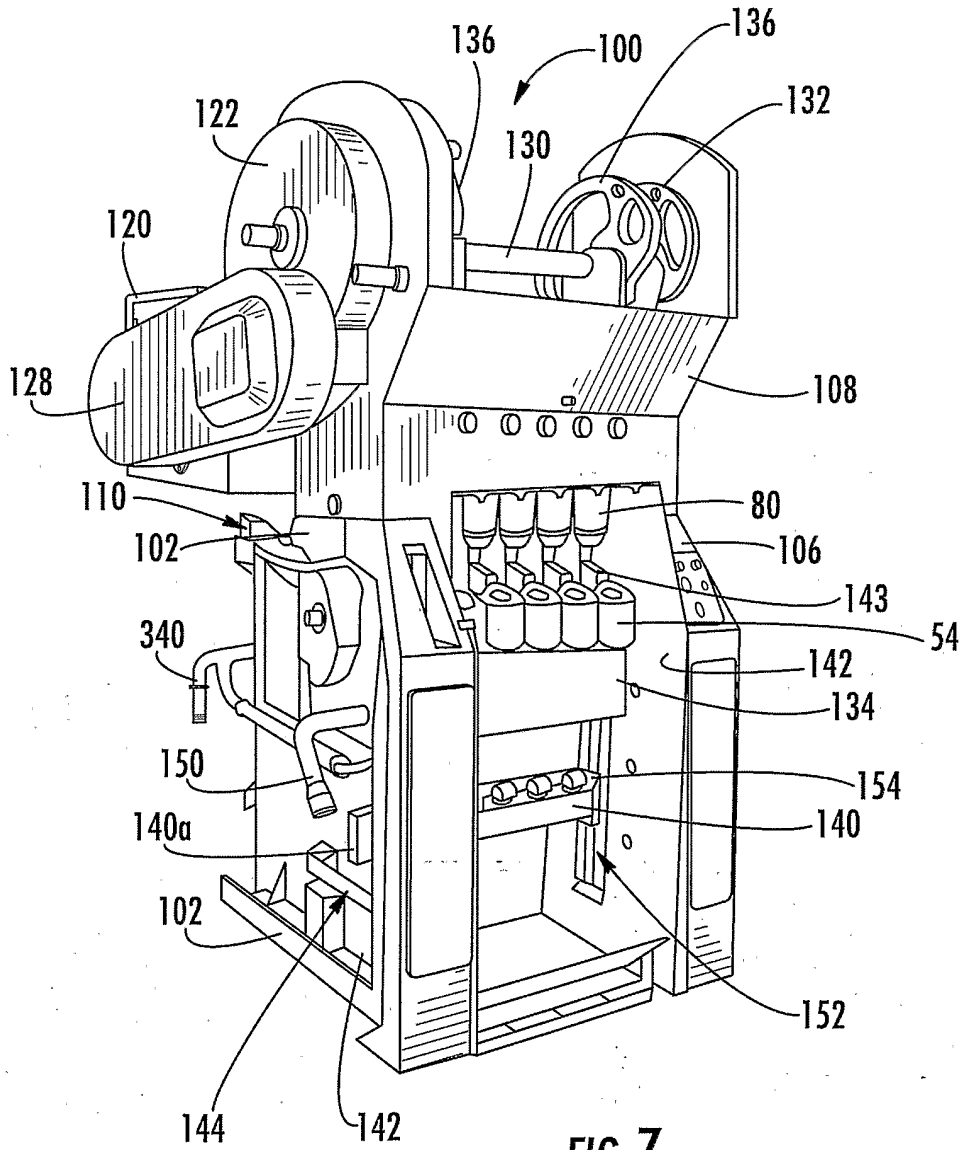

FIG. 7

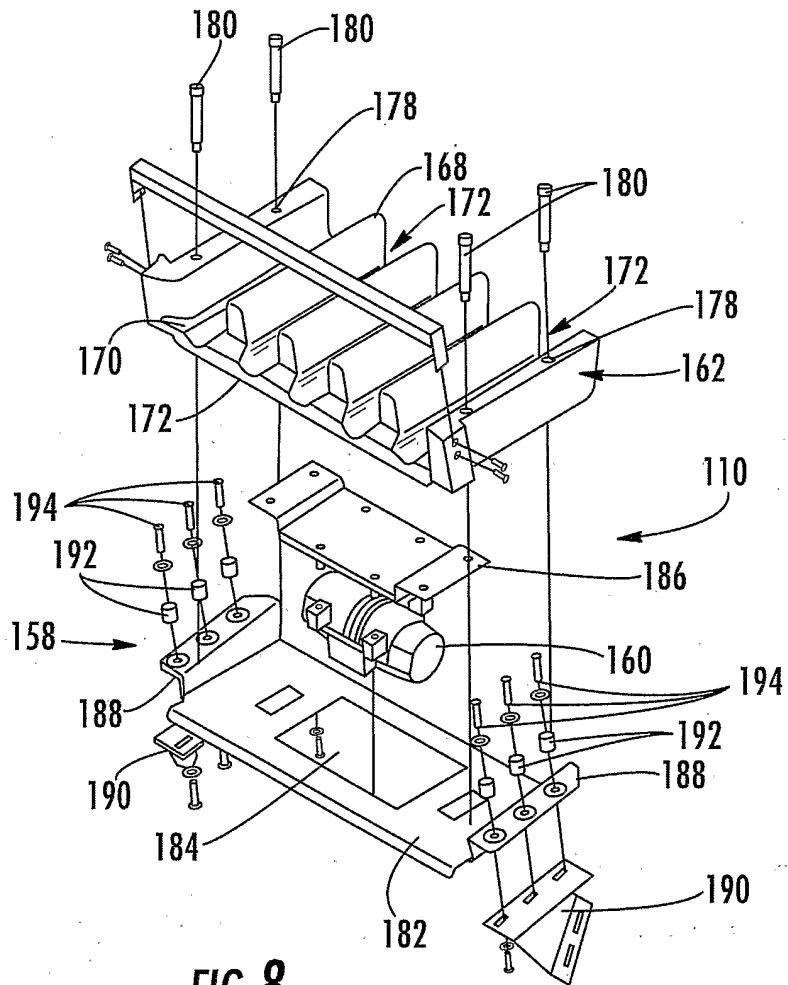

FIG. 8

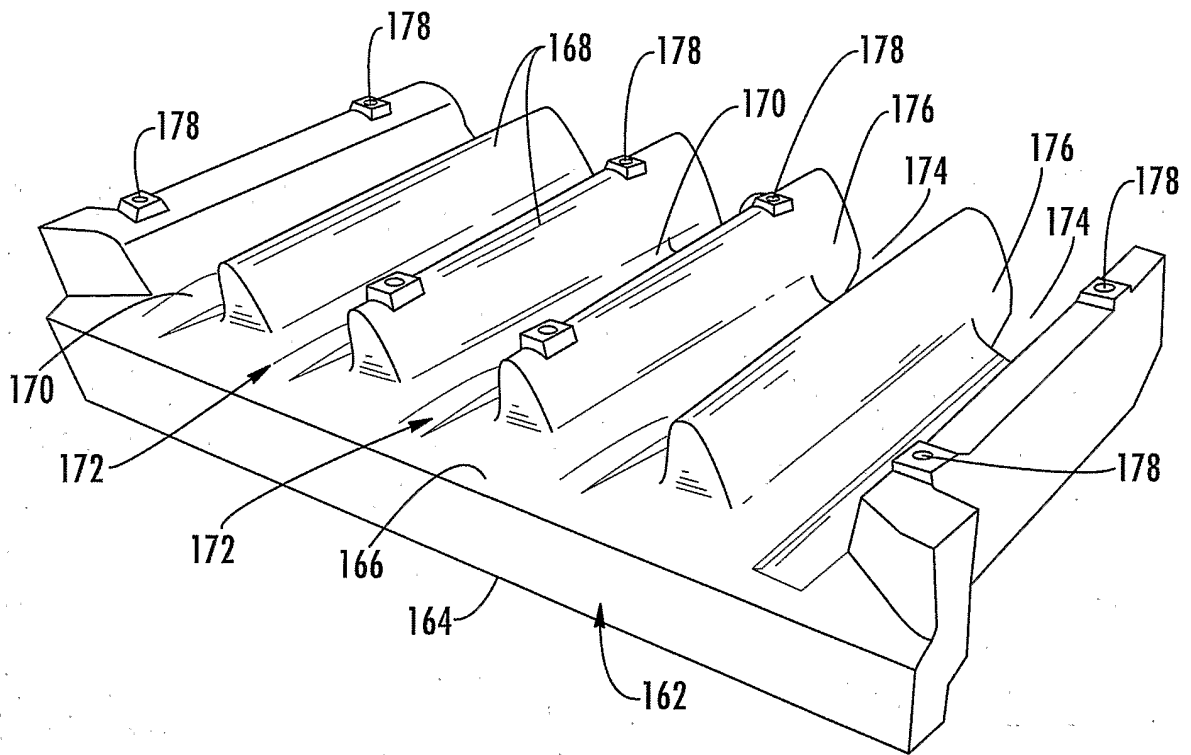

FIG. 9

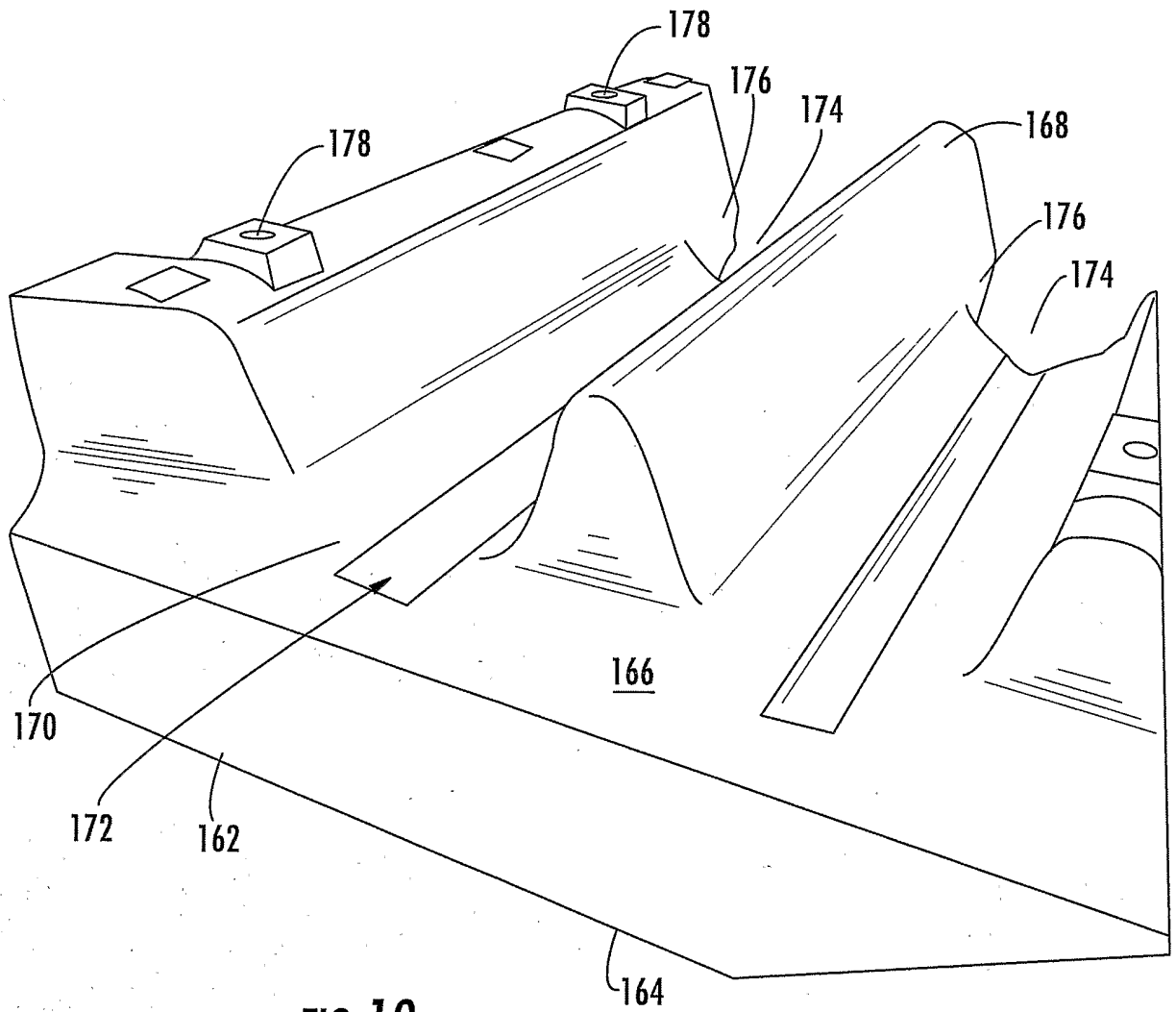

FIG. 10

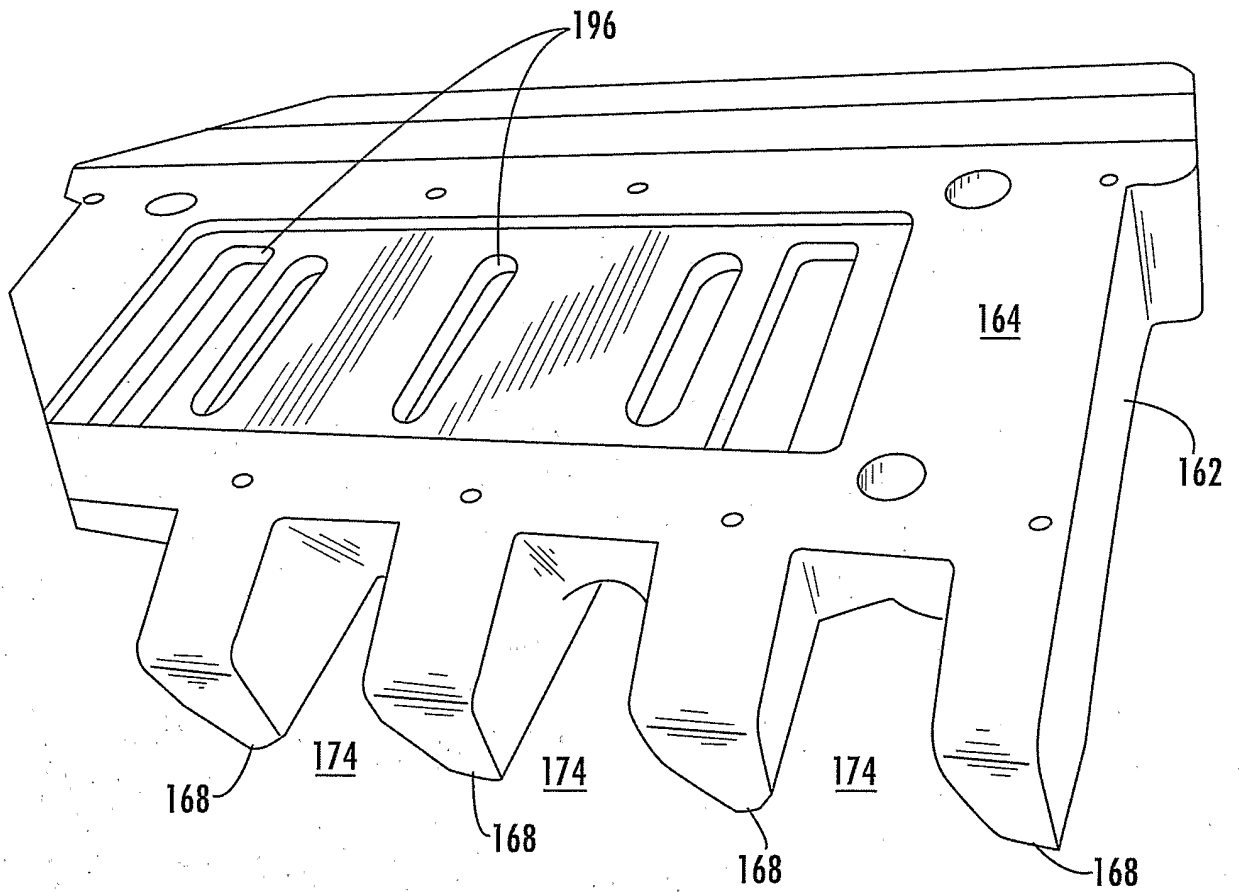

FIG. 11

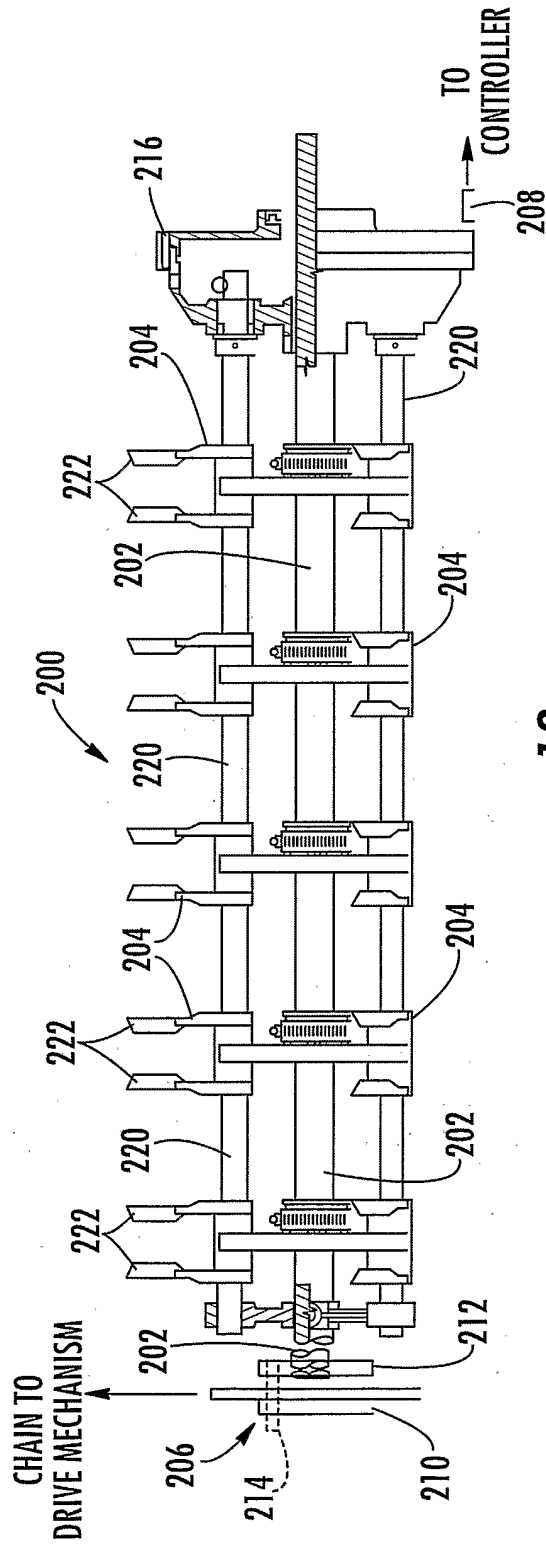

FIG. 12

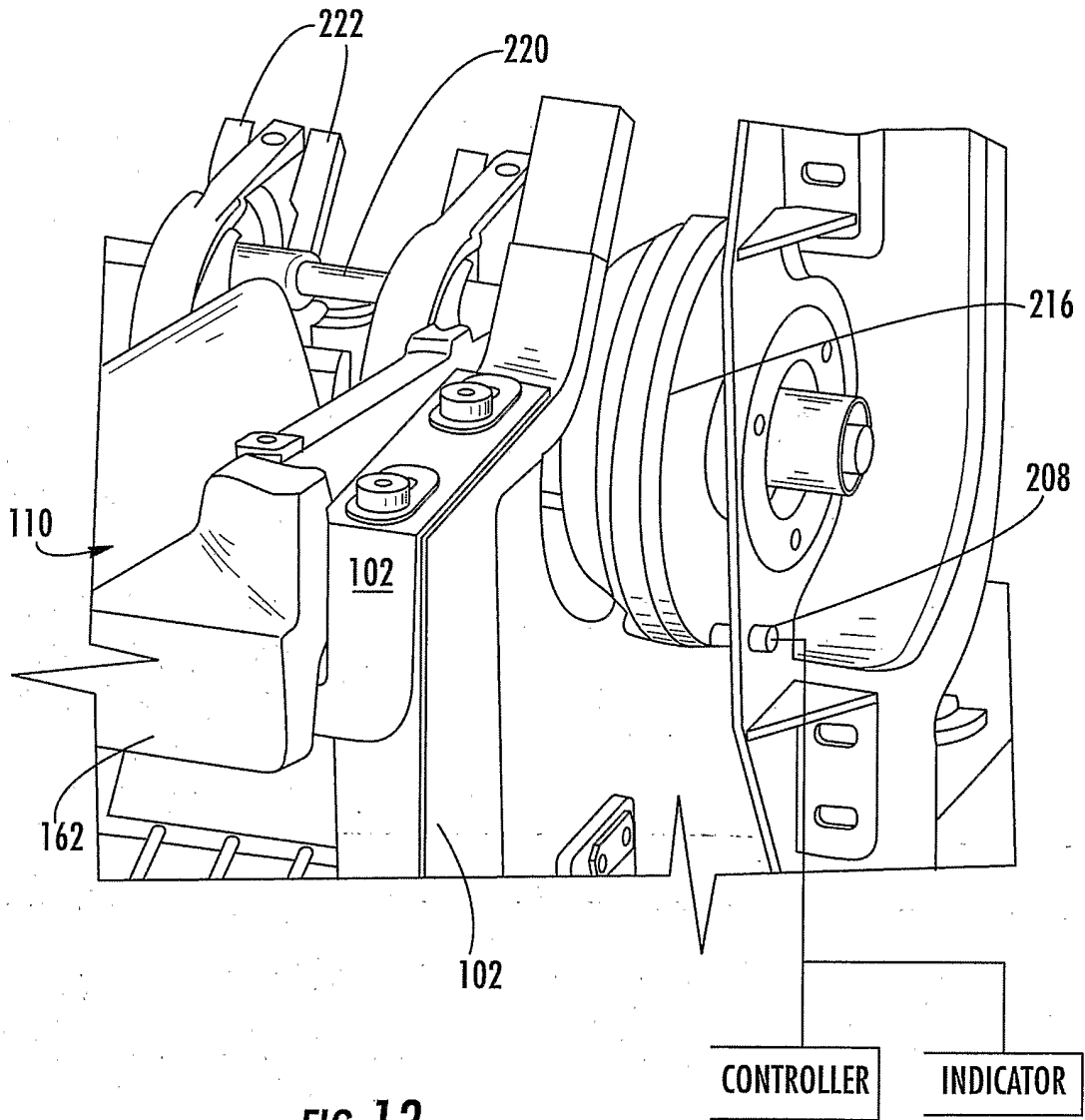

FIG. 13

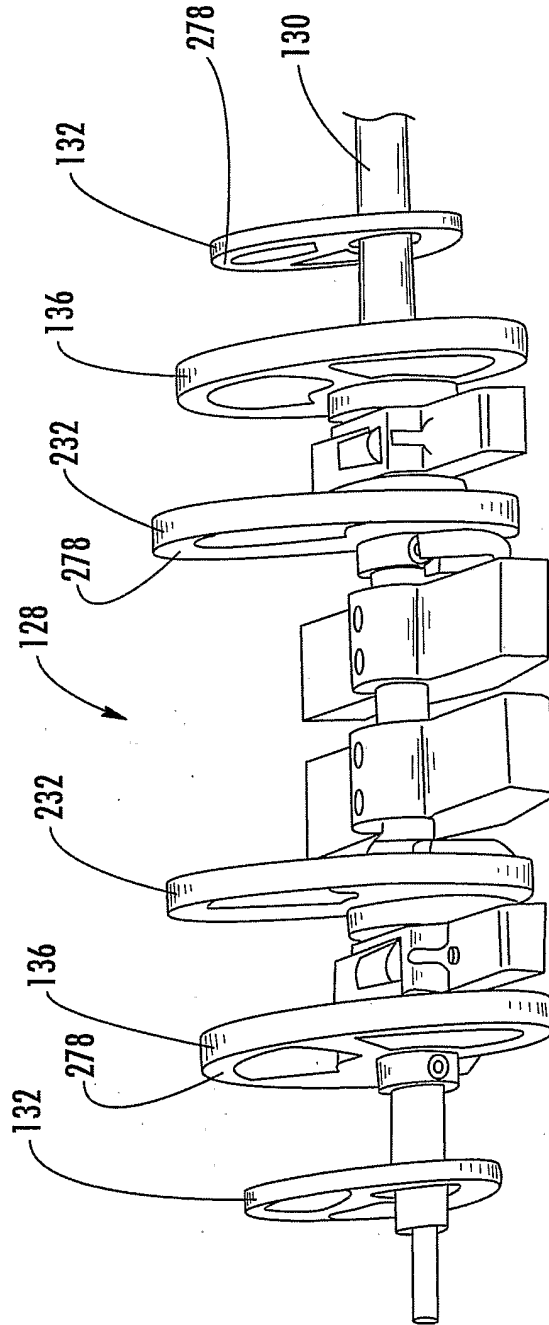

FIG. 14

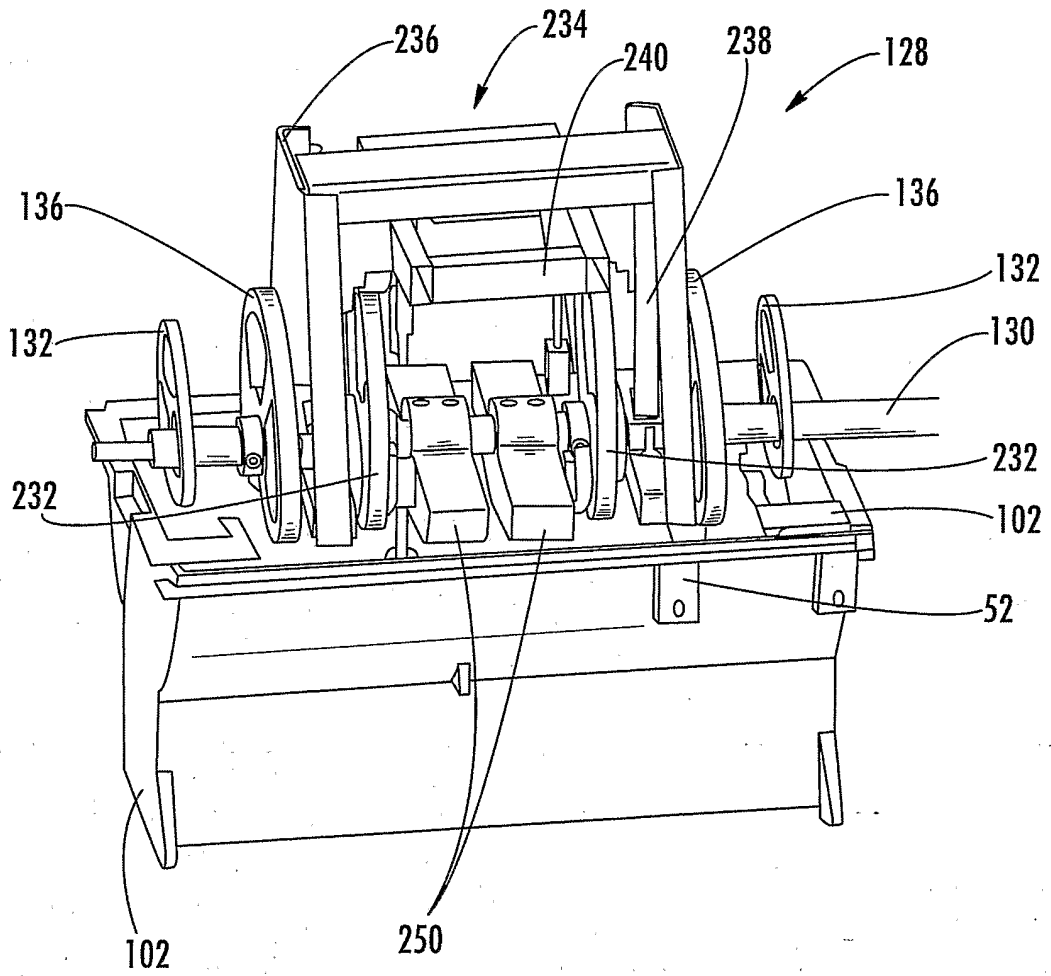

FIG. 15

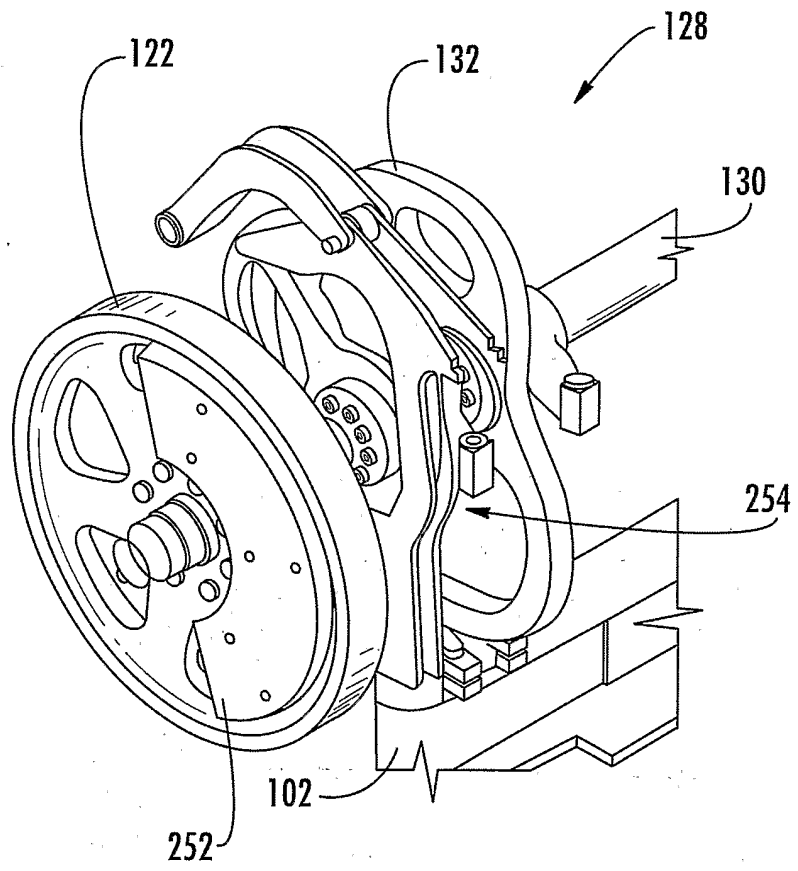

FIG. 16

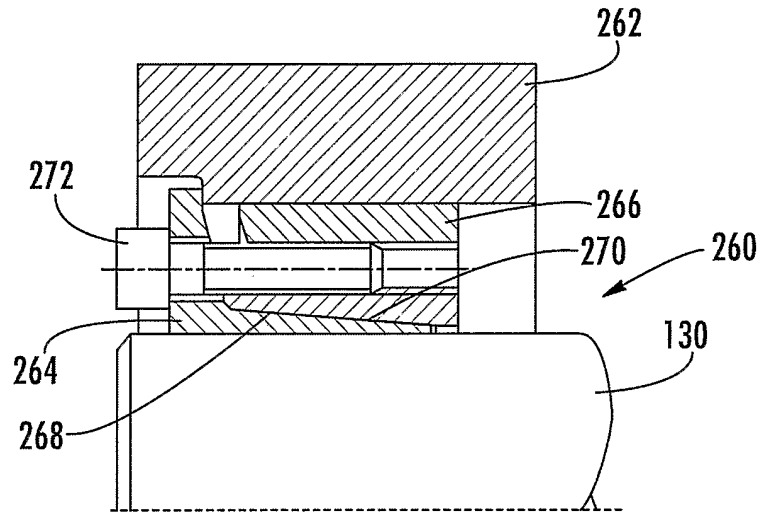

FIG. 17

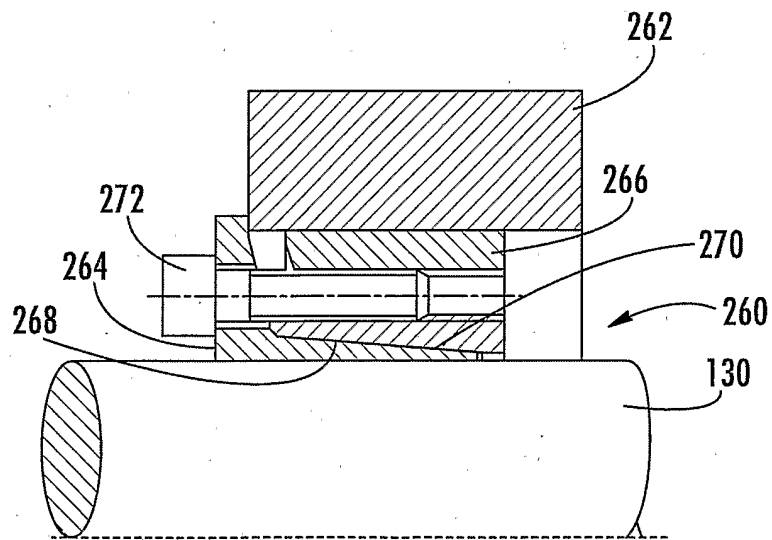

FIG. 18

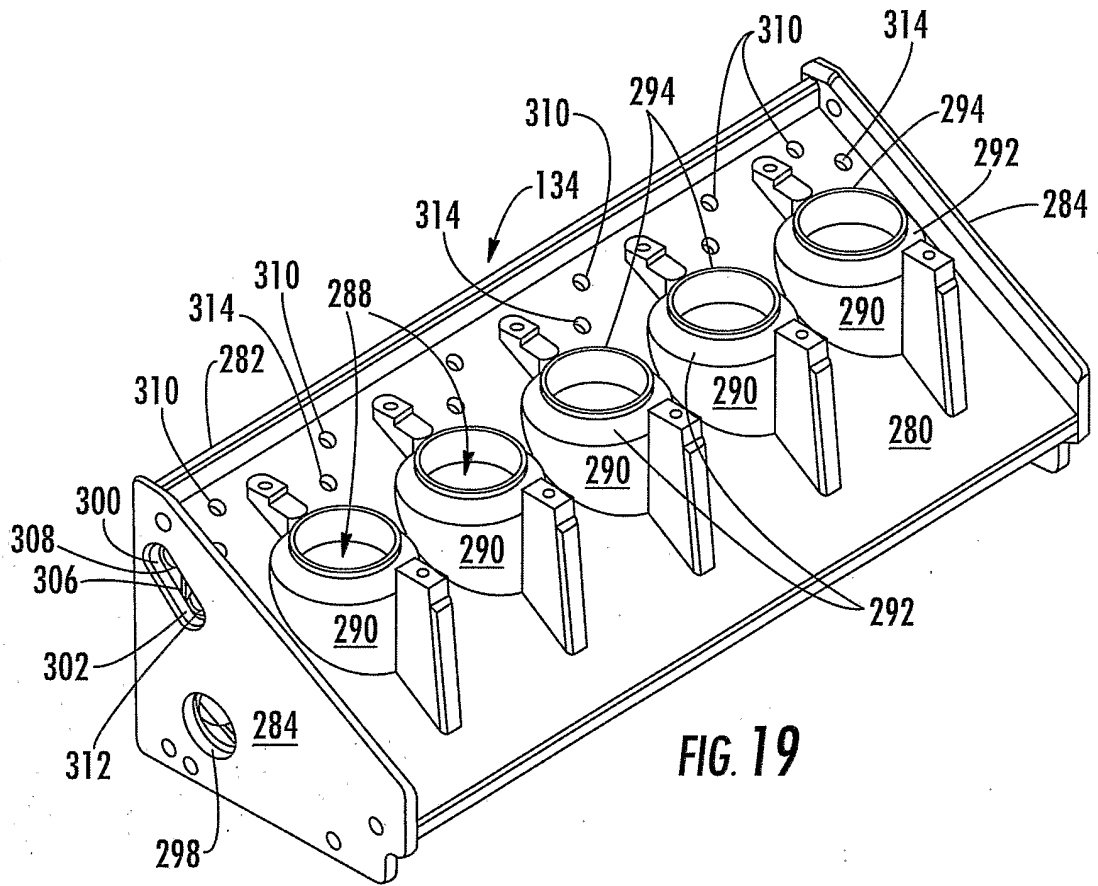

FIG. 19

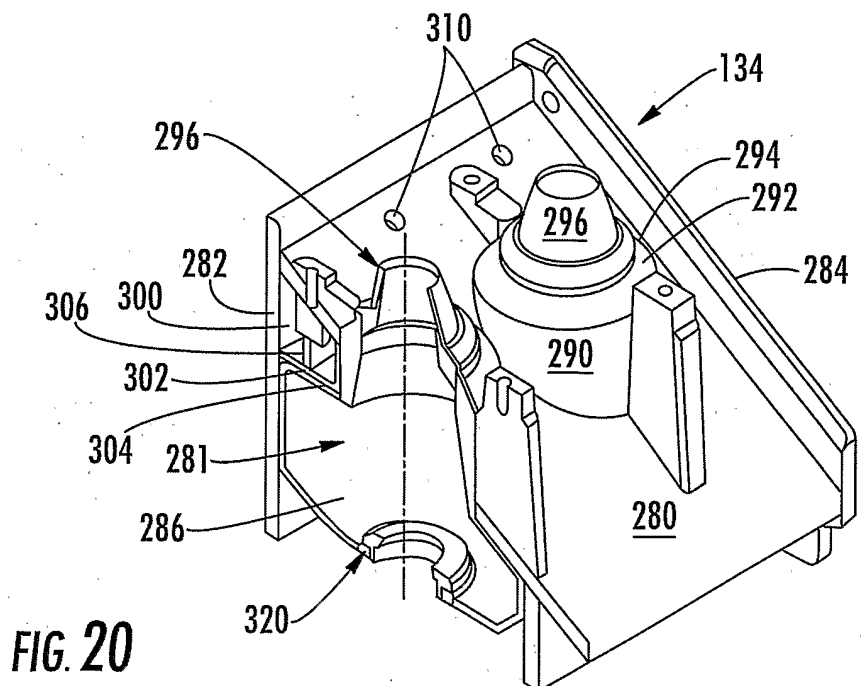
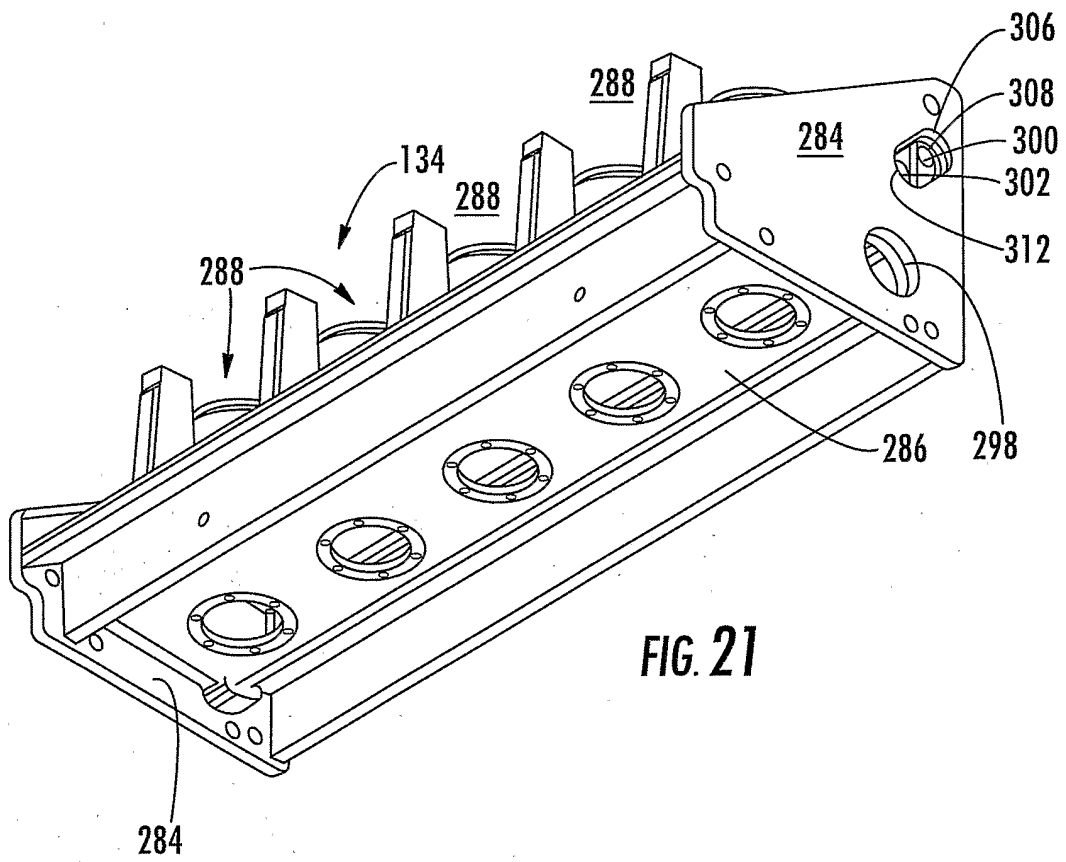

FIG. 20



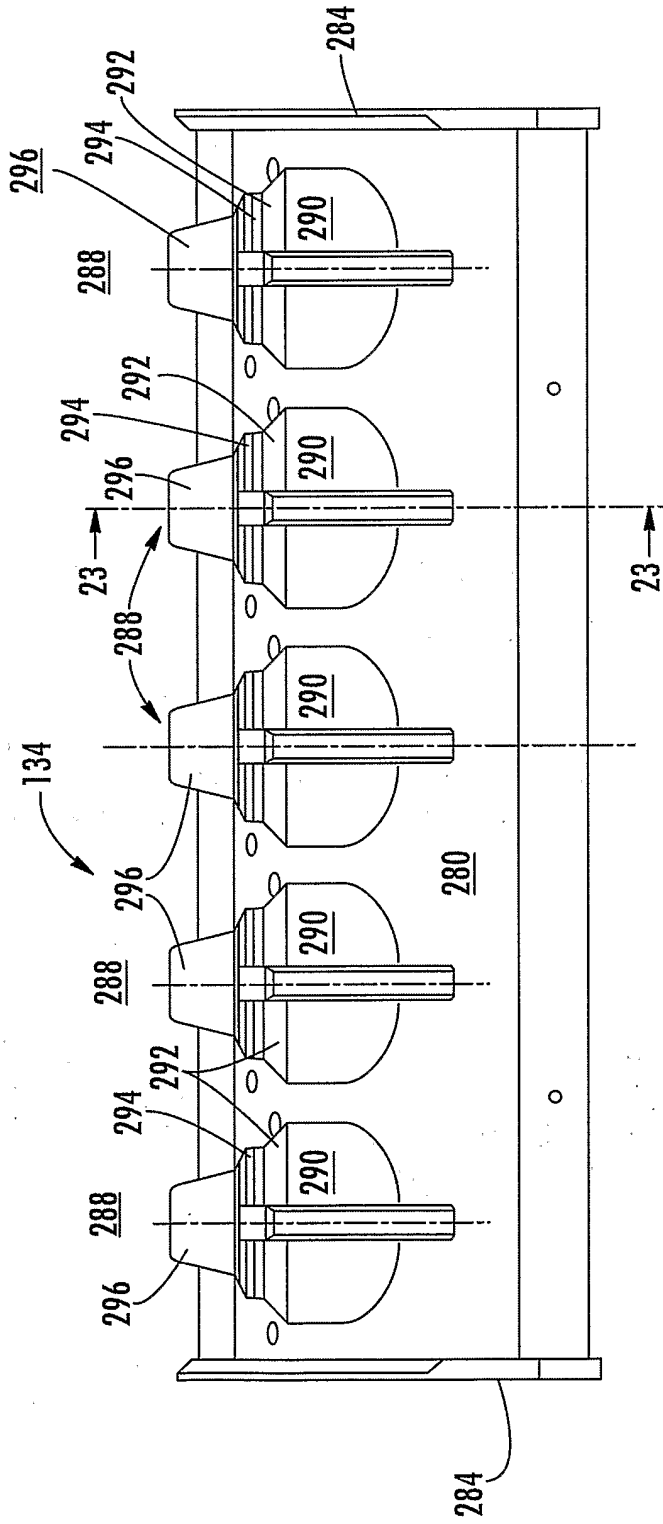

FIG. 22

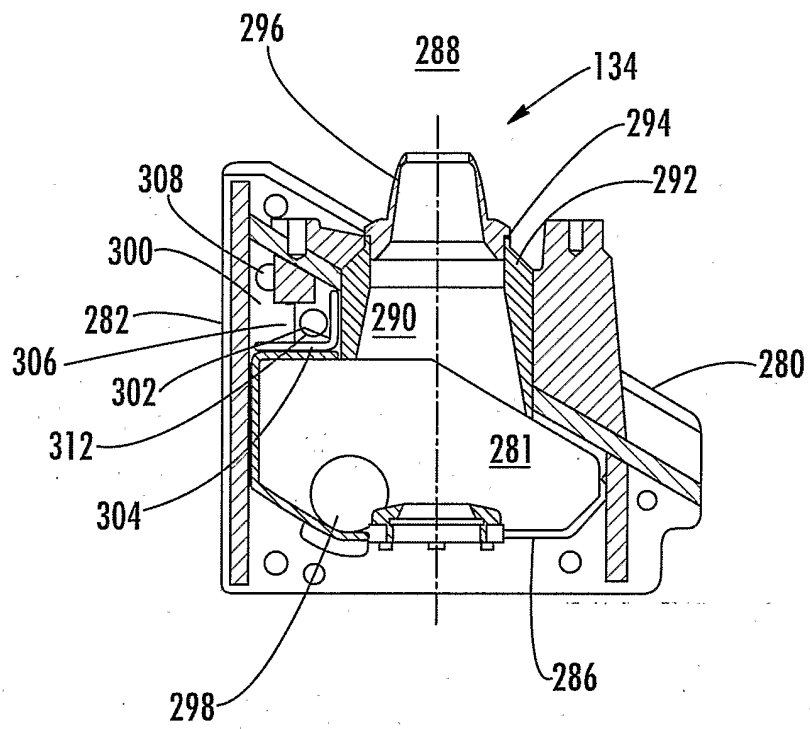

FIG. 23

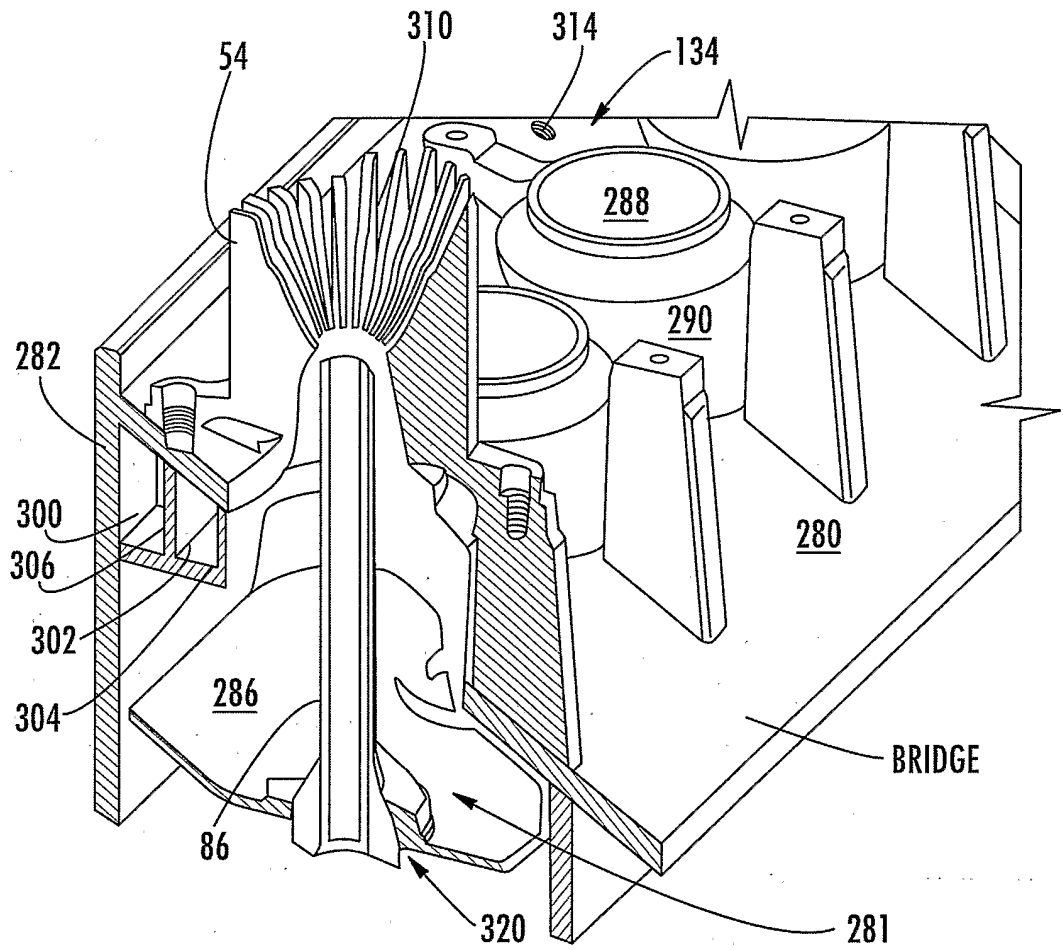
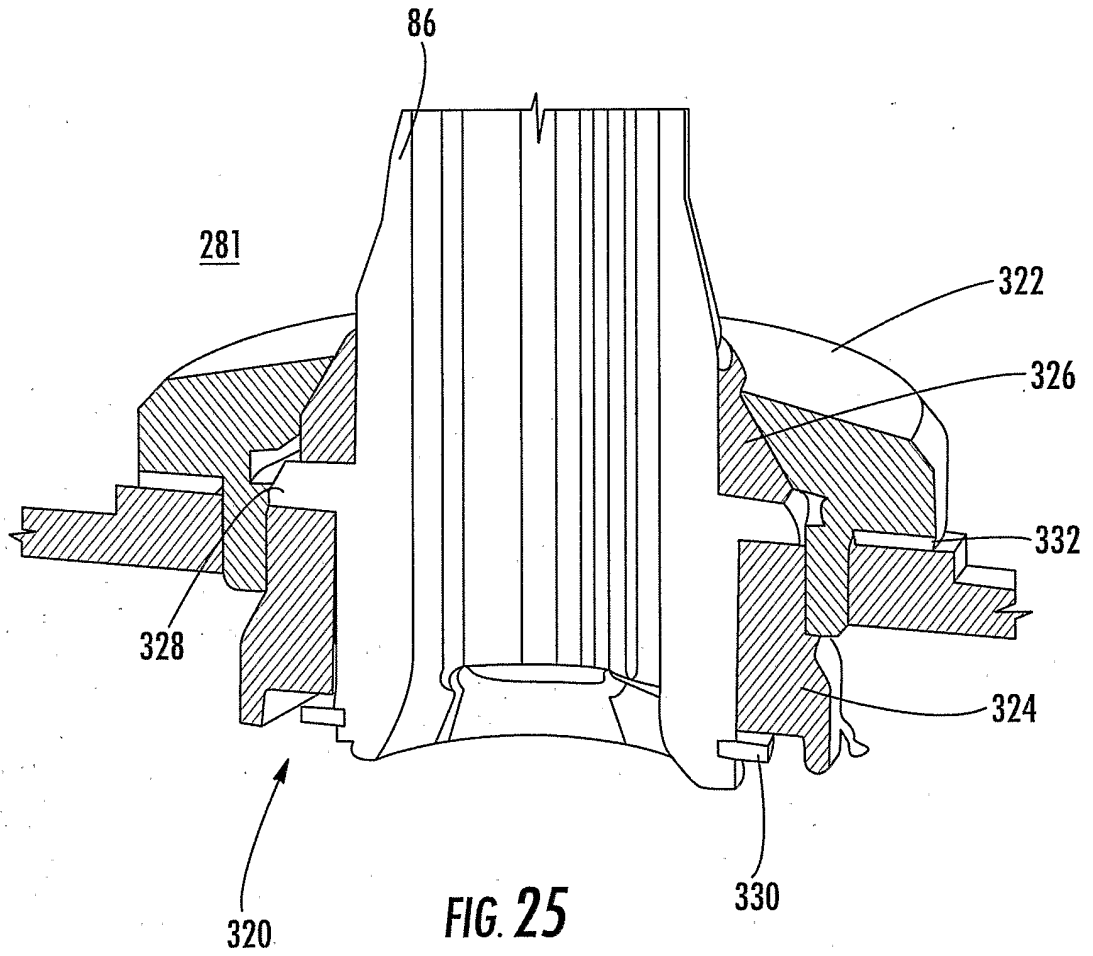

FIG. 24



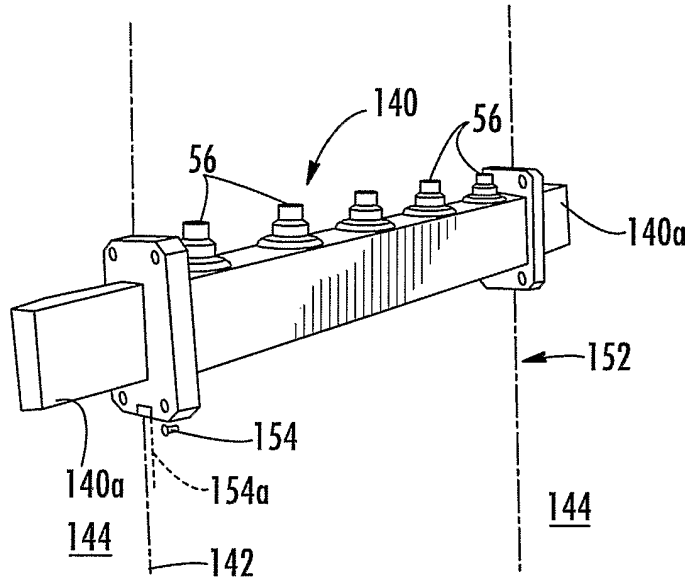

FIG. 26

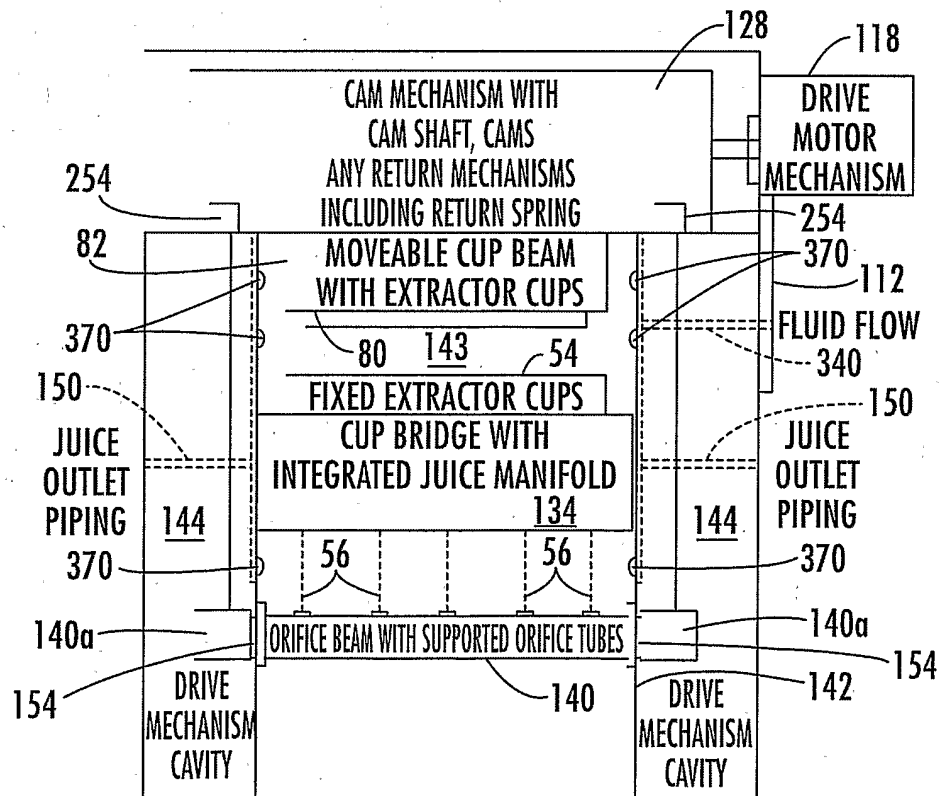

FIG. 27

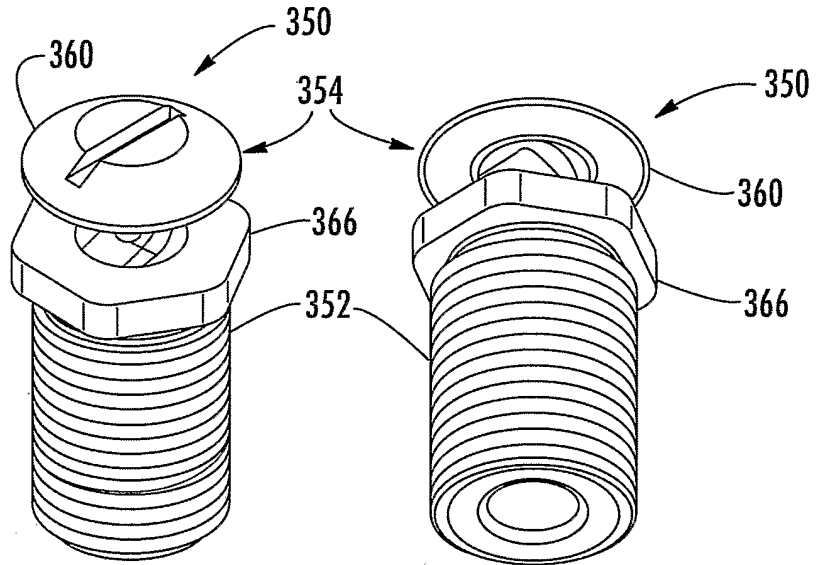

FIG. 28

FIG. 29

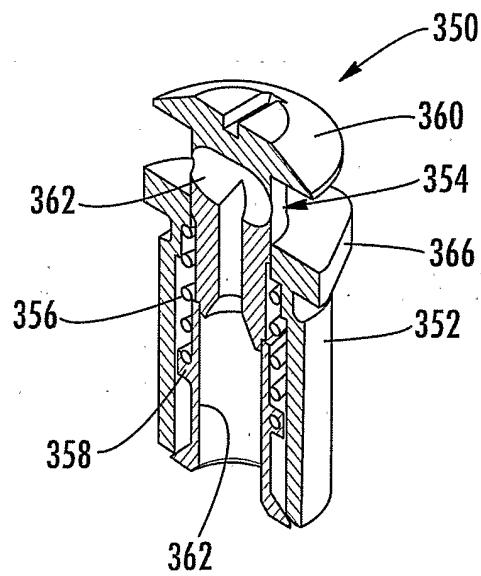

FIG. 30

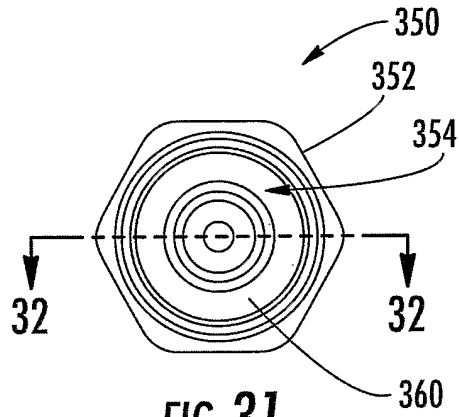

FIG. 31

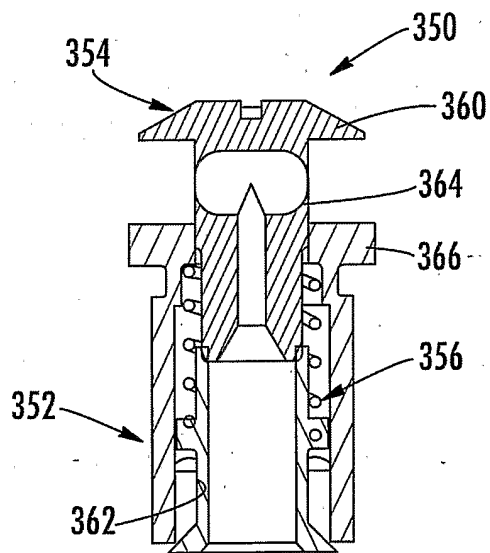

FIG. 32

27/33

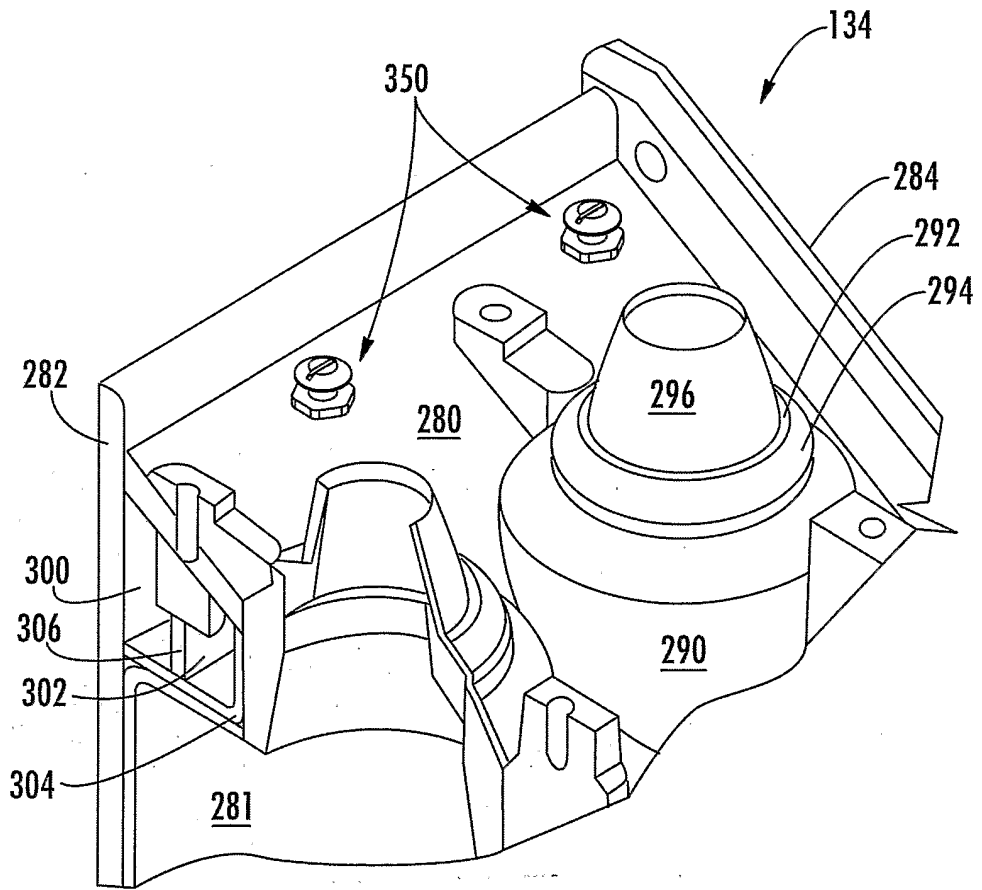

FIG. 33

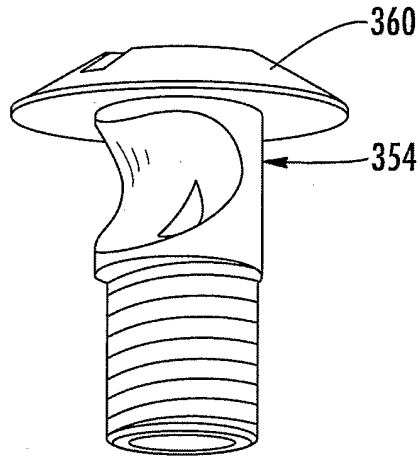

FIG. 34

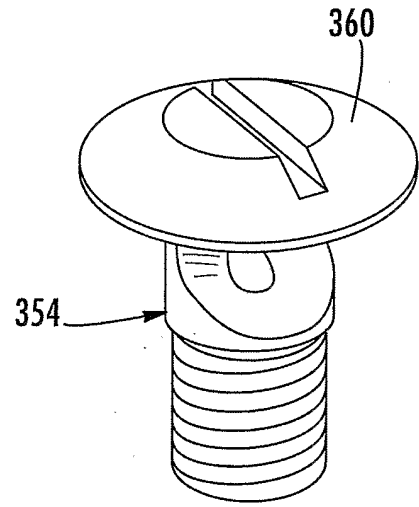

FIG. 35

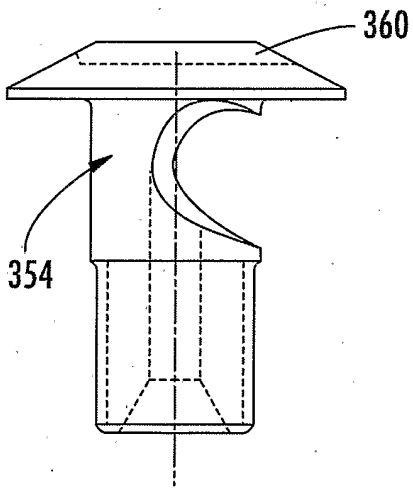

FIG. 36

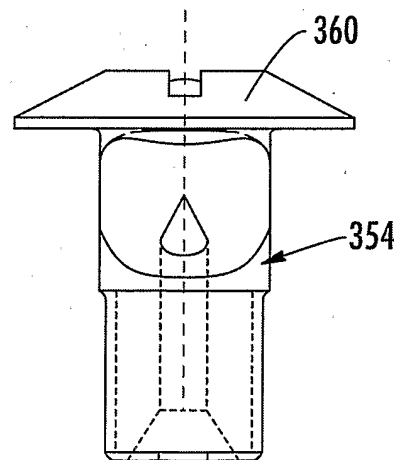

FIG. 37

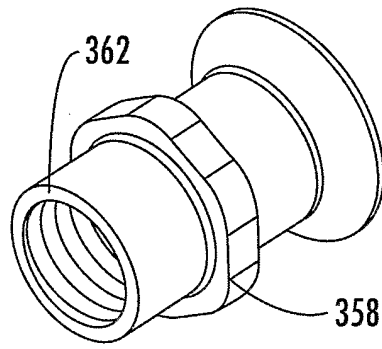

FIG. 38

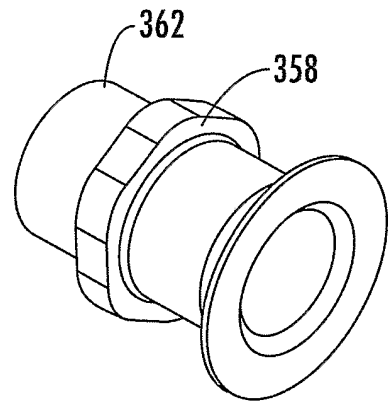

FIG. 39

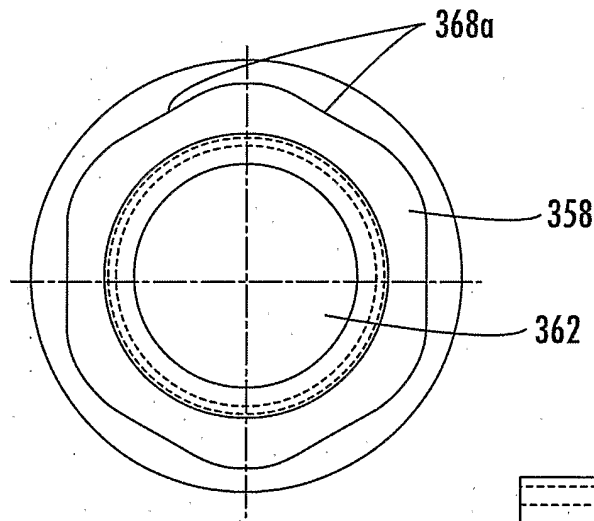

FIG. 40

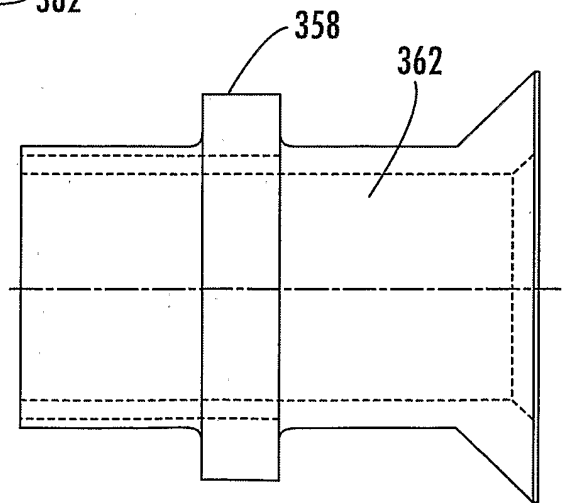

FIG. 41

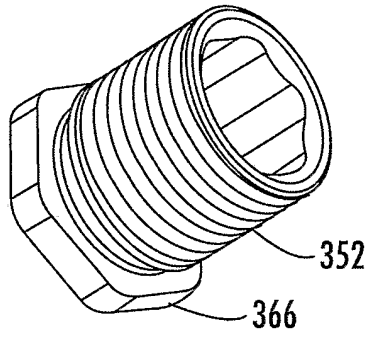

FIG. 42

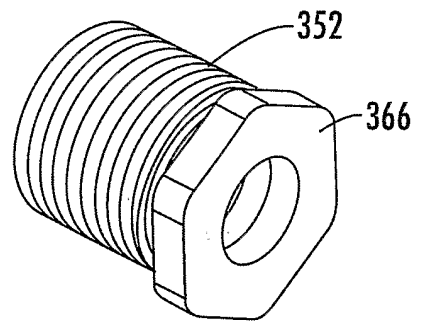

FIG. 43

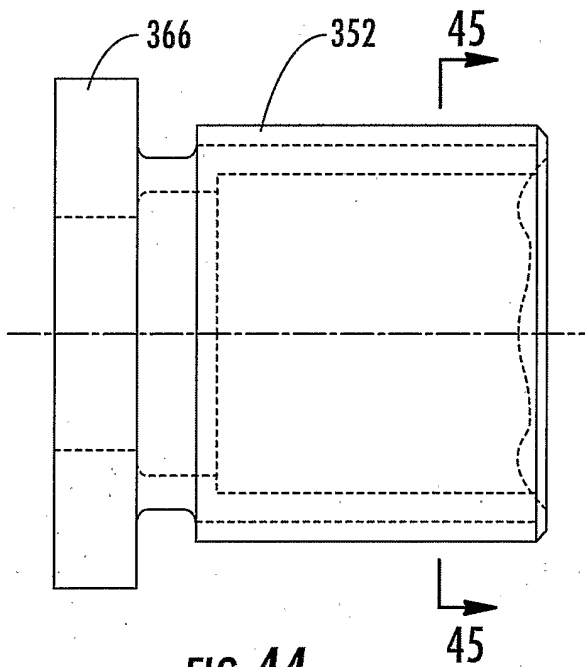

FIG. 44

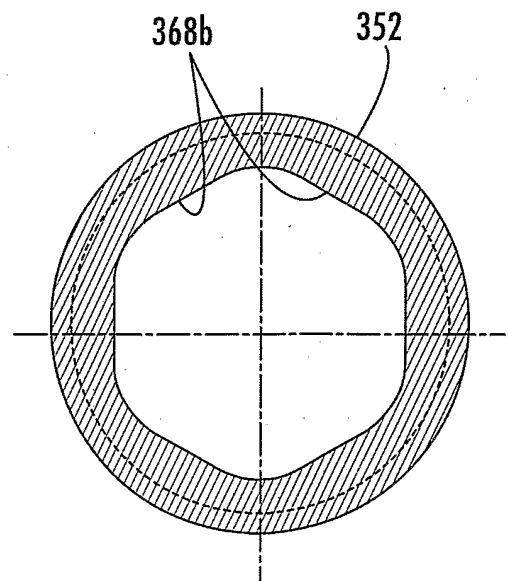

FIG. 45

31/33

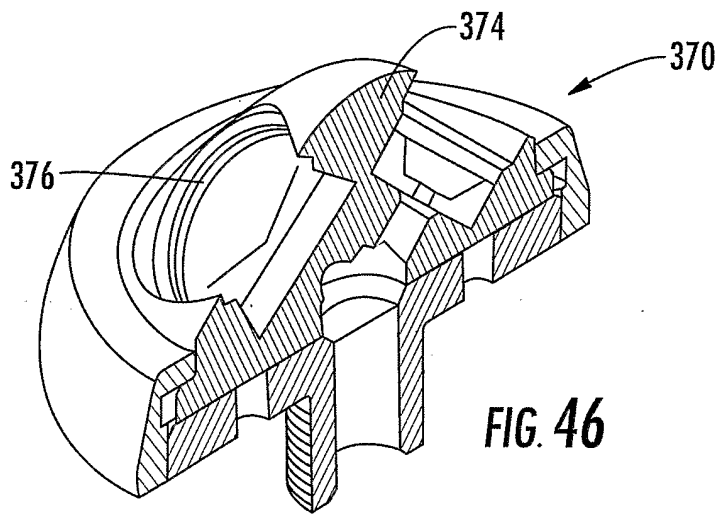

FIG. 46

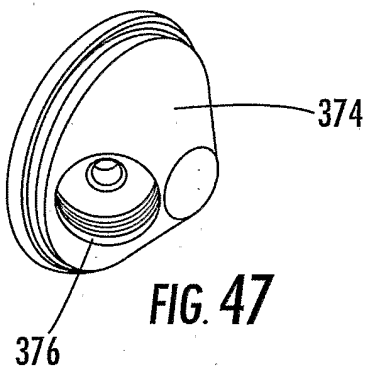

FIG. 47

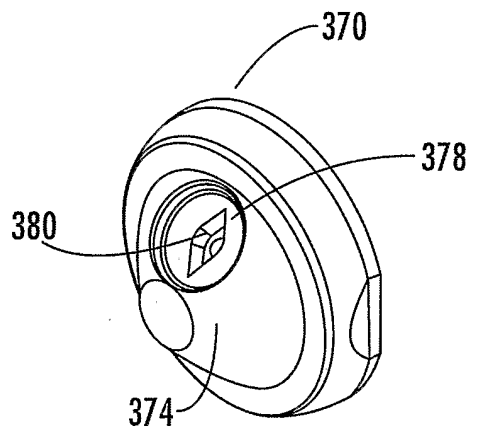

FIG. 48

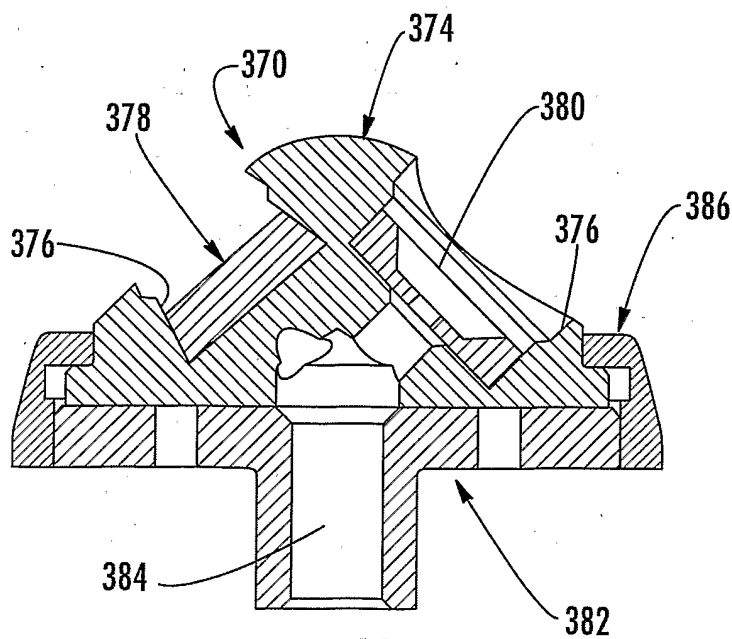

FIG. 49

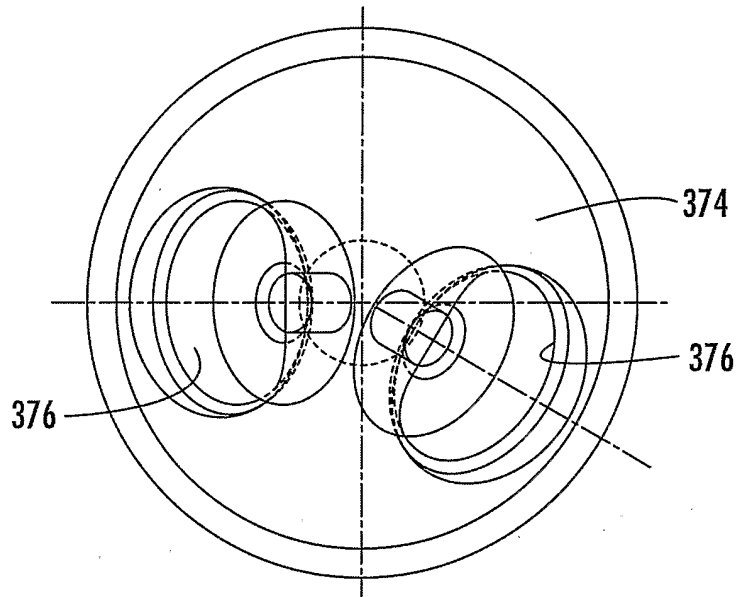

FIG. 50

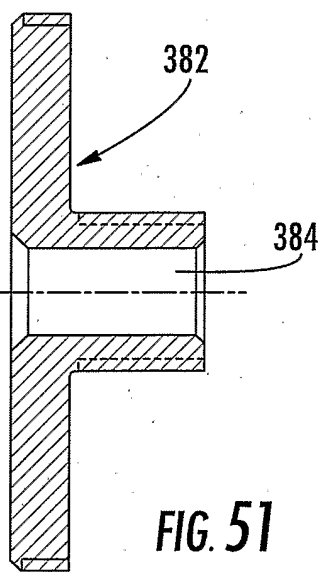

FIG. 51

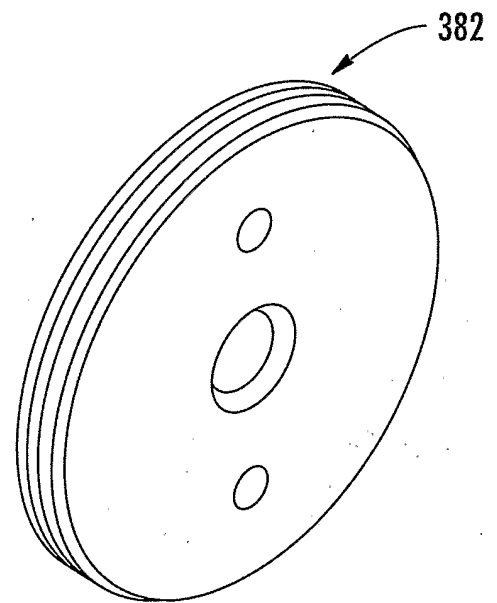

FIG. 52

33/33

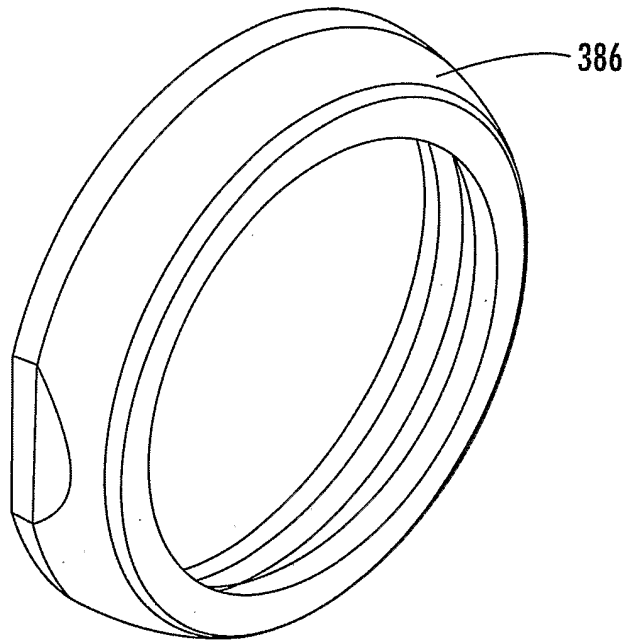

FIG. 53

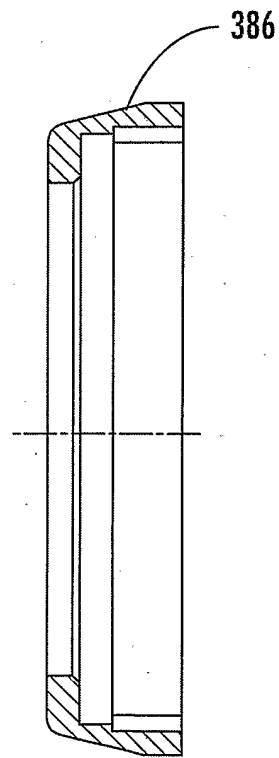

FIG. 54