

(12) PATENT
(19) AUSTRALIAN PATENT OFFICE

(11) Application No. AU 199898236 B2
(10) Patent No. 718809

(54) Title
Wrapping apparatus

(51)⁷ International Patent Classification(s)
B65B 011/28 B65B 025/14
B65B 011/30 B65B 025/24
B65B 013/22 B65B 027/06

(21) Application No: **199898236**

(22) Application Date: **1998.12.30**

(30) Priority Data

(31) Number (32) Date (33) Country
980315 1998.02.11 FI

(43) Publication Date : **1999.08.26**

(43) Publication Journal Date : **1999.08.26**

(44) Accepted Journal Date : **2000.04.20**

(71) Applicant(s)
Oy M. Haloila Ab

(72) Inventor(s)
Yrjo Suolahti

(74) Agent/Attorney
PHILLIPS ORMONDE and FITZPATRICK,367 Collins Street,MELBOURNE VIC 3000

(56) Related Art
US 4829753
US 5311725
US 5123230

(57) ABSTRACT

Wrapping apparatus for winding a wrapping foil web (F) around an object (1) to be packaged, said wrapping apparatus comprising a foil dispenser (2) arranged to circulate along a ring-like endless track (3) around the object to be packaged, which foil dispenser (2) comprises a frame (4), a detachable and replaceable foil roll (5) mounted on the frame, supporting elements (6) for supporting the foil roll on the frame, and tensioning means (7) for braking foil delivery from the roll and maintaining a predetermined foil tension. The tensioning means (7) comprise a sensor (8) for detecting foil web tension, and an electric motor (9) for driving the foil roll (5), the torque, speed of rotation and/or direction of rotation of said electric motor being controlled on the basis of foil tension as detected by the sensor.

(Fig. 2)



WRAPPING APPARATUS

The present invention relates to a wrapping apparatus.

In prior art, e.g. specification EP 0 544 312 A1
 5 presents a wrapping apparatus for winding a web of wrapping foil around an object to be packaged. Such a wrapping apparatus comprises a foil dispenser arranged to circulate along a ring-like endless track around the object to be packaged. In the prior-art apparatus the track
 10 is of a substantially elliptical form. The track comprises a straight track portion, which passes through the center hole of the cylindrical object to be packaged and the straight track portion extends outside the hole to a distance from the end of the cylindrical object. The track
 15 also comprises a curved portion which forms a curved track between the ends of the straight track portion and around the object to be packaged. The foil dispenser comprises a frame and a detachable and replaceable foil roll mounted on the frame. Furthermore, the foil
 20 dispenser comprises supporting elements for supporting the foil roll on the frame, and tensioning means for braking the delivery of foil from the roll to maintain a predetermined foil tension. A special problem which arises from said form of the track is that, during wrap-
 25 ping, in certain parts along the track, the foil span (i.e. a portion of the foil extending between a support point, e.g. edge point, of the object to be packaged and the foil dispenser) does not lengthen, but, instead, becomes shorter. Therefore the foil web would slacken if
 30 the tensioning device would not eliminate the slack. In EP 0 544 312 A1 the foil tensioning device is a complicated mechanical foil storage device comprising a number of fixedly mounted deflecting rollers, a number of flexibly mounted deflecting rollers and loading means for
 35 flexibly applying to the flexibly mounted rollers a load acting in a direction away from the fixedly mounted rollers so as to maintain tension in a variable amount of



foil web passing along a winding path around the deflecting rollers.

A problem with this prior-art apparatus is that the foil storage takes up a relatively large space in the foil dispenser. Moreover, the structure is heavy, complex and expensive. Especially in types of wrapping apparatus in which the foil dispenser should be as small as possible to be able to pass e.g. through the central hole of a foil roll, the large size of the prior-art structure leads to problems. The heavy weight again results in a necessity to use a foil dispenser drive mechanism and motor accordingly dimensioned.

The object of the present invention is to substantially eliminate one or more of the drawbacks described above. In particular it would be desirable to present a wrapping apparatus in which the foil dispenser is as simple as possible, contains few components and is light and cheap.

Accordingly, the invention provides a wrapping apparatus for winding a wrapping foil web around an object to be packaged, the wrapping apparatus including a foil dispenser arranged to circulate along a ring-like endless track around the object to be packaged, which foil dispenser includes a frame, a detachable and replaceable foil roll mounted on the frame, supporting elements for supporting the foil roll on the frame, and tensioning means for maintaining a predetermined foil tension, wherein the tensioning means includes a sensor for detecting foil web tension, and an electric motor for driving the foil roll, the torque, speed of rotation and/or direction of rotation of said electric motor being controlled on the basis of foil tension as detected by the sensor.

The invention has the advantage that, to maintain a sufficient foil tension, the foil roll can be caused to rotate in the direction of foil delivery as well as in the opposite direction as necessary according to the measured foil tension. As the inertia of the foil roll in certain situations tends to cause excessive foil delivery, the torque of the electric motor is increased or decreased as necessary in accordance with the foil tension as detected by the sensor. Also the speed of ro-

30

tation of the electric motor can be controlled. The foil dispenser contains few parts and is simple, small, light and cheap.

In an embodiment of the apparatus, the foil dispenser comprises a first diverting element, which is connected to the frame and around which the foil web drawn from the foil roll passes, said first diverting element touching the first side of the foil. A second diverting element is connected to the frame at a distance from the first diverting element, said second diverting element touching the first side of the foil. The sensor comprises a spring-loaded lever arm, a turning axle, which is supported by a bearing on the frame and to which the lever arm is attached, and a third diverting element, which is connected to the end of the lever arm between the first and second diverting elements, said third diverting element touching the second side of the foil, so that the foil web passing between the first and second diverting elements over the third diverting element, which is capable of a springing motion, forms a bend that comprises a varying length of foil web.

In an embodiment of the apparatus, the sensor comprises a potentiometer so connected to the turning axle that the resistance of the potentiometer changes as a function of the angle of rotation of the turning axle, said angle being directly proportional to the tension of the foil web, to produce a control signal for controlling the speed and direction of rotation of the electric motor.

In an embodiment of the apparatus, the electric motor is a direct-current motor.

In an embodiment of the apparatus, the supporting elements for supporting the foil roll comprise a first supporting element, which is rotatably mounted with a bearing on the frame and fitted to support the foil roll from the side of its first end face, and a second supporting element, which is fitted to support the roller

from the side of its second end face opposite to the first end face. The second supporting element comprises a drive shaft supported by a bearing on the frame. The drive shaft is driven by the electric motor.

5 In an embodiment of the apparatus, the apparatus has a first wheel, such as a belt pulley or the like, mounted on the drive shaft. Mounted on the shaft of the electric motor is a second wheel, such as a belt pulley or the like. A first endless traction means, such as a
10 belt or the like, has been arranged to run over the first and second wheels to transmit the power of the electric motor to the drive shaft.

In an embodiment of the apparatus, the apparatus has a third wheel, such as a belt pulley or the like, at-
15 tached to the turning axle. Connected to the potentiometer is a fourth wheel. A second endless traction means, such as a belt or the like, has been arranged to run over the third and fourth wheels to transmit the rotation of the turning axle into rotation of the potentiometer.

20 In an embodiment of the apparatus, the wrapping apparatus comprises a machine frame supporting a wrapping ring arranged to guide the motion of the foil dispenser. The wrapping ring comprises two ring sections movable relative to each other between two positions. These posi-
25 tions are an open position, in which the ring sections have a port opening between them, and a closed position, in which the port opening is closed and the wrapping ring forms the endless ring-like track referred to. The object to be packaged being a cylindrical body, such as a band
30 roll, having a central hole going through it, the wrapping ring in its closed position has been arranged to pass through the central hole.

In an embodiment of the apparatus, the track is of a substantially elliptical form. The track comprises a
35 straight track portion, which, in the closed position of the wrapping ring, passes through the hole in the object to be packaged and extends outside the hole to a distance

from the end of the cylindrical object, and a curved portion which forms a curved track between the ends of the straight track portion and around the object to be packaged.

5 In the following, the invention will be described in detail by the aid of a few examples of its embodiments by referring to the attached drawings, in which

Fig. 1 presents an embodiment of the apparatus of the invention,

10 Fig. 2 presents a foil dispenser in an apparatus as illustrated by Fig. 1,

Fig. 3 presents the foil dispenser of Fig. 2 as seen from the direction III-III, and

15 Fig. 4 presents a control circuit for controlling the electric motor comprised in the foil dispenser and working in conjunction with the foil roll.

Fig. 1 shows a wrapping apparatus for winding a web of wrapping foil around an object 1 to be packaged. The wrapping apparatus comprises a foil dispenser 2 arranged to circulate along an endless ring-like track 3 around the object 1 to be packaged. In the figure, the object 1 to be packaged is a roll of steel band, which rests on a base provided with a turning gear, e.g. turning rollers, so that the band roll 1 can be turned about its horizontal symmetry axis during the wrapping operation. The band roll 2 has a central hole 33 going through the roll.

The wrapping apparatus comprises a machine frame 28 supporting a wrapping ring 29, which has been arranged 30 to guide the motion of the foil dispenser 2. The wrapping ring 29 consists of two ring sections 30, 31, which are with the aid of power means 60 and 61 movable relative to each other between two positions I and II, for which purpose the ring sections 30 and 31 are supported by a horizontal guide beam 62. In the open position I, which in 35 Fig. 1 is depicted with broken lines, the ring sections 30, 31 have a port opening 32 between them. In this posi-

tion, a band roll 1 can be brought into the wrapping station. In the a closed position II, the port opening 32 is closed and the wrapping ring forms the endless ring-like track 3 referred to. The track 3 comprises a horizontal track portion 34, which in the closed position II of the wrapping ring 29 passes through the hole 33 in the object 2 to be packaged, and a curved portion 35, which, outside the hole, forms a curved track around the object to be packaged.

10 Fig. 2 and 3 illustrate the foil dispenser 2, with a removable and replaceable foil roll 5 supported on its frame 4 by means of supporting elements 6. The foil dispenser is provided with a sensor 8 for detecting foil web tension. Moreover, the foil dispenser 2 has an electric motor 9 for driving the foil roll 5. The torque of the electric motor 9 is continuously controlled on the basis of the foil tension as detected by the sensor 8 so that an appropriate foil tension is maintained, ensuring that the foil is always at a suitable tightness as it is laid onto the surface of the object being packaged. To maintain the tightness, the electric motor 9 can also drive the foil roll in the reverse direction as necessary.

20 The foil dispenser 2 comprises a first diverting element 10, which is connected to the frame 4. The foil web F drawn from the foil roll 5 passes over the first diverting element, which touches the first side 11 of the foil. A second diverting element 12 is connected to the frame 4 at a distance from the first diverting element 10. The second diverting element, too, touches the first side 11 of the foil.

25 The sensor 8 comprises a spring-loaded lever arm 13. The turning axle 14 to which the lever arm is attached is supported by a bearing on the frame 4. A third diverting element 15 is connected to the end of the lever arm 13 between the first and second diverting elements. The third diverting element touches the second side 16 of

the foil. The foil web passing between the first and second diverting elements over the third diverting element, which is capable of a springing motion, forms a bend that comprises a varying length of foil web.

5 The sensor 8 further comprises a resistance potentiometer 17, which is so connected to the turning axle 14 that the resistance of the potentiometer changes as a function of the angle of rotation of the turning axle 14, said angle being directly proportional to the tension of
10 the foil web, to produce a control signal for the electric motor 9. Attached to the turning axle 14 is a third wheel 25, such as a belt pulley or the like. A fourth wheel 26 is connected to the resistance potentiometer 17. A second endless traction means 27, such as a belt or the
15 like, has been arranged to run over the third and fourth wheels to transmit the rotation of the turning axle into rotation of the resistance potentiometer 17.

 The supporting elements 6 carrying the foil roll 5 on the frame 4 comprise a first supporting element 6¹,
20 which is rotatably mounted with a bearing on the frame 4 and fitted to support the foil roll 5 from the side of its first end face 18, and a second supporting element 6², which is fitted to support the roller from the side of its second end face 19 opposite to the first end face.
25 The second supporting element 6² comprises a drive shaft 20 supported by a bearing on the frame 4 and fitted to be driven by the electric motor 9. Mounted on the drive shaft 20 is a first wheel 21, such as a belt pulley or the like. Mounted on the shaft 22 of the electric motor 9
30 is a second wheel 23, such as a belt pulley or the like. An endless first traction means 24, such as a belt or the like, runs over the first wheel 21 and the second wheel 23 to transmit the power of the electric motor 9 to the drive shaft 20.

35 Fig. 4 presents an example of a control system that can be used to control the operation of the electric motor 9. The electric motor 9 is regulated by means of a

control card 52. The regulation comprises various states, which are controlled by a logic circuit 45. The output of the control logic circuit controls relay switches 47 - 51. The input to the logic circuit 45 is a voltage 53 obtained from the resistance potentiometer 17 and scaled to a suitable voltage range by means of circuit 43. 55, 55 and 57 are in the same potential as operating voltage.

The output of the control logic circuit 45 provides three control states:

10 1. Slack foil is rewound by causing the electric motor 9 to rotate in the direction opposite to the wrapping direction.

15 2. The foil is subjected to initial tensioning by causing the electric motor 9 to rotate in the wrapping direction.

 3. The electric motor 9 is caused to rotate at a constant speed in the wrapping direction.

20 To rewind slack foil, the control logic circuit 45 connects control relay 48 to the output of potentiometer 41, which gives a speed reference for the electric motor 9. Control relay 49 connects a control voltage 56 to the control card 52, defining that the electric motor 9 is to be rotated in the direction opposite to the wrapping direction.

25 Initial tensioning of the foil is started by connecting control relay 47 to the output of potentiometer 40, control relay 48 to the output of PID controller 46 and control relays 49 and 51 to the control voltage 56. Integrator 44 receives a control voltage from potentiometer 40, scaled to a suitable voltage range by circuit 42. From the output of the PID controller 46, the electric motor 9 receives a speed reference to be used for tensioning the foil to a reference tension. The reference tension is adjusted by means of potentiometer 40.

30 When the integrator reaches the reference tension, control relay 50 is connected to the control voltage 56, permitting foil feed.

35

The invention is not restricted to the examples of its embodiments described above, but many variations are possible within the scope of the inventive idea defined by the claims.

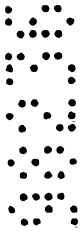

THE CLAIMS DEFINING THE INVENTION ARE AS FOLLOWS:

1. A wrapping apparatus for winding a wrapping foil web around an object to be packaged, said wrapping apparatus including a foil dispenser
5 arranged to circulate along a ring-like endless track around the object to be packaged, which foil dispenser includes a frame, a detachable and replaceable foil roll mounted on the frame, supporting elements for supporting the foil roll on the frame, and tensioning means for maintaining a predetermined foil tension, wherein the tensioning means includes a sensor for detecting foil web tension,
10 and an electric motor for driving the foil roll, the torque, speed of rotation and/or direction of rotation of said electric motor being controlled on the basis of foil tension as detected by the sensor.

2. Apparatus as defined in claim 1, wherein the foil dispenser
15 includes a first diverting element, which is connected to the frame and around which the foil web drawn from the foil roll passes, said first diverting element touching the first side of the foil, and a second diverting element, which is connected to the frame at a distance from the first diverting element, said second diverting element touching the first side of the foil; and wherein the
20 sensor includes a spring-loaded lever arm, a turning axle, which is supported by a bearing on the frame and to which the lever arm is attached, and a third diverting element, which is connected to the end of the lever arm between the first and second diverting elements, said third diverting element touching the second side of the foil, so that the foil web passing between the first and
25 second diverting elements over the third diverting element, which is capable of a springing motion, forms a bend that comprises a varying length of foil web.

3. Apparatus as defined in claim 2, wherein the sensor includes a
30 potentiometer so connected to the turning axle that the resistance of the potentiometer changes as a function of the angle of rotation of the turning axle, said angle being directly proportional to the tension of the foil web, to produce a control signal for controlling the electric motor.



4. Apparatus as defined in any one of claims 1 to 3, wherein the electric motor is a direct-current motor.

5. Apparatus as defined in claim 3 or claim 4, wherein the supporting elements for supporting the foil roll include a first supporting element, which is rotatably mounted with a bearing on the frame and fitted to support the foil roll from the side of its first end face, and a second supporting element, which is fitted to support the roller from the side of its second end face opposite to the first end face, said second supporting element including a drive shaft supported by a bearing on the frame, said drive shaft being driven by the electric motor.

6. Apparatus as defined in claim 5, wherein it has a first wheel, such as a belt pulley or the like, mounted on the drive shaft; wherein it has a second wheel, such as a belt pulley or the like, mounted on the shaft of the electric motor; and wherein it has a first endless traction means, such as a belt or the like, arranged to run over the first and second wheels to transmit the power of the electric motor to the drive shaft.

7. Apparatus as defined in any one of claim 6, wherein it has a third wheel, such as a belt pulley or the like, attached to the turning axle; wherein it has a fourth wheel connected to the potentiometer; and wherein it has a second endless traction means, such as a belt or the like, arranged to run over the third and fourth wheels to transmit the rotation of the turning axle into rotation of the potentiometer.

8. Apparatus as defined in any one of claims 1 to 7, wherein the wrapping apparatus includes a machine frame supporting a wrapping ring arranged to guide the motion of the foil dispenser, said wrapping ring including two ring sections moveable relative to each other between two positions, an open position, in which the ring sections have a port opening between them, and a closed position, in which the port opening is closed and the wrapping ring forms the endless ring-like track referred to; and wherein the object to be



packaged is a cylindrical body, such as a band roll, that has a central hole going through it; and wherein the wrapping ring in its closed position has been arranged to pass through the central hole.

5 9. Apparatus as defined in claim 8, wherein the track is of a substantially elliptical form, and that the track includes a straight track portion, which, in the closed position of the wrapping ring, passes through the hole and extends outside the hole to a distance from the end of the cylindrical object, and a curved portion which, outside the hole, forms a curved track between the
10 opposite ends of the straight track portion and around the object to be packaged.

15 10. Wrapping apparatus for winding a wrapping foil web around an object to be packaged, substantially as hereinbefore described with reference to the accompanying drawings.

DATED: 23 December, 1998

PHILLIPS ORMONDE & FITZPATRICK

20 Attorneys for:

OY M. HALOILA AB

David B Fitzpatrick

Fig. 2

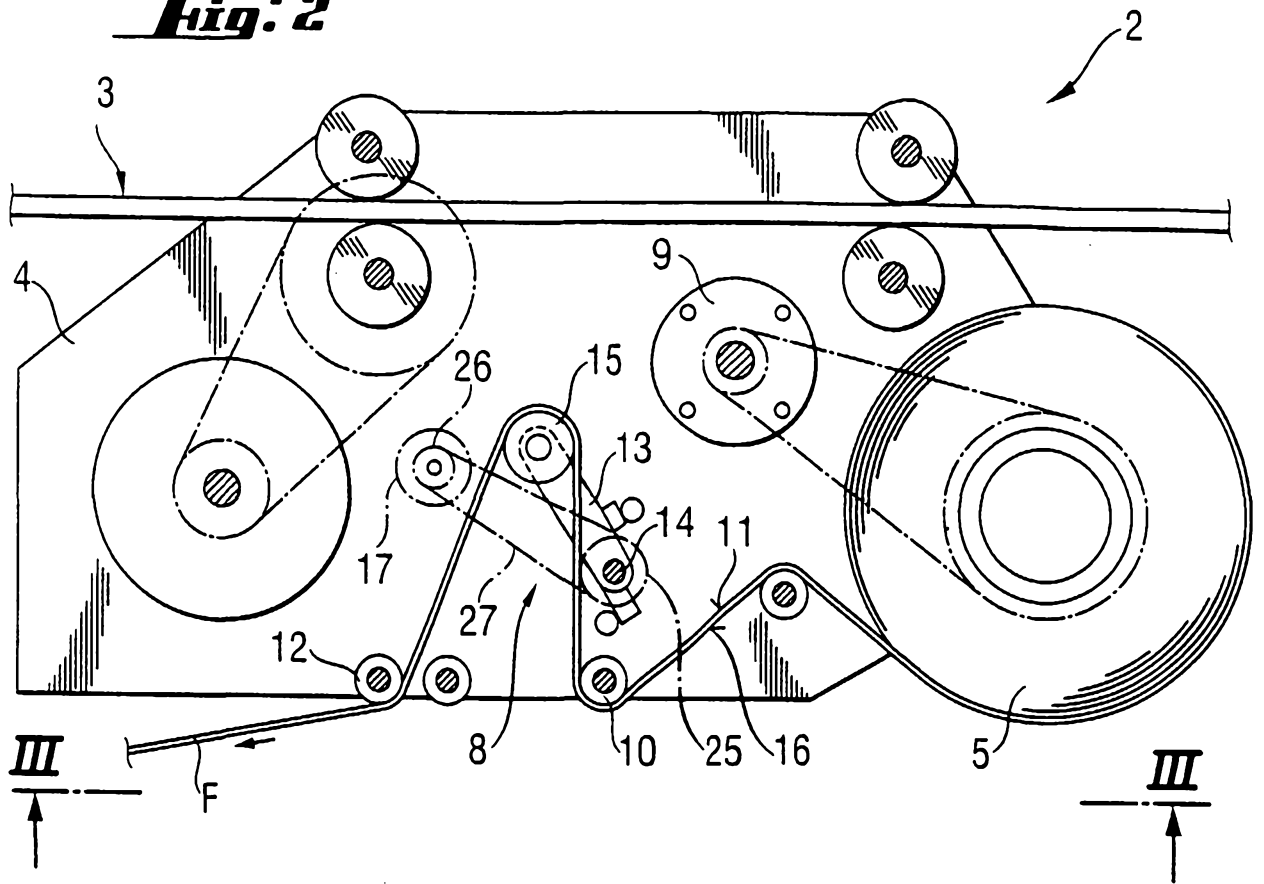
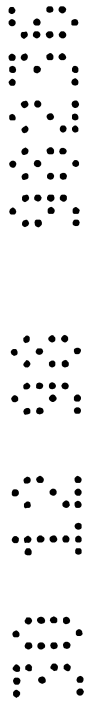
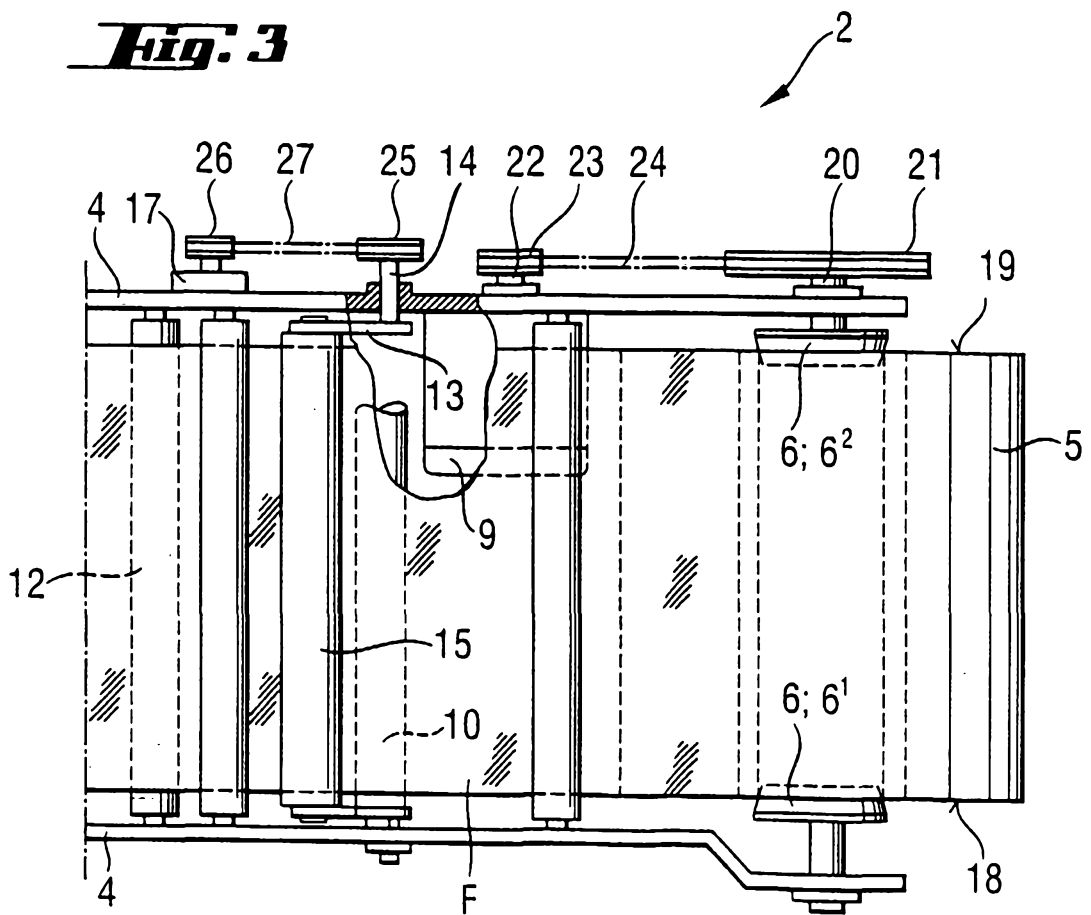

Fig. 3



30 12 00 80208

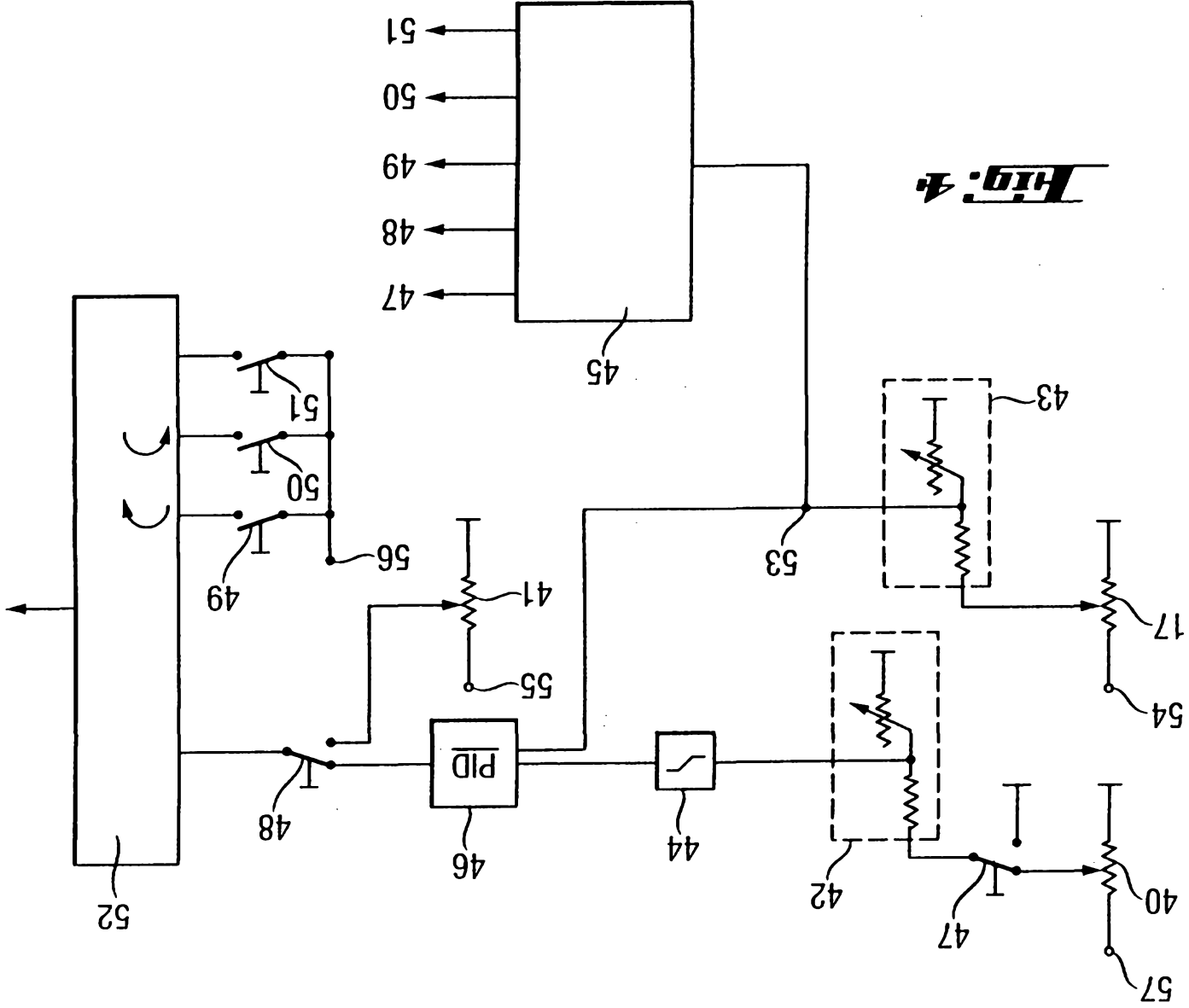

Fig. 4