



⑫

**EUROPEAN PATENT APPLICATION**

⑰ Application number : **92401158.8**

⑸ Int. Cl.<sup>5</sup> : **F41A 3/14, F41A 3/72,  
F41A 3/64**

⑱ Date of filing : **23.04.92**

⑳ Priority : **01.05.91 US 694194**

⑺ Inventor : **Ruger, William B.**  
**Croydon Turnpike**  
**Croydon, New Hampshire 03773 (US)**

㉓ Date of publication of application :  
**04.11.92 Bulletin 92/45**

⑻ Representative : **Hirsch, Marc-Roger et al**  
**Cabinet Hirsch 34 rue de Bassano**  
**F-75008 Paris (FR)**

⑻ Designated Contracting States :  
**AT BE CH DE ES GB LI**

⑺ Applicant : **STURM, RUGER & COMPANY, INC.**  
**Lacey Place**  
**Southport Connecticut 06490 (US)**

⑼ Reinforced slide configuration for automatic pistol.

⑻ Reinforcement elements are attached to the exterior surface of the slide of an automatic weapon to prevent cracking of the slide at its most vulnerable locations.

## Background of the Invention

Slides for automatic pistols have included sides of varying thicknesses to accomplish desired appearances and for structural or other reasons. Automatic pistols must have their slides manually retracted to chamber the first cartridge to be fired; and it is also necessary to manually retract the slide to unload a chambered cartridge. Pistol slides are therefore customarily equipped with grasping grooves for facilitating manual retraction.

The sides of some pistol slides have included cut-out or notched areas for effecting the proper location of the slide to the barrel during firing of the cartridge, and unlocking of these parts during recoil to allow cycling of the slide to expend spent cartridge cases and to effect reloading. Reciprocating slides have included techniques for accepting pivoting locking mechanisms which alternately lock and unlock the barrel slide. Such mechanisms for locking and unlocking the barrel and slide have included recesses formed in the interior of the slide which recesses inherently weakened the structure of the slide.

Slide previously used or proposed which include these locking recesses at thin sections of the slide have not been found to be satisfactory for extended and demanding use.

## Summary of the Invention

Broadly, this invention comprises an automatic pistol slide reinforced at its central exterior portion through adding a configured thickness to the sides of a slide in selected areas. Preferably, the reinforced elements of the slide are sufficient in thickness to accommodate gripping serrations without weakening the strength of the reinforced slide sides.

It is a feature that the reinforcing of the slide sides can be integrally formed in the slide as cast, forged or otherwise fabricated.

This application is a continuation-in-part of U.S. Application Serial No. 07/580,739 filed September 11, 1990 which in turn is a continuation of U.S. Application Serial No. 07/205,717, filed June 13, 1988, both entitled ""Reinforced Slide Configuration For Automatic Pistol".

## Brief Description of the Invention

Fig. 1 is a side elevational view of an automatic pistol including the present invention;  
 Fig. 2 is a plan view of the pistol;  
 Fig. 3 is a side elevational view of the pistol with its slide retracted;  
 Fig. 4 is an enlarged sectional view along line 4-4 of Fig. 1;  
 Fig. 5 is a side elevational view of an alternative embodiment of the invention; and

Fig. 6 is a plan view of the inventive alternative.

## Description of the Preferred Embodiment

In the figures, pistol 10 includes frame 11, barrel 12, slide 13 including upper slide portion 14, left side 15 and right side 17. Also shown are handle 18, trigger guard 19, trigger 21, hammer 22, and sights 23a, 23b. Sides 15, 17 include forward and rearward sections 15a, 15b, 17a, 17b and central portions 15c, 17c with less vertical depth than sections 15a, 15b, 17a, 17b.

The pistol barrel-slide locking mechanism includes barrel locking lugs 26a, 26b mounted on the exterior of the barrel 123 which are, at firing, housed in configured recesses 27a, 27b in slide sides 15, 17, respectively. When slide 13 is in its forward firing locked position barrel lugs 26a, 26b operate in recesses 27a, 27b to lock barrel 12 and slide 13 together (Fig. 2). As the slide 13 retracts, lugs 26a, 26b rotate out of recesses 27a, 27b freeing slide 13 for further rearward movement to its fully retracted position. Recesses 27a, 27b are formed with vertical planar recess ends 28a-d and vertical planar recess wall 29a, 29b whose intersections form corners 31a-d.

Recesses 27a, 27b have a size such that the minimum thickness of the slide sides 15, 17 is about 1/8 inch or less. To reinforce slide 13 at and near each recess 27a, 27b, reinforcing raised slide side portions 34, 36 are located on the slide sides 15, 17 extending forward and rearwardly of the recesses 27a, 27b to provide sufficient thickness of material in the slide recess corner areas 31a-d and beyond to add to the strength in such areas and to reduce the likelihood of cracking or breaking of slide 13 after extending firing and cycling of the pistol barrel and slide.

Reinforcing portions 34, 36 preferably are about 1/8" thick, though their thickness, length and vertical depth may vary depending on the size of the internal slide recesses 27a, 27b. Reinforcing portions 34, 36 may be manufactured as an integral part of the slide or as separate pieces welded to slide 13 or otherwise attached. Reinforcing portions 34, 36 of about one-third the length of slide 13 are preferred but they may be longer or shorter.

Reinforcing portions 34, 36 carry grip indentations 38 and projections 39 forming angled grip serrations 40. Portion 34 or 36 may also be notched on its lower side for an external slide stop notch, if necessary.

Finally turning to Fig. 5, an alternative embodiment is shown in which reinforcing portions 34', and 36' are different in size and shape. Portion 34' has a vertical depth (vd) which is less than the vertical depth of side section 15c', includes forward portion 34a' with indentations 38' and projections 39' forming angled grip serrations 40'. Reinforcing portion 34' also has a rearward tapering non-grip portion 34b'. Forward portion 34a' is sloped at angle  $\theta$  the barrel axis forming

the front surface of serrated grip portion 34a' (Fig. 6). From the thickest point P of portion 34' rearward is trailing portion 34b'.

Recesses 27a', 27b' are reinforced by portions 34', 36' to provide greater strength in the vicinity of recesses 27a', 27b'. Reinforced portions 34', 36' are positioned vis-a-vis the recesses 27a', 27b' they reinforce and do not need to extend to either end of slide 15' since such ends are distant from the recesses. Reinforcing portions 34', 36' are longer horizontally than recesses 27a', 27b' respectively. Normally reinforcing portions 34', 36' extend from about 1/4 to 1/3 the length of the slide but may be outside that range. Forward point M is in the range of one inch forward of recess 27a' and point N is the same magnitude of distance rearward of recess 27a'. Similarly, since recesses 27a', 27b' have small vertical depths the reinforcing portions 34', 36' require vertical depths only of a magnitude to be greater than the recess depths for proper reinforcement. The vertical depth of portions 34', 36' maybe less than the central section 15c' of the side of the slide 15'.

**Claims**

- 1. In an automatic pistol having a barrel, and a retractable slide which said slide has an upper portion and two sides each having a central side portion each of which said central side portion includes an internal recess and an exterior surface and a locking mechanism for locking the barrel with respect to the slide, the improvement comprising an external, reinforcing element raised on the exterior surface of the side portion of said slide which said external reinforcing elements extend a distance less than an entire length of the slide side and is positioned adjacent to the internal recess in the said side to reinforce the slide section including such internal recess.
- 2. The improvement of claim 1 in which each said reinforcing element has an operator-hand gripping element formed in said external reinforcing element.
- 3. The improvement of claim 1 in which each said central side portion has a vertical depth and a selected length with each said reinforcing element extending vertically a portion of the depth of the said side portion and extends horizontally about one-third of the length of the slide side.
- 4. In an automatic pistol having a barrel, and a retractable slide which said slide has an upper portion and two side portions each of which said side portions include an internal recess and an exterior surface and a locking mechanism for locking

5

10

15

20

25

30

35

40

45

50

55

the barrel with respect to the slide, the improvement comprising an external reinforcing element including a forward portion with a sloping front surface having serrations and a tapering rearward portion, such reinforcing element raised on the exterior surface of a side portion of said slide which said external reinforcing element including forward and rearward portions extends a distance less than an entire length of the slide side and is positioned adjacent to the internal recess in the said side to reinforce the slide with the reinforcing element extending a substantial distance forward and a substantial distance rearward of the internal recess.

- 5. The improvement of claim 4 in which each side has a reinforcing element.
- 6. The improvement of claim 4 in which each said reinforcing element has serrated operator-hand gripping element formed on said external reinforcing element.
- 7. The improvement of claim 4 in which each said side portion has a vertical depth and a selected length with each said reinforcing element extending vertically a portion of the depth of the said side portion and extends horizontally about one-third of the length of the slide side.
- 8. The improvement of claim 4 in which said internal recess has a selected vertical depth and in which each said side portion has a vertical depth and a selected length with each said reinforcing element extending vertically a distance greater than the depth of the internal recess and the reinforcing element extends horizontally a portion of the length of the slide side.

FIG. 1

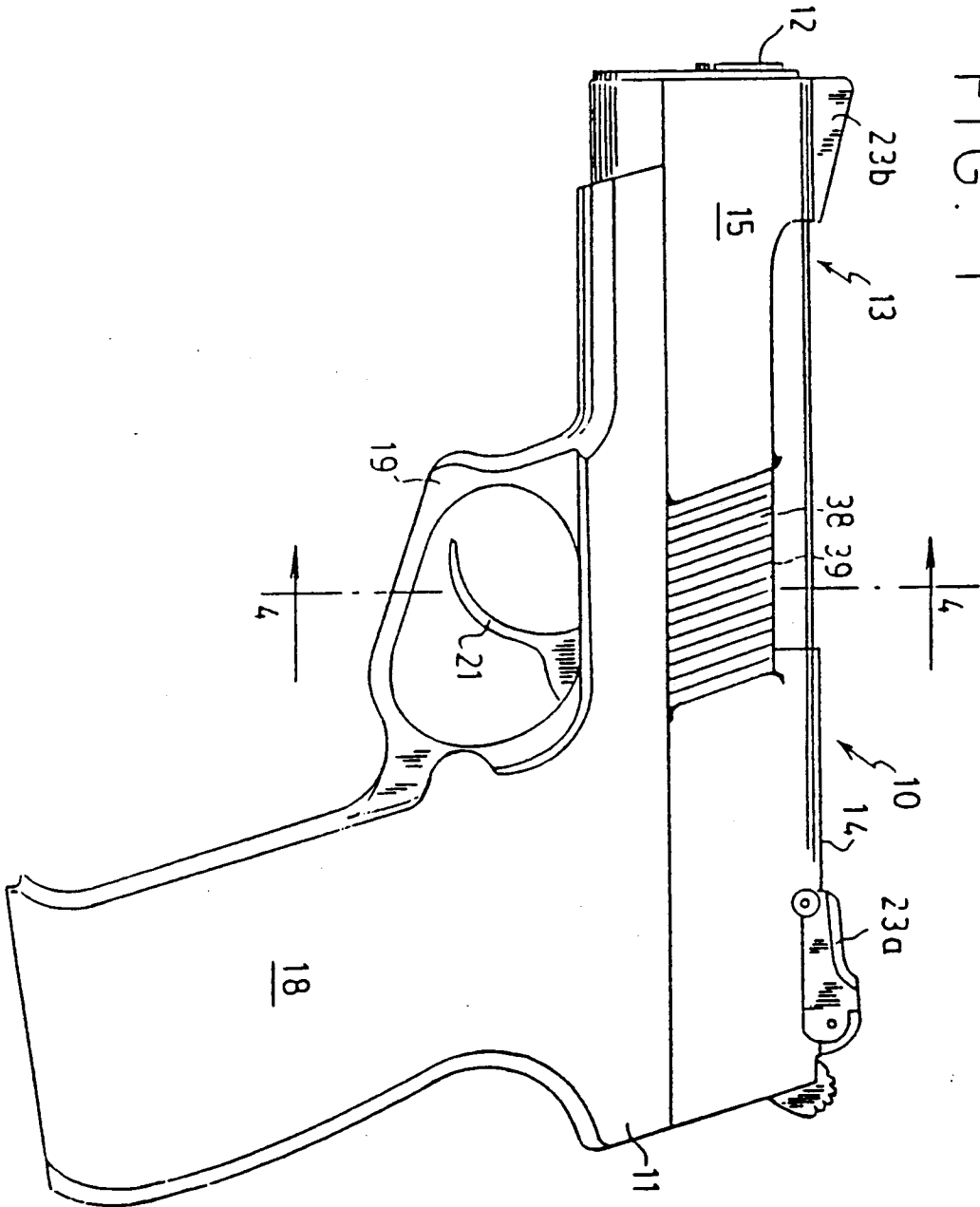

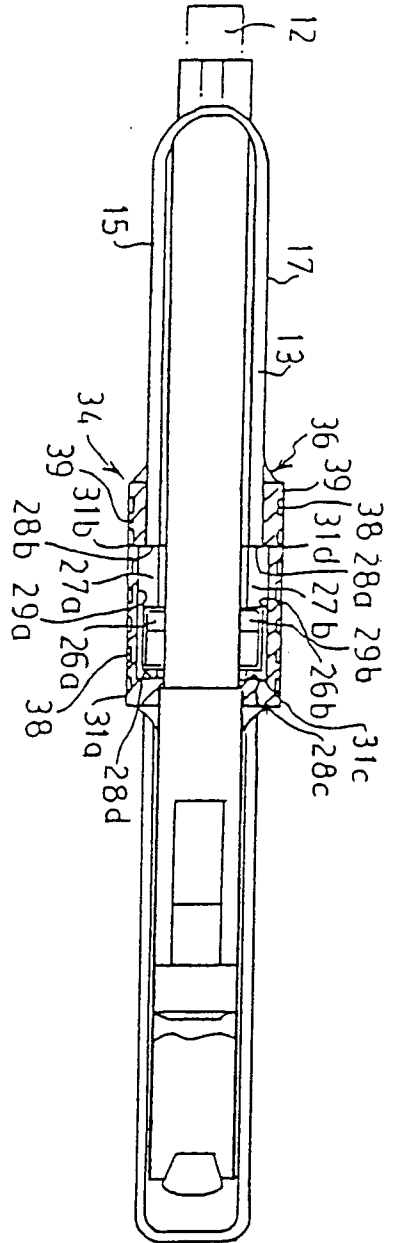

FIG. 2

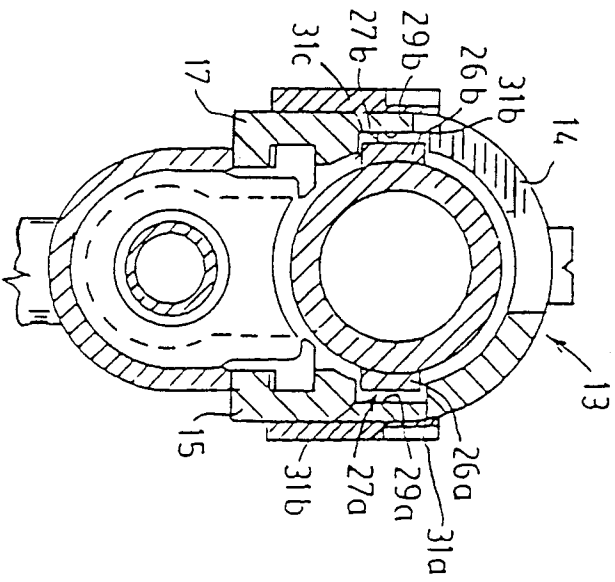
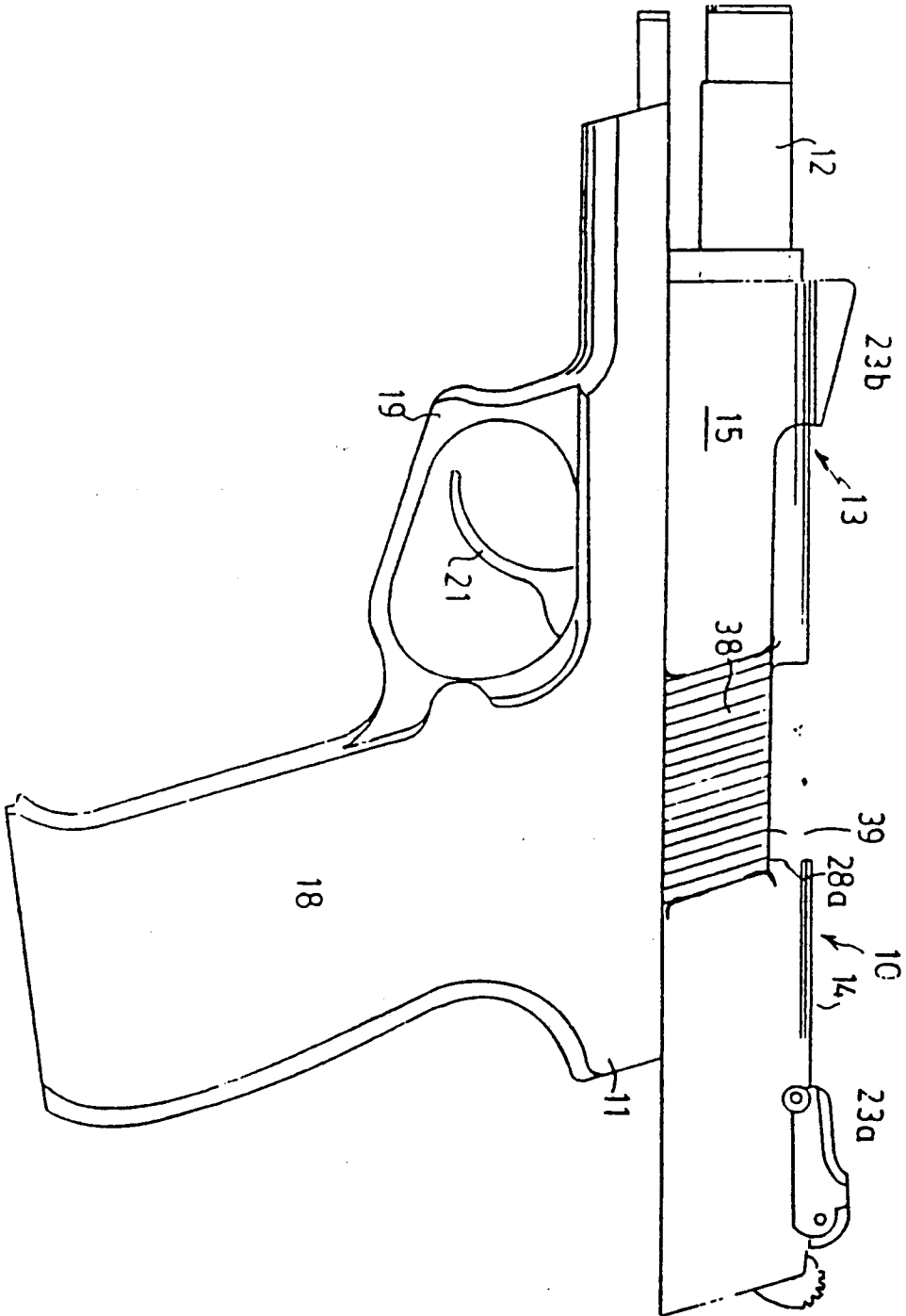
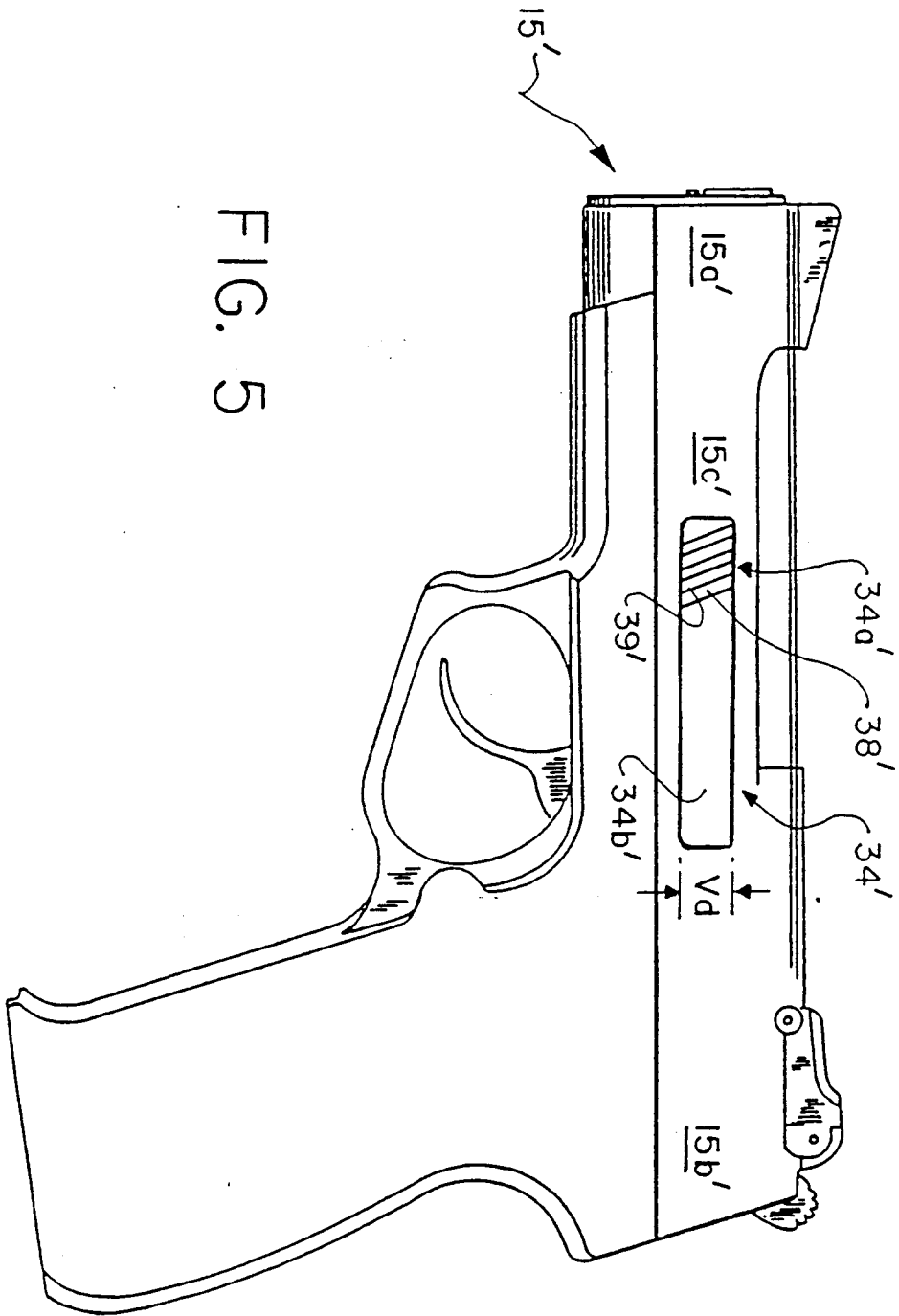

FIG. 4

FIG. 3





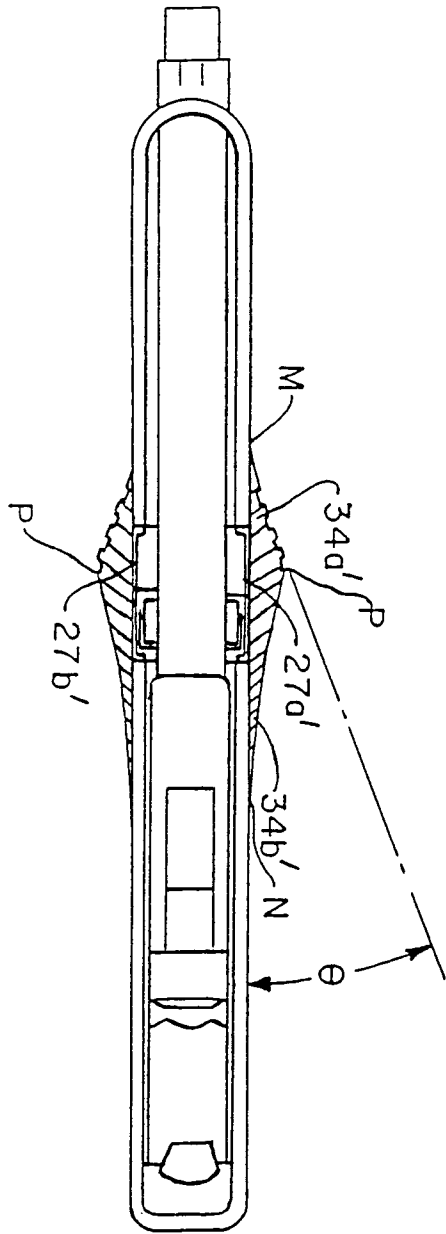

FIG. 6