



- (51) International Patent Classification:
B01F 3/04 (2006.01)
- (21) International Application Number:
PCT/US2016/014468
- (22) International Filing Date:
22 January 2016 (22.01.2016)
- (25) Filing Language: English
- (26) Publication Language: English
- (30) Priority Data:
14/603,511 23 January 2015 (23.01.2015) US
- (71) Applicant: **TECHNIP PROCESS TECHNOLOGY, INC.** [US/US]; 11740 Katy Freeway, Houston, TX 77079 (US).
- (72) Inventors: **KURUKCHI, Sabah**; 11740 Katy Freeway, Houston, TX (US). **KING, Kenneth, Edward**; 11740 Katy Freeway, Houston, TX (US). **FEWEL, Kenneth, Jack**; 11740 Katy Freeway, Houston, TX (US).
- (74) Agents: **FALLON, Peter, J.** et al.; Locke Lord LLP, Brookfield Place, 200 Vesey Street, 20th Fl., New York, NY 10281-2102 (US).

- (81) Designated States (*unless otherwise indicated, for every kind of national protection available*): AE, AG, AL, AM, AO, AT, AU, AZ, BA, BB, BG, BH, BN, BR, BW, BY, BZ, CA, CH, CL, CN, CO, CR, CU, CZ, DE, DK, DM, DO, DZ, EC, EE, EG, ES, FI, GB, GD, GE, GH, GM, GT, HN, HR, HU, ID, IL, IN, IR, IS, JP, KE, KG, KN, KP, KR, KZ, LA, LC, LK, LR, LS, LU, LY, MA, MD, ME, MG, MK, MN, MW, MX, MY, MZ, NA, NG, NI, NO, NZ, OM, PA, PE, PG, PH, PL, PT, QA, RO, RS, RU, RW, SA, SC, SD, SE, SG, SK, SL, SM, ST, SV, SY, TH, TJ, TM, TN, TR, TT, TZ, UA, UG, US, UZ, VC, VN, ZA, ZM, ZW.
- (84) Designated States (*unless otherwise indicated, for every kind of regional protection available*): ARIPO (BW, GH, GM, KE, LR, LS, MW, MZ, NA, RW, SD, SL, ST, SZ, TZ, UG, ZM, ZW), Eurasian (AM, AZ, BY, KG, KZ, RU, TJ, TM), European (AL, AT, BE, BG, CH, CY, CZ, DE, DK, EE, ES, FI, FR, GB, GR, HR, HU, IE, IS, IT, LT, LU, LV, MC, MK, MT, NL, NO, PL, PT, RO, RS, SE, SI, SK, SM, TR), OAPI (BF, BJ, CF, CG, CI, CM, GA, GN, GQ, GW, KM, ML, MR, NE, SN, TD, TG).

Published:
— with international search report (Art. 21(3))

[Continued on next page]

(54) Title: GAS DISTRIBUTOR FOR HEAT EXCHANGE AND/OR MASS TRANSFER COLUMN

FIG. 1A

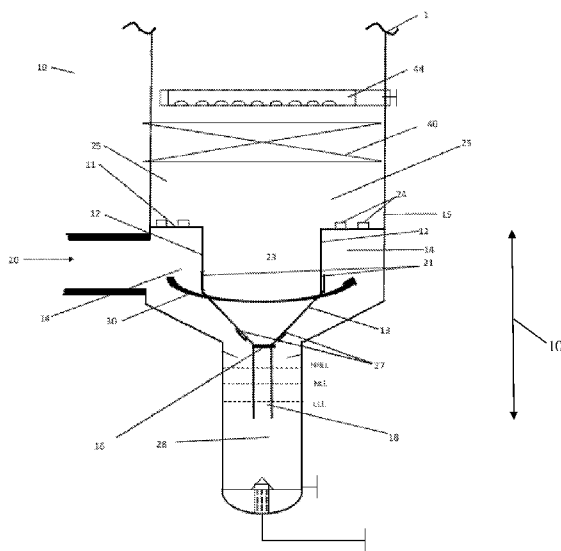

(57) Abstract: The present invention relates to a device that conditions high entrance velocity, superheated feed gas, which include some high boiling components, for example, asphaltenes and poly-nuclear aromatics that tend to coke upon condensation and exposure to the superheated feed gas temperature. Also included in superheated feed gas are solid catalyst fines, from a single or multiple feed nozzles to a quiescent flow regime for uniform distribution of the gases, to a contact device within the Main Fractionator (MF) column.



- *before the expiration of the time limit for amending the claims and to be republished in the event of receipt of amendments (Rule 48.2(h))*

GAS DISTRIBUTOR FOR HEAT EXCHANGE AND/OR MASS TRANSFER COLUMN

TECHNICAL FIELD

[0001] The present invention relates generally to a gas distributor of “F-Flute” design that provides uniform gas flow in a heat exchange and/or mass transfer column, and specifically to a gas distributor that provides uniform gas flow to the trays or packing of a Main Fractionator (MF) column in a fluid catalytic cracking unit (FCCU) facility.

BACKGROUND

[0002] Providing uniform vapor distribution in high capacity fractionation towers is one of the most challenging aspects of designing a high performance column. Conventional devices within the industry have attempted to evenly distribute the inlet feed gas to the section directly above the feed nozzle in MF columns. For example, the Vapor Horn and the Schoepentoeter, are proprietary vapor inlet horn and vane type inlet devices, respectively, which introduce gas/liquid mixtures into a vessel or column. However, these devices proved to be problematic because as the feed gas cools inside both devices, the heaviest components, e.g., asphaltenes, start condensing and deposit or stick to the cool surfaces of the apparatus. With further and continuous contact of the hot feed gas there is stripping of the lighter material from the deposit, as well as stripping of hydrogen atoms from the polymerized asphaltenes causing it to turn to coke. With time, the coke deposit grows to significant size and caused interference with the flow of gas and, as a result, the devices have to be taken out of the MF columns.

[0003] Typical prior art devices that have tried to address the problem of ensuring good mixing and even distribution are disclosed in the following: U.S. Patent No. 8,286,952 to Lee et al. discloses a vapor distributor for gas-liquid contacting column; U.S. Patent No. 8,025,718 to Kooijman et al. discloses a Fluid Inlet Device; U.S. Patent No. 7,744,067 to Kurukchi et al. discloses a three phase vapor distributor; U.S. Patent No. 7,459,001 to Christiansen et al. discloses a vane diffuser; U.S. Patent No. 7,281,702 to Jacobs et al. discloses methods and an apparatus for mixing and distributing fluids; U.S. Patent No. 7,104,529 to Laird et al. describes a

vapor distributor apparatus, the vapor horn of which includes a series of vanes the sizes of which increase with distance from the inlet nozzle of the vapor distributor; U.S. Patent No. 6,997,445 discloses a method and device for introducing a liquid-vapor mixture into a radial feed cylindrical fractionating column; U.S. Patent No. 6,948,705 to Lee et al. describes a gas-liquid contacting apparatus in which a gas stream, for example steam, is fed into a column via an annular vapor horn; U.S. Patent No. 6,889,961 to Laird et al. described a modified vapor distributor with baffles in the lower intermediate transitional section to reduce swirling of the feed and thereby improve distribution; U.S. Patent No. 6,889,962 to Laird et al. disclosed an annular inlet vapor horn that circulates the inlet feed so as to de-entrain any liquid droplets while providing for more even distribution of the inlet flow across the column; U.S. Patent No. 6,309,553 to Lanting et al. discloses a phase separator having multiple separation units, upflow reactor apparatus, and methods for phase separation; U.S. Patent No. 6,341,765 to Moser discloses a method for the infeed of a fluid into an apparatus; U.S. Patent No. 5,632,933 to Yeoman et al. describes an annular bi-directional gas flow device having a plurality of outlets at an inner wall of the housing and a series of flow directing vanes for distribution of an inlet vapor stream across the breadth of a column; U.S. Patent No. 5,605,654 to Hsieh et al. disclosing a vapor distributor having an annular housing with a series of ports for feeding the vapor stream in a distributed manner; U.S. Patent No. 5,558,818 to Gohara et al. discloses a wet flue gas scrubber having an evenly distributed flue gas inlet; U.S. Patent No. 5,632,933 to Yeoman discloses a method and apparatus for vapor distribution in mass transfer and heat exchange columns; U.S. Patent No. 5,106,544 to Lee et al., which describe a combination of an inlet horn having a 360 degree annular housing with directional flow vanes; U.S. Patent No. 4,435,196 to Pielkenrood discloses a multiphase separator for treating mixtures of immiscible gaseous, liquid and/or solid components, comprising a gas-tight and pressure-proof tank; U.S. Patent No. 3,651,619 to Miura discloses an apparatus for the purification of gas; and U.S. Patent No. 3,348,364 to Henby discloses a gas scrubber with a liquid separator.

[0004] Some other prior art devices that have tried to address the above-referenced problems include the following: U.S. Published Application 2005/0146062 to Laird et al. discloses a method and apparatus for facilitating uniform vapor distribution in mass transfer and heat exchange columns; U.S. Published Application 2005/0029686 to Laird et al. discloses a

fluid stream feed device for a mass transfer column; and U.S. Published Application 2003/0188851 to Laird et al. discloses a method and apparatus for uniform distribution in mass transfer and heat exchange columns.

[0005] Additional prior art references in this regard include: McPherson, L.J.: "Causes of FCC Reactor Coke Deposits Identified"; O&GJ, September 10, 1984, pp 1 39; NPRA Question and Answer Session, 1986, (Transcripts) Heavy Oil Processing, Question 12, pp 45; Lieberman, N.P.: "Shot Coke: its origins and prevention"; O&GJ, July 8, 1985. pp 45; Christopher Dean et.al. "FCC Reactor Vapor Line Coking," Petroleum Technology Quarterly Autumn 2003; Christopher Dean et.al. "Process Equipment Specification and Selection," Petroleum Technology Quarterly Autumn 2004; Hanson D.W. et.al. "De-Entrainment and Washing of Flash-Zone Vapor in Heavy Oil Fractionators," HCP, July 1999, 55-60; Scott W. Golden et.al. "Correcting Design Errors can Prevent Coking in Main Fractionators," Oil & Gas J. Nov. 21, 1994, 72-82; Dana G. Laird. "Benefit of Revamping a Main Fractionator," Petroleum Technology Quarterly; Winter 2005. David Hunt et.al.; "Minimizing FCC Slurry Exchanger Fouling," Petroleum Technology Quarterly Winter 2008; Mark Pilling et.al.; "Entrainment Issues in vacuum Column Flash Zones," Petroleum Technology Quarterly; Winter 2010.

[0006] It is worth noting that in the majority of devices utilizing a vapor horn the inlet flow is unidirectional with a cyclonic effect on the vapor feed. In these types of devices, baffles or vanes are used to redirect or disrupt the circular flow of the inlet stream.

[0007] As such, it would represent an advancement in the state of the art and resolve a long felt need in the art if a gas distributor device that could cool the high velocity superheated feed gas to the MF column and distribute it evenly to the bottom of the slurry packed section without fouling and coke deposition inside the feed distributor device.

SUMMARY OF THE INVENTION

[0008] The present invention is directed to a gas distributor for a heat exchange and/or mass transfer column. The gas distributor is located within the column and comprises at least

one feed gas inlet nozzle extending through a shell wall of the column for directing a feed gas to a substantially vertical interior cylindrical deflector wall comprising at least one opening to an annular interior open area within the gas distributor. The gas distributor further contains a bottom section that extends the interior cylindrical deflector wall and conforms to the contour of the shell wall. The bottom section comprises an opening to a column sump within the column, and there is a generally horizontal ceiling above the feed gas inlet nozzle between the interior cylindrical deflector wall and the column shell that defines a generally circumferential gas flow channel formed between the shell wall and the interior cylindrical deflector wall, said ceiling comprises at least one opening.

[0009] Additionally, the present invention is directed to a method for distributing feed gas in a heat exchange and/or mass transfer column. The method comprising the steps of: delivering a superheated feed gas through a feed gas inlet nozzle that extends through a shell wall of the column into a generally circumferential gas flow channel formed between the shell wall, an interior cylindrical deflector wall having a bottom section and at least one opening to an annular interior open area within the column, and a ceiling above the inlet nozzle between the shell wall and the interior cylindrical deflector wall said ceiling having a plurality of openings; cooling the superheated feed gas by contacting the gas with a counter current flow of liquid as the liquid passes through the plurality of openings in the ceiling and into the circumferential gas flow channel; wetting the interior cylindrical deflector wall and an interior side of the shell wall that forms the circumferential gas flow channel with the counter current flow of liquid after the liquid has passed through the plurality of ceiling openings; and venting the superheated feed gas to an area above the ceiling and the annular interior area within the column through the at least one opening of the interior cylindrical deflector wall and the plurality of openings in the ceiling to provide a substantially uniform distribution of the superheated feed gas within the column.

[00010] The claimed gas distributor is of a simple design and easily may be installed in a column to provide uniform horizontal and vertical distribution of gas entering the column. The presently claimed F-Flute gas distributor advantageously provides for: cooling of the superheated reactor multiphase feed gas inside the F-Flute gas distributor by intimate contact with the showering slurry liquid from the F-Flute gas distributor ceiling; immediate reduction of

the feed gas temperature to reduce the possibility of high skin temperature of the main fractionator shell above its design temperature; the F-Flute gas distributor reduces the distance required between the feed nozzle and the slurry packed section by about 2.5 meters or more, and a shorter overall tower T-T length; using the F-Flute gas distributor in revamps is a cost effective alternative to increasing the size of both the feed nozzle and refractory lined gas transfer line; the fully wetted F-Flute gas distributor internals prevent dry hot spots that cause coke deposition and growth; the elimination of gas maldistribution to the slurry packed section, helps to distribute the liquid over the packing more evenly and results in more effective heat transfer in the slurry section, which results in shorter required slurry packed section length; and even gas distribution in the slurry packed section reduces entrainment of slurry liquid to the oil wash section, and may eliminate the need for the oil wash section all together.

BRIEF DESCRIPTION OF THE DRAWING

[00011] The patent application file contains at least one drawing executed in color. Copies of this patent or patent application publication with color drawings will be provided by the Office upon request and payment of the necessary fee.

[00012] FIG. 1A is a cross-section view of an embodiment of the claimed gas distributor having an F-Flute design depicted generally within a column for heat exchange and/or mass transfer.

[00013] FIG. 1B is an isometric 3D view of the F-Flute gas distributor and displays an embodiment of the invention having perforated flat plate ceiling sections and perforated flat plate with chimneys and high hats ceiling sections, as well as the interior cylindrical deflector wall segments, vent windows, and the bottom section that extends the interior cylindrical deflector wall.

[00014] FIG. 1C is a 3D view of the perforated flat plate with chimneys and high hats ceiling section of an embodiment of the claimed F-Flute gas distributor.

[00015] FIG. 2A is a 3D view of the rod-plate ceiling section of an embodiment of the

claimed F-Flute gas distributor.

[00016] FIG. 2B is an isometric 3D view of the F-Flute gas distributor and displays an embodiment of the invention having rod-plate ceiling sections, as well as the interior cylindrical deflector wall segments, vent windows, and the bottom section that extends the interior cylindrical deflector wall.

[00017] FIG. 3A is a 3D view of the perforated flat-plate ceiling section of an embodiment of the claimed F-Flute gas distributor.

[00018] FIG. 3B is an isometric 3D view of the F-Flute gas distributor and displays an embodiment of the invention having perforated flat-plate ceiling sections, as well as the interior cylindrical deflector wall segments, vent windows, and the bottom section that extends the interior cylindrical deflector wall.

[00019] FIG. 4A is a 3D view of the perforated corrugated plate ceiling section of an embodiment of the claimed F-Flute gas distributor.

[00020] FIG. 4B is an isometric 3D view of the F-Flute gas distributor and displays an embodiment of the invention having perforated corrugated plate ceiling sections, as well as the interior cylindrical deflector wall segments, vent windows, and the bottom section that extends the interior cylindrical deflector wall.

[00021] FIG. 5 is a graphic representation of the superheated feed gas and slurry liquid temperature (C°) and the superheated feed gas and liquid flow rate in kg/hr at the packing inlet, gas distributor outlet (i.e., flute outlet), and gas distributor inlet (i.e., flute inlet).

[00022] FIG. 6 is a graphic representation of the cost ratio for revamping three different size main fractionator towers, i.e., a 37KBPD system, a 90KBPD system, and 125KBPD system with twin ducts, with the presently claimed F-Flute gas distributor.

[00023] FIG. 7 illustrates a color computational fluid dynamics simulation of gas distribution velocity magnitude contours in the cross section of a main fractionator column below the packing entrance without an embodiment of the claimed F-Flute gas distributor.

[00024] FIG. 8 illustrates a color computational fluid dynamics simulation of gas distribution velocity magnitude contours in the cross section of a main fractionator column below the packing entrance with an embodiment of the claimed F-Flute gas distributor.

[00025] FIG. 9 illustrates a color computational fluid dynamics simulation of gas distribution vertical velocity magnitude contours in the cross section of a main fractionator below the packing entrance without an embodiment of the claimed F-Flute gas distributor.

[00026] FIG. 10 illustrates a color computational fluid dynamics simulation of gas distribution vertical velocity magnitude contours in the cross section of a main fractionator below the packing entrance with an embodiment of the claimed F-Flute gas distributor.

[00027] FIG. 11 illustrates a color computational fluid dynamics simulation of gas distribution velocity magnitude contours with an embodiment of the claimed F-Flute gas distributor at feed gas inlet nozzle level.

[00028] FIG. 12 is a cross-section view the claimed gas distributor having an F-Flute design with exemplary dimensions in millimeters and marking indicating high high liquid level (HHLL), high liquid level (HLL), and low liquid level (LLL) positions.

DETAILED DESCRIPTION OF THE INVENTION

[00029] The present claimed invention is directed to a gas distributor for use in a heat exchange and/or mass transfer column that evenly distributes gas from a feed gas stream about the interior of the column. In particular, the present invention relates to a gas distributor that conditions a high-entrance velocity superheated feed gas stream, so that the gas from the feed gas stream is evenly distributed within the inner periphery of the column.

[00030] The claimed gas distributor is particularly efficient at avoiding coke formation when the boiling point components of FCCU reactor products are cooled very close to their dew point. These products can condense where there are cold spots, or some reaction product components can polymerize to form large molecules that become non-volatile at feed gas inlet temperatures. Cold spots can be attributed to inadequate insulation, or high heat loss near fittings such as flanges, which facilitate condensation. If these deposited liquids

have sufficient residence time on the solid surfaces of the vessel, coke begins to accumulate on the inside of the transfer line and on the vessel walls. Once coke is formed, additional coke has a surface where it grows more easily.

[00031] Naphthenes in the feedstock to the FCC reactor are not efficiently cracked by the FCC catalyst, so they are carried with the hot reactor effluent gas to the MF column. FCC catalyst formulations in recent years have resulted in greater usage of high hydrogen-transfer reaction catalysts and operate at higher reactor temperature that favor the production of more olefins and in conjunction with heavier aromatic feeds, tend to produce higher boiling-point polynuclear aromatics (PNAs), which are more likely to condense at the point of entry to the MF column. Once these PNAs condense on solid surfaces inside the column, they easily form coke. High rare earth zeolite FCC catalyst tends to form aromatics from naphthenes as a result of secondary hydrogen transfer reactions. These aromatics can undergo further thermal reactions to form coke.

[00032] Coke formation has been described by the following two independent mechanisms: (i) "Asphaltic Coke" is formed as solutizing oils are thermally cracked and the remaining large asphaltene and resin molecules precipitate out to form a solid structure (coke) without much change in form; and (ii) "Thermal Coke" is produced by cross-linking of aromatic rings.

[00033] The first condensed droplets from the superheated reactor feed gas stream to the gas distributor are likely to be heavy oil rich in asphaltenes and resins. If this material reaches a rough metal surface in a low velocity area of the MF column, the long residence time there may allow the solvent oils to slowly evaporate and form coke by precipitation. Once coke deposits, it becomes an ideal site for more condensed droplets to deposit on its rough surface and cause growth of a coke site.

[00034] There are two basic principles for minimizing coke formation that are utilized in the present invention, the first is to avoid dead spots by preventing heat losses from bare metal surface, and the second is to keep solid surfaces wetted. In the instant invention, reactor effluent (i.e., superheated feed gas to the gas distributor) enters the main column and is cooled through direct contact with cold slurry pumparound. The MF column uses packing, shed (baffle), or disc

and donut trays to contact the two streams, i.e., gas from the feed gas stream and slurry liquid. The packing/trays work by creating a sheet of liquid that the hot gas must pass through. Ideally, the gas and liquid are uniformly distributed. However, in practice, this uniform gas and liquid distribution does not occur. Liquid and gas distribution is generally poor, hence the packing, shed or disc and donut trays flood well below their rated capacities.

[00035] Due to maldistribution of the liquid and gas of the prior art devices, in some instances, more than 50% of the MF column inlet nozzle is blocked with coke raising gas velocity to well over 70 m/sec, which is double the design velocity. Therefore, more gas flows up the column 180 degrees from the inlet nozzle, i.e., areas in the column directly opposite the feed nozzle, which can cause localized flooding of the packing or shed (baffle) trays in the high gas velocity region. Assuming initial liquid distribution to the top packing/tray is uniform, gas temperatures leaving the packing/trays are higher at 180 degrees from the inlet nozzle due to gas maldistribution. Columns fitted with thermocouples located in the gas space above the packing/trays, which are oriented directly above and at 180 degrees from the inlet nozzle, have temperature differences up to 50°C. Once the packing trays flood, cold slurry is entrained into the wash oil trays located directly above the slurry section packing. As a result, the pressure drop across the wash oil trays increases, further impacting unit pressure balance.

[00036] The above-mentioned gas and liquid maldistribution in the slurry section above the feed gas inlet is resolved with the presently claimed F-Flute gas distributor. The instant gas distributor provides more uniform flow entering the slurry pumparound bed, withstands the high temperature erosive environment, and resists damage and coking.

[00037] Both conventional tangential distributors (e.g., Vapor Horns, Vane Inlet Devices, and V-Baffles) and radial flow multivane distributors (e.g., Schoepentoeter) have proven not to work in FCCU main fractionators due to coking, erosion, or both. Poorly designed distributors have coked to the point that gas flow was obstructed, resulting in premature shutdowns.

[00038] The inventors note the staggered pipe plate distributor is a gas distributor that can roughly distribute the gas while remaining coke free throughout the run. The staggered pipe plate distributor comprises staggered pipe placed on an oval shaped ring placed in the column at an angle to the direction of gas upflow above the feed nozzle where the feed gas and slurry

liquid from the packed slurry section flow through the distributor counter currently. The success of the distributor in combating coking is due to the immediate and continuous washing action of the asphaltene droplets condensing on the distributor pipes by the flowing slurry liquid. However, this distributor provides limited improvement of gas distribution to the packed section above.

[00039] If the slurry pumparound section is designed properly, there will be very little entrainment and no need to have a wash section. However, when there is high entrainment, the correct solution is to fix the slurry pumparound section to reduce the entrainment. Thus, the wash oil section serves no purpose and can be eliminated.

[00040] There are two main mechanisms that contribute to wash oil section coking. The first is entrainment of slurry pumparound liquid into the wash oil section, and the second is local hot areas on the wash oil tray. In some cases, both occur at the same time, causing rapid coke formation and ultimately an unscheduled shutdown.

[00041] When slurry pumparound liquid becomes entrained with the gas from the pumparound section and cannot drain because the wash oil trays are heavily loaded, or blowing (i.e., high gas rate and low liquid rate) is occurring, coke is formed. Entrainment alone is not the problem, as the entrained liquid must be subjected to prolonged residence time and relatively high localized temperatures. Moreover, local temperatures can be very high at the same time that liquid flow rates are extremely low, thereby creating ideal conditions for coke to form.

[00042] Prior art devices, such as the Vapor Horn and the Schoepentoeter have not been successful in evenly distributing the feed gas stream to the section directly above the feed gas inlet nozzle in MF column. This is because as the feed gas stream cools inside these devices and the heaviest components, which included asphaltenes, start condensing and deposit/stick on the cool surfaces of the devices. By continuous contact with the hot feed gas, there is stripping of the lighter material from the deposit. Additionally, stripping of hydrogen atoms from the polymerized asphaltenes causes it to turn to coke. With time, the coke deposits grow to a significant size and cause interference with the flow of gas. As a result, the devices have to be removed from the MF columns.

[00043] In order to increase the efficiency of the heat exchange and mass transfer taking place between the gas of the feed gas stream and slurry liquid, it is important that the gas be uniformly distributed across the horizontal cross-section of the column, particularly at the lower gas-liquid interface where the gas enters the packing. When the feed gas stream is introduced from a feed gas inlet nozzle into the column below the packing without a gas distributor, the momentum of the gas can prevent the desired horizontal distribution of the gas prior to its entry into the packing.

[00044] Additionally, for optimum operation of the packed slurry section in main fractionator columns an even distribution of liquid films and gas flow through the packing is required. While the role of proper liquid distribution was never disputed, prior art devices have neglected the initial distribution of gas within the column. The importance of the initial gas distribution within the column has become more evident as large column diameters with short bottom sections and packing with lower pressure drop are considered. Thus, the instant F-Flute gas distribution system introduces, for example, the superheated FCC reactor gas (i.e., a superheated feed gas stream) into the column and distributes it evenly over the entire cross section of the column.

[00045] To achieve this, the velocity of the feed gas stream needs to be reduced over a short distance between the feed gas inlet nozzle and the packing and/or tray section above. At the same time, the feed gas inlet nozzle should not unduly block the column cross section or lead to excessive pressure drops. For economic reasons, a minimum distance between the nozzle and the packing/trays is desired, thus an efficient gas distributor device is highly desirable.

[00046] The presently claimed gas distributor provides a solution to the problems of the prior art devices. The gas distributor is for a heat exchange and/or mass transfer column. The F-Flute design provides even distribution of a superheated feed gas stream utilizing an open internal shell column having a generally vertical center axis. At least one feed gas inlet nozzle extends through the column shell wall and directs the superheated feed gas stream towards a generally annular vertical interior cylindrical deflecting wall that is spaced radially inwardly from the feed gas inlet nozzle, so that the feed gas travels in a circumferential direction. The gas distributor further comprises a ceiling and a bottom

extending between the internal deflecting wall and the column shell to substantially close the top and extend the bottom of the distributor in a cylindrical or cone shape bottom section to the column sump. Thus, the F-Flute gas distributor prevents direct feed gas bypassing to the packed section above.

[00047] The claimed gas distributor has an “F-Flute” design that cools the feed gas stream by contacting it with a counter-current flow of slurry liquid from the column slurry section above the gas distributor. As such, the slurry liquid is partly vaporize upon contact with the feed gas stream causing the feed gas stream to cool. The down-flowing slurry liquid “washes” and disengages the solid catalyst fines if present in the feed gas stream.

[00048] The cooled gas of the feed gas stream leaves the F-Flute gas distributor through both vent windows in the circumferential interior cylindrical deflector wall and gas openings in the ceiling of the F-Flute gas distributor. The ceiling (i.e., roof) of the F-Flute gas distributor occupies the space between the top of the substantially vertical circumferential interior cylindrical deflector wall and the interior wall of the column shell. As such, the ceiling defines the top of a feed gas flow channel and separates the feed gas flow channel from interior full cross section open area above the F-Flute gas distributor within the column. The slurry liquid from the packed section above the interior full cross section open area partly collects on top of the ceiling to a level of about 25 mm to about 50 mm depending on the type of ceiling. By various means, as more fully described herein below, the slurry liquid cascades over or “showers” down through the feed gas stream in the feed gas flow channel.

[00049] According to an embodiment of the invention, the F-Flute gas distributor ceiling comprises perforated flat plate sections, or segments made of flat metal sheet containing a plurality of about 1 inch to about 1.5 inch perforations, i.e., holes, distributed evenly over the flat plate section. The sections or segments are designed to be fitted or connected together to form a ceiling between the generally annular circumferential interior cylindrical deflector wall and the interior side of the column shell wall. The sections forming the ceiling, for example, can be welded to a circumferential rim. The perforated flat plate sections or segments allow both the cooled gas of the feed gas stream and slurry liquid to flow through perforations (holes), with a reduction in the amount of slurry liquid that collects on the top of the ceiling. Specifically, the

holes in the ceiling allow the gas and slurry liquid to alternatively pass through the same perforation and provides a quick washing effect. Any coke particles formed that otherwise would be carried with the gas are picked up by the contacting liquid and washed downward with the flowing slurry liquid. In this regard, the plurality of holes in the ceiling distribute the downwardly flowing slurry liquid in a shower type fashion and create a large surface contact area of liquid to enhance the heat/mass transfer interaction with the upwardly flowing gas of the feed gas stream. Using perforated flat plate sections reduces or minimizes the liquid hold up on the roof.

[00050] In another embodiment of the invention, the F-Flute gas distributor ceiling in addition to a plurality of holes may comprise gas chimneys that allow the cooled gas from feed gas inside the feed gas flow channel to enter the interior full cross section open area of the column above the gas distributor and below the packing tray slurry section. The chimneys in the ceiling are surrounded by the plurality of ceiling holes and the slurry liquid from the slurry packed section collects on the top of the ceiling, as the slurry liquid passes through the plurality of holes to shower the feed gas stream.

[00051] According to another embodiment of the invention, the F-Flute gas distributor ceiling can be provided with rod-plate sections or segments comprising staggered rods spaced at least about one inch apart and welded to a circumferential rim. The rod-plate sections allow both gas and slurry liquid to flow through the spacing between the staggered rods. This design forces the up-flowing gas to intimately contact the down-flowing slurry liquid, thus giving rise to froth formation on the top of the rod-plate sections, but with a minimum amount of slurry liquid collecting or holding up on top of the rods.

[00052] Yet, according to another embodiment of the invention, the F-Flute gas distributor ceiling comprises perforated corrugated plate sections or segments made of a perforated corrugated sheet metal welded to a circumferential rim. The perforations (i.e., holes) on the corrugated plate allow both gas and slurry liquid to alternatively pass through. Further, the corrugated sheet provides increased surface and open area (i.e., more holes) for both the gas and liquid to pass through the ceiling. Furthermore, the corrugated sheet minimizes the liquid

collecting or holding up on the roof.

[00053] The invention further contemplates combinations of the aforementioned ceiling designs, for example, perforated corrugated plate sections with perforated flat plate sections and rod-plate sections, in addition to the chimneys. Further, the present invention differs from prior art gas distribution devices in that the presently claimed F-Flute gas distributor is constructed with metal surfaces that are extremely smooth and/or polished, as well as providing surfaces that are fully wetted with the slurry liquid to prevent coke deposition.

[00054] The F-Flute gas distributor produces a not seen before uniform and even distribution of the gas to the slurry packed section above the distributor. The advantages of the presently claimed F-Flute gas distributor can be more fully appreciated by the following description of the Figures presented herein.

[00055] FIG. 1A depicts one embodiment of the present invention. In FIG. 1A, the F-Flute gas distributor **10** is depicted generally within a column **1** for heat exchange and/or mass transfer. The column **1** can be any type of column for heat exchange and/or mass transfer, including but not limited to, main fractionators, distillation, absorption, stripping, quench oil and/or quench water towers, decoking towers and superfractionators. The column **1** can be of any desired shape, including, but not limited to circular, oval, square, rectangular or other polygonal cross section. The column **1** of FIG. 1A is an open internal shell and having a generally vertical center axis and generally annular shape. The F-Flute distributor **10** can be designed to accommodate any shape of any heat transfer and/or mass transfer column.

[00056] In FIG. 1A a feed gas flow channel **14** is formed between the interior of the shell wall **15** of the column **1**, the interior cylindrical deflector wall **12**, and ceiling **11**. The F-Flute gas distributor **10** further comprises a bottom section **13** that can be cone shape to accommodate the contour of the column shell wall **15**. A high velocity superheated feed gas **30** is introduced into the feed gas flow channel **14** through at least one gas inlet nozzle **20** in a direction generally perpendicular to the height of the column **1**. The superheated feed gas **30** flow travels through feed gas flow channel **14** circumferentially along the generally cylindrical exterior column shell wall **15** of

column **1** due to centrifugal forces and the high rate at which the superheated feed gas **30** is introduced into the F-Flute gas distributor **10**.

[00057] The interior cylindrical deflector wall **12** and ceiling **11** of the F-Flute gas distributor **10** may be constructed of any high temperature steel material suitable for the heat and/or mass transfer processes that will not be susceptible to degradation from high velocity superheated gas **30** flow of volatile chemicals, liquids and solid particulates, as is well known to those skilled in the art.

[00058] As shown in FIG. 1A, the superheated feed gas **30** flows circumferentially around gas flow channel **14** within F-Flute gas distributor **10**. The superheated feed gas **30** from gas inlet nozzle **20** flows through gas flow channel **14** in which solids and liquids are separated as the superheated gas is cooled. The gas of superheated feed gas **30** is removed from the feed gas flow channel **14** by multiple means. The first means comprises vent windows **21** provided in the interior cylindrical deflector wall **12**. The vent windows **21** allow the cooled gas to exit the feed gas flow channel **14**. In an embodiment of the invention, the number of vent windows **21** ranges from about 10 to about 30. The vent windows **21** can be any size up to about 1 meter x 0.6 meters. The gas exiting the feed gas flow channel **14** via the vent window **21** flows into an interior open area **23** formed by the cylindrical shape of the interior cylindrical deflector wall **12** and annular construction of the F-Flute gas distributor **10**. The gas then proceeds upwardly to the interior full cross section open area **25** of the column **1** as well as the contact packing and/or trays **40** of the column **1** located above the F-Flute gas distributor **10**.

[00059] Additional means shown in FIG. 1A by which the gas from the superheated feed gas **30** is separated and directed into the interior full cross section open area **25** of the column **1** above the F-Flute gas distributor **10** are located in the ceiling **11** of the F-Flute gas distributor **10**. According to one embodiment of the invention, the ceiling **11** comprises chimneys **24** which allow the cooled gas from the superheated feed gas **30** proceeds upwardly to the interior full cross section open area **25** of column **1** and contact packing and/or trays **40** of the column **1** located above the F-Flute gas distributor **10**.

[00060] The chimneys **24** can be equipped with high hats **41** (see FIG. 1C) to regulate the rate at which gas from multiphase superheated feed gas **30** is allowed to leave gas flow channel

14 through chimneys **24**. According to an embodiment of the invention, the number of chimneys **24** ranges from about 1 to about 3 per meter of length of the feed gas flow channel **14**. The chimneys **24** have a cross sectional area ranging from about 0.1 to about 0.4 m² and the high hats **41** are constructed from about 100 mm to about 300 mm above the chimneys **24** and have a cross sectional area ranging from about 0.1 to about 0.4 m² or larger.

[00061] FIG. 1A displays the cone shape bottom section **13** of the F-Flute gas distributor **10** which comprises a bottom section opening **16** and at least one overflow opening **27** that feeds into the column sump **28** of the column **1** located directly below the F-Flute gas distributor **10**. The overflow openings **27** provide for drainage of liquid that has been separated from the gas in and above the interior open area **23** into the column sump **28**. According to an embodiment of the invention, the number of overflow openings **27** ranges from about 4 to about 6. The overflow openings **27** are sized to accommodate all liquid showering or raining into the interior open area **23** of the F-Flute gas distributor **10** and acting as an overflow spillway in case the drain pipe **18** in fluid communication with bottom section opening **16** becomes clogged. FIG. 1A further displays marking indicating high high liquid level (HLL), normal liquid level (NLL), and low liquid level (LLL) positions.

[00062] FIG. 1B is an isometric 3D view of the F-Flute gas distributor **10** outside of the column **1**, including the ceiling **11**, which comprises ceiling sections **29A**, and **29C** (**29B**, **29D** not shown in FIG 1B), the interior cylindrical deflector wall **12** comprised of wall segments **12A** connected together by conventional techniques known to those of ordinary skill in the art in an annular fashion to provide interior cylindrical deflector wall **12**. FIG. 1B further displays the cone shape bottom section **13** of the F-Flute gas distributor **10**. In an embodiment of the present invention, the interior cylindrical deflector wall **12** comprises wall segments **12A** that are sized to provide widths that can pass through a given manway. Vent windows **21** are located in several wall segments **12A** around the interior cylindrical deflector wall **12**. Vent windows **21** can be cut into the wall segments **12A** or into the interior cylindrical deflector wall **12**. When segments **12A** are used to provide the interior cylindrical deflector wall **12** they continue in an annular fashion including vent windows **21** until they form the interior open area **23** of the F-Flute gas distributor **10**. The segments **12A** that make up the feed gas flow channel **14** are generally uniform in size, i.e., height and width.

[00063] FIG. 1B shows the ceiling **11** comprising ceiling sections **29A**, **29C** that can comprise one or more of solid sheet metal (not shown), a metal perforated flat plate section **29C**, and perforated flat plate section with chimneys and high hats **29A** (see also FIG. 1C) that allow the gas to flow out of the F-Flute gas distributor **10** and into the interior full cross section open area **25** of the column **1**.

[00064] Each perforated flat plate section with chimneys and high hats **29A** as presented in FIG. 1C is furnished with at least two chimneys **24** and a plurality of perforations, i.e., holes **42**. The holes **42** are drilled between the chimneys and sized to hold-up just enough liquid to create a gas seal.

[00065] In FIG. 1A and FIG. 1B, the cone shape bottom section **13** of the F-Flute gas distributor **10** is conically shaped to accommodate the lower portion of column **1** and feeds into column sump **28**. Further, the cone shape bottom section **13** can comprise bottom section segments **13A** that are connected together and extend interior cylindrical deflector wall **12** in a fashion that forms a conical shape to the lower portion of the feed gas flow channel **14** while further accommodating the shape of the column **1**. Although bottom section **13** of the F-Flute gas distributor **10** is cone shaped, as depicted as in FIGs. 1A and 1B, it is contemplated that any shape required to accommodate the lower portion of the heat exchange and/or mass transfer column and extend the interior cylindrical deflector wall **12** to feed liquids and solid particles to the column sump can be used. The segments of cone shape bottom section **13** are sized to provide widths that can pass through a manway.

[00066] The cone shaped bottom section **13** serves two purposes: to prevent the gas from feed gas inlet nozzle **20** from bypassing the F-Flute gas distributor **10** openings, i.e., the vent windows **21** and chimneys **24**; and to facilitate the draining of the drops to the interior open area **23** of the F-Flute gas distributor **10** to the column sump **28** without possibility of liquid entrainment. In other words, the gas is separated from the drops falling outside the F-Flute gas distributor. The cone shape follow the contour of the tower swage section, allowing quick draining of liquid and help prevent re-entrainment of liquid into the vapor stream.

[00067] According to an embodiment of the invention, the superheated feed gas **30** is cooled as it circulates inside the F-Flute gas distributor **10** feed gas flow channel **14** by the counter-current flow of

“drops” of the slurry liquid from the column slurry section liquid falling from holes **42** in the ceiling sections. This effect provides greater heat transfer inside the F-Flute gas distributor **10** when compared to a column that does not contain a gas distributor because: (i) the velocity of the superheated feed gas **30** inside the F-Flute gas distributor **10** is higher than the velocity of the gas in the column (this effect of increased velocity of the superheated feed gas **30** past the slurry liquid drops improves heat transfer rates); (ii) this higher velocity and turbulence of the superheated feed gas **30** tends to aerodynamically breakup the slurry liquid drops inside the F-Flute gas distributor **10**, increasing their interfacial surface area for heat and mass transfer; (iii) the F-Flute gas distributor **10** provides greater wetted surface area for greater convective heat transfer; and (iv) the F-Flute gas distributor **10** creates an even distribution of gas to the packing, and prevents the segregation of liquid drops and gas caused by the nozzle jetting into an empty tower. The beneficial result of all these advantages is that the F-Flute gas distributor increases the heat transfer rate from gas to the slurry liquid drops and this allows a smaller length of tower/column for a given amount of heat and mass transfer.

[00068] Alternatively, the present invention F-Flute gas distributor's **10** ceiling **11** can be made up of rod-plate sections **29B** as presented in FIG. 2A. The rod-plate section **29B** as presented in FIG. 2A comprises staggered rods **43** that are spaced at a minimum of about 1 to about 1-1/2 inches apart and can be welded to a circumferential rim. The staggered rods **43** can be positioned in one or various combinations of patterns, e.g., herringbone, diagonal, etc., as presented in FIG. 2B. The rod-plate sections **29B** allow both the gas and the slurry liquid to flow through the spacing between the rods. This forces the up-flowing gas from feed gas flow channel **14** to intimately contact the down-flowing slurry liquid, thus giving rise to froth formation on top of the rod-plate sections **29B**. There is a small amount of slurry liquid hold up on the staggered rods **43**. However, the ceiling design of FIG. 2B reduces the slurry liquid hold up on the ceiling section compared to that of the perforated flat plate section with chimneys and high hats presented in FIG. 1B.

[00069] FIG. 3A presents another alternative to the F-Flute gas distributor **10**, wherein the ceiling section comprises perforated flat plate sections **29C**. The perforated flat plate sections **29C** are perforated with holes **42**. The perforated flat plate sections **29C** can be made of sheet metal and welded to a circumferential rim. The holes **42** in the perforated flat plate section **29C**

allow both gas and slurry liquid to alternatively pass through. The countercurrent flow of gas and liquid alternatively through the same perforations provide quick washing effect of any coke particles formed and carried with the gas. The solid particles are picked up by the contacting liquid and washed downward with the flowing slurry liquid. The perforated flat sheet sections **29C**, as presented in FIG. 3B, are the simplest to construct and provide minimized liquid hold up on the top of ceiling **11**.

[00070] FIG. 3B is an isometric 3D view of the F-Flute gas distributor **10** outside of the column **1**, including the ceiling **11**, which comprises ceiling section **29C** (**29A**, **29B**, **29D** not shown in FIG 3B), the interior cylindrical deflector wall **12** comprised of wall segments **12A** connected together by conventional techniques known to those of ordinary skill in the art in an annular fashion to provide interior cylindrical deflector wall **12**. FIG. 3B further displays the cone shape bottom section **13** of the F-Flute gas distributor **10**. the interior cylindrical deflector wall **12** comprises wall segments **12A**, vent windows **21** are located in several wall segments **12A** around the interior cylindrical deflector wall **12**. The segments **12A** that make up the feed gas flow channel **14** are generally uniform in size, i.e., height and width and allow gas to enter the interior open area **23**.

[00071] FIG. 4A presents yet another alternative type of F-Flute gas distributor **10** ceiling **11** containing perforated corrugated plate sections **29D**. In FIG. 4A, the perforated corrugated plate sections **29D** are made of sheet metal and can be welded to a circumferential rim. The perforations (i.e., holes **42**) on the corrugated plate allow both gas and slurry liquid to alternatively pass through. The perforated corrugated plate sections **29D** corrugated sheet provides increased effective area for both the gas and liquid to pass through the roof. The countercurrent flow of gas and liquid alternatively through the same corrugation holes provide quick washing effect of any coke particles formed and carried with the gas. Such particles are picked up by the contacting liquid and washed downward with the flowing slurry liquid to the column sump **28**. Also, the perforated corrugated plate sections **29D** minimizes the liquid hold up on the roof. This type of F-Flute gas distributor **10** as presented in FIG. 4B, with perforated corrugated plate sections **29D** represent a preferred option for use in a main fractionator column, as it offer the highest resistance to fouling with coke.

[00072] The presently claimed F-Flute gas distributor **10** invention can use of any combination of the afore described ceiling sections.

[00073] FIG. 5 is a graphic representation of the superheated feed gas and slurry liquid temperature (°C) and traffic (i.e., gas and liquid flow rate in kg/hr). The temperatures and flow rates are measured from the F-Flute gas distributor's inlet area, i.e., the superheated feed gas at gas inlet nozzle of FIG. 1A to the packing inlet. The simulated traffic and temperature of both slurry liquid (which enters the column **1** through slurry liquid distributor **44** of FIG. 1A) and superheated gas stream into and out of the F-Flute gas distributor. The graphic representation indicates that the superheated feed gas enters the claimed F-Flute gas distributor at a temperature of approximately 560 C° and is immediately quenched to approximately 420 C° inside the F-flute gas distributor's feed gas flow channel by evaporating the slurry liquid. Thus, the mass flow of gas increases from approximately from about 500,000 kg/hr to a maximum of approximately 1,600,000 kg/hr, and similarly the liquid rate increases and drops to approximately 1,100,000 kg/hr from 1,550,000 kg/hr to 450,000 kg/hr. The gas from the superheated gas feed leaves the F-Flute gas distributor (flute outlet) at a rate of approximately 1,200,000 kg/hr and a temperature of approximately 410°C.

[00074] FIG. 6 is a graphic representation of the cost ratio for revamping three different size main fractionator towers with the presently claimed F-Flute gas distribution of FIG. 1A. Conventional revamping of existing main fractionator towers require replacing the tower feed nozzle(s) and swaging a portion of the length of refractory line transfer line leading to the feed nozzle, of a length equivalent to 5-7 time the feed nozzle diameter, in proportional cross sectional area to the ratio of the revamp/original design capacity. This elaborate work can be avoided by installing the claimed F-flute gas distributor, since it provides an even distribution of the quenched superheated feed gas under the packing above the feed nozzle. The cost advantage as presented in FIG. 6 are significant using the claimed F-Flute gas distributor compared with replacing the feed nozzle and swaging the transfer line duct work, i.e., in a 37 thousand barrels per day ("KBPD") unit there is approximately 100% cost savings, in a 90 KBPD unit there is more than a 400% cost savings, and in a twin duct 125 KBPD unit there is an approximate 400% cost savings.

[00075] To show the improved gas distribution of the claimed F-Flute gas distributor of Fig. 1A,

computational fluid dynamics (CFD) simulations were prepared, the results of which are presented FIGs. 7 - 11. The computational fluid dynamics simulations of FIGs. 7 - 11 illustrate three dimensional gas distribution velocity magnitude contours in the cross section of a main fractionator column. The simulations presented in FIGs. 7 - 10 illustrate gas distribution in the cross section of a main fractionator column 5 cm below the packing entrance with and without an F-Flute gas distributor, respectively. The feed gas inlet nozzle is positioned on the left side of each Figure, i.e., FIGs. 7-11. The computational fluid dynamics simulations were based on the claimed F-Flute gas distributor having the dimensions in millimeters (mm), as presented in FIG. 12. However, gas distribution can be improved for any size vessel when the presently claimed F-Flute design gas distributor is proportioned to accommodate the vessel.

[00076] FIG. 7 and FIG. 8 present CFD simulation models of gas distribution velocity magnitude contours of gas distribution (i.e., gas distribution patterns) in the cross section of a main fractionator column 5 cm below the packing entrance with and without the claimed F-Flute gas distributor, respectively. The comparison can be measured using peak to average velocity (PAV) levels. For FIGs. 7 and 8 the PAV levels range in numerical value from 0.00 to 8.38. The empty column, i.e., FIG. 7 absent the F-Flute gas distributor, has a PAV magnitude of 8.38 times the average velocity level. FIG. 7 displays prominent velocity magnitude contours illustrated by large oval contours with high PAV levels leaving the feed gas inlet nozzle and directed to the opposite sides of the fractionator column. The large oval contours are separated by a narrow velocity magnitude contour having a low PAV level. The pattern of the velocity magnitude contours in FIG. 7 indicate an extremely uneven velocity distribution of gas within the cross section of the column. However, the simulation of the column with the claimed F-Flute gas distributor, i.e., FIG. 8, has a PAV magnitude of 4.45 that is 47% lower than the empty column. The substantially even velocity magnitude contours within the cross section of the column presented in FIG. 8 are illustrated by the uniformity of the contours displayed and the absence of high PAV levels.

[00077] FIGs. 9 and 10 are CFD simulation models of vertical gas distribution velocity magnitude contours (i.e., gas distribution patterns) at 5 cm below the packing of the column. FIG. 9 indicates the vertical gas distribution velocity magnitude contours for the empty column, i.e., absent the claimed F-Flute gas distributor, and FIG. 10 presents the vertical gas distribution velocity magnitude contours for the column with the claimed F-Flute gas distributor installed. The PAV levels range in numerical value from - 0.50 to 2.81. The simulation of the empty column in FIG. 9 measures a PAV vertical component at 2.8 times the average velocity level illustrated by significant oval velocity

magnitude contours having high PAV levels leaving the feed gas inlet nozzle and directed to the opposite sides of the fractionator column. These vertical velocity magnitude contours indicate an extremely uneven velocity distribution of gas below the packing of the column. The column in FIG. 10 with the F-Flute gas distributor, however, measures a PAV vertical component of 2.1 that is 25% lower than the empty column. The simulation models clearly indicate that the claimed F-Flute gas distributor improves the velocity uniformity, and thus improves gas distribution to the packing area when installed.

[00078] FIG. 11 is a CFD simulation model illustrating superheated feed gas velocity magnitude contours (i.e., gas distribution patterns) inside an F-Flute gas distributor of the present claimed invention at the feed gas inlet nozzle level. This simulation clearly indicates uniform velocity magnitude contours over the majority of the feed gas flow channel and interior open area of the claimed F-Flute gas distributor.

[00079] Additionally, the claimed F-Flute gas distributor will enhance heat and mass transfer by reducing the Sauter mean diameter (SMD) of the droplet distribution. Estimates based on aerodynamic breakup, indicate that the SMD of droplets inside the F-Flute gas distributor will be 33% smaller than in a column without the F-Flute gas distributor. This increases the interfacial surface area between liquid and gas to increase heat and mass transfer.

[00080] The following Table 1 presents the estimated difference in SMD and heat transfer with and without the F-Flute gas distributor of FIG. 1A.

[00081] TABLE 1:

Design	SMD- mm	Heat Transfer – Watt/°K
Empty Colum	4.0	4.2 E 05
F-Flute gas distributor 10	2.7	5.5 E 05

[00082] The plurality of vent windows in the F-Flute gas distributor are positioned throughout the interior cylindrical deflector and the wall and chimneys positioned throughout the ceiling, allow for the cooled separated superheated feed gas to exit the distributor into the column’s interior full cross section

open area with greatly slowed and uniform velocity for distribution to packing or trays located within the column and above the F-Flute gas distributor.

[00083] The walls of the F-Flute gas distributor, i.e., interior cylindrical deflector wall, cone shape bottom section that extends the interior cylindrical deflector wall and the interior side of column shell wall, which comprises the exterior wall of the F-Flute gas distributor, are entirely wetted with slurry liquid. The interior cylindrical deflector wall, bottom section, and interior side of column shell wall are completely wetted because the ceiling is connected to the interior cylindrical deflector wall and the interior side of column shell wall through a connection device, such as, a dowel, circular rim, welded rod or bracket, and the like, to include a plurality of openings so that the slurry liquid can fall vertically down the interior cylindrical deflector wall, bottom section, and interior side of column shell wall and keep them wetted.

[00084] Any condensation of high boiling point components of the super-heater feed gas components inside the F-Flute gas distributor will occur in the liquid slurry phase and will immediately mix and washed down with the flowing slurry liquid to the column sump of the MF column. This will prevent the condensed droplets of the superheated feed gas containing asphaltenes from sticking to the solid wall surfaces and being exposed for lengthy periods to hot superheated feed gas which is the main cause of coke particles formation and their growth that caused failure of the prior art gas distribution devices.

[00085] Additionally the expansion of the superheated feed gas from the feed gas inlet nozzle together with the showering of the slurry liquid from the ceiling sections inside the F-Flute gas distributor provides a vehicle for the solid catalyst fines to separate out of the superheated feed gas and be carried with the large flow of slurry liquid down to the column sump without causing erosion problems to the column walls and internals. If the solid catalyst fines and coke particle are not efficiently separated from the superheated feed gas at point of entry to the column and pass with the superheated feed gas to the slurry packed section and deposit on its packing, the column's efficiency to cool the feed gas is reduced. Moreover, the column requires more frequent cleaning for the removal of the solid catalyst fines and coke particle.

[00086] Further, the presently claimed F-Flute gas distributor has been shown to decrease significantly the maximum local gas velocity below the packing in the portion of the column

situated above the F-Flute gas distributor, i.e., cooled superheated feed gas in the interior full cross section open area. This reduction in local gas velocity results in a more uniform distribution of gas pressure and ultimately a more efficient heat transfer in the slurry section as well as better fractionation in the upper column sections. An even distribution of the gas on the packing and trays is critical for proper heat and mass transfer. Even distribution can be accomplished for a higher degree of heat exchange and fractionation through the use of the F-Flute gas distributor of the present invention, which allows the conventionally designed capacity profile of a given mass and/heat transfer column/MF column to be exceeded well beyond its traditionally accepted limitations. This results in higher capacity within the same column relative to similar devices that do not employ the gas distribution device of the present invention. The F-Flute gas distributor of the present invention would significantly decrease the maximum local velocity below a packing or tray in a column and therefore improve the velocity profile below the packing/tray.

[00087] The invention further provides lower temperature of the gas flow to the packed slurry section as well as more even distribution, these two factors result in reduction in the required column diameter. The more even distribution of bottom gas to the tower sections above improve the column internals efficiency for heat and mass transfer and leads to a reduction in the overall column height.

[00088] The novel features of the present invention have been shown to produce this uniform distribution of gas pressure at a level above any known prior art gas distributor. The presently claimed F-Flute gas distributor provides a low column skin temperature by cooling the feed gas first with the showering slurry liquid at entry to the column inside the F-Flute gas distributor.

[00089] The claimed gas distributor reduces or eliminates “jetting” of the superheated feed gas, whereby the superheated feed gas hits the column wall creating dry spots and causes the column wall to reach temperatures above the design temperature of the column shell. In this regard, the claimed F-Flute gas distributor also avoids column shell (i.e., wall) erosion by eliminating the jetting effect of the superheated feed gas containing the erosive catalyst fines that continuously and at high velocities impinge the column wall and cause local erosion and/or thinning

of the column shell in area directly opposite to the feed nozzle. The use of the claimed F-Flute gas distributor will remove the catalyst fines by the showering slurry liquid inside the F-Flute gas distributor and there will be no direct contact of the superheated feed gas with the column shell wall.

[00090] Although the present invention has been described in considerable detail with regard to certain versions thereof, other versions are possible, and alterations, permutations, and equivalents of the version shown will become apparent to those skilled in the art upon a reading of the specification and study of the drawings. Also, the various features of the versions herein can be combined in various ways to provide additional versions of the present invention. Furthermore, certain terminology has been used for the purposes of descriptive clarity, and not to limit the present invention. Therefore, any appended claims should not be limited to the description of the preferred versions contained herein and should include all such alterations, permutations, and equivalents as fall within the true spirit and scope of the present invention.

We claim:

1. A gas distributor for a heat exchange and/or mass transfer column, said gas distributor located within said column and comprising at least one feed gas inlet nozzle extending through a shell wall of the column for directing a feed gas to a substantially vertical interior cylindrical deflector wall comprising at least one opening to an annular interior open area within the gas distributor, a bottom section that extends the interior cylindrical deflector wall and conforms to the contour of the shell wall, said bottom section comprising a bottom section opening to a column sump within the column, and a generally horizontal ceiling above the feed gas inlet nozzle between the interior cylindrical deflector wall and the shell wall to define a generally circumferential gas flow channel formed between the shell wall and the interior cylindrical deflector wall, said ceiling comprising at least one opening.
2. The gas distributor of Claim 1, wherein the heat exchange and/or mass transfer column is a main fractionator column and the feed gas is superheated.
3. The gas distributor of Claim 1, wherein the bottom section is cone shape and conforms to the contour of the shell wall of the column.
4. The gas distributor of Claim 1, wherein the column further comprises packing and/or trays above the gas distributor.
5. The gas distributor of Claim 1, wherein interior cylindrical deflector wall comprises wall segments.
6. The gas distributor of Claim 5, wherein at least one of the wall segments comprises an opening.
7. The gas distributor of Claim 1, wherein the ceiling comprises at least one ceiling section.
8. The gas distributor of Claim 7, wherein at least one ceiling section is a flat plate with at least one perforation and/or chimney .
9. The gas distributor of Claim 8, wherein at least one chimney has a high hat.

10. The gas distributor of Claim 7, wherein the ceiling section comprises rods spaced at least about 1 inch apart.
11. The gas distributor of Claim 7, wherein the ceiling section is corrugated with at least one perforation and/or chimney.
12. The gas distributor of Claim 1, wherein there is a plurality of openings between ceiling and the interior cylindrical deflector wall and the ceiling and the shell wall.
13. The gas distributor of Claim 7, wherein the ceiling section is at least one selected from the group consisting of a flat plate with at least one perforation and/or chimney, a section comprising rods spaced at least about 1 inch apart, and a corrugated ceiling section with at least one perforation and/or chimney.
14. The gas distributor of Claim 6, wherein the opening is a vent window.
15. The gas distributor of Claim 1, wherein the bottom section further comprises at least one overflow opening.
16. The gas distributor of Claim 5, wherein wall segments are sized to fit through a manway.
17. The gas distributor of Claim 7, wherein the ceiling sections are sized to fit through a manway.
18. The gas distributor of Claim 1, wherein the bottom section comprises bottom section segments.
19. The gas distributor of Claim 1, wherein the superheated feed gas is distributed to an area above the gas distributor in a substantially even manner.
20. 20. The gas distributor of Claim 1, further comprising a drain pipe in fluid connection with the bottom section opening.
21. A method of improving feed gas distribution and reducing coke formation in a heat exchange and/or mass transfer column, comprising the step of delivering a high velocity superheated feed gas to the gas distributor of Claim 1.

22. A method for distributing feed gas in a heat exchange and/or mass transfer column, said method comprising the steps of:

delivering a superheated feed gas through a feed gas inlet nozzle that extends through a shell wall of the column into a generally circumferential gas flow channel formed between the shell wall, an interior cylindrical deflector wall having a bottom section and at least one opening to an annular interior open area within the column, and a ceiling above the inlet nozzle between the shell wall and the interior cylindrical deflector wall, said ceiling having a plurality of openings;

cooling the superheated feed gas by contacting the gas with a counter current flow of liquid as the liquid passes through the plurality of openings in the ceiling and into the circumferential gas flow channel;

wetting the interior cylindrical deflector wall and an interior side of the shell wall that forms the circumferential gas flow channel with the counter current flow of liquid after the liquid has passed through the plurality of ceiling openings; and

venting the superheated feed gas to an area above the ceiling and the annular interior area within the column through the at least one opening of the interior cylindrical deflector wall and the plurality of openings in the ceiling to provide a substantially uniform distribution of the superheated feed gas within the column.

23. The method of Claim 22, wherein the feed gas inlet nozzle enters the column through the shell wall and is substantially perpendicular to the longitudinal axis of the column.

24. The method of Claim 22, wherein the feed gas flow rate increase from about 500,000 Kg/h upon entering the gas flow channel to about 1,200,000 Kg/h upon leaving the plurality of openings in the ceiling and the at least one opening of the interior cylindrical deflector wall.

25. The method of Claim 22, wherein the feed gas temperature decreases from about 560° C. upon entering the gas flow channel to about 420° C. upon leaving the plurality of openings in the ceiling and the at least one opening of the interior cylindrical deflector wall.

26. The method of Claim 22, wherein there is a plurality of opening between ceiling and the interior cylindrical deflector wall and the ceiling and the shell wall.

27. The method of Claim 22, wherein the bottom section extends the interior cylindrical deflector wall and conforms to the contour of the shell wall of the column.
28. The method of Claim 22, wherein the bottom section is cone shape.

FIG. 1B

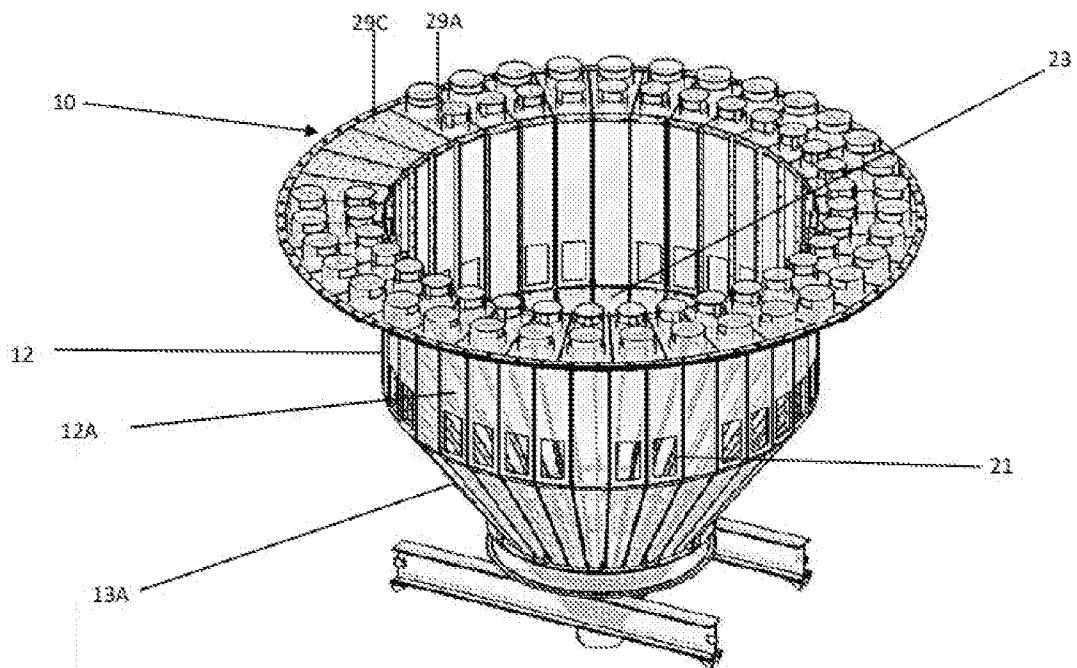
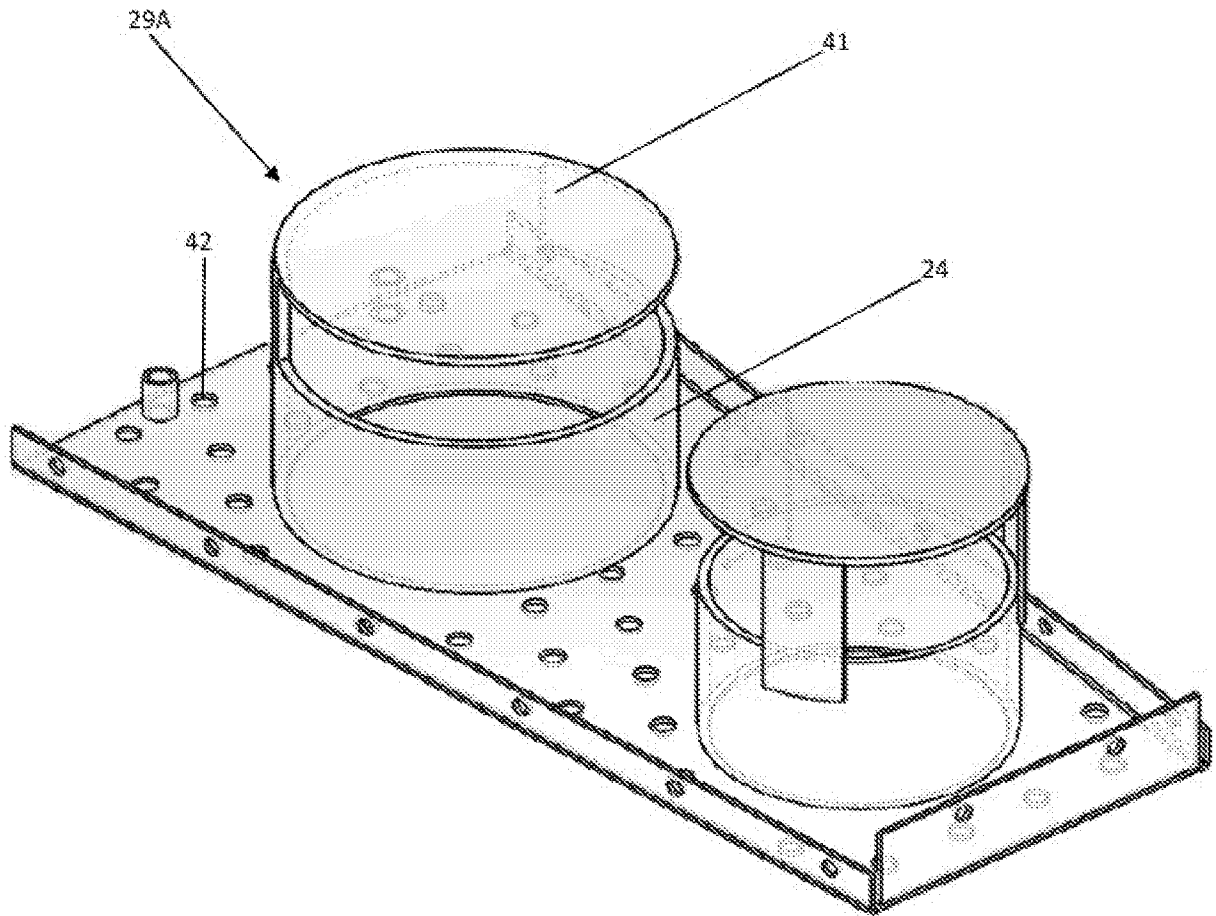

FIG. 1C



4/17

FIG. 2A

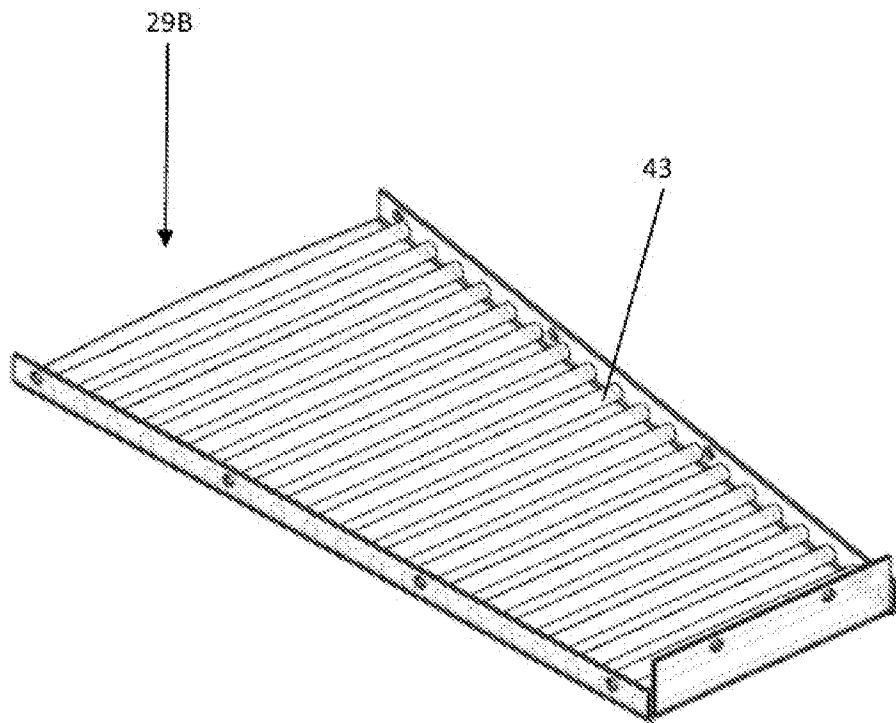

FIG. 2B

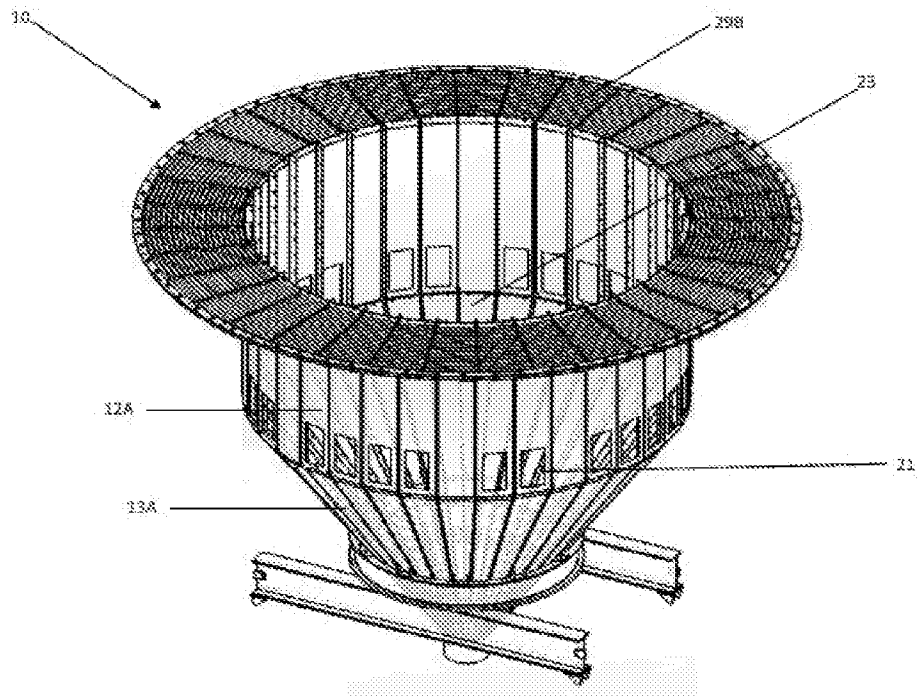
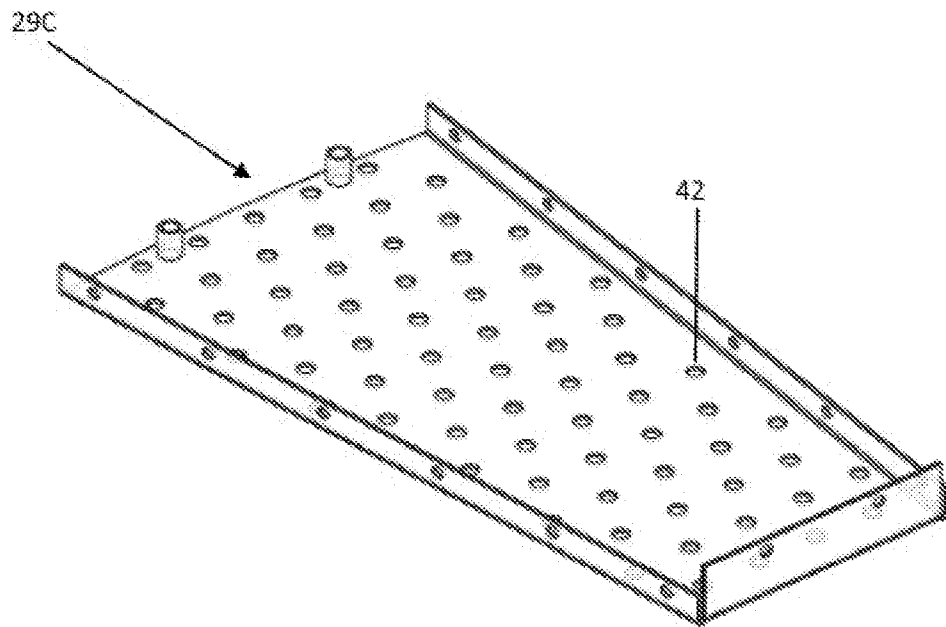
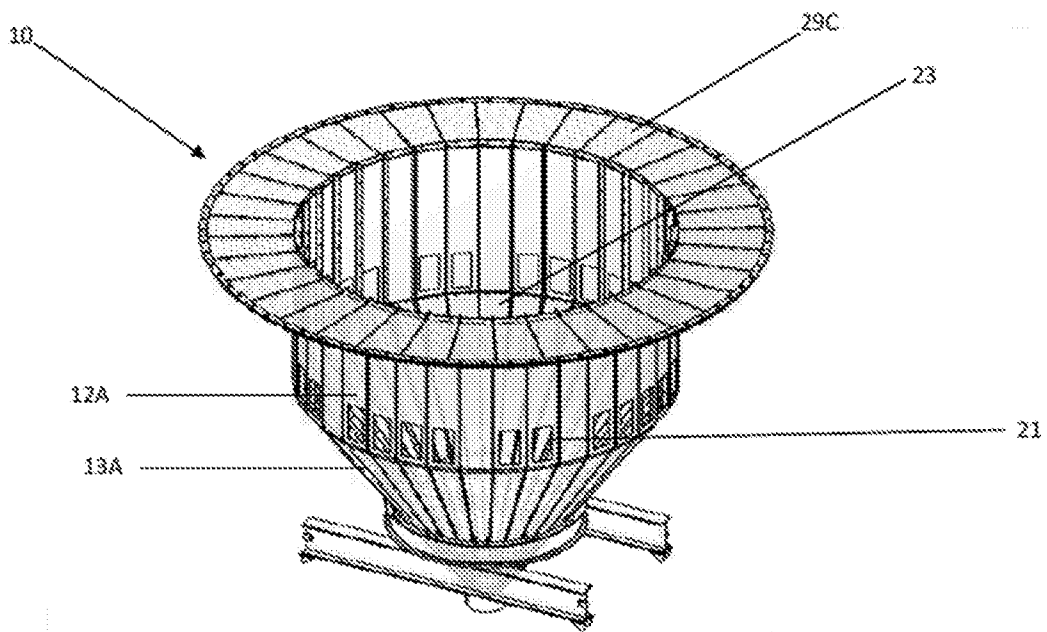

FIG. 3A



7/17

FIG. 3B



8/17

FIG. 4A

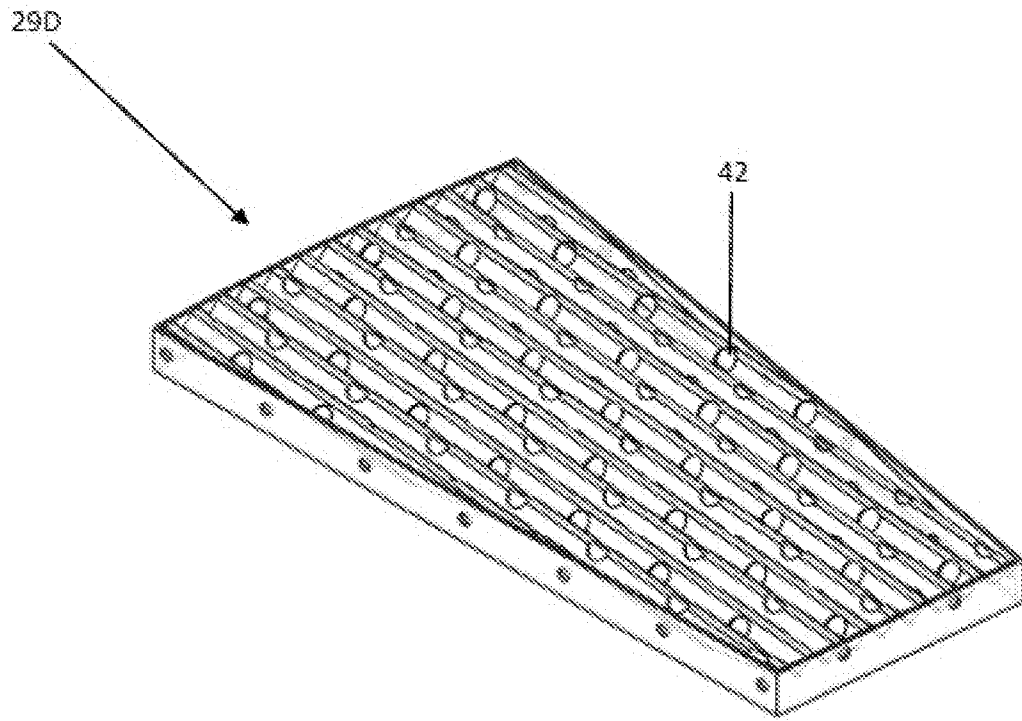

9/17

FIG. 4B

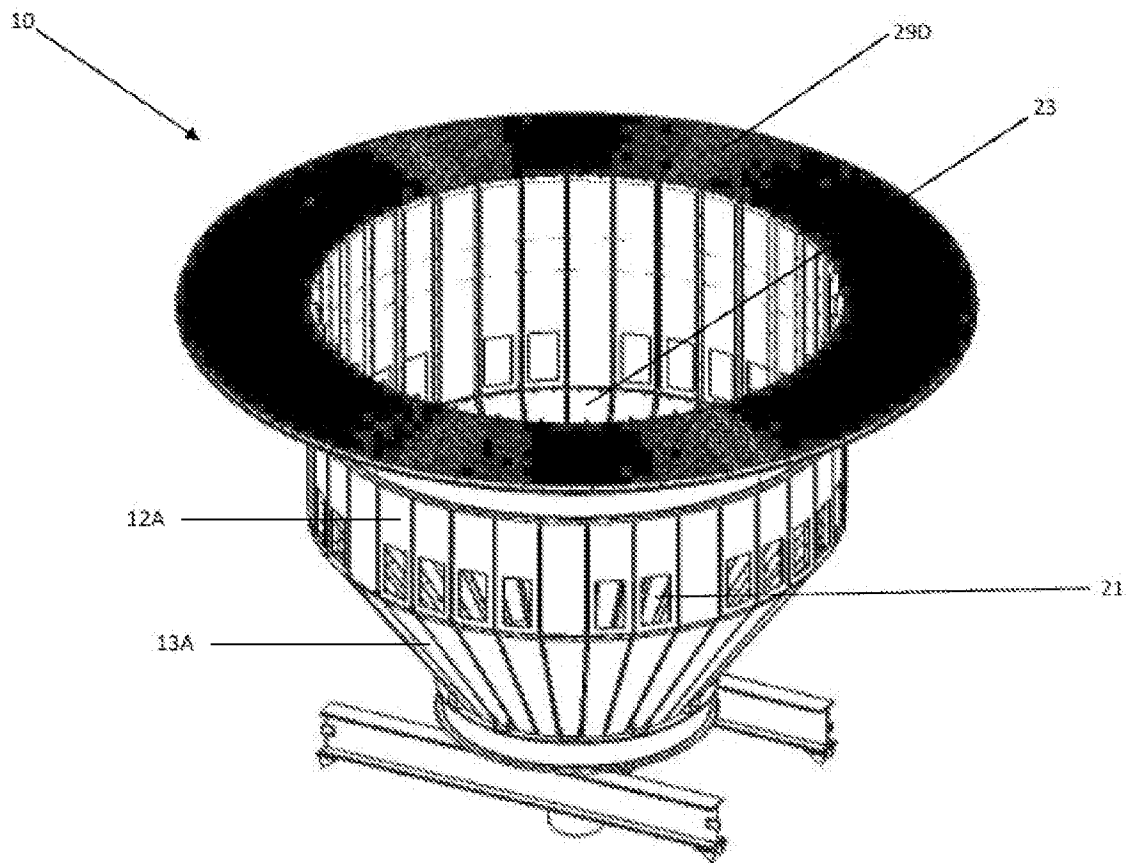

11/17

FIG. 6

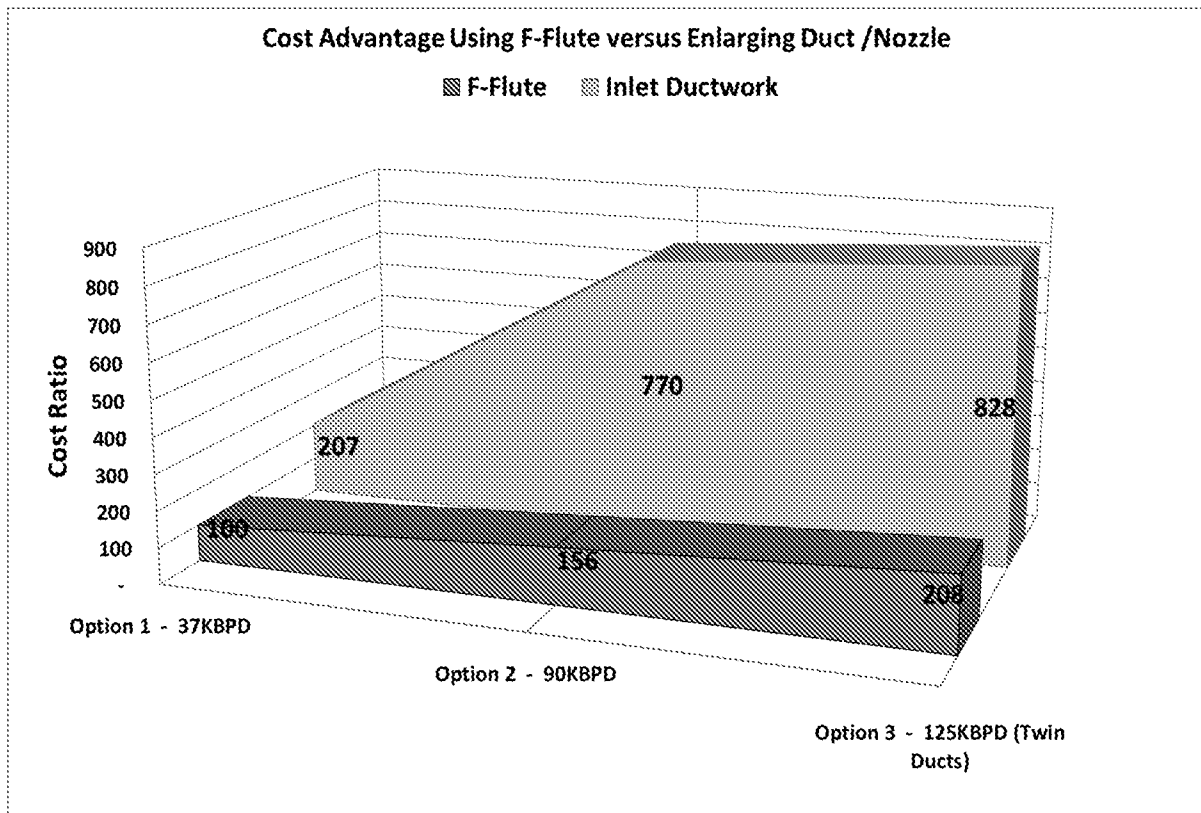

12/17

FIG. 7

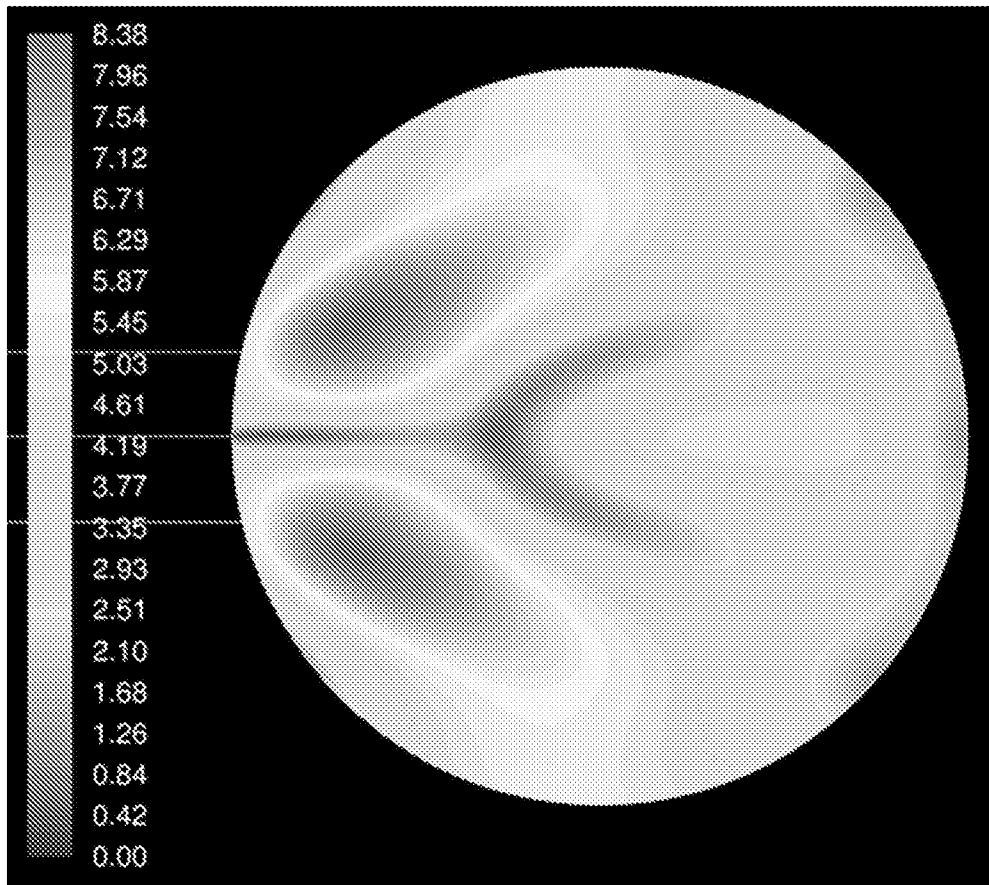
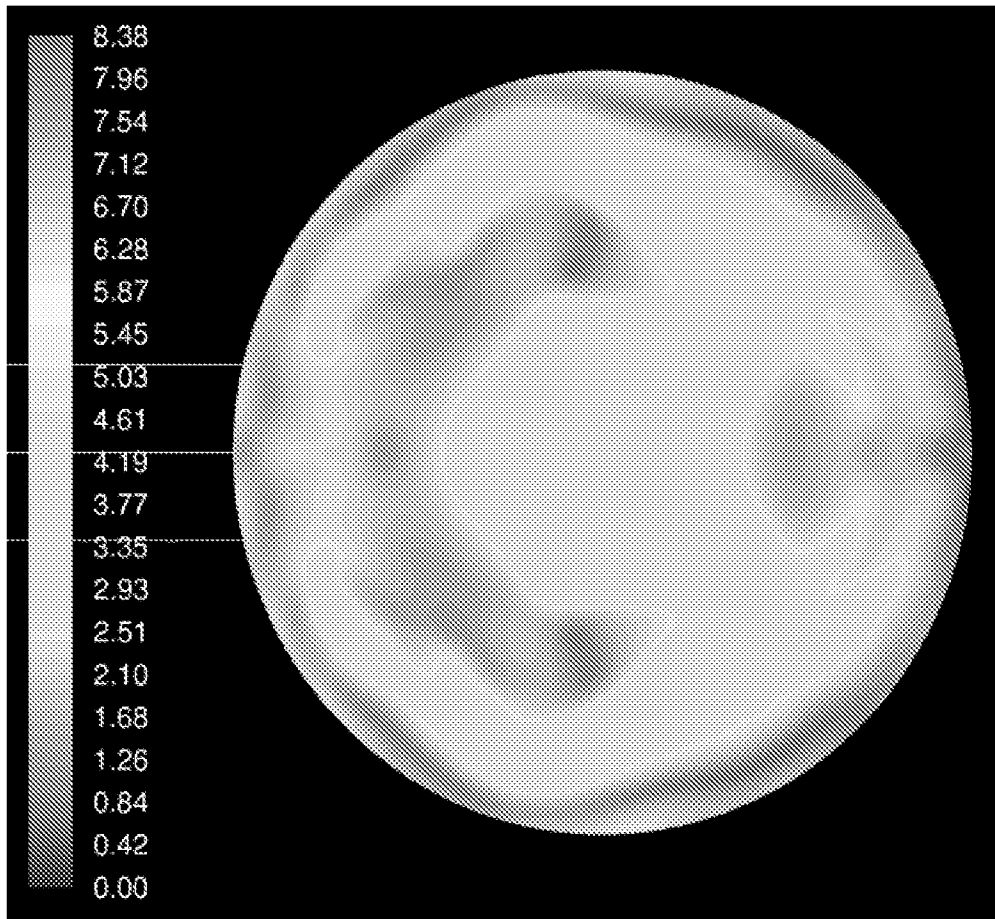
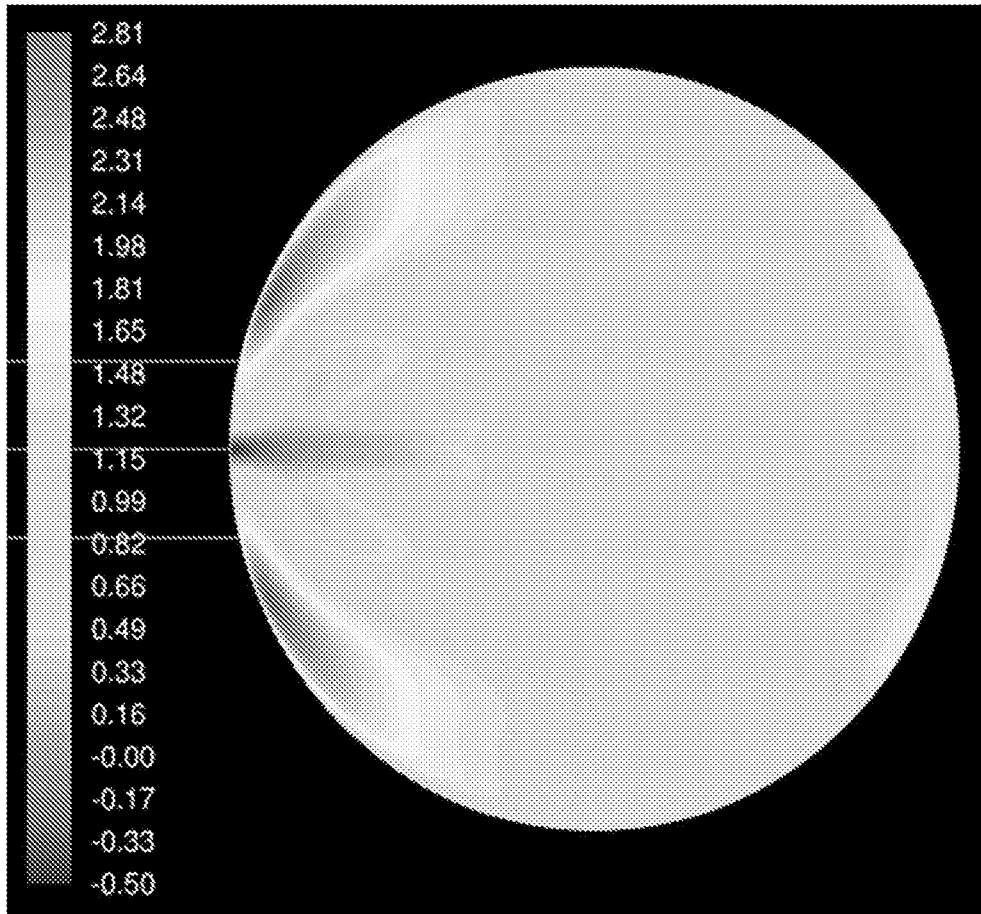

FIG. 8



14/17

FIG. 9



15/17

FIG. 10

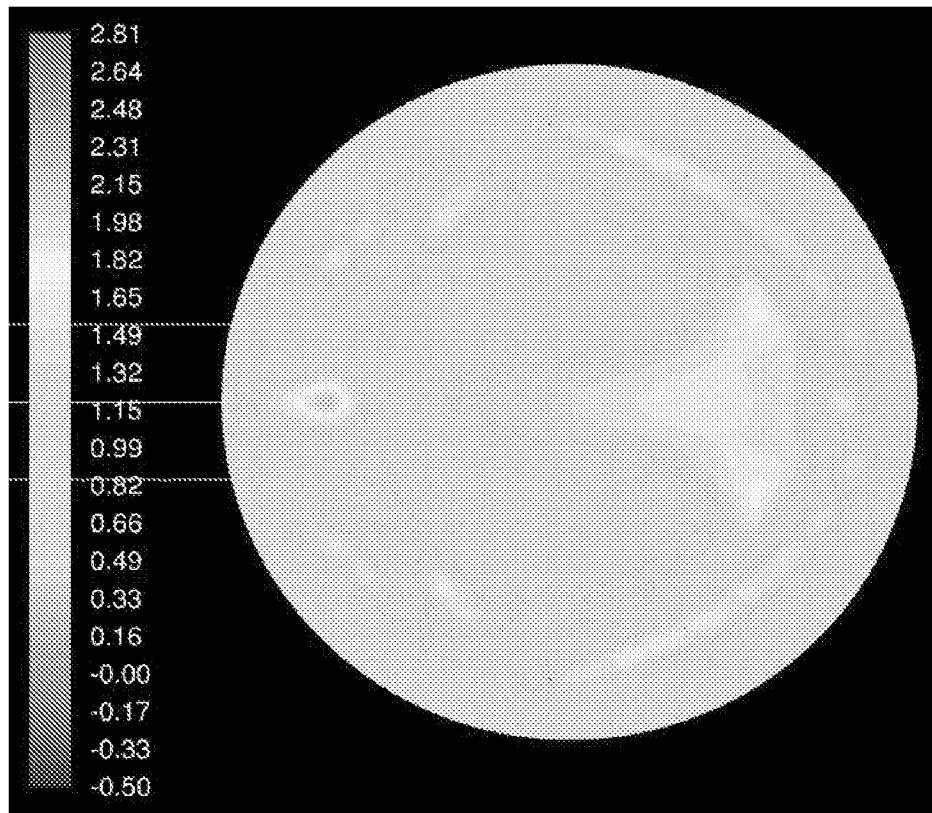

16/17

FIG. 11

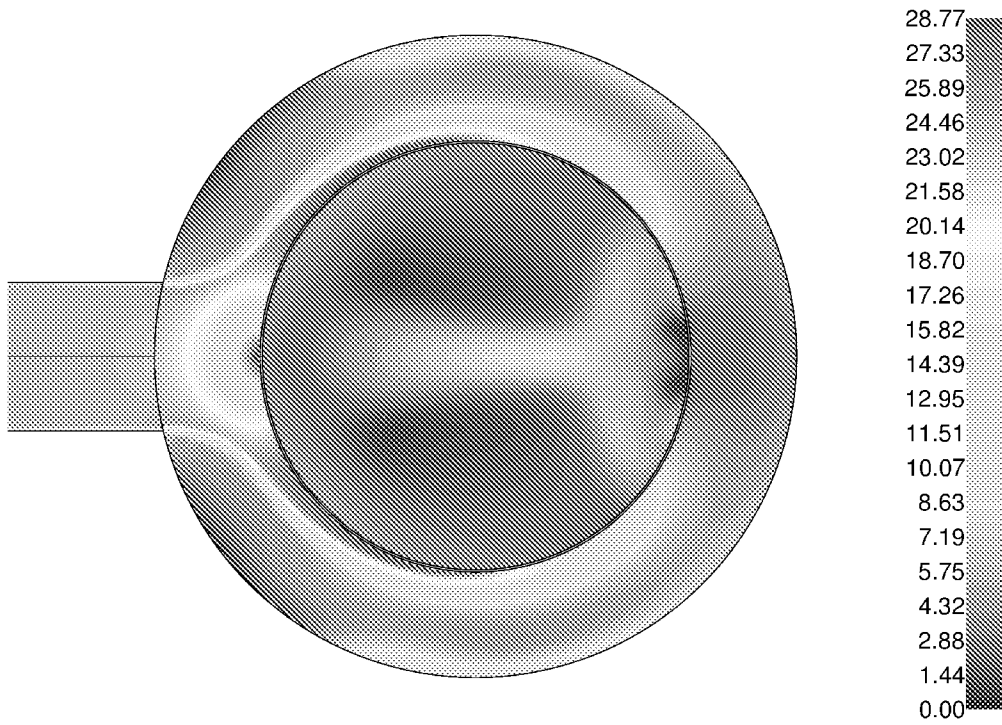

17/17

FIG. 12

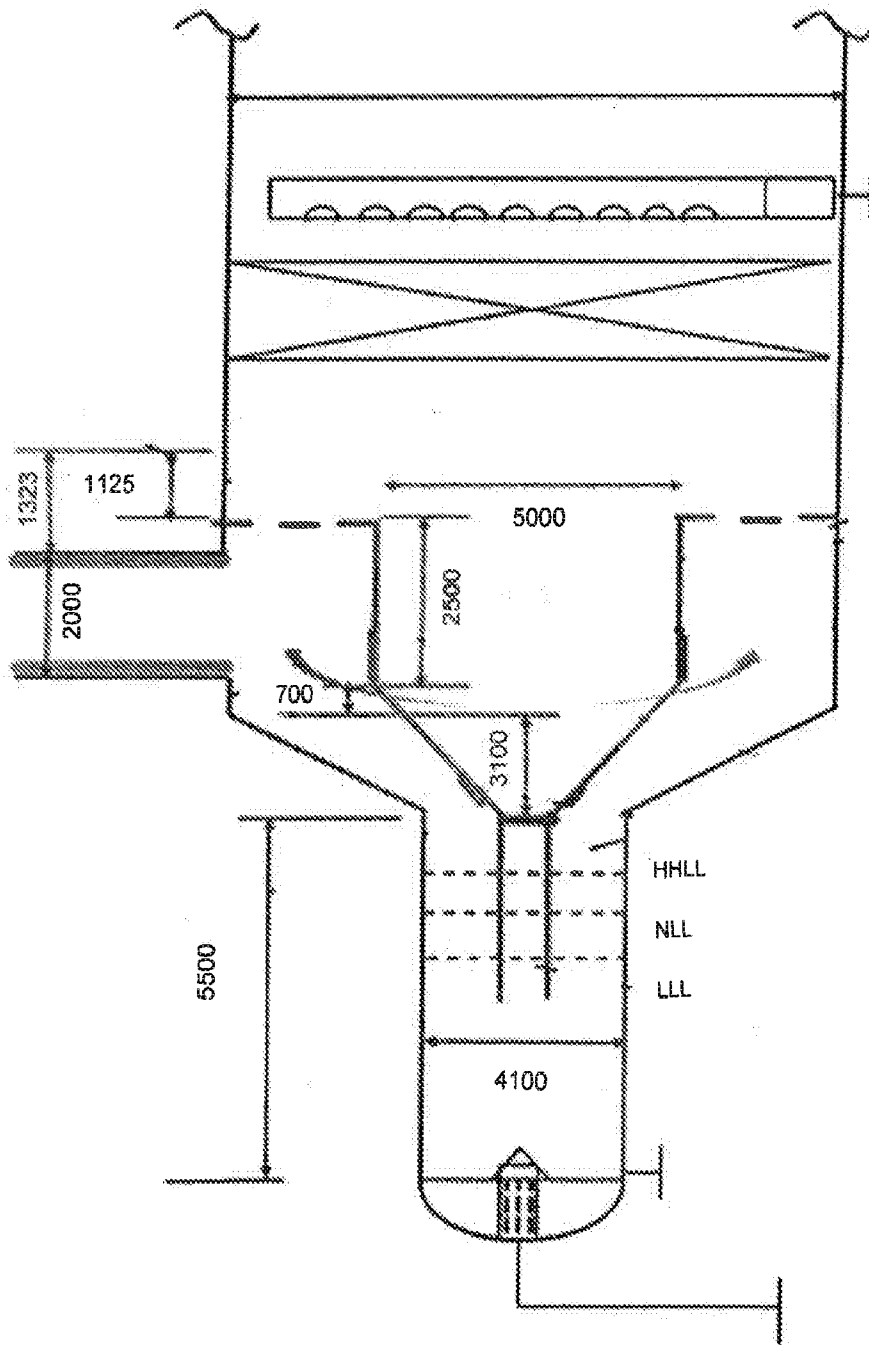

INTERNATIONAL SEARCH REPORT

International application No.

PCT/US 16/14468

A. CLASSIFICATION OF SUBJECT MATTER

IPC(8) - B01F 3/04 (2016.01)

CPC - B01D3/28

According to International Patent Classification (IPC) or to both national classification and IPC

B. FIELDS SEARCHED

Minimum documentation searched (classification system followed by classification symbols)

CPC: B01D3/28

IPC(8): B01F 3/04 (2016.01)

Documentation searched other than minimum documentation to the extent that such documents are included in the fields searched

CPC: B01D3/14 B01D3/16 B01D3/26 B01D3/32 B01D3/18 B01D3/20; IPC(8): B01D19/00 B01D3/14 B01D3/28 (2016.01); USPC: 261/79.2 261/96 261/97 261/98 261/105 261/109 261/110 210787 210788; keyword limited, terms below

Electronic data base consulted during the international search (name of data base and, where practicable, search terms used)

PatBase; Google (Web, Patent, Scholar); terms used: gas vapor steam distributor heat exchange mass transfer column inlet nozzle cone bottom section conform correspond fit superheat contour shell opening annular cylindrical circular circumferential circular flow channel duct conduit chamber compartment corrugate ceiling segment portion division sect

C. DOCUMENTS CONSIDERED TO BE RELEVANT

Category*	Citation of document, with indication, where appropriate, of the relevant passages	Relevant to claim No.
X -- Y	US 2007/0251384 A1 (KURUKCHI et al.) 1 November 2007 (01.11.2007), entire document, especially FIG. 1, 7; para [0003], [0013]-[0016], [0036], [0038], [0040], [0042]-[0043]	1-2, 4-19 ----- 3, 20-28
Y	US 3,917,458 A (POLAK) 4 November 1975 (04.11.1975), entire document, especially FIG. 2;	3, 20.
Y	US 4,351,803 A (OLSON) 28 September 1982 (28.09.1982), entire document, especially Abstract; col. 1, ln. 14-21, col. 1, ln. 65-col. 2, ln.	21-28
Y	US 2015/000524 A1 (DAVYDOV et al.) 1 January 2015 (01.01.2015), entire document, especially FIG. 2, 4; para [0003], [0005]-[0006], [0026]	22-28
A	US 3,916,021 A (HAJEK et al.) 28 October 1975 (28.10.1975), entire document	1-21
A	US 3,348,364 A (HENBY) 24 October 1967 (24.10.1967), entire document	1-21

 Further documents are listed in the continuation of Box C.

* Special categories of cited documents:	“T” later document published after the international filing date or priority date and not in conflict with the application but cited to understand the principle or theory underlying the invention
“A” document defining the general state of the art which is not considered to be of particular relevance	“X” document of particular relevance; the claimed invention cannot be considered novel or cannot be considered to involve an inventive step when the document is taken alone
“E” earlier application or patent but published on or after the international filing date	“Y” document of particular relevance; the claimed invention cannot be considered to involve an inventive step when the document is combined with one or more other such documents, such combination being obvious to a person skilled in the art
“L” document which may throw doubts on priority claim(s) or which is cited to establish the publication date of another citation or other special reason (as specified)	“&” document member of the same patent family
“O” document referring to an oral disclosure, use, exhibition or other means	
“P” document published prior to the international filing date but later than the priority date claimed	

Date of the actual completion of the international search

25 May 2016 (25.05.2016)

Date of mailing of the international search report

09 JUN 2016

Name and mailing address of the ISA/US

Mail Stop PCT, Attn: ISA/US, Commissioner for Patents
P.O. Box 1450, Alexandria, Virginia 22313-1450
Facsimile No. 571-273-8300

Authorized officer:

Lee W. Young

PCT Helpdesk: 571-272-4300
PCT OSP: 571-272-7774

INTERNATIONAL SEARCH REPORT

International application No.

PCT/US 16/14468

Box No. II Observations where certain claims were found unsearchable (Continuation of item 2 of first sheet)

This international search report has not been established in respect of certain claims under Article 17(2)(a) for the following reasons:

1. Claims Nos.:
because they relate to subject matter not required to be searched by this Authority, namely:

2. Claims Nos.:
because they relate to parts of the international application that do not comply with the prescribed requirements to such an extent that no meaningful international search can be carried out, specifically:

3. Claims Nos.:
because they are dependent claims and are not drafted in accordance with the second and third sentences of Rule 6.4(a).

Box No. III Observations where unity of invention is lacking (Continuation of item 3 of first sheet)

This International Searching Authority found multiple inventions in this international application, as follows:
 -see extra sheet-

1. As all required additional search fees were timely paid by the applicant, this international search report covers all searchable claims.
2. As all searchable claims could be searched without effort justifying additional fees, this Authority did not invite payment of additional fees.
3. As only some of the required additional search fees were timely paid by the applicant, this international search report covers only those claims for which fees were paid, specifically claims Nos.:

4. No required additional search fees were timely paid by the applicant. Consequently, this international search report is restricted to the invention first mentioned in the claims; it is covered by claims Nos.:

Remark on Protest

- The additional search fees were accompanied by the applicant's protest and, where applicable, the payment of a protest fee.
- The additional search fees were accompanied by the applicant's protest but the applicable protest fee was not paid within the time limit specified in the invitation.
- No protest accompanied the payment of additional search fees.

-(continuation of first sheet (2)) - Box No. III - Observations where unity of invention is lacking-*

This application contains the following inventions or groups of inventions which are not so linked as to form a single general inventive concept under PCT Rule 13.1. In order for all inventions to be examined, the appropriate additional examination fees must be paid.

Group I: Claims 1-21, directed to a gas distributor for a heat exchanger and/or mass transfer column.

Group II: Claims 22-28, directed to a method of improving feed gas distribution and reducing coke formation in a heat exchange and/or mass transfer column.

The inventions listed as Groups I-V do not relate to a single general inventive concept under PCT Rule 13.1 because, under PCT Rule 13.2, they lack the same or corresponding special technical features for the following reasons:

SPECIAL TECHNICAL FEATURES

The invention of Group I includes the special technical features of a bottom section that extends an interior cylindrical deflector wall and conforms to a contour of a shell wall, and a column sump within a column, not required by the claims of Group II.

The invention of Group II includes the special technical features cooling the superheated feed gas by contacting the gas with a counter current flow of liquid as the liquid passes through the plurality of openings in the ceiling and into the circumferential gas flow channel, wetting the interior cylindrical deflector wall and an interior side of the shell wall that forms the circumferential gas flow channel with the counter current flow of liquid after the liquid has passed through the plurality of ceiling openings, and venting the superheated feed gas to an area above the ceiling and the annular interior area within the column through the at least one opening of the interior cylindrical deflector wall and the plurality of openings in the ceiling to provide a substantially uniform distribution of the superheated feed gas within the column.

COMMON TECHNICAL FEATURES

Groups I-V share the common technical features of a gas distributor comprising a feed gas inlet nozzle extending through a shell wall, a substantially vertical interior cylindrical wall comprising a bottom section and at least one opening to an annular interior open area and, a ceiling above the feed gas inlet nozzle, a circumferential gas flow channel formed between the shell wall, the substantially vertical interior cylindrical wall, and the ceiling, the ceiling having a plurality of openings, and delivering a high velocity superheated feed gas to the gas distributor. However, these shared technical features do not represent a contribution over prior art as being obvious over US 2007/0251384 A1 to Kurukchi et al. (hereinafter 'Kurukchi') in view of US 4,351,803 A to Olson. Kurukchi teaches a gas distributor comprising a feed gas inlet nozzle (FIG. 1; inlet vapor nozzle 16) extending through a shell wall (FIG. 1; column walls 12), a substantially vertical interior cylindrical wall (FIG. 1; interior deflector wall 13) comprising a bottom section and at least one opening (FIG. 1; windows 20) to an annular interior open area (FIG. 1; open column interior 40) and, a ceiling (FIG. 1; ceiling 14) above the feed gas inlet nozzle, a circumferential gas flow channel (FIG. 1; vapor flow channel 11) formed between the shell wall, the substantially vertical interior cylindrical wall, and the ceiling, and the ceiling having a plurality of openings (FIG. 1; chimneys 22), and delivering a high velocity feed gas to the distributor (para [0036], [0043], a multiphase high velocity vapor stream is introduced into the column through a vapor inlet nozzle), but does not explicitly teach a superheated feed gas. However, Olson teaches a superheated feed gas (Abstract; heating a hydrocarbon stream to produce a vapor stream and a liquid stream, superheating the vapor phase, and mixing the superheated vapor phase with a liquid phase to generate a hydrocarbon feed stream). It would have been obvious to a person of ordinary skill in the art to have modified the gas distributor of Kurukchi to supply a superheated feed gas as taught by Olson for better control of the hydrocarbon processing by preventing cracking of heavy hydrocarbons and allowing lighter hydrocarbon cracking (Abstract, col. 1, ln. 14-21, col. 1, ln. 65-col. 2, ln. 3).

Therefore, Groups I and II lack unity under PCT Rule 13 because they do not share a same or corresponding special technical feature.