

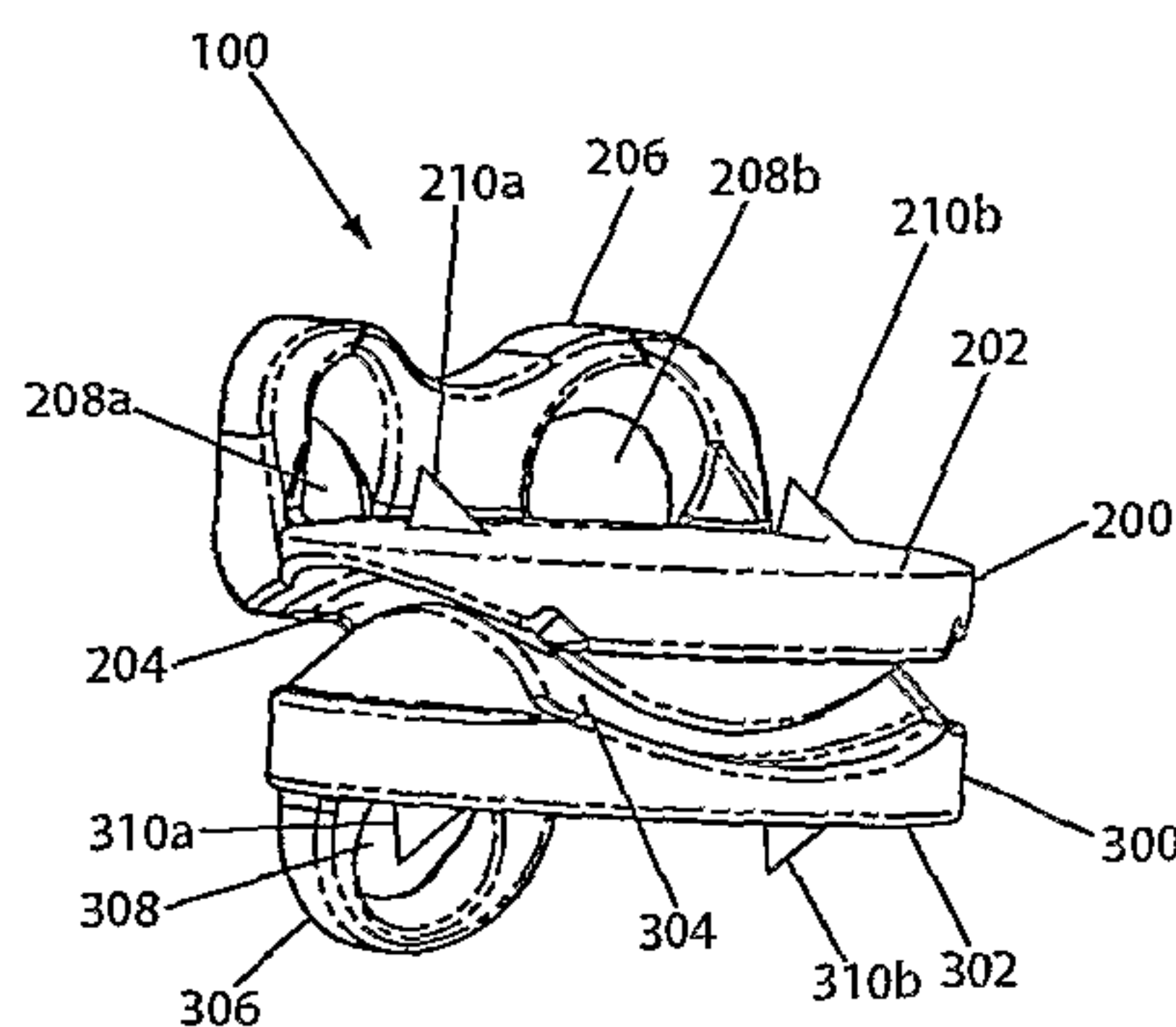

(86) Date de dépôt PCT/PCT Filing Date: 2004/02/11
 (87) Date publication PCT/PCT Publication Date: 2004/09/23
 (85) Entrée phase nationale/National Entry: 2005/09/02
 (86) N° demande PCT/PCT Application No.: US 2004/003966
 (87) N° publication PCT/PCT Publication No.: 2004/080349
 (30) Priorité/Priority: 2003/03/06 (10/382,702) US

(51) Cl.Int.⁷/Int.Cl.⁷ A61F 2/02
 (71) Demandeur/Applicant:
SPINECORE, INC., US
 (72) Inventeurs/Inventors:
ZUBOK, RAFAIL, US;
VALDEVIT, ANTONIO, US;
DUDASIK, MICHAEL W., US;
ERRICO, JOSEPH P., US
 (74) Agent: GOUDREAU GAGE DUBUC

(54) Titre : REMPLACEMENT D'UN DISQUE CERVICAL
 (54) Title: CERVICAL DISC REPLACEMENT



(57) Abrégé/Abstract:

An apparatus (100) for replacing at least a portion of an intervertebral disc in a spinal column includes: a first member (200) having a first vertebral contact surface (202) for engagement with an endplate of a first vertebral bone in the spinal column, and having a first saddle shaped articulation surface (212, 214); and a second member (300) having a second vertebral contact surface (302) for engagement with an endplate of a second vertebral bone in the spinal column, and having a second saddle shaped articulation surface (312, 314), wherein: an intervertebral disc space is defined substantially between the first and second endplates of the first and second vertebral bones, and the first and second articulation surfaces (212, 214, 312, 314) are sized and shaped to engage one another when the first and second members (200, 300) are disposed in the intervertebral disc space to enable the first and second vertebral bones to articulate in at least one of flexion, extension and lateral bending.

(12) INTERNATIONAL APPLICATION PUBLISHED UNDER THE PATENT COOPERATION TREATY (PCT)

(19) World Intellectual Property
Organization
International Bureau



(43) International Publication Date
23 September 2004 (23.09.2004)

PCT

(10) International Publication Number
WO 2004/080349 A1

- (51) International Patent Classification⁷: **A61F 2/02**
- (21) International Application Number:
PCT/US2004/003966
- (22) International Filing Date: 11 February 2004 (11.02.2004)
- (25) Filing Language: English
- (26) Publication Language: English
- (30) Priority Data:
10/382,702 6 March 2003 (06.03.2003) US
- (71) Applicant: **SPINECORE, INC.** [US/US]; 475 Springfield Avenue, 4th Floor, Summit, NJ 07931 (US).
- (72) Inventors: **ZUBOK, Rafail**; 22 Spruce Street, Midland Park, NJ 07432 (US). **VALDEVIT, Antonio**; 1502 Max Way, Fishkill, NY 12524 (US). **DUDASIK, Michael, W.**; 29 Daily Street, Nutley, NJ 07110 (US). **ERRICO, Joseph, P.**; 29 Deer Path Circle, Green Brook, NJ 08812 (US).
- (74) Agent: **DERNIER, Matthew, B.**; Kaplan & Gilman, L.L.P., 900 Route 9 North, Suite 104, Woodbridge, NJ 07095 (US).
- (81) Designated States (*unless otherwise indicated, for every kind of national protection available*): AE, AG, AL, AM, AT, AU, AZ, BA, BB, BG, BR, BW, BY, BZ, CA, CH, CN, CO, CR, CU, CZ, DE, DK, DM, DZ, EC, EE, EG, ES, FI, GB, GD, GE, GH, GM, HR, HU, ID, IL, IN, IS, JP, KE, KG, KP, KR, KZ, LC, LK, LR, LS, LT, LU, LV, MA, MD, MG, MK, MN, MW, MX, MZ, NA, NI, NO, NZ, OM, PG, PH, PL, PT, RO, RU, SC, SD, SE, SG, SK, SL, SY, TJ, TM, TN, TR, TT, TZ, UA, UG, US, UZ, VC, VN, YU, ZA, ZM, ZW.
- (84) Designated States (*unless otherwise indicated, for every kind of regional protection available*): ARIPO (BW, GH, GM, KE, LS, MW, MZ, SD, SL, SZ, TZ, UG, ZM, ZW), Eurasian (AM, AZ, BY, KG, KZ, MD, RU, TJ, TM), European (AT, BE, BG, CH, CY, CZ, DE, DK, EE, ES, FI, FR, GB, GR, HU, IE, IT, LU, MC, NL, PT, RO, SE, SI, SK, TR), OAPI (BF, BJ, CF, CG, CI, CM, GA, GN, GQ, GW, ML, MR, NE, SN, TD, TG).
- Published:**
— with international search report
— before the expiration of the time limit for amending the claims and to be republished in the event of receipt of amendments
- For two-letter codes and other abbreviations, refer to the "Guidance Notes on Codes and Abbreviations" appearing at the beginning of each regular issue of the PCT Gazette.*

(54) Title: CERVICAL DISC REPLACEMENT

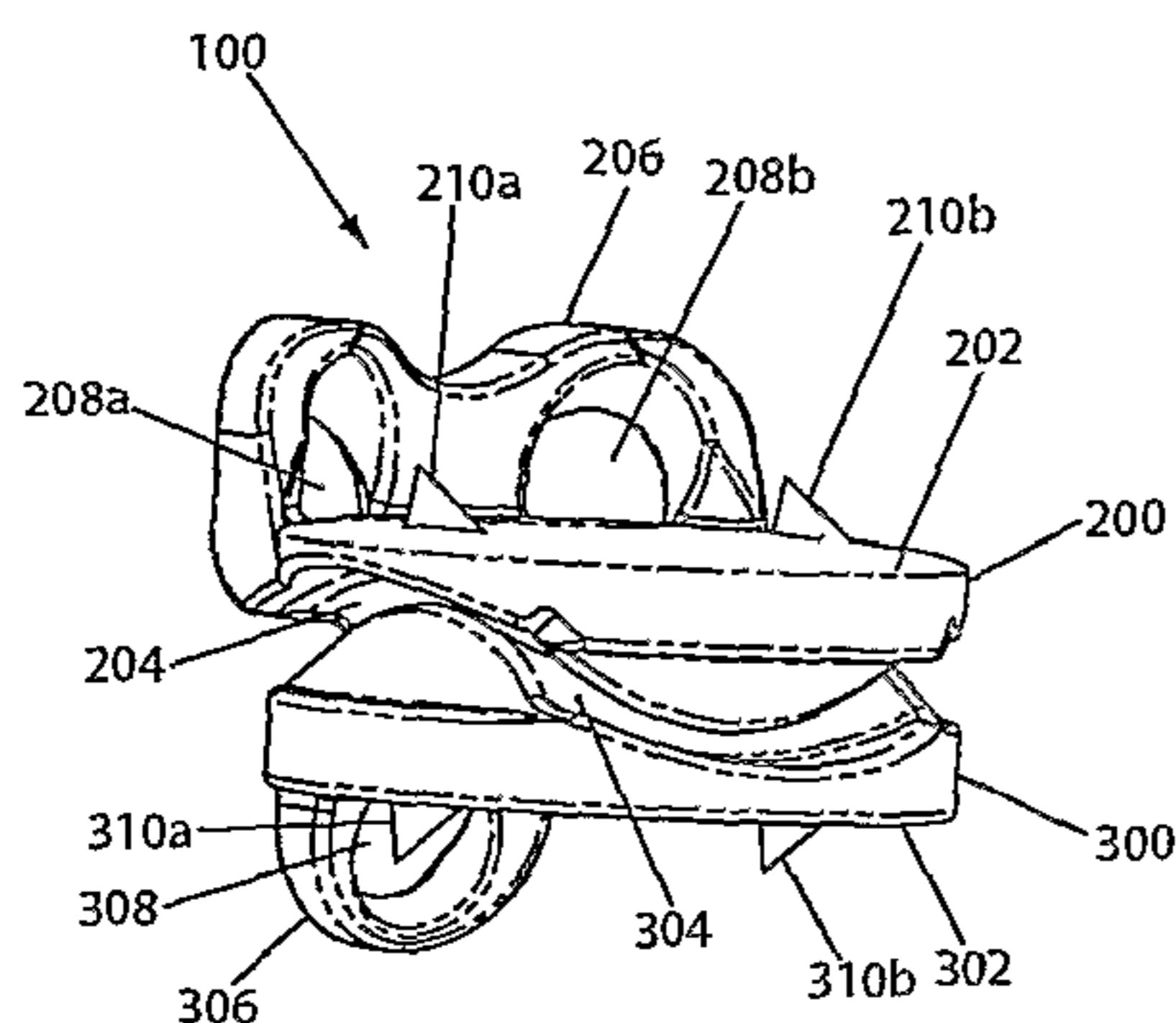

(57) Abstract: An apparatus (100) for replacing at least a portion of an intervertebral disc in a spinal column includes: a first member (200) having a first vertebral contact surface (202) for engagement with an endplate of a first vertebral bone in the spinal column, and having a first saddle shaped articulation surface (212, 214); and a second member (300) having a second vertebral contact surface (302) for engagement with an endplate of a second vertebral bone in the spinal column, and having a second saddle shaped articulation surface (312, 314), wherein: an intervertebral disc space is defined substantially between the first and second endplates of the first and second vertebral bones, and the first and second articulation surfaces (212, 214, 312, 314) are sized and shaped to engage one another when the first and second members (200, 300) are disposed in the intervertebral disc space to enable the first and second vertebral bones to articulate in at least one of flexion, extension and lateral bending.

WO 2004/080349 A1

CERVICAL DISC REPLACEMENT

Technical Field

The present invention is directed to a cervical joint replacement implant and more particularly to a cervical intervertebral disc prosthesis having opposing constant radii saddle shaped articulating surfaces.

Background Art

The structure of the intervertebral disc disposed between the cervical bones in the human spine comprises a peripheral fibrous shroud (the annulus) which circumscribes a spheroid of flexibly deformable material (the nucleus). The nucleus comprises a hydrophilic, elastomeric cartilaginous substance that cushions and supports the separation between the bones while also permitting articulation of the two vertebral bones relative to one another to the extent such articulation is allowed by the other soft tissue and bony structures surrounding the disc. The additional bony structures that define pathways of motion in various modes include the posterior joints (the facets) and the lateral intervertebral joints (the unco-vertebral joints). Soft tissue components, such as ligaments and tendons, constrain the overall segmental motion as well.

Traumatic, genetic, and long term wearing phenomena contribute to the degeneration of the nucleus in the human spine. This degeneration of this critical disc material, from the hydrated, elastomeric material that supports the separation and flexibility of the vertebral bones, to a flattened and inflexible state, has profound effects on the mobility (instability and limited ranges of appropriate motion) of the segment, and can cause significant pain to the individual suffering from the condition. Although the specific causes of pain in patients suffering from degenerative disc disease of the cervical spine have not been definitively established, it has been recognized that pain may be the result of neurological implications (nerve fibers being compressed) and/or the subsequent degeneration of the surrounding tissues (the arthritic degeneration of the facet joints) as a result of their being overloaded.

Traditionally, the treatment of choice for physicians caring for patients who suffer from significant degeneration of the cervical intervertebral disc is to remove some, or all, of the damaged disc. In instances in which a sufficient portion of the intervertebral disc material is removed, or in which much of the necessary spacing

between the vertebrae has been lost (significant subsidence), restoration of the intervertebral separation is required.

Unfortunately, until the advent of spine arthroplasty devices, the only methods known to surgeons to maintain the necessary disc height necessitated the immobilization of the segment. Immobilization is generally achieved by attaching metal plates to the anterior or posterior elements of the cervical spine, and the insertion of some osteoconductive material (autograft, allograft, or other porous material) between the adjacent vertebrae of the segment. This immobilization and insertion of osteoconductive material has been utilized in pursuit of a fusion of the bones, which is a procedure carried out on tens of thousands of pain suffering patients per year.

This sacrifice of mobility at the immobilized, or fused, segment, however, is not without consequences. It was traditionally held that the patient's surrounding joint segments would accommodate any additional articulation demanded of them during normal motion by virtue of the fused segment's immobility. While this is true over the short-term (provided only one, or at most two, segments have been fused), the effects of this increased range of articulation demanded of these adjacent segments has recently become a concern. Specifically, an increase in the frequency of returning patients who suffer from degeneration at adjacent levels has been reported.

Whether this increase in adjacent level deterioration is truly associated with rigid fusion, or if it is simply a matter of the individual patient's predisposition to degeneration is unknown. Either way, however, it is clear that a progressive fusion of a long sequence of vertebrae is undesirable from the perspective of the patient's quality of life as well as from the perspective of pushing a patient to undergo multiple operative procedures.

While spine arthroplasty has been developing in theory over the past several decades, and has even seen a number of early attempts in the lumbar spine show promising results, it is only recently that arthroplasty of the spine has become a truly realizable promise. The field of spine arthroplasty has several classes of devices. The most popular among these are: (a) the nucleus replacements, which are characterized by a flexible container filled with an elastomeric material that can mimic the healthy nucleus; and (b) the total disc replacements, which are designed with rigid endplates which house a mechanical articulating structure that attempts to mimic and promote the healthy segmental motion.

Among these solutions, the total disc replacements have begun to be regarded as the most probable long-term treatments for patients having moderate to severe lumbar disc degeneration. In the cervical spine, it is likely that these mechanical solutions will also become the treatment of choice. At present, there are two devices being tested clinically in humans for the indication of cervical disc degeneration. The first of these is the Bryan disc, disclosed in part in US Patent Number 6,001,130. The Bryan disc is comprised of a resilient nucleus body disposed in between concaval-covex upper and lower elements that retain the nucleus between adjacent vertebral bodies in the spine. The concaval-convex elements are L-shaped supports that have anterior wings that accept bones screws for securing to the adjacent vertebral bodies.

The second of these devices being clinically tested is the Bristol disc, disclosed substantially in US Patent Number 6,113,637. The Bristol disc is comprised of two L-shaped elements, with corresponding ones of the legs of each element being interposed between the vertebrae and in opposition to one another. The other of the two legs are disposed outside of the intervertebral space and include screw holes through which the elements may be secured to the corresponding vertebra; the superior element being secured to the upper vertebral body and the inferior element being attached to the lower vertebral body. The opposing portions of each of the elements comprise the articulating surfaces that include an elliptical channel formed in the lower element and a convex hemispherical structure disposed in the channel.

As is evident from the above descriptions, the centers of rotation for both of these devices, which are being clinically tested in human subjects, is disposed at some point in the disc space. More particularly with respect to the Bryan disc, the center of rotation is maintained at a central portion of the nucleus, and hence in the center of the disc space. The Bristol disc, as a function of its elongated channel (its elongated axis being oriented along the anterior to posterior direction), has a moving center of rotation which is, at all times maintained within the disc space at the rotational center of the hemispherical ball (near the top of the upper element).

The uses, features and advantages of the invention not explicitly stated will be set forth and will be more clearly understood in conjunction with the descriptions of the embodiments disclosed hereafter.

Summary Of The Invention

The above objects are achieved by the present invention, which provides an articulating joint implant that includes a pair of opposing upper and lower elements having nested articulation surfaces providing a center of rotation of the implant above the adjacent vertebral body endplate surfaces in one mode of motion (e.g., lateral bending) and a center of rotation of the implant below those surfaces in another mode of motion (e.g., flexion/extension), and that further permit axial rotation of the opposing elements relative to one another (for example, about an axis such as, for example, a longitudinal axis, for example, of the spinal column)) through a range of angles without causing them to move in directions that are directed away from one another (for example, in opposing directions along the axis of axial rotation) within that range. In preferred embodiments, the articulation surfaces further cause such opposite (or otherwise directed away from one another) movement of the opposing elements beyond that range.

More particularly, the present invention contemplates that with regard to the cervical anatomy, a device that maintains a center of rotation, moving or otherwise, within the disc space is inappropriate and fails to properly support healthy motion. Specifically, the cervical joint comprises five separate articulating elements: the facet joints in the posterior of the segment; the lateral unco-vertebral joints; and the nucleus in the intervertebral space. It is contemplated by the present invention that a track defined by the cervical facets falls along the planes between the inferior surface of the upper facets and the superior surface of the lower facets, and that this plane extends upwardly and forward, forcing the overall joint to pivot around a center of rotation that resides in the lower vertebral bone in flexion/extension articulation.

Conversely, it is contemplated by the present invention that in lateral bending the unco-vertebral joints influence the track of motion. Specifically, the unco-vertebral joints are formed at the lateral edges of the intervertebral space and are defined by a pair of upwardly extending surfaces of the inferior vertebral endplate and the corresponding surfaces of the superior bony endplate. It is contemplated by the present invention that this U-shaped configuration guides the segment into a rotation about a center within the superior vertebral bone during lateral bending.

Finally, it is contemplated by the present invention that during axial rotation of the adjacent vertebral bones of the cervical segment relative to one another about the longitudinal axis of the spinal column, the opposing bones do not simply axially rotate

relative to one another for more than a few degrees, but rather follow the coupled influences of the unco-vertebral joints and the nucleus, and that this coupled motion vertically separates the opposing bones of the facet joints as the rotation continues, thus freeing the bones to rotate farther than would otherwise be permitted if the facets locked together (as is often seen as a symptom of degenerative cervical disease).

Both the Bryan and Bristol discs described above do provide distraction and maintenance of intervertebral disc height, and thereby provide immediate and short-term relief from pain. However, it should be understood, in light of the above described anatomy as contemplated by the present invention, that neither provides for proper anatomical motion because their respective centers of rotation are located within the disc space. Thus, neither will afford significant motion preservation, and patients with these devices implanted in their necks will find no significant mobility at the implanted segment. This may lead to spontaneous fusions, long term facet deterioration, and/or accelerated adjacent level degeneration.

The constraints placed on the prosthesis by the above-described anatomy are considerable. To provide an implant having a pair of articulation surfaces that provide a center of rotation of the implant above the surfaces in one mode of motion (lateral bending) and a center of rotation of the implant below the surfaces in another mode of motion (flexion/extension), that further permit the surfaces to axially rotate relative to one another about a longitudinal axis of the spinal column through a range of angles without causing movement of the surfaces in opposing directions along the longitudinal axis of the spinal column, and that further cause such movement (and accordingly a vertical separation of the facet joints) beyond that range is a difficult engineering task. The present invention contemplates that a saddle joint provides a geometric approach to the task.

The solution to this problem, however, is not open to any saddle joint configuration. US Patent Numbers 5,405,400 and 5,645,605 describe saddle joints utilized for prosthetic thumb joints. More particularly, US Patent Number 5,405,400 ("Linscheid") discloses an artificial thumb joint comprising a pair of surfaces that are nesting hyperbolic paraboloids. A hyperbolic paraboloid is a surface defined by a first specific geometric form (the hyperbola) that is swept along a second geometric form (the parabola) that is perpendicular to the first form, and which first and second forms are opposite in the direction of their convexities. A common feature of both hyperbolae and parabolae is that neither has a constant radius of curvature along its

extent. Constant radii of curvature are necessary for a pair of surfaces to smoothly flow over one another. Accordingly, the nesting hyperbolic paraboloids set forth in the reference are, therefore, not capable of any smooth articulation. Any attempted articulation causes the two surfaces to immediately move in opposing directions. Stated more simply, nesting hyperbolic paraboloids have continuously changing centers of rotation (by the nature of the geometric forms selected). The present invention contemplates that the cervical joint anatomy enables smooth articulation in two modes of motion (lateral bending and flexion/extension), and also smooth relative axial rotation about the longitudinal axis of the spinal column through a small range of angles. It is understood by the present invention that the vertical separation motion of the natural cervical joint does not occur immediately, but rather occurs only outside that small angular range of relative axial rotation. Thus, the present invention contemplates that the nesting hyperbolic paraboloids disclosed by Linscheid are inappropriate for use in the cervical joint.

US Patent Number 5,645,605 ("Klawitter") discloses an alternate form of a saddle surface, again for use in an artificial thumb joint, that comprises a pair of nesting toroidal surfaces. Toroidal surfaces are defined by an arc of one circle being swept along an arc of another, again having opposing convexities. As circles have constant radii of curvatures, it is possible with these surfaces to have smooth motion in two perpendicular planes. More particularly, if the corresponding radii of curvature are approximately equivalent, the two surfaces may nest and articulate in flexion/extension and lateral bending smoothly, without causing the surfaces to move in opposing directions upon an attempted articulation. However, Klawitter teaches that these toroidal surfaces should have the same radii of curvature, inasmuch as it is a necessity that axial rotational motion of the joint be inhibited, or if it is permitted to occur, it should cause an immediate axial distraction of the joint. As explained above with regard to the saddle joint in Linscheid, this elimination of the capacity of the surfaces to axially rotate relative to one another for even a small range of angles prevents such a design from being effectively used in a cervical disc application.

In order for two nesting toroidal saddles to rotate within the same plane, each of the concave radii of the surfaces must be greater than the radius of its nested convex surface. An artificial cervical joint that provides a center of rotation in the vertebral bone below during flexion/extension and in the vertebral bone above during lateral bending and has the capacity to axially rotate within a small range of angles

prior to causing oppositely directed movement of the surfaces requires nesting surfaces with such a configuration.

The present invention, therefore, provides an articulating joint implant for use in the cervical spine, including a first (e.g., upper) element and a second (e.g., lower) element, each having an outwardly facing vertebral body contact surface, and each having an inwardly facing articulation surface. The elements are disposed with the articulation surfaces nested against one another, and the vertebral body contact surfaces facing away from one another. When the implant is disposed in an intervertebral disc space in a cervical spine, in this configuration and with the vertebral body contact surfaces engaged with respective adjacent vertebral body endplates, the implant enables the adjacent vertebral bones to move relative to one another in accordance with proper anatomical motion.

Preferably, each of the elements has at least one long-term fixation structure (e.g., a flange) having at least one feature (e.g., a through hole) for securing the element to an adjacent vertebral body. For example, the upper element has an anterior flange that extends upwardly and has two through holes, each of which accepts a bone screw. And, for example, the lower element has an anterior flange that extends downwardly and has one through hole that accepts a bone screw. Further preferably, each of the elements has at least one short-term fixation structure (e.g., spikes on the outwardly directed vertebral body contact surface) for securing the element to an adjacent vertebral body endplate.

Further preferably, each of the outwardly directed vertebral body contact surfaces is shaped to conform to the endplate of an adjacent vertebral body against which it is to be positioned. For example, vertebral body contact surface of the upper element is curvate (to match the anatomy of the superior vertebral body endplate) and the vertebral body contact surface of the lower element is flat (to match the anatomy of the inferior vertebral body endplate). Further preferably, each vertebral body contact surface has an osteoinductive or osteoconductive feature, such as, for example, porous or rough areas.

The longitudinally inwardly directed articulation surface of the upper element forms a constant radii saddle-shaped articulation surface. More particularly, the saddle surface is defined by a concave arc that is swept perpendicular to and along a convex arc. The articulation surface has a cross-section in one plane that forms a concave arc, and a cross-section in another plane (perpendicular to that plane) that

forms a convex arc. The concave arc has a respective constant radius of curvature about an axis perpendicular to the one plane. The convex arc has a respective constant radius of curvature about an axis perpendicular to the other plane.

In a preferred embodiment, the concave arc has a constant radius of curvature A about an axis perpendicular to the anterior-posterior plane, and the convex arc has a constant radius of curvature B about an axis perpendicular to the lateral plane. Preferably, radius A is less than radius B.

The longitudinally inwardly directed articulation surface of the lower element also forms a constant radii saddle-shaped articulation surface. More particularly, the saddle surface is defined by a convex arc that is swept perpendicular to and along a concave arc. The articulation surface has a cross-section in one plane that forms a convex arc, and a cross-section in another plane (perpendicular to that plane) that forms a concave arc. The convex arc has a respective constant radius of curvature about an axis perpendicular to the one plane. The concave arc has a respective constant radius of curvature about an axis perpendicular to the other plane.

In a preferred embodiment, the convex arc has a constant radius of curvature C about an axis perpendicular to the anterior-posterior plane, and the concave arc has a constant radius of curvature D about an axis perpendicular to the lateral plane. Preferably, radius C is less than radius D.

The constant radii saddle shaped articulation surfaces are configured and sized to be nestable against one another and articulatable against one another, to enable adjacent vertebral bones (against which the upper and lower elements are respectively disposed in the intervertebral space) to articulate in flexion, extension, and lateral bending. More particularly, the artificial disc implant of the present invention is assembled by disposing the upper and lower elements such that the vertebral body contact surfaces are directed away from one another, and the articulation surfaces are nested against one another such that the concave arcs accommodates the convex arcs.

Accordingly, movement of the adjacent vertebral bones relative to one another is permitted by the movement of the upper and lower elements relative to one another. In flexion and extension, the concave arcs of the upper element ride on the convex arcs of the lower element about a center of rotation below the articulation surfaces. In lateral bending, the concave arcs of the lower element ride on the convex arcs of the upper element about a center of rotation above the articulation surfaces. During these articulations, the elements are maintained at constant relative distraction positions, i.e.,

the elements do not move in directions that are directed away from one another (for example, do not move in opposing axial directions from one another (e.g., along a longitudinal axis of the spine)). Accordingly, the present invention provides a pair of articulation surfaces that have a center of rotation above the surfaces in one mode of motion (lateral bending), and below the surfaces in another (flexion/extension), consistent in these regards with a natural cervical intervertebral joint. Preferably, the articulation surfaces are sized and configured so that the respective ranges of angles through which flexion/extension and lateral bending can be experienced are equal to or greater than the respective normal physiologic ranges for such movements in the cervical spine.

It is preferable that, in addition to the flexion, extension, and lateral bending motions described above, the adjacent vertebral bones be permitted by the artificial disc implant to axially rotate relative to one another (e.g., about the longitudinal axis of the spinal column), through a small range of angles, without moving in opposite (or otherwise directed away from one another) directions (e.g., along the longitudinal axis) within that range, and then to engage in such opposite (or otherwise directed away from one another) movement once that range is exceeded. Preferably, the articulation surfaces 204, 304 are accordingly configured and sized to permit such movements. In a preferred configuration, the constant radius of curvature A is larger than the constant radius of curvature C, and the constant radius of curvature D is larger than the constant radius of curvature B. Because of the space, afforded by the differing radii, at the edges of the articulation surfaces, the upper and lower elements are able to axially rotate relative to one another about the longitudinal axis of the spinal column through a range of angles without causing the vertebral body contact surfaces to move away from one another along the longitudinal axis. Once the axial rotation exceeds that range, the articulation surfaces interfere with one another as the concave arcs move toward positions in which they would be parallel to one another, and the distance between the vertebral body contact surfaces increases with continued axial rotation as the concave arcs ride up against their oppositely directed slopes. Thus, the articulation surfaces are configurable according to the present invention to permit normal physiologic axial rotational motion of the adjacent vertebral bones about the longitudinal axis through a range of angles without abnormal immediate axially opposite (or otherwise directed away from one another) movement, and to permit such axially opposite (or otherwise directed away from one another)

movement when under normal physiologic conditions it should occur, that is, outside that range of angles.

In preferred embodiments where the constant radius of curvature A is larger than the constant radius of curvature C, and the constant radius of curvature D is larger than the constant radius of curvature B, the articulation surfaces maintain point-to-point contact over a range of normal physiologic articulating movement between the adjacent vertebral bones. That is, through flexion, extension, lateral bending, and axial rotation, the articulation surfaces are in point-to-point contact with one another.

Preferably, the surface area dimensions of the articulation surfaces are selected in view of the selected radii of curvature to prevent the edges of the saddle surfaces (particularly the edges of the concave arcs) from hitting any surrounding anatomic structures, or other portions of the opposing upper or lower element, before the limit of the normal physiologic range of an attempted articulation is reached.

The novel features of the present invention, as well as the invention itself, both as to its structure and its operation will be understood from the accompanying drawings, taken in conjunction with the accompanying description, in which similar reference characters refer to similar parts throughout.

Brief Description Of The Drawings

Figures 1-5 show an artificial disc implant of the present invention in perspective, anterior, lateral, lateral cutaway, and posterior cutaway views, respectively.

Figures 6-12 show an upper element of the artificial disc implant of Figures 1-5 in perspective, bottom (looking longitudinally up), lateral, anterior, lateral cutaway, top (looking longitudinally down), and posterior cutaway views, respectively.

Figures 13-19 show a lower element of the artificial disc implant of Figures 1-5 in perspective, top (looking longitudinally down), lateral, anterior, lateral cutaway, bottom (looking longitudinally up), and posterior cutaway views, respectively.

Figure 20 shows a lateral cross-section view of the artificial disc implant of Figures 1-5 in extension.

Figure 21 shows a posterior cross-section view of the artificial disc implant of Figures 1-5 in lateral bending.

Best Mode Of Carrying Out Invention

For the purposes of promoting an understanding of the principles of the invention, reference will now be made to the embodiment illustrated in the drawings and specific language will be used to describe the same. It will nevertheless be understood that no limitation of the scope of the invention is thereby intended, such alterations and further modifications in the illustrated device, and such further applications of the principles of the invention as illustrated therein, being contemplated as would normally occur to one skilled in the art to which the invention relates.

Referring now to Figures 1-5, an artificial disc implant 100 of the present invention is shown in perspective, anterior, lateral, lateral cutaway, and posterior cutaway views, respectively. The implant 100 includes a first (e.g., upper) element 200 and a second (e.g., lower) element 300, each having an outwardly facing vertebral body contact surface 202, 302, and each having an inwardly facing articulation surface 204, 304. The elements 200, 300 are disposed as shown with the articulation surfaces 204, 304 nested against one another, and the vertebral body contact surfaces 202, 302 facing away from one another. When the implant 100 is disposed in an intervertebral disc space in a cervical spine, in this configuration and with the vertebral body contact surfaces 202, 302 engaged with respective adjacent vertebral body endplates (not shown), the implant 100 enables the adjacent vertebral bones to move relative to one another in accordance with proper anatomical motion, as further described below.

Preferably, at least one (and more preferably both) of the elements 200, 300 has at least one long-term fixation structure (e.g., flange 206, 306) having at least one feature (e.g., through hole 208a, 208b, 308) for securing the element to an adjacent vertebral body. For example, the upper element 200 has an anterior flange 206 that extends upwardly and has two through holes 208a, 208b, each of which accepts a bone screw (not shown). And, for example, the lower element 300 has an anterior flange 306 that extends downwardly and has one through hole 308 that accepts a bone screw (not shown). Once the elements 200, 300 are disposed in the intervertebral space with the vertebral body contact surfaces 202, 302 engaged with respective adjacent vertebral body endplates (not shown), securing of bone screws through the holes 208a, 208b, 308 and into the anterior surfaces of the adjacent vertebral bones helps prevent the elements from becoming dislodged from, or displaced in, the

intervertebral space. Preferably, the bore axes of the through holes 208a, 208b, 308 are angled toward the adjacent vertebral body as shown.

Further preferably, at least one (and more preferably both) of the elements 200, 300 has at least one short-term fixation structure (e.g., spike 210a, 210b, 310a, 310b) for securing the element to an adjacent vertebral body (and more preferably to an adjacent vertebral body endplate). For example, each of the elements 200, 300 has a respective pair of outwardly directed spikes 210a, 210b, 310a, 310b. Once the elements 200, 300 are disposed in the intervertebral space with the vertebral body contact surfaces 202, 302 engaged with respective adjacent vertebral body endplates (not shown), the spikes 210a, 210b, 310a, 310b dig into the adjacent vertebral body endplates under the compression along the longitudinal axis of the spinal column, and thus help prevent the elements from becoming dislodged from, or displaced in, the intervertebral space. Preferably, each of the spikes 210a, 210b, 310a, 310b is sloped toward the vertebral body contact surface 202, 302 and toward the posterior direction on its posterior side as shown, to facilitate ease of insertion of the implant 100 into the intervertebral space, and is either perpendicular to the vertebral body contact surface 202, 302 on its anterior side (as shown) or sloped toward the vertebral body contact surface 202, 302 and toward the posterior direction on its anterior side (not shown), to help prevent the elements 200, 300 from anteriorly (or otherwise) slipping out of the intervertebral space.

More particularly, and referring now to Figures 6-12, the upper element 200 of the artificial disc implant 100 shown in Figures 1-5 is shown in perspective, bottom (looking longitudinally up), lateral, anterior, lateral cutaway, top (looking longitudinally down), and posterior cutaway views, respectively. Further particularly, and referring now to Figures 13-19, the lower element 300 of the artificial disc implant 100 shown in Figures 1-5 is shown in perspective, top (looking longitudinally down), lateral, anterior, lateral cutaway, bottom (looking longitudinally up), and posterior cutaway views, respectively.

As introduced above, each of the elements 200, 300 has a longitudinally outwardly directed vertebral body contact surface 202, 302. Preferably, each surface 202, 302 is shaped to conform to an endplate of an adjacent vertebral body (not shown) against which it is to be positioned. For example, inasmuch as a review of the relevant anatomy indicates that lower endplates of vertebral bones in the cervical spine each have a central concavity, it is preferable that the surface 202 is curvate

(and more preferably, domed as shown, or semi-cylindrical), to conform to the central concavity. And, for example, inasmuch as a review of the relevant anatomy indicates that upper endplates of vertebral bones in the cervical spine are generally flat, it is preferable that the surface 302 is flat, as shown. It should be understood that the surfaces 202, 302 can be formed or can be dynamically formable to have these or other shapes that closely conform to the adjacent vertebral body endplate, without departing from the scope of the present invention.

Each vertebral body contact surface 202, 302 further preferably has an osteoinductive or osteoconductive feature. For example, each surface 202, 302 is preferably porous and/or roughened. This can be accomplished by any manner known in the art, including, for example, grit blasting, porous coating, etching, burning, electrical discharge machining, and sintered beading. While both surfaces 202, 302 are preferably provided with such a feature, it should be understood that only one could have such a feature without departing from the scope of the present invention. Further, it should be understood that it is not necessary for the entire surface to be so featured, but rather only a portion, some portions, or all of the surface can be so featured, or have a variety of such features, without departing from the scope of the present invention.

Each vertebral body contact surface 202, 302 further preferably has the long-term fixation and short-term fixation structures described above and denoted by corresponding reference numbers on these Figures 6-19.

As introduced above, the upper element 200 has a longitudinally inwardly directed articulation surface 204. Preferably, as shown, the articulation surface 204 includes a saddle surface that is defined by a concave arc (denoted by reference numeral 212 on Figure 10) that is swept perpendicular to and along a convex arc (denoted by reference numeral 214 on Figure 12). As best seen in Figures 4, 5, 10, and 12, the articulation surface 204 has a cross-section in one plane that forms a concave arc 212, and a cross-section in another plane (perpendicular to that plane) that forms a convex arc 214. The concave arc 212 has a respective constant radius of curvature about an axis perpendicular to the one plane. The convex arc 214 has a respective constant radius of curvature about an axis perpendicular to the other plane. Therefore, the articulation surface 204 forms a constant radii saddle-shaped articulation surface.

In this preferred embodiment, as indicated in Figure 10, the concave arc 212 has a constant radius of curvature A about an axis perpendicular to the anterior-posterior plane. And, in this preferred embodiment, as indicated in Figure 12, the convex arc 214 has a constant radius of curvature B about an axis perpendicular to the lateral plane. Preferably, radius A is less than radius B, and most preferably, radius A is 0.329 and radius B is 0.340. It should be noted, however, that the present invention is not limited to any particular dimension set, and further than in some embodiments of the present invention, radius A is equal to or greater than radius B.

Also as introduced above, the lower element 300 has a longitudinally inwardly directed articulation surface 304. Preferably, as shown, the articulation surface 304 includes a saddle surface that is defined by a convex arc (denoted by reference numeral 312 on Figure 17) that is swept perpendicular to and along a concave arc (denoted by reference numeral 314 on Figure 19). As best seen in Figures 4, 5, 17, and 19, the articulation surface 304 has a cross-section in one plane that forms a convex arc 312, and a cross-section in another plane (perpendicular to that plane) that forms a concave arc 314. The convex arc 312 has a respective constant radius of curvature about an axis perpendicular to the one plane. The concave arc 314 has a respective constant radius of curvature about an axis perpendicular to the other plane. Therefore, the articulation surface 304 also forms a constant radii saddle-shaped articulation surface.

In this preferred embodiment, as indicated in Figure 17, the convex arc 312 has a constant radius of curvature C about an axis perpendicular to the anterior-posterior plane. And, in this preferred embodiment, as indicated in Figure 19, the concave arc 314 has a constant radius of curvature D about an axis perpendicular to the lateral plane. Preferably, radius C is less than radius D, and most preferably, radius C is 0.280 inches and radius D is 0.401 inches. It should be noted, however, that the present invention is not limited to any particular dimension set, and further than in some embodiments of the present invention, radius C is equal to or greater than radius D. Further in some embodiments, radii A, B, C, and D are of equal dimension.

Importantly, the constant radii saddle shaped articulation surfaces 204, 304 are configured and sized to be nestable against one another and articulatable against one another, to enable adjacent vertebral bones (against which the upper and lower elements 200, 300 are respectively disposed in the intervertebral space) to articulate in

flexion, extension, and lateral bending. More particularly, as best shown in Figures 1-5, the artificial disc implant 100 of the present invention is assembled by disposing the upper 200 and lower 300 elements such that the vertebral body contact surfaces 202, 302 are directed away from one another, and the articulation surfaces 204, 304 are nested against one another such that the concave arc 212 accommodates the convex arc 312 and such that the convex arc 214 is accommodated by the concave arc 314. Either during or after such assembly of the implant 100, the vertebral body contact surface 202 of the upper element 200 is fixed against a lower endplate of a superior vertebral body (not shown), and the vertebral body contact surface 302 of the lower element 300 is fixed against an upper endplate of an inferior vertebral body (not shown). As noted above, the preferable long-term and short-term fixation structures on the elements 200, 300 are useful for securing the elements 200, 300 to these adjacent vertebral bones.

Accordingly, movement of the adjacent vertebral bones relative to one another is permitted by the movement of the upper 200 and lower 300 elements relative to one another. With regard to the articulation surfaces 204, 304 being configured and sized to enable the adjacent vertebral bones to articulate in flexion, extension, and lateral bending, it is understood from the described geometry and positioning of the upper 200 and lower 300 elements once the implant 100 is assembled and implanted that in flexion and extension, the concave arcs (e.g., 212) of the upper element 200 ride on the convex arcs (e.g., 312) of the lower element 300 about a center of rotation (referenced as R3 on Figure 18) at the center of the circle defined by the convex arc 312. This center of rotation R3 is below the articulation surface 304. It is further understood from the described geometry and positioning of the upper 200 and lower 300 elements that in lateral bending, the concave arcs (e.g., 314) of the lower element 300 ride on the convex arcs (e.g., 214) of the upper element 200 about a center of rotation (referenced as R2 on Figure 12) at the center of the circle defined by the convex arc 214. This center of rotation R2 is above the articulation surface 204. During these articulations, the elements 200, 300 are maintained at constant relative distraction positions, i.e., the elements 200, 300 do not move in directions that are directed away from one another (for example, do not move in opposing axial directions from one another (e.g., along the longitudinal axis of the spine)). Accordingly, the present invention provides a pair of articulation surfaces 204, 304 that have a center of rotation above the surfaces in one mode of motion (lateral

bending), and below the surfaces in another (flexion/extension), consistent in these regards with a natural intervertebral joint in the cervical spine. Preferably, the articulation surfaces 204, 304 are sized and configured so that the respective ranges of angles through which flexion/extension and lateral bending can be experienced are equal to or greater than the respective normal physiologic ranges for such movements in the cervical spine. While the present invention is not limited to any particular dimensions, a preferred embodiment has the following radii of curvature for the convex arc 312 and the convex arc 214: $C = 0.280$ inches and $B = 0.340$ inches. Such preferable radii of curvature provide the preferred embodiment with a flexion/extension range of plus or minus 7.5 degrees (total of 15 degrees), and a lateral bending range of plus or minus 7.5 degrees (total of 15 degrees).

While the preferred embodiment is shown with concave arc 212 having a larger constant radius of curvature A than the constant radius of curvature C of convex arc 312 (for reasons that are described in detail below), and with concave arc 314 having a larger constant radius of curvature D than the constant radius of curvature B of convex arc 214 (for reasons that are described in detail below), it should be understood that the above described functionality can also be achieved using other relative radii sizes. For example, flexion, extension, and lateral bending are also possible if the constant radius of curvature A of concave arc 212 is otherwise non-congruent with (e.g., less than) or is congruent with (i.e., equal to) the constant radius of curvature C of convex arc 312, and/or if the constant radius of curvature D of concave arc 314 is otherwise non-congruent with (e.g., less than) or is congruent with (i.e., equal to) the constant radius of curvature B of convex arc 214.

As noted above, it is preferable that, in addition to the flexion, extension, and lateral bending motions described above, the adjacent vertebral bones be permitted by the artificial disc implant 100 to axially rotate relative to one another (e.g., about the longitudinal axis of the spinal column), through a range of angles without moving in opposite (or otherwise directed away from one another) directions (e.g., along the longitudinal axis) within that range. Preferably, the articulation surfaces 204, 304 are accordingly configured and sized to permit such movement. Referring again to Figures 1-5, a preferred configuration is shown as an example, where the constant radius of curvature A of concave arc 212 is larger than the constant radius of curvature C of convex arc 312, and the constant radius of curvature D of concave arc 314 is larger than the constant radius of curvature B of convex arc 214. It is

understood from the described geometry and positioning of the upper 200 and lower 300 elements that, because of the space, afforded by the differing radii, at the edges of the articulation surfaces 204, 304, the upper 200 and lower 300 elements are able to axially rotate relative to one another (e.g., about the longitudinal axis) through a range of angles without causing the vertebral body contact surfaces 202, 302 to move in opposite (or otherwise directed away from one another) directions (e.g., along the longitudinal axis). Once the axial rotation exceeds that range, the articulation surfaces 204, 304 interfere with one another as the concave arcs 212, 314 move toward positions in which they would be parallel to one another, and the distance between the vertebral body contact surfaces 202, 302 increases with continued axial rotation as the concave arcs 212, 314 ride up against their oppositely directed slopes. Thus, the articulation surfaces 204, 304 are configurable according to the present invention to permit normal physiologic axial rotational motion of the adjacent vertebral bones about the longitudinal axis of the spinal column through a range of angles without abnormal immediate axially opposite (or otherwise directed away from one another) movement, and to permit such axially opposite (or otherwise directed away from one another) movement when under normal physiologic conditions it should occur, that is, outside that range of angles. While the present invention is not limited to any particular dimensions, a preferred embodiment has the following radii of curvature: A = 0.329 inches, B = 0.340 inches, C = 0.280 inches, and D = 0.401 inches. Such preferable radii of curvature provide the preferred embodiment with a longitudinal axial rotation range of plus or minus 3 degrees (total of 6 degrees) before oppositely directed movement of the articulating surfaces occurs.

It should be noted that in the preferred embodiment, and in other preferable embodiments where the constant radius of curvature A of concave arc 212 is larger than the constant radius of curvature C of convex arc 312, and the constant radius of curvature D of concave arc 314 is larger than the constant radius of curvature B of convex arc 214, the articulation surfaces 204, 304 maintain point-to-point contact over a range of normal physiologic articulating movement between the adjacent vertebral bones. This is illustrated in Figures 4, 5, 20, and 21. More particularly, it is understood from the described geometry and positioning of the upper 200 and lower 300 elements that through flexion, extension, lateral bending, and axial rotation, the articulation surfaces 204, 304 are in point-to-point contact with one another as they

are in Figures 4 and 5. Figures 20 and 21 are provided to show the implant 100 in extension and lateral bending, respectively, to further illustrate this preferable feature.

It should further be noted that in addition to the radii of curvature dimensions of the articulation surfaces 204, 304 being relevant to a configuration and sizing of the articulation surfaces 204, 304 permitting normal physiologic flexion, extension, lateral bending, and axial rotation movements of the adjacent vertebral bones, the surface area dimensions are also relevant, particularly in relation to the selected radii of curvature. More particularly, in order to provide a range of relative angulation that is within the normal physiologic range of the cervical spine, not only must the selected radii of curvature be suitable as described above, but also and accordingly the surface area of the saddle surfaces should be of a dimension that, given the selected radii of curvature, prevents the edges of the saddle surfaces (particularly the edges of the concave arcs (e.g., 212 and e.g., 314)) from hitting any surrounding anatomic structures, or other portions of the opposing element (200 or 300), before the limit of the normal physiologic range of the attempted articulation is reached. As shown, one or both of the inwardly facing surfaces of the upper 200 and lower 300 elements can be tapered inwardly before presenting its articulation surface (204 or 304), to ensure a suitable surface area dimension to prevent such interference. While the present invention is not limited to any particular surface area dimensions, the illustrated preferred embodiment has a surface area of articulation surface 204 equal to 0.146 square inches, and a surface area of articulation surface 304 equal to 0.153 square inches.

Further preferably, the articulation surfaces 204, 304 are formed of cobalt-chrome that is polished to provide a smooth bearing surface. It should be understood that the articulation surfaces 204, 304, while preferably formed of cobalt-chrome, can be additionally or alternatively formed of other metals, such as, for example, stainless steel and/or titanium, or of non-metals, such as, for example, polyethylene and/or ceramic materials (e.g., alumina and zirconia), or of any other suitable material without departing from the scope of the present invention.

It should be noted that while the present invention is illustrated and described as an artificial disc implant for use in the cervical spine, the artificial disc implant of the present invention can be adapted for use in any other portion of the spine without departing from the scope of the present invention.

While the particular prostheses for the cervical intervertebral joint of the spine as herein shown and disclosed in detail are each fully capable of obtaining the objects and providing the advantages previously stated, it shall be understood that these variations are merely illustrative of the presently preferred embodiments of the invention and that no limitations to the scope of the present invention are intended to be inferred from the details of the construction or design herein shown.

CLAIMS

1. An articulating joint implant for use in a spinal column, comprising:
a first element having an upper surface for seating against a lower endplate surface of a superior vertebral body and a lower articulating surface, which lower articulating surface includes a saddle surface that is defined by a concave arc having a substantially constant radius of curvature A about a first axis substantially perpendicular to an anterior-posterior plane of the spinal column, and a convex arc having a substantially constant radius of curvature B about a first axis substantially perpendicular to a lateral plane of the spinal column; and
a second element having a lower surface for seating against an upper endplate surface of an inferior vertebral body and an upper articulation surface, which upper articulation surface includes a saddle surface that is defined by a convex arc having a substantially constant radius of curvature C about a second axis substantially perpendicular to the anterior-posterior plane of the spinal column and a concave arc having a substantially constant radius of curvature D about a second axis substantially perpendicular to the lateral plane of the spinal column;
wherein the saddle surface of the first element and the saddle surface of the second element are nestable with one another and articulatable against one another in flexion/extension in an anterior-posterior plane of the spinal column and in lateral bending in a lateral plane of the spinal column, respectively, without their vertebral body contact surfaces substantially moving in directions directed away from one another along a longitudinal axis of the spinal column.
2. The articulating joint implant set forth in claim 1, wherein the first element further includes an anterior flange including at least one through hole for receiving a bone screw.
3. The articulating joint implant set forth in claim 1, wherein the second element further includes an anterior flange including at least one through hole for receiving a bone screw.

4. The articulating joint implant set forth in claim 1, wherein the first and second elements each further include an anterior flange including at least one through hole for receiving a bone screw.

5. The articulating joint implant set forth in claim 4, wherein the anterior flange of one of the first and second elements includes at least two through holes for receiving bone screws.

6. The articulating joint implant set forth in claim 1, wherein the radius of curvature A is not equal to the radius of curvature C.

7. The articulating joint implant set forth in claim 6, wherein the radius of curvature B is not equal to the radius of curvature D.

8. The articulating joint implant set forth in claim 1, wherein the radius of curvature B is not equal to the radius of curvature D.

9. The articulating joint implant as set forth in 1, wherein at least one of: (i) the first and second axes perpendicular to the anterior-posterior plane of the spinal column are substantially coaxial; and (ii) the first and second axes perpendicular to the lateral plane of the spinal column are substantially coaxial.

10. An articulating joint implant for use in a cervical spine, comprising first and second elements having opposing articulation surfaces together defining at least one center of rotation disposed above the articulation surfaces in a first plane and at least one center of rotation disposed below the articulation surfaces in a second plane perpendicular to the first plane, wherein the articulation surfaces remain at substantially constant relative distraction positions through said articulations and through a range of angles of relative rotation about a third axis perpendicular to both the first and second axes.

11. The articulating joint implant as set forth in claim 10, wherein the first and second elements each further include a flange, and each flange has at least one hole extending therethrough for use in securing to adjacent vertebral bones.

12. The articulating joint implant as set forth in claim 10, wherein at least one of the first and second elements further includes a curvate surface opposite its articulation surface for interfacing with a curvate endplate of a vertebral bone against which it is disposed.

13. The articulating joint implant as set forth in claim 10, wherein at least one of the first and second elements further includes at least one spike formed in a surface opposite its articulation surface.

14. A prosthesis for replacing a joint between two vertebral bones, comprising first and second members having respective substantially constant radii saddle shaped articulation surfaces configured and sized to articulate against one another to enable the vertebral bones to articulate in flexion, extension, and lateral bending, and to axially rotate relative to one another through a range of angles without substantially moving in directions directed away from one another.

15. The prosthesis of claim 14, wherein the articulation surfaces are similarly non-congruent in shape and maintain substantial point-to-point contact over a range of normal articulating movement between the vertebral bones.

16. A method for replacing at least a portion of an intervertebral disc in a spinal column, comprising:

removing the portion of the intervertebral disc from the spinal column; and
inserting an apparatus for replacing the portion of the intervertebral disc,

wherein the apparatus for replacing the portion of the intervertebral disc is operable to permit respective vertebral bones of the spinal column between which the apparatus is positioned to articulate in flexion and extension in an anterior-posterior plane of the spinal column, lateral bending in a lateral plane of the spinal column, and axial rotation through a range of angles without permitting the vertebral bones to substantially move in directions directed away from one another along a longitudinal axis of the spinal column.

17. The method of claim 16, wherein the apparatus for replacing the portion of the intervertebral disc is further operable to cause the vertebral bones to displace from one another at axial rotations outside the range of angles.

18. The method of claim 16, wherein:

the apparatus includes a first member having a first vertebral contact surface for engagement with an endplate of a first of the vertebral bones in the spinal column, and a first articulation surface;

the apparatus includes a second member having a second vertebral contact surface for engagement with an endplate of a second of the vertebral bones in the spinal column, and a second articulation surface; and

the first and second articulation surfaces are operable to engage one another to permit flexion and extension in the anterior-posterior plane of the spinal column, lateral bending in the lateral plane of the spinal column, and axial rotation.

19. The method of claim 18, wherein the first member includes an anterior flange including at least one through hole, and the method further comprises inserting at least one bone screw through the at least one through hole to fasten the first member to the first vertebral bone.

20. The method of claim 18, wherein the anterior flange of the first member includes at least two through holes, and the method further comprises inserting a bone screw through each of the through holes to fasten the first member to the first vertebral bone.

21. The method of claim 18, wherein the second member includes an anterior flange including at least one through hole, and the method further comprises inserting at least one bone screw through the at least one through hole to fasten the second member to the second vertebral bone.

22. The method of claim 18, wherein at least one of the first and second members further includes a curvate surface formed on its vertebral contact surface, and the method further comprises positioning the curvate surface to interface with a

curvate portion of the endplate of the vertebral bone against which the vertebral contact surface is disposed.

23. The method of claim 18, wherein at least one of the first and second members further includes at least one spike formed on its vertebral contact surface, and the method further comprises urging the spike into the endplate of the vertebral bone against which the vertebral contact surface is disposed.

24. The method of claim 18, wherein the articulation surfaces are non-congruent in shape and maintain substantial point-to-point contact over a range of articulating movement between the vertebral bones.

25. The method of claim 18, wherein:

the first articulation surface is defined by a concave arc, generally of radius A about a first axis substantially perpendicular to the anterior-posterior plane of the spinal column, and a convex arc, generally of radius B about a first axis substantially perpendicular to the lateral plane of the spinal column; and

the second articulation surface is defined by a convex arc, generally of radius C about a second axis substantially perpendicular to the anterior-posterior plane of the spinal column, and a concave arc, generally of radius D about a second axis substantially perpendicular to the lateral plane of the spinal column.

26. The method of claim 25, wherein at least one of: (i) the first and second axes perpendicular to the anterior-posterior plane of the spinal column are substantially coaxial; and (ii) the first and second axes perpendicular to the lateral plane of the spinal column are substantially coaxial.

27. The method of claim 25, wherein at least one of: (i) the first and second axes perpendicular to the anterior-posterior plane of the spinal column lie in a plane that is substantially perpendicular to the anterior-posterior plane; and (ii) the first and second axes perpendicular to the lateral plane of the spinal column lie in a plane that is substantially perpendicular to the lateral plane.

28. The method of claim 18, wherein the first and second articulation surfaces are saddle shaped such that they are operable to engage when the first and second members are disposed in the intervertebral disc space to articulate in at least one of flexion, extension, lateral bending, and axial rotation.

29. The method of claim 16, wherein the range of angles is about plus/minus three degrees from a resting position.

30. The method of claim 16, wherein the apparatus is operable to permit the vertebral bones to displace away from one another at axial rotations outside the range of angles.

31. A method for replacing at least a portion of an intervertebral disc in a spinal column, comprising:

removing the portion of the intervertebral disc from the spinal column; and

inserting an apparatus for replacing the portion of the intervertebral disc,

wherein:

the apparatus for replacing the portion of the intervertebral disc includes: (i) a first member having a first vertebral contact surface for engagement with an endplate of a first vertebral bone in the spinal column, and having a first saddle shaped articulation surface, and (ii) a second member having a second vertebral contact surface for engagement with an endplate of a second vertebral bone in the spinal column, and having a second saddle shaped articulation surface,

an intervertebral disc space is defined substantially between the first and second endplates of the first and second vertebral bones, and

the first and second articulation surfaces are sized and shaped to engage one another when the first and second members are disposed in the intervertebral disc space to enable the first and second vertebral bones to articulate in at least one of flexion, extension and lateral bending.

32. The method of claim 31, wherein:

the first articulation surface is defined by a concave arc, generally of radius A about a first axis substantially perpendicular to the anterior-posterior plane of the

spinal column, and a convex arc, generally of radius B about a first axis substantially perpendicular to the lateral plane of the spinal column; and

the second articulation surface is defined by a convex arc, generally of radius C about a second axis substantially perpendicular to the anterior-posterior plane of the spinal column, and a concave arc, generally of radius D about a second axis substantially perpendicular to the lateral plane of the spinal column.

33. The method of claim 32, wherein the radius A of the concave arc is greater than the radius C of the convex arc in order to permit at least some axial rotation of the first and second vertebral bones through a range of angles without permitting the vertebral bones to substantially move in directions directed away from one another along a longitudinal axis of the spinal column.

34. The method of claim 32, wherein the radius D of the concave arc is greater than the radius B of the convex arc in order to permit at least some axial rotation of the first and second vertebral bones through a range of angles without permitting the vertebral bones to substantially move in directions directed away from one another along a longitudinal axis of the spinal column.

35. An apparatus for replacing at least a portion of an intervertebral disc in a spinal column, comprising:

a first member having a first vertebral contact surface for engagement with an endplate of a first vertebral bone in the spinal column, and having a first saddle shaped articulation surface; and

a second member having a second vertebral contact surface for engagement with an endplate of a second vertebral bone in the spinal column, and having a second saddle shaped articulation surface, wherein:

an intervertebral disc space is defined substantially between the first and second endplates of the first and second vertebral bones, and

the first and second articulation surfaces are sized and shaped to engage one another when the first and second members are disposed in the intervertebral disc space to enable the first and second vertebral bones to articulate in at least one of flexion, extension and lateral bending.

36. The apparatus of claim 35, wherein the first and second articulation surfaces are sized and shaped to define at least one of: (i) a first center of rotation for at least one of flexion and extension that is located outside the intervertebral disc space, and (ii) a second center of rotation for lateral bending that is located outside the intervertebral disc space.

37. The apparatus of claim 36, wherein the first center of rotation is located outside the intervertebral disc space in one direction and the second center of rotation is located outside the intervertebral disc space in an opposite direction.

38. The apparatus of claim 35, wherein the first and second articulation surfaces are formed from one or more metals or metal alloys to achieve metal-to-metal engagement.

39. The apparatus of claim 38, wherein the one or more metals or metal alloys include at least one of cobalt, chromium, stainless steel, and titanium.

40. The apparatus of claim 35, wherein at least one of the first and second articulation surfaces are formed from one or more non-metals.

41. The apparatus of claim 40, wherein the one or more non-metals are taken from the group consisting of polymers and ceramic materials.

42. An apparatus for replacing at least a portion of an intervertebral disc of a spinal column, comprising:

a first member having a first vertebral contact surface for engagement with an endplate of a first vertebral bone, and having a first saddle shaped articulation surface; and

a second member having a second vertebral contact surface for engagement with an endplate of a second vertebral bone, and having a second saddle shaped articulation surface, wherein:

an intervertebral disc space is defined substantially between the first and second endplates of the first and second vertebral bones, and

the first and second articulation surfaces are sized and shaped to engage one another when the first and second members are disposed in the intervertebral disc space to enable the first and second vertebral bones to at least axially rotate relative to one another through a range of angles.

43. The apparatus of claim 42, wherein the first and second articulation surfaces are sized and shaped to achieve substantial point-to-point contact relative to one another when in at least some positions of flexion, extension, lateral bending, and/or axial rotation.

44. The apparatus of claim 42, wherein:

the first saddle shaped articulation surface is defined by a concave arc, generally of radius A about a first axis substantially perpendicular to an anterior-posterior plane of the spinal column, and a convex arc, generally of radius B about a first axis substantially perpendicular to a lateral plane of the spinal column;

the second saddle shaped articulation surface is defined by a convex arc, generally of radius C about a second axis substantially perpendicular to the anterior-posterior plane of the spinal column, and a concave arc, generally of radius D about a second axis substantially perpendicular to the lateral plane of the spinal column; and

the radius A of the concave arc is greater than the radius C of the convex arc in order to permit axial rotation of the first and second articulation surfaces relative to one another.

45. The apparatus of claim 44, wherein the radius D of the concave arc is greater than the radius B of the convex arc in order to permit axial rotation of the first and second articulation surfaces relative to one another.

46. An apparatus for replacing at least a portion of an intervertebral disc of a spinal column, comprising:

a first member having a first vertebral contact surface for engagement with an endplate of a first vertebral bone, and having a first saddle shaped articulation surface; and

a second member having a second vertebral contact surface for engagement with an endplate of a second vertebral bone, and having a second saddle shaped articulation surface, wherein:

an intervertebral disc space is defined substantially between the first and second endplates of the first and second vertebral bones, and

the first and second articulation surfaces are sized and shaped to engage one another when the first and second members are disposed in the intervertebral disc space to enable the first and second vertebral bones to axially rotate relative to one another through a range of angles without substantially displacing the first and second vertebral bones away from one another.

47. The apparatus of claim 46, wherein the range of angles is about plus/minus three degrees from a resting position.

48. The apparatus of claim 46, wherein the first and second articulation surfaces are sized and shaped such that the first and second vertebral bones are displaced away from one another at axial rotations outside the range of angles.

49. The apparatus of claim 46, wherein:

the first saddle shaped articulation surface is defined by a concave arc, generally of radius A about a first axis substantially perpendicular to an anterior-posterior plane of the spinal column, and a convex arc, generally of radius B about a first axis substantially perpendicular to a lateral plane of the spinal column; and

the second saddle shaped articulation surface is defined by a convex arc, generally of radius C about a second axis substantially perpendicular to the anterior-posterior plane of the spinal column, and a concave arc, generally of radius D about a second axis substantially perpendicular to the lateral plane of the spinal column.

50. The apparatus of claim 49, wherein the radius A of the concave arc is greater than the radius C of the convex arc.

51. The apparatus of claim 49, wherein the radius D of the concave arc is greater than the radius B of the convex arc.

52. The apparatus of claim 49, wherein the radius A of the concave arc is about 0.329 inches, the radius B of the convex arc is about 0.340 inches, the radius C of the convex arc is about 0.280 inches, and the radius D of the concave arc is about 0.401 inches.

53. An apparatus for replacing at least a portion of an intervertebral disc in a spinal column, comprising:

a first member having a first vertebral contact surface for engagement with an endplate of a first vertebral bone in the spinal column, and having a first articulation surface that is defined at least by a concave arc having a radius of curvature A about a first axis substantially perpendicular to an anterior-posterior plane of the spinal column, and by a convex arc having a radius of curvature B about a first axis substantially perpendicular to a lateral plane of the spinal column; and

a second member having a second vertebral contact surface for engagement with an endplate of a second vertebral bone in the spinal column, and having a second articulation surface that is defined at least by a convex arc having a radius of curvature C about a second axis substantially perpendicular to the anterior-posterior plane of the spinal column, and by a concave arc having a radius of curvature D about a second axis substantially perpendicular to the lateral plane of the spinal column, wherein:

an intervertebral disc space is defined substantially between the first and second endplates of the first and second vertebral bones, and

the radii of curvature of the first and second articulation surfaces are sized such that the first and second articulation surfaces engage one another when the first and second members are disposed in the intervertebral disc space to enable the first and second vertebral bones to articulate in at least one of flexion, extension and lateral bending.

54. The apparatus of claim 53, wherein at least one of: (i) the first and second axes perpendicular to the anterior-posterior plane of the spinal column are substantially coaxial; and (ii) the first and second axes perpendicular to the lateral plane of the spinal column are substantially coaxial.

55. The apparatus of claim 53, wherein at least one of: (i) the first and second axes perpendicular to the anterior-posterior plane of the spinal column lie in a plane that is substantially perpendicular to the anterior-posterior plane; and (ii) the first and second axes perpendicular to the lateral plane of the spinal column lie in a plane that is substantially perpendicular to the lateral plane.

56. The apparatus of claim 53, wherein the first and second articulation surfaces are sized and shaped to define at least one of: (i) a first center of rotation for at least one of flexion and extension that is located outside the intervertebral disc space, and (ii) a second center of rotation for lateral bending that is located outside the intervertebral disc space.

57. The apparatus of claim 56, wherein the first center of rotation is located outside the intervertebral disc space in one direction and the second center of rotation is located outside the vertebral disc space in a substantially opposite direction.

58. The apparatus of claim 53, wherein the first and second articulation surfaces are sized and shaped to engage one another when the first and second members are disposed in the intervertebral disc space to enable the first and second vertebral bones to at least axially rotate relative to one another through a range of angles.

59. The apparatus of claim 53, wherein the first and second articulation surfaces are sized and shaped to engage one another when the first and second members are disposed in the intervertebral disc space to enable the first and second vertebral bones to axially rotate relative to one another through a range of angles without substantially displacing the first and second vertebral bones away from one another.

60. The apparatus of claim 59, wherein the first and second articulation surfaces are sized and shaped to achieve substantial point-to-point contact relative to one another when in at least some positions of flexion, extension, lateral bending, and/or axial rotation.

61. The apparatus of claim 59, wherein the range of angles is about plus/minus three degrees from a resting position.

62. The apparatus of claim 59, wherein the first and second articulation surfaces are sized and shaped such that the first and second vertebral bones are displaced away from one another at axial rotations outside the range of angles.

63. The apparatus of claim 53, wherein the radius A of the concave arc is greater than the radius C of the convex arc in order to permit axial rotation of the first and second articulation surfaces relative to one another.

64. The apparatus of claim 53, wherein the radius D of the concave arc is greater than the radius B of the convex arc in order to permit axial rotation of the first and second articulation surfaces relative to one another.

65. The apparatus of claim 53, wherein the radius A of the concave arc is about 0.329 inches, the radius B of the convex arc is about 0.340 inches, the radius C of the convex arc is about 0.280 inches, and the radius D of the concave arc is about 0.401 inches.

66. The apparatus of claim 53, wherein the first member further includes an anterior flange including at least one through hole for receiving a bone screw.

67. The apparatus of claim 53, wherein the second member further includes an anterior flange including at least one through hole for receiving a bone screw.

68. The apparatus of claim 53, wherein the first and second members each further include an anterior flange including at least one through hole for receiving a bone screw.

69. The apparatus of claim 68, wherein the anterior flange of one of the first and second members includes at least two through holes for receiving bone screws.

70. An apparatus for replacing at least a portion of an intervertebral disc in a spinal column, comprising:

a first member having a first vertebral contact surface for engagement with an endplate of a first vertebral bone in the spinal column, and having a first articulation surface that is defined by a plurality of concave arcs each having a respective radius of curvature about a corresponding axis substantially perpendicular to an anterior-posterior plane of the spinal column, and a plurality of convex arcs each having a respective radius of curvature about a corresponding axis substantially perpendicular to a lateral plane of the spinal column; and

a second member having a second vertebral contact surface for engagement with an endplate of a second vertebral bone in the spinal column, and having a second articulation surface that is defined by a plurality of convex arcs each having a radius of curvature about a corresponding axis substantially perpendicular to the anterior-posterior plane of the spinal column, and a plurality of concave arcs each having a radius of curvature about a corresponding axis substantially perpendicular to the lateral plane of the spinal column, wherein:

an intervertebral disc space is defined substantially between the first and second endplates of the first and second vertebral bones, and

the radii of curvature of the first and second articulation surfaces are sized such that the first and second articulation surfaces engage one another when the first and second members are disposed in the intervertebral disc space to enable the first and second vertebral bones to articulate in at least one of flexion, extension and lateral bending.

71. The apparatus of claim 70, wherein at least one of: (i) the axes perpendicular to the anterior-posterior plane of the spinal column are substantially coaxial; and (ii) the axes perpendicular to the lateral plane of the spinal column are substantially coaxial.

72. The apparatus of claim 70, wherein at least one of: (i) the axes perpendicular to the anterior-posterior plane of the spinal column lie in a plane that is substantially perpendicular to the anterior-posterior plane; and (ii) the axes perpendicular to the lateral plane of the spinal column lie in a plane that is substantially perpendicular to the lateral plane.

73. The apparatus of claim 70, wherein:

at least one of the concave arcs of the first articulation surface has a radius of curvature A about a first axis substantially perpendicular to the anterior-posterior plane of the spinal column, and at least one of the convex arcs of the first articulation surface has a radius of curvature B about a first axis substantially perpendicular to the lateral plane of the spinal column; and

at least one of the convex arcs of the second articulation surface has a radius of curvature C about a second axis substantially perpendicular to the anterior-posterior plane of the spinal column, and at least one of the concave arcs of the second articulation surface has a radius of curvature D about a second axis substantially perpendicular to the lateral plane of the spinal column.

74. The apparatus of claim 70, wherein:

the concave arcs of the first articulation surface are of substantially the same radius of curvature, each generally about a corresponding axis substantially perpendicular to the anterior-posterior plane of the spinal column;

the convex arcs of the first articulation surface are of substantially the same radius of curvature, each generally about a corresponding axis substantially perpendicular to the lateral plane of the spinal column;

the convex arcs of the second articulation surface are of substantially the same radius of curvature, each generally about a corresponding axis substantially perpendicular to the anterior-posterior plane of the spinal column; and

the concave arcs of the second articulation surface are of substantially the same radius of curvature, each generally about a corresponding axis substantially perpendicular to the lateral plane of the spinal column.

75. The apparatus of claim 70, wherein:

the concave arcs of the first articulation surface are of differing radii of curvature, each generally about a corresponding axis substantially perpendicular to the anterior-posterior plane of the spinal column; and

the convex arcs of the second articulation surface are of differing radii of curvature, each generally about a corresponding axis substantially perpendicular to the anterior-posterior plane of the spinal column.

76. The apparatus of claim 75, wherein the convex arcs of the second articulation surface are of differing radii of curvature that correspond with the differing radii of curvature of the concave arcs of the first articulation surface.

77. The apparatus of claim 75, wherein:

the anterior-posterior plane and the lateral plane intersect along a longitudinal axis of the intervertebral disc space when the apparatus is disposed in the intervertebral disc space;

one or more of the radii of the concave arcs of the first articulation surface reduce as distances of origins of the radii from the anterior-posterior plane along the corresponding axes increase; and

one or more of the radii of the convex arcs of the second articulation surface reduce as distances of origins of the radii of the convex arcs of the second articulation surface from the anterior-posterior plane along the corresponding axes increase.

78. The apparatus of claim 77, wherein the one or more of the radii of the convex arcs of the second articulation surface reduce in correspondence with the radii of the concave arcs of the first articulation surface.

79. The apparatus of claim 75, wherein:

the convex arcs of the first articulation surface are of substantially the same radius of curvature, each generally about a corresponding axis substantially perpendicular to the lateral plane of the spinal column; and

the concave arcs of the second articulation surface are of substantially the same radius of curvature, each generally about a corresponding axis substantially perpendicular to the lateral plane of the spinal column.

80. The apparatus of claim 70, wherein:

the convex arcs of the first articulation surface are of differing radii of curvature, each generally about a corresponding axis substantially perpendicular to the lateral plane of the spinal column;

the concave arcs of the second articulation surface are of differing radii of curvature, each of the concave arcs of the second articulation surface being generally about a corresponding axis substantially perpendicular to the lateral plane of the spinal column.

81. The apparatus of claim 80, wherein the concave arcs of the second articulation surface are of differing radii of curvature that correspond with the differing radii of curvature of the convex arcs of the first articulation surface.

82. The apparatus of claim 80, wherein:

the anterior-posterior plane and the lateral plane intersect along a longitudinal axis of the intervertebral disc space when the apparatus is disposed in the intervertebral disc space;

one or more of the radii of the convex arcs of the first articulation surface reduce as distances of origins of the radii from the lateral plane along the corresponding axes increase; and

one or more of the radii of the concave arcs of the second articulation surface reduce as distances of origins of the radii of the convex arcs of the second articulation surface from the lateral plane along the corresponding axes increase.

83. The apparatus of claim 82, wherein the one or more of the radii of the concave arcs of the second articulation surface reduce in correspondence with the radii of the convex arcs of the first articulation surface.

84. The apparatus of claim 80, wherein:

the concave arcs of the first articulation surface are of substantially the same radius of curvature, each generally about a corresponding axis substantially perpendicular to the anterior-posterior plane of the spinal column; and

the convex arcs of the second articulation surface are of substantially the same radius of curvature, each generally about a corresponding axis substantially perpendicular to the anterior-posterior plane of the spinal column.

85. The apparatus of claim 70, wherein the first and second articulation surfaces are sized and shaped to engage one another when the first and second members are disposed in the intervertebral disc space to enable the first and second vertebral bones to at least axially rotate relative to one another through a range of angles.

86. The apparatus of claim 70, wherein the first and second articulation surfaces are sized and shaped to engage one another when the first and second members are disposed in the intervertebral disc space to enable the first and second vertebral bones to axially rotate relative to one another through a range of angles without substantially displacing the first and second vertebral bones away from one another.

87. The apparatus of claim 86, wherein the first and second articulation surfaces are sized and shaped to achieve substantial point-to-point contact relative to one another when in at least some positions of flexion, extension, lateral bending, and/or axial rotation.

88. The apparatus of claim 86, wherein the range of angles is about plus/minus three degrees from a resting position.

89. The apparatus of claim 86, wherein the first and second articulation surfaces are sized and shaped such that the first and second vertebral bones are displaced away from one another at axial rotations outside the range of angles.

90. An apparatus for replacing at least a portion of an intervertebral disc in a spinal column, comprising:

a first member having a first vertebral contact surface for engagement with an endplate of a first vertebral bone in the spinal column, and having a first articulation surface; and

a second member having a second vertebral contact surface for engagement with an endplate of a second vertebral bone in the spinal column, and having a second articulation surface, wherein:

an intervertebral disc space is defined substantially between the first and second endplates of the first and second vertebral bones, and

at least one of the first and second articulation surfaces is a saddle shaped surface, and the articulation surfaces are sized and shaped to engage one another when the first and second members are disposed in the intervertebral disc space to enable the first and second vertebral bones to articulate in at least one of flexion, extension, and lateral bending.

91. The apparatus of claim 90, wherein both the first and second articulation surfaces are saddle shaped.

92. The apparatus of claim 90, wherein the first articulation surface is saddle shaped and the second articulation surface is defined by at least one bearing surface for engaging respective portions of the first articulation surface when the first and second members are disposed in the intervertebral disc space to enable the first and second vertebral bones to articulate in at least one of flexion, extension, and lateral bending.

93. The apparatus of claim 90, wherein the at least one saddle shaped articulation surface is defined by at least one bearing surface that in the aggregate cooperates to engage respective portions of the other articulation surface when the first and second members are disposed in the intervertebral disc space to enable the first and second vertebral bones to articulate in at least one of flexion, extension, and lateral bending.

94. The apparatus of claim 93, wherein the at least one bearing surface defines a contiguous saddle shaped articulation surface.

95. The apparatus of claim 90, wherein the at least one saddle shaped articulation surface is one of:

defined at least by a concave arc having a radius of curvature A about a first axis substantially perpendicular to an anterior-posterior plane of the spinal column, and a convex arc having a radius of curvature B about a first axis substantially perpendicular to a lateral plane of the spinal column; and

defined at least by a convex arc having a radius of curvature C about a second axis substantially perpendicular to the anterior-posterior plane of the spinal column, and a concave arc having a radius of curvature D about a second axis substantially perpendicular to the lateral plane of the spinal column.

96. The apparatus of claim 90, wherein the first and second articulation surfaces are sized and shaped to engage one another when the first and second members are disposed in the intervertebral disc space to enable the first and second vertebral bones to at least axially rotate relative to one another through a range of angles.

97. The apparatus of claim 90, wherein the first and second articulation surfaces are sized and shaped to engage one another when the first and second members are disposed in the intervertebral disc space to enable the first and second vertebral bones to axially rotate relative to one another through a range of angles without substantially displacing the first and second vertebral bones away from one another.

98. The apparatus of claim 97, wherein the first and second articulation surfaces are sized and shaped such that the first and second vertebral bones are substantially displaced away from one another at axial rotations outside the range of angles.

99. An apparatus for replacing at least a portion of an intervertebral disc in a spinal column, comprising:

a first member having a first vertebral contact surface for engagement with an endplate of a first vertebral bone in the spinal column, and having a first articulation surface; and

a second member having a second vertebral contact surface for engagement with an endplate of a second vertebral bone in the spinal column, and having a second articulation surface, wherein:

an intervertebral disc space is defined substantially between the first and second endplates of the first and second vertebral bones, and

at least one of the first and second articulation surfaces is defined by at least one bearing surface that in the aggregate cooperates to define a saddle shaped surface, and the first and second articulation surfaces are sized and shaped to engage one another when the first and second members are disposed in the intervertebral disc space to enable the first and second vertebral bones to articulate in at least one of flexion, extension, and lateral bending.

100. The apparatus of claim 99, wherein each of the first and second articulation surfaces include at least one bearing surface that in the aggregate defines a saddle shape.

101. The apparatus of claim 99, wherein the first articulation surface includes at least one bearing surface defining the saddle shape and the second articulation surface is defined by at least one bearing surface for engaging respective portions of the first articulation surface when the first and second members are disposed in the intervertebral disc space to enable the first and second vertebral bones to articulate in at least one of flexion, extension, and lateral bending

102. The apparatus of claim 99, wherein the at least one bearing surface defines a contiguous saddle shaped articulation surface.

103. The apparatus of claim 99, wherein the at least one saddle shaped articulation surface is one of:

defined at least by a concave arc having a radius of curvature A about a first axis substantially perpendicular to an anterior-posterior plane of the spinal column, and by a convex arc having a radius of curvature B about a first axis substantially perpendicular to a lateral plane of the spinal column; and

defined at least by a convex arc having a radius of curvature C about a second axis substantially perpendicular to the anterior-posterior plane of the spinal column,

and by a concave arc having a radius of curvature D about a second axis substantially perpendicular to the lateral plane of the spinal column.

104. The apparatus of claim 99, wherein the first and second articulation surfaces are sized and shaped to engage one another when the first and second members are disposed in the intervertebral disc space to enable the first and second vertebral bones to at least axially rotate relative to one another through a range of angles.

105. The apparatus of claim 99, wherein the first and second articulation surfaces are sized and shaped to engage one another when the first and second members are disposed in the intervertebral disc space to enable the first and second vertebral bones to axially rotate relative to one another through a range of angles without substantially displacing the first and second vertebral bones away from one another.

106. The apparatus of claim 105, wherein the first and second articulation surfaces are sized and shaped such that the first and second vertebral bones are displaced away from one another at axial rotations outside the range of angles.

107. An apparatus for replacing at least a portion of an intervertebral disc in a spinal column, comprising:

a first member having a first vertebral contact surface for engagement with an endplate of a first vertebral bone in the spinal column; and

a second member having a second vertebral contact surface for engagement with an endplate of a second vertebral bone in the spinal column, wherein:

an intervertebral disc space is defined substantially between the first and second endplates of the first and second vertebral bones, and

the first and second members are operable to articulate relative to one another, when disposed in the intervertebral disc space, about at least one of: (i) a first center of rotation for at least one of flexion and extension that is located outside the intervertebral disc space, and (ii) a second center of rotation for lateral bending that is located outside the intervertebral disc space.

108. The apparatus of claim 107, wherein the first center of rotation is located outside the intervertebral disc space in one direction and the second center of rotation is located outside the intervertebral disc space in an opposite direction.

109. The apparatus of claim 107, wherein:
the first member includes a first articulation surface; and
the second member includes a second articulation surface,
wherein the first and second articulation surfaces are sized and shaped to engage one another when the first and second members are disposed in the intervertebral disc space to enable at least one of flexion, extension, and lateral bending.

110. The apparatus of claim 109, wherein:
the first articulation surface is defined by a concave arc, generally of radius A about a first axis substantially perpendicular to an anterior-posterior plane of the spinal column, and a convex arc, generally of radius B about a first axis substantially perpendicular to a lateral plane of the spinal column; and
the second articulation surface is defined by a convex arc, generally of radius C about a second axis substantially perpendicular to the anterior-posterior plane of the spinal column, and a concave arc, generally of radius D about a second axis substantially perpendicular to the lateral plane of the spinal column.

111. The apparatus of claim 110, wherein the first and second articulation surfaces are sized and shaped to engage one another when the first and second members are disposed in the intervertebral disc space to enable the first and second vertebral bones to at least axially rotate relative to one another through a range of angles.

112. The apparatus of claim 111, wherein the radius A of the concave arc is greater than the radius C of the convex arc in order to permit axial rotation of the first and second vertebral bones relative to one another.

113. The apparatus of claim 111, wherein the radius D of the concave arc is greater than the radius B of the convex arc in order to permit axial rotation of the first and second vertebral bones relative to one another.

114. The apparatus of claim 111, wherein the first and second articulation surfaces are sized and shaped to achieve substantial point-to-point contact relative to one another when the spinal column is in at least some positions of flexion, extension, lateral bending, and/or axial rotation.

115. The apparatus of claim 111, wherein the first and second articulation surfaces are sized and shaped to engage one another when the first and second members are disposed in the intervertebral disc space to enable the first and second vertebral bones to axially rotate relative to one another through the range of angles without substantially displacing the first and second vertebral bones away from one another.

116. The apparatus of claim 115, wherein the range of angles is about plus/minus three degrees from a resting position.

117. The apparatus of claim 115, wherein the first and second articulation surfaces are sized and shaped such that the first and second vertebral bones are displaced away from one another at axial rotations outside the range of angles.

118. The apparatus of claim 110, wherein at least one of: (i) the first and second axes perpendicular to the anterior-posterior plane of the spinal column are substantially coaxial; and (ii) the first and second axes perpendicular to the lateral plane of the spinal column are substantially coaxial.

119. The apparatus of claim 110, wherein at least one of: (i) the first and second axes perpendicular to the anterior-posterior plane of the spinal column lie in a plane that is substantially perpendicular to the anterior-posterior plane; and (ii) the first and second axes perpendicular to the lateral plane of the spinal column lie in a plane that is substantially perpendicular to the lateral plane.

120. The apparatus of claim 109, wherein the first and second articulation surfaces are saddle shaped such that they are operable to engage when the first and second members are disposed in the intervertebral disc space to articulate in at least one of flexion, extension, and lateral bending.

121. An apparatus for replacing at least a portion of an intervertebral disc in a spinal column, comprising:

first means for engagement with an endplate of a first vertebral bone in the spinal column; and

second means for engagement with an endplate of a second vertebral bone in the spinal column, wherein:

an intervertebral disc space is defined substantially between the first and second endplates of the first and second vertebral bones, and

the first and second means are operable to articulate relative to one another, when the first and second means are disposed in the intervertebral disc space, about at least one of: (i) a first center of rotation for at least one of flexion and extension that is located outside the intervertebral disc space, and (ii) a second center of rotation for lateral bending that is located outside the intervertebral disc space.

122. An apparatus for replacing at least a portion of an intervertebral disc in a spinal column, comprising:

a first member having a first vertebral contact surface for engagement with an endplate of a first vertebral bone in the spinal column, and having a first articulation means; and

a second member having a second vertebral contact surface for engagement with an endplate of a second vertebral bone in the spinal column, and having a second articulation means, wherein:

an intervertebral disc space is defined substantially between the first and second endplates of the first and second vertebral bones, and

the first and second articulation means are operable to articulate relative to one another, when the first and second members are disposed in the intervertebral disc space, about at least one of: (i) a first center of rotation for at least one of flexion and extension that is located outside the intervertebral disc space, and (ii) a second center of rotation for lateral bending that is located outside the intervertebral disc space.

123. A method for replacing at least a portion of an intervertebral disc in a spinal column, comprising:

removing the portion of the intervertebral disc from the spinal column; and

inserting an apparatus for replacing the portion of the intervertebral disc into an intervertebral disc space defined substantially between adjacent vertebral bones of the spinal column, and positioning the apparatus between the vertebral bones,

wherein the apparatus is operable to permit the adjacent vertebral bones to articulate relative to one another about at least one of: (i) a first center of rotation for at least one of flexion and extension that is located outside the intervertebral disc space, and (ii) a second center of rotation for lateral bending that is located outside the intervertebral disc space.

124. The method of claim 123, wherein the first center of rotation is located outside the intervertebral disc space in one direction and the second center of rotation is located outside the intervertebral disc space in an opposite direction.

125. The method of claim 123, wherein:

the apparatus includes a first member having a first vertebral contact surface for engagement with an endplate of a first of the vertebral bones in the spinal column;

the apparatus includes a second member having a second vertebral contact surface for engagement with an endplate of a second of the vertebral bones in the spinal column; and

the first and second members are operable to articulate with respect to one another to permit flexion and extension in an anterior-posterior plane of the spinal column, and to permit lateral bending in a lateral plane of the spinal column, respectively.

126. The method of claim 125, wherein the first center of rotation is associated with the articulation of the first and second members in flexion and extension in the anterior-posterior plane of the spinal column, and the first center of rotation is located outside the intervertebral disc space in one direction.

127. The method of claim 126, wherein the second center of rotation is associated with the articulation of the first and second members in lateral bending in the lateral plane of the spinal column, and the second center of rotation is located outside the intervertebral disc space in an opposite direction.

128. The method of claim 125, wherein:
the first member includes a first articulation surface;
the second member includes a second articulation surface; and
the first and second articulation surfaces are operable to engage one another to permit flexion and extension in the anterior-posterior plane of the spinal column, and permit lateral bending in the lateral plane of the spinal column, respectively.

129. The method of claim 128, wherein:
the first articulation surface is defined by a concave arc, generally of radius A about a first axis substantially perpendicular to the anterior-posterior plane of the spinal column, and a convex arc, generally of radius B about a first axis substantially perpendicular to the lateral plane of the spinal column; and
the second articulation surface is defined by a convex arc, generally of radius C about a second axis substantially perpendicular to the anterior-posterior plane of the spinal column, and a concave arc, generally of radius D about a second axis substantially perpendicular to the lateral plane of the spinal column.

130. The method of claim 129, wherein at least one of: (i) the first and second axes perpendicular to the anterior-posterior plane of the spinal column are substantially coaxial; and (ii) the first and second axes perpendicular to the lateral plane of the spinal column are substantially coaxial.

131. The method of claim 129, wherein at least one of: (i) the first and second axes perpendicular to the anterior-posterior plane of the spinal column lie in a plane that is substantially perpendicular to the anterior-posterior plane; and (ii) the first and second axes perpendicular to the lateral plane of the spinal column lie in a plane that is substantially perpendicular to the lateral plane.

132. The method of claim 129, wherein the first and second articulation surfaces are saddle shaped such that they are operable to engage when the first and second members are disposed in the intervertebral disc space to articulate in at least one of flexion, extension, and lateral bending.

133. The method of claim 125, wherein the first member includes an anterior flange including at least one through hole, and the method further comprises inserting at least one bone screw through the at least one through hole to fasten the first member to the first vertebral bone.

134. The method of claim 125, wherein the anterior flange of the first member includes at least two through holes, and the method further comprises inserting a bone screw through each of the through holes to fasten the first member to the first vertebral bone.

135. The method of claim 125, wherein the second member includes an anterior flange including at least one through hole, and the method further comprises inserting at least one bone screw through the at least one through hole to fasten the second member to the second vertebral bone.

136. The method of claim 125, wherein at least one of the first and second members further includes a curvate surface formed on its vertebral contact surface, and the method further comprises positioning the curvate surface to interface with a curvate portion of the endplate of the vertebral bone against which the vertebral contact surface is disposed.

137. The method of claim 125, wherein at least one of the first and second members further includes at least one spike formed on its vertebral contact surface, and the method further comprises urging the spike into the endplate of the vertebral bone against which the vertebral contact surface is disposed.

138. The method of claim 123, wherein the apparatus is operable to permit the first and second vertebral bones to at least axially rotate relative to one another through a range of angles.

139. The method of claim 138, wherein the apparatus is operable to permit the first and second vertebral bones to axially rotate relative to one another through the range of angles without substantially displacing the first and second vertebral bones away from one another.

140. The method of claim 139, wherein the range of angles is about plus/minus three degrees from a resting position.

141. The method of claim 139, wherein the apparatus is operable to permit the first and second vertebral bones to displace away from one another at axial rotations outside the range of angles.

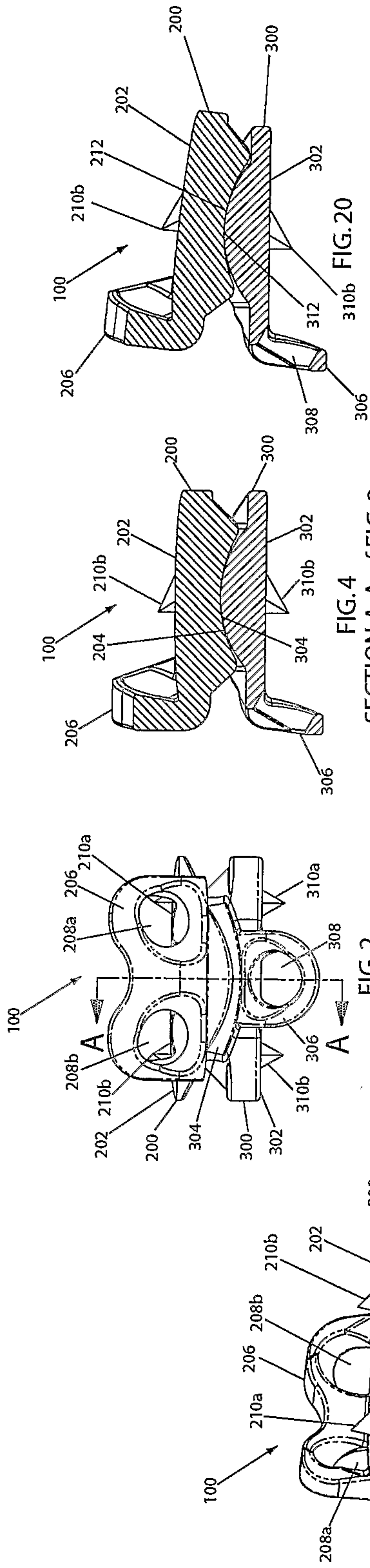

FIG. 1

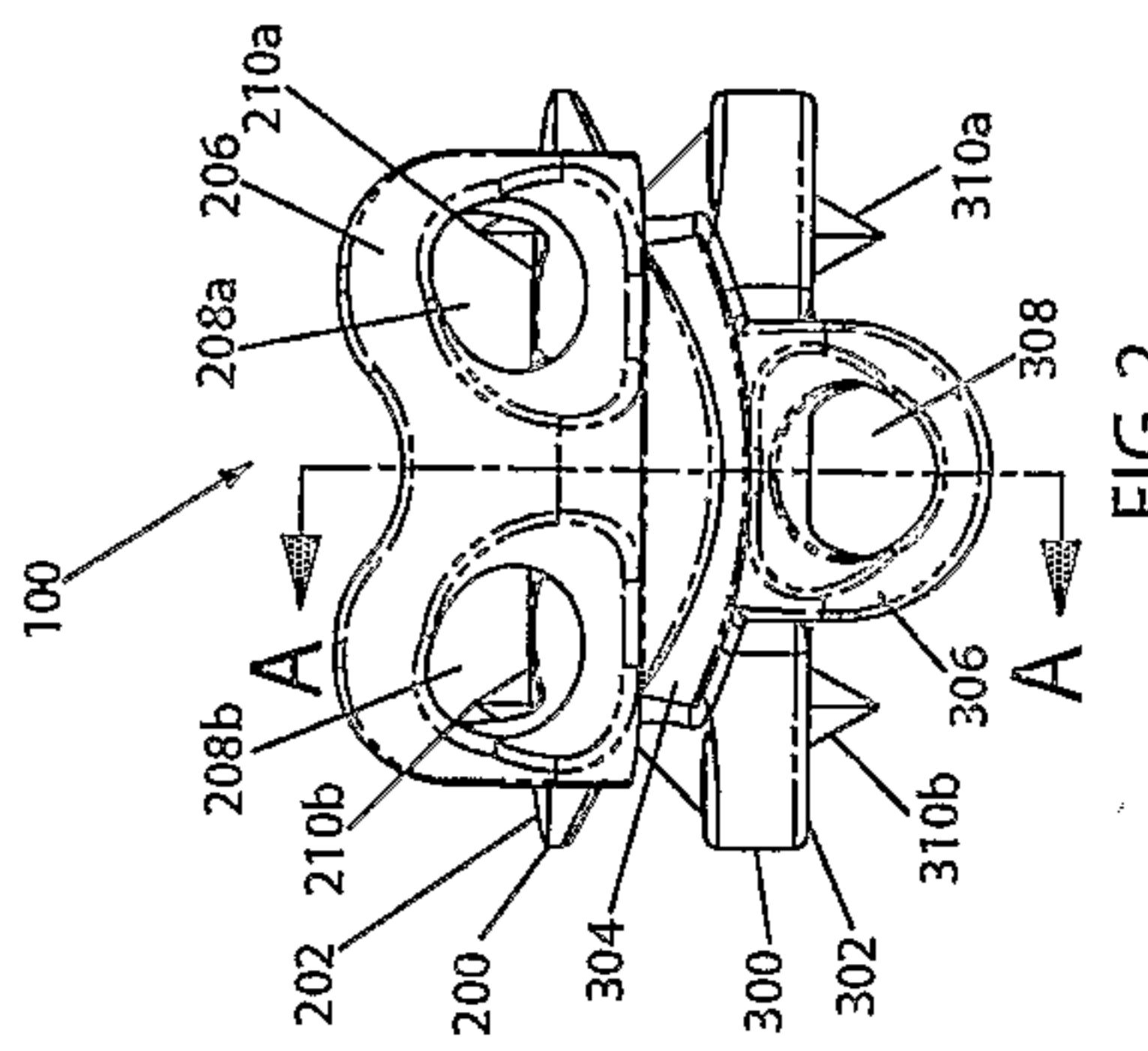

FIG. 2

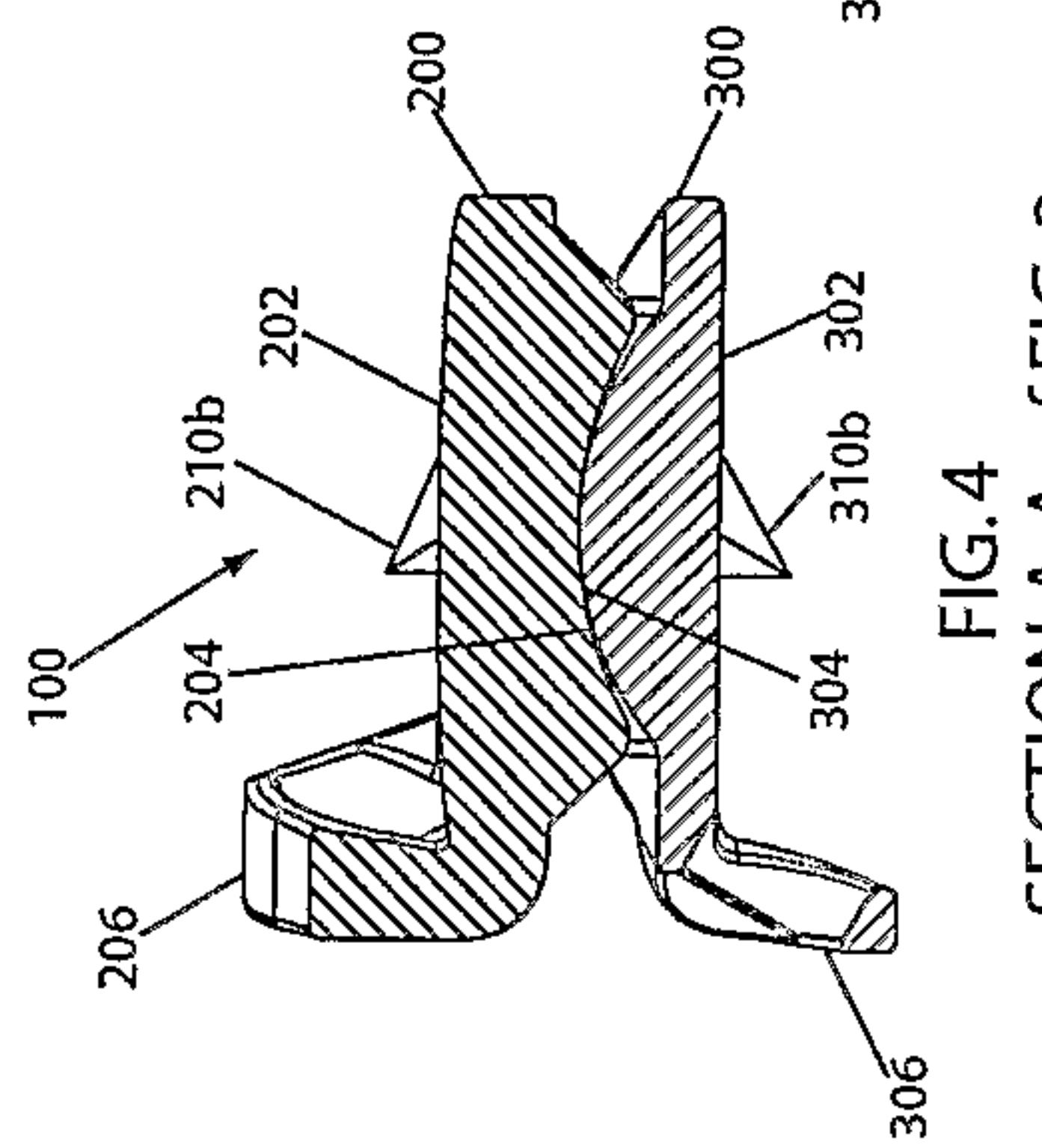

FIG. 3

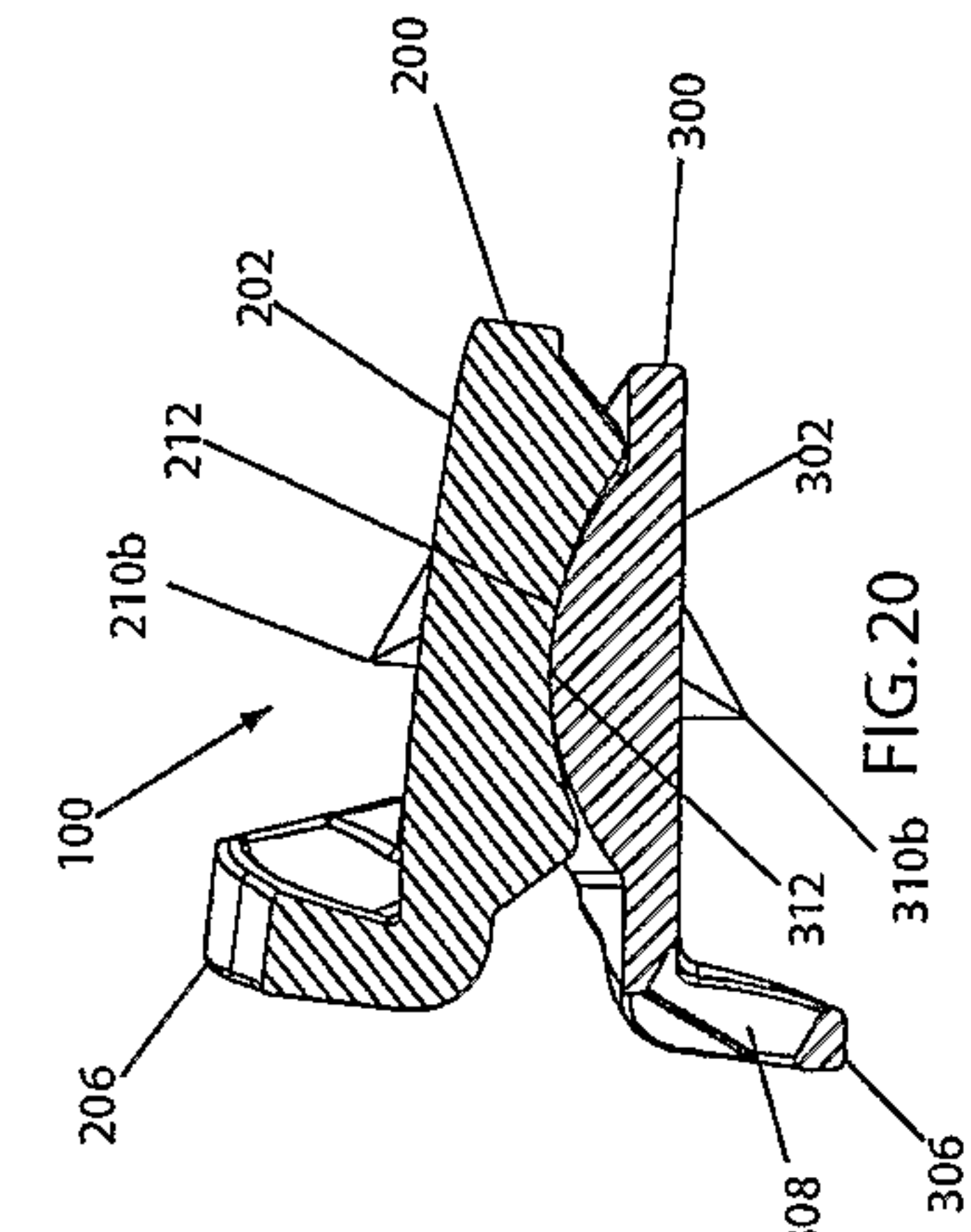

FIG. 4
SECTION A-A of FIG. 2

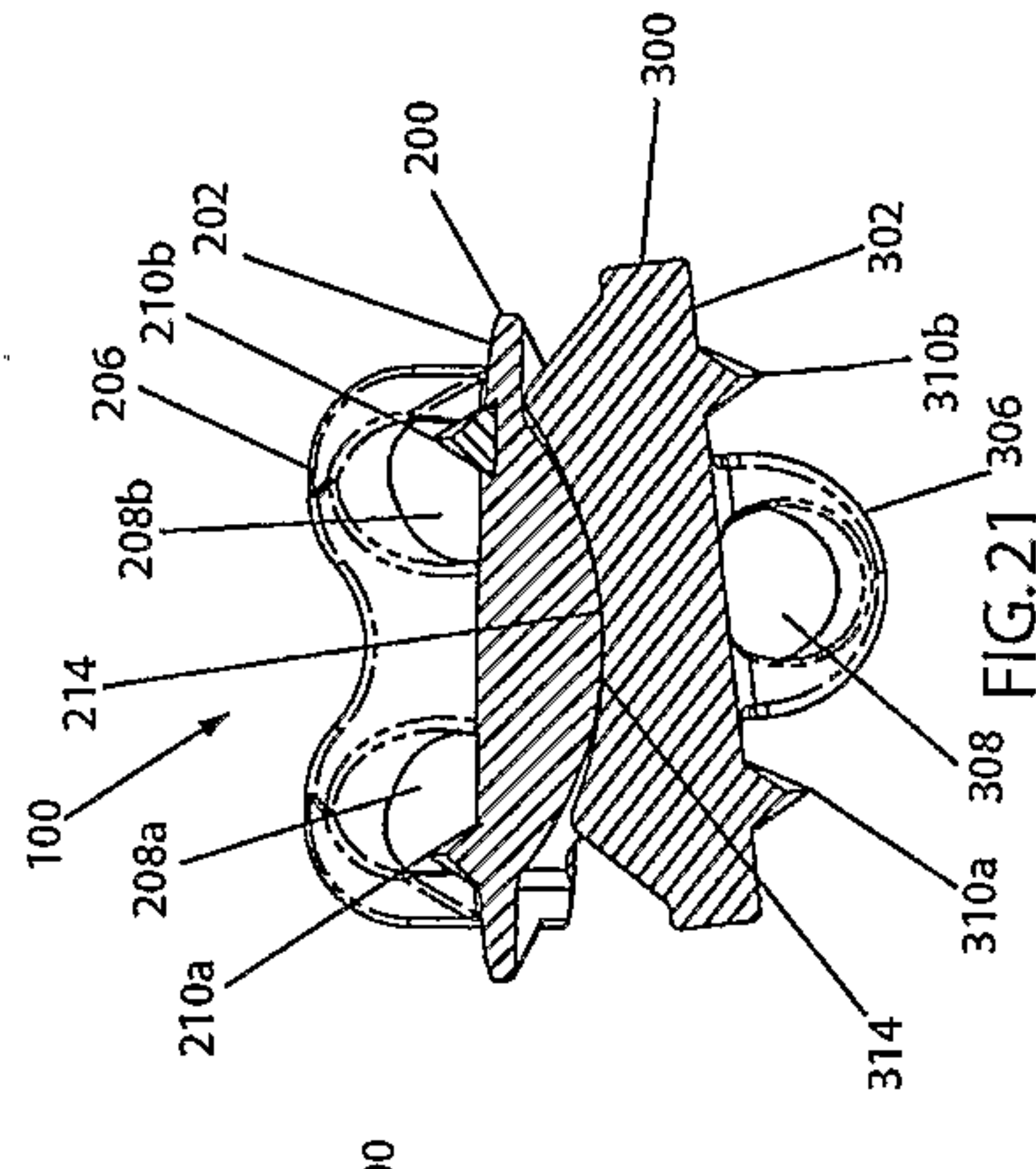

FIG. 5
SECTION B-B of FIG. 3

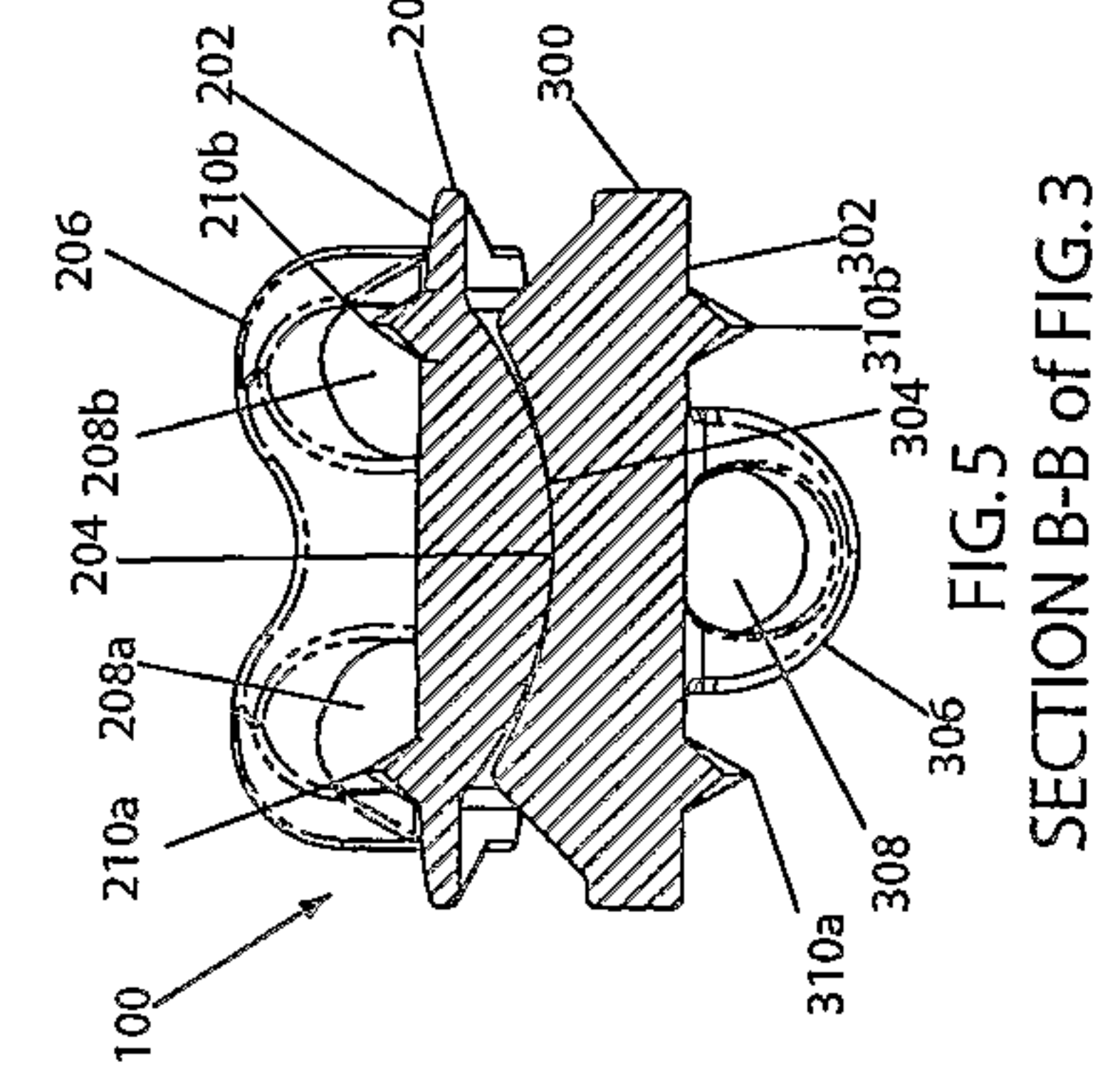

FIG. 21

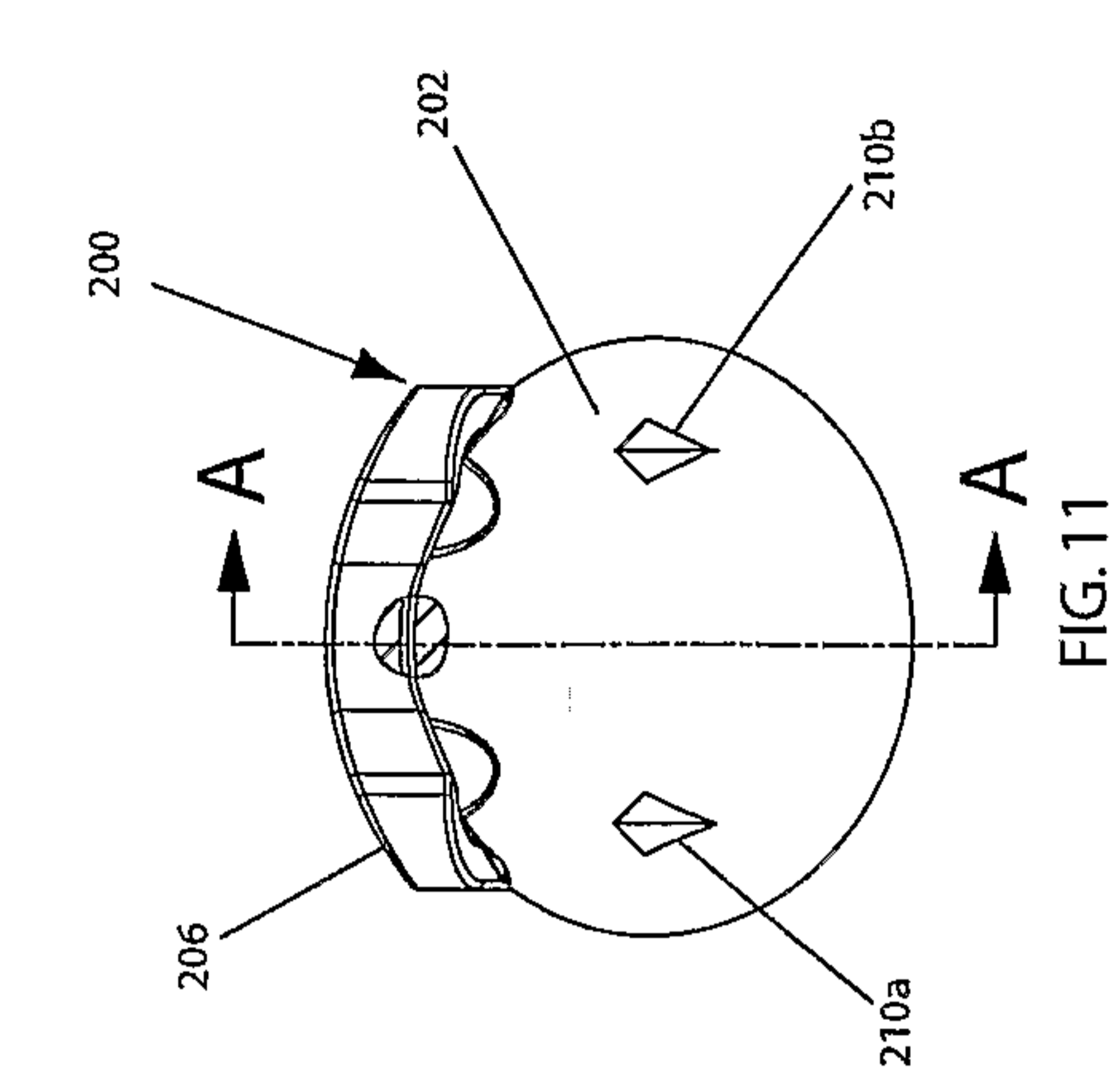

FIG. 11

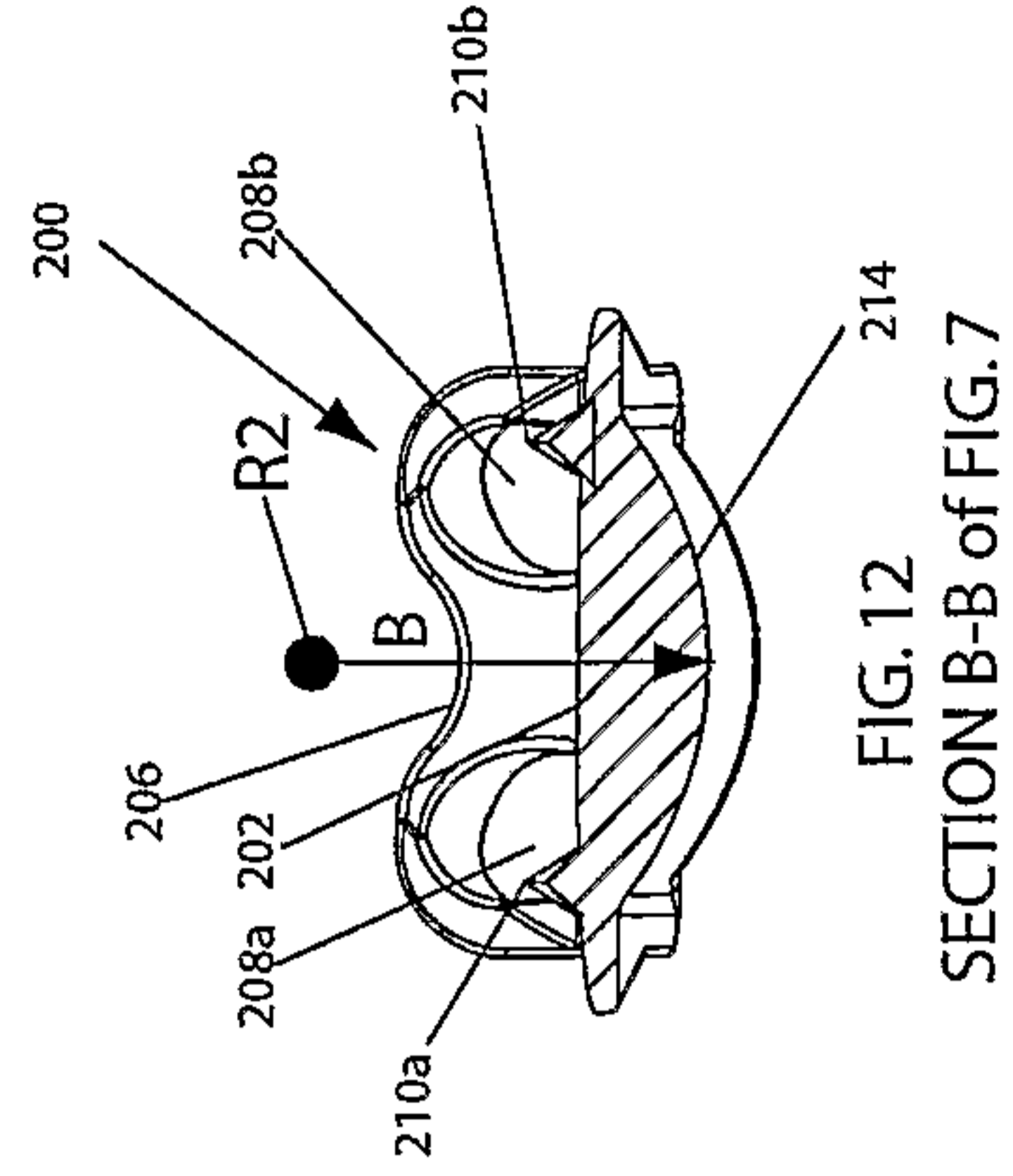

FIG. 12
SECTION B-B of FIG. 7

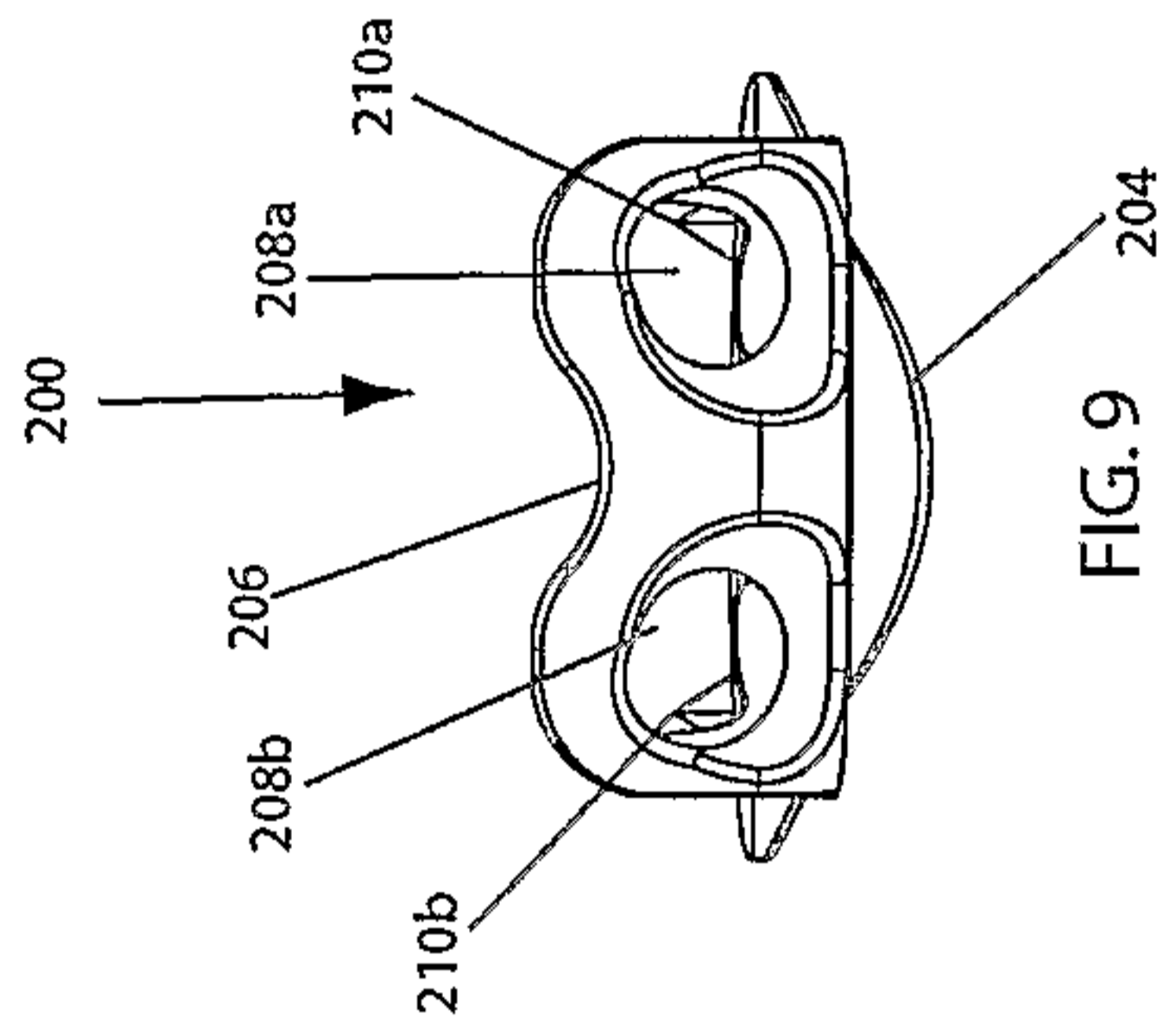

FIG. 9

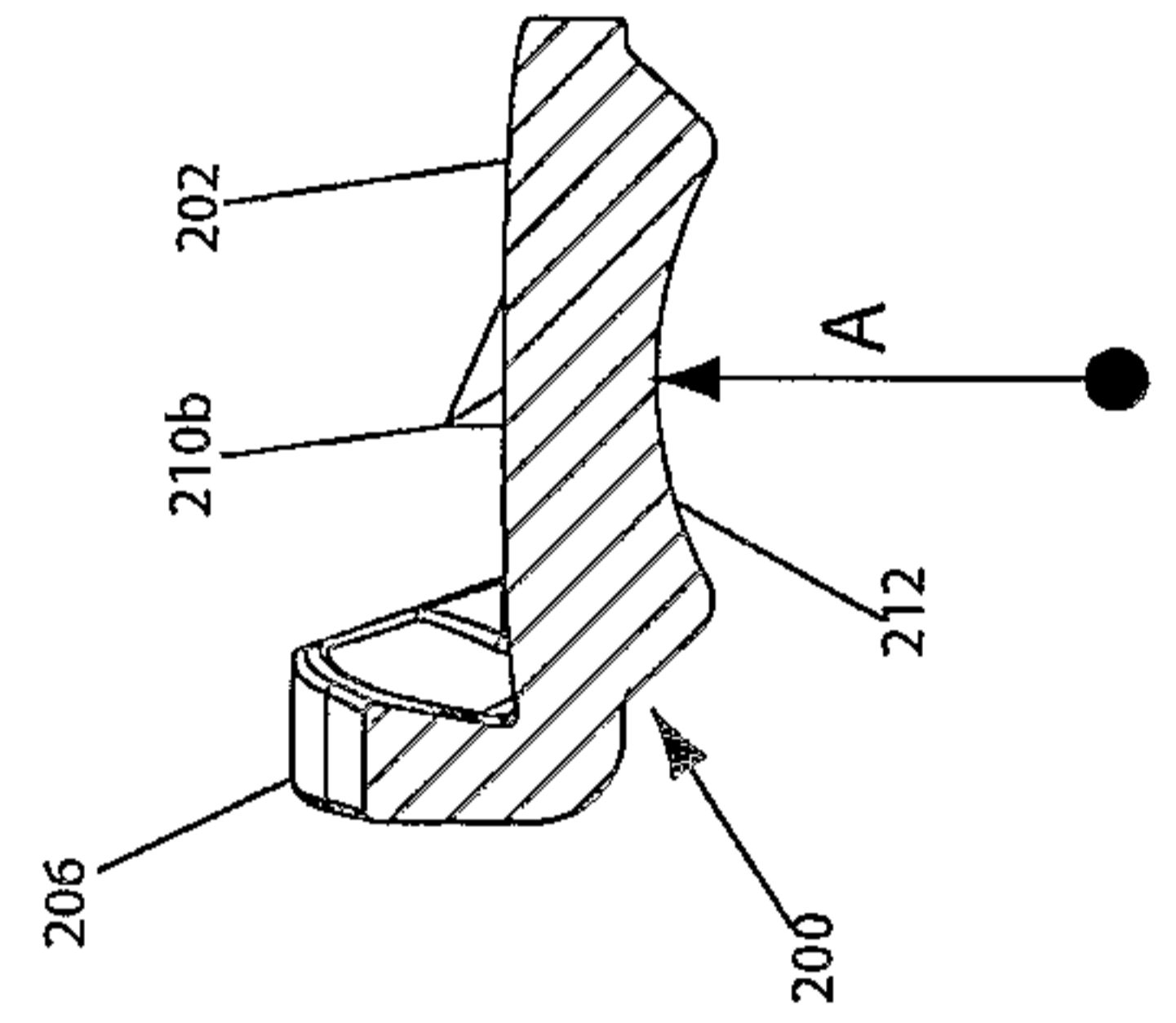

FIG. 10
SECTION A-A of FIG. 11

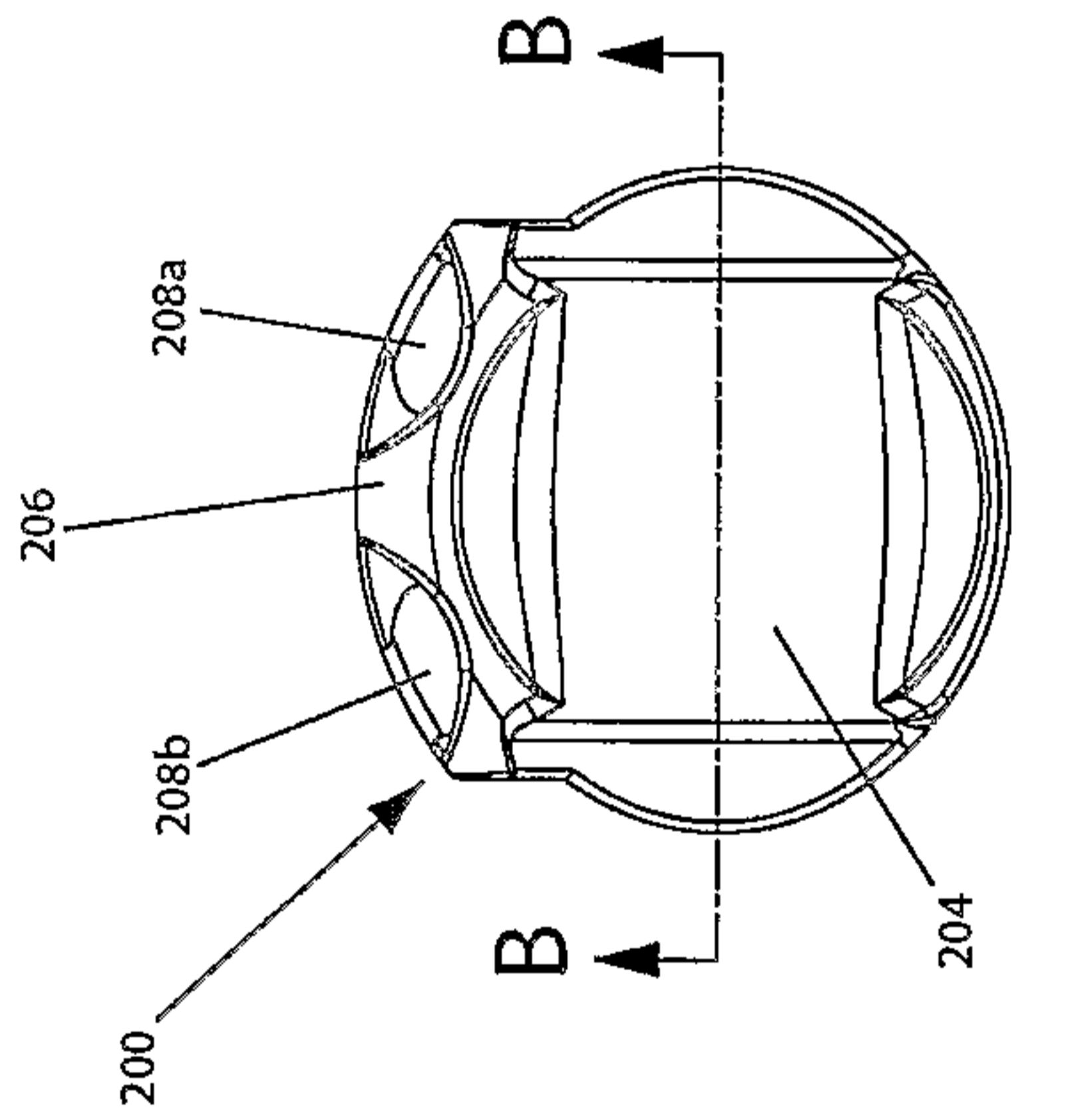

FIG. 7

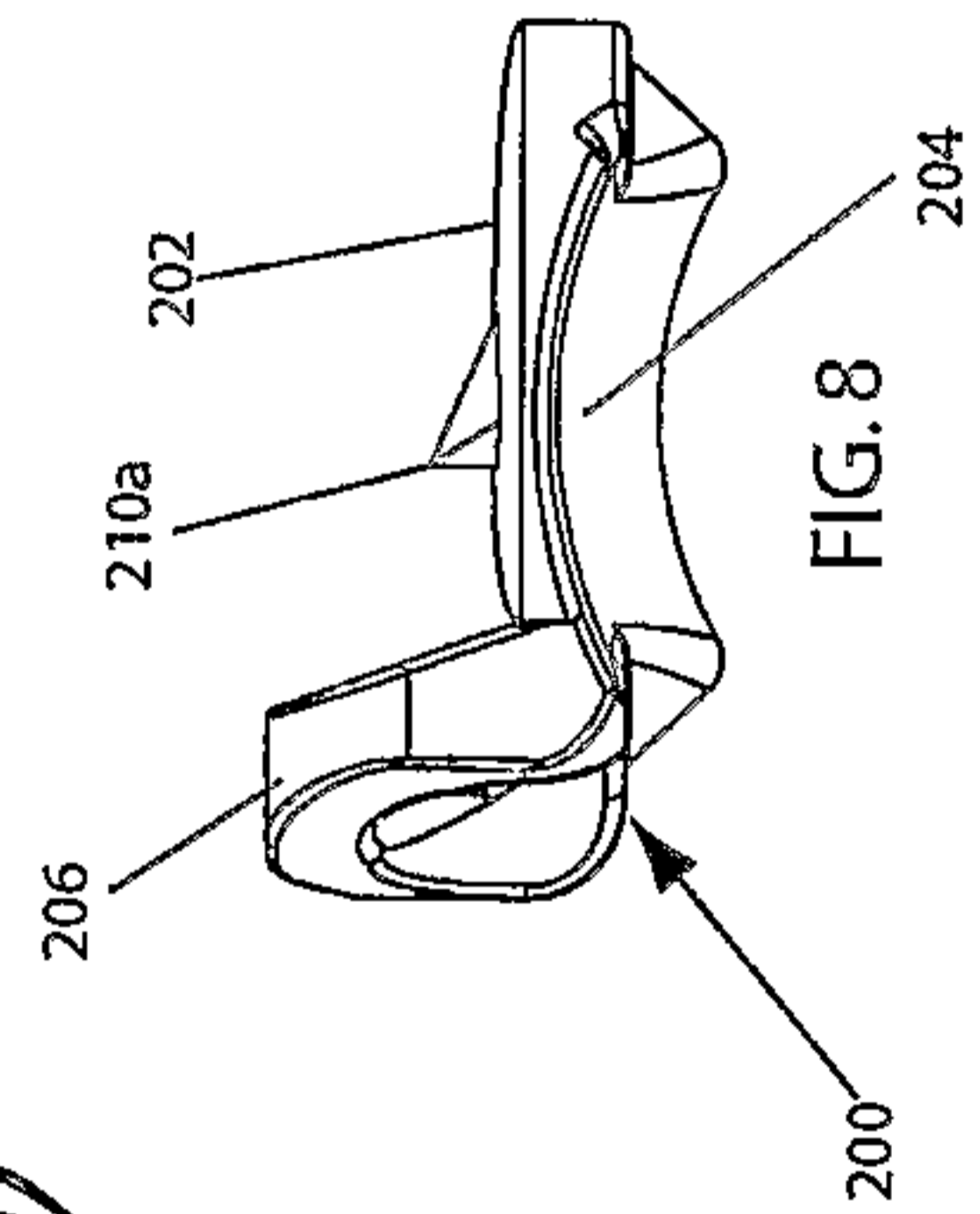

FIG. 8

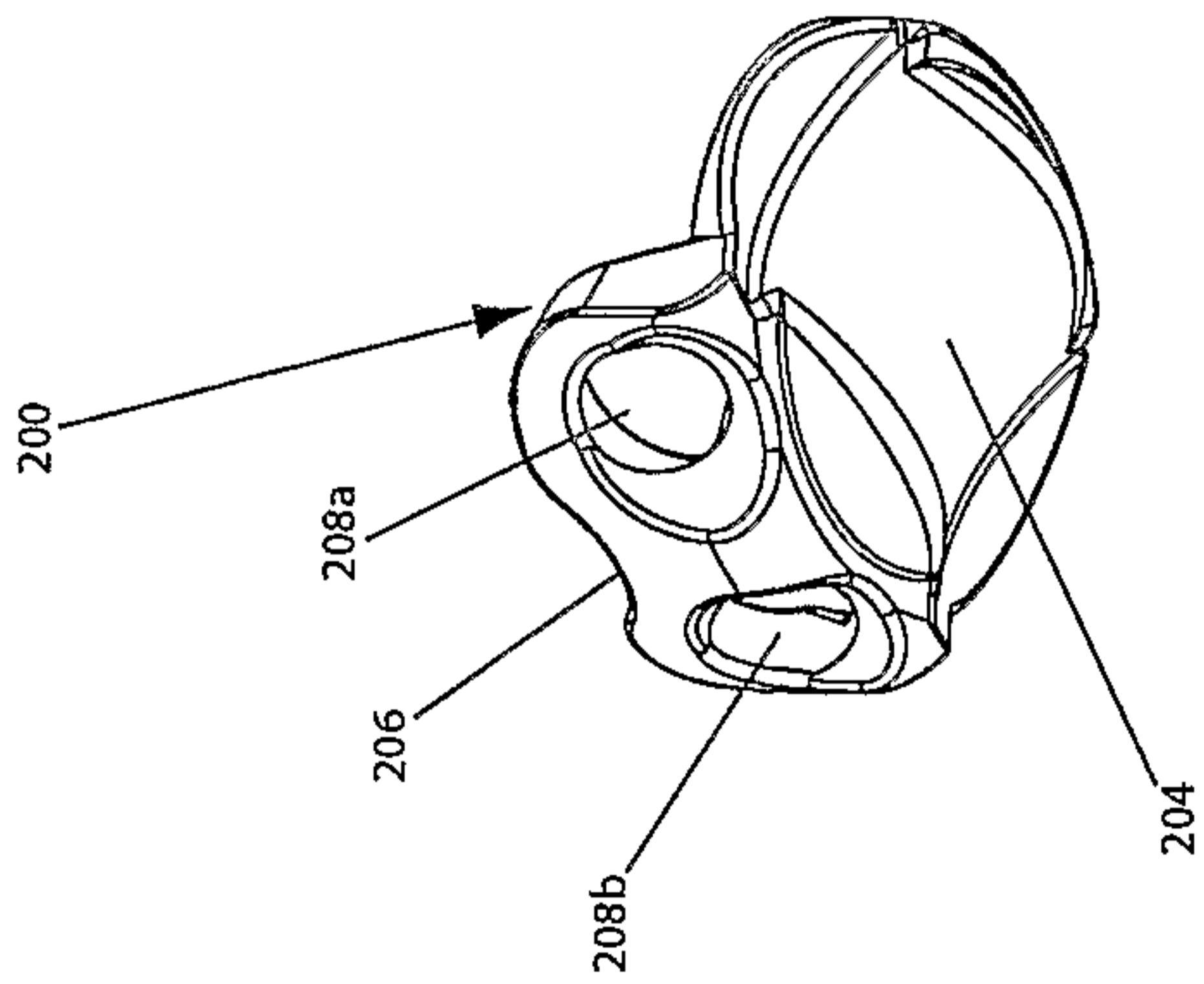

FIG. 6

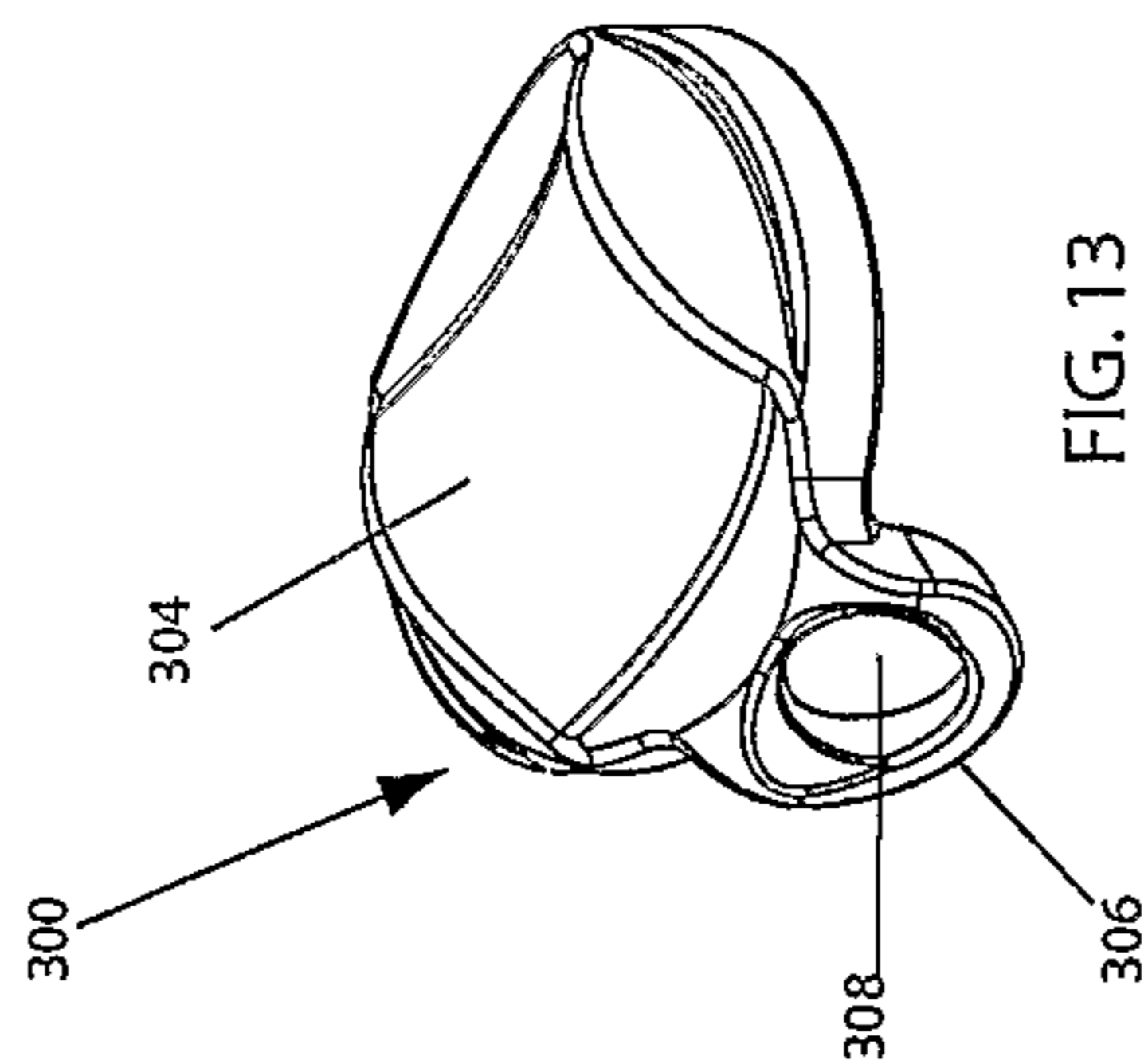

FIG. 13

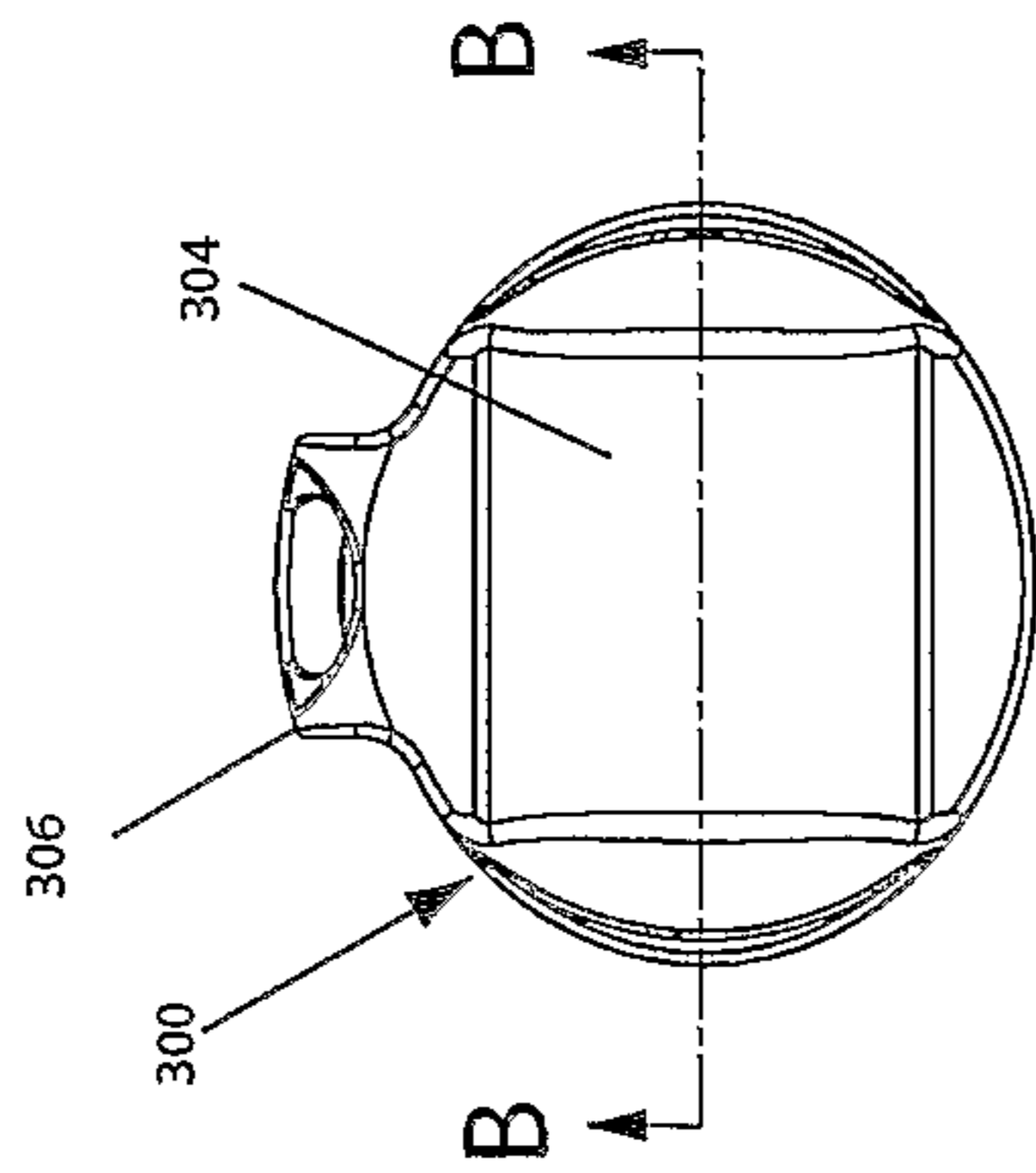

FIG. 14

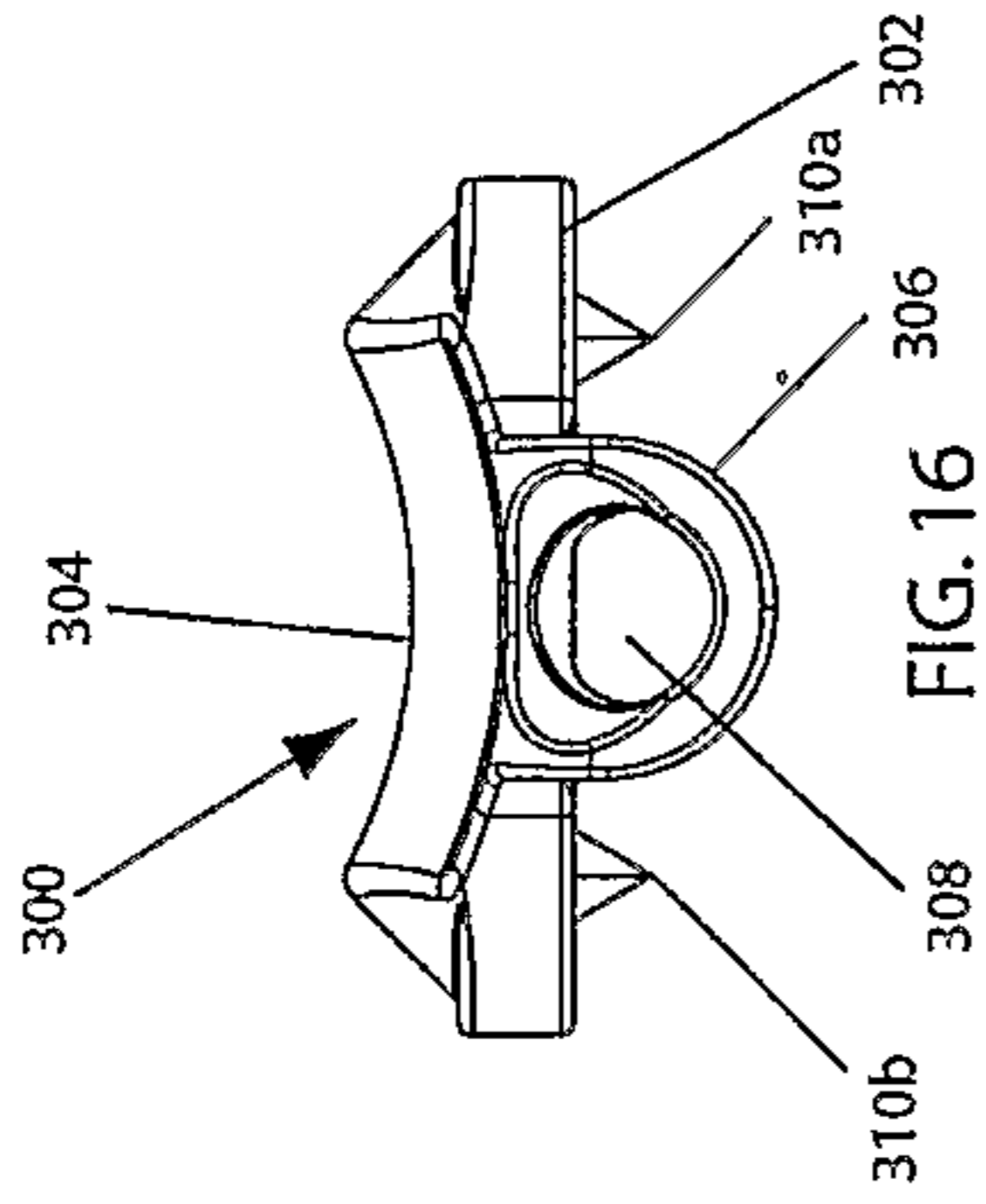

FIG. 16

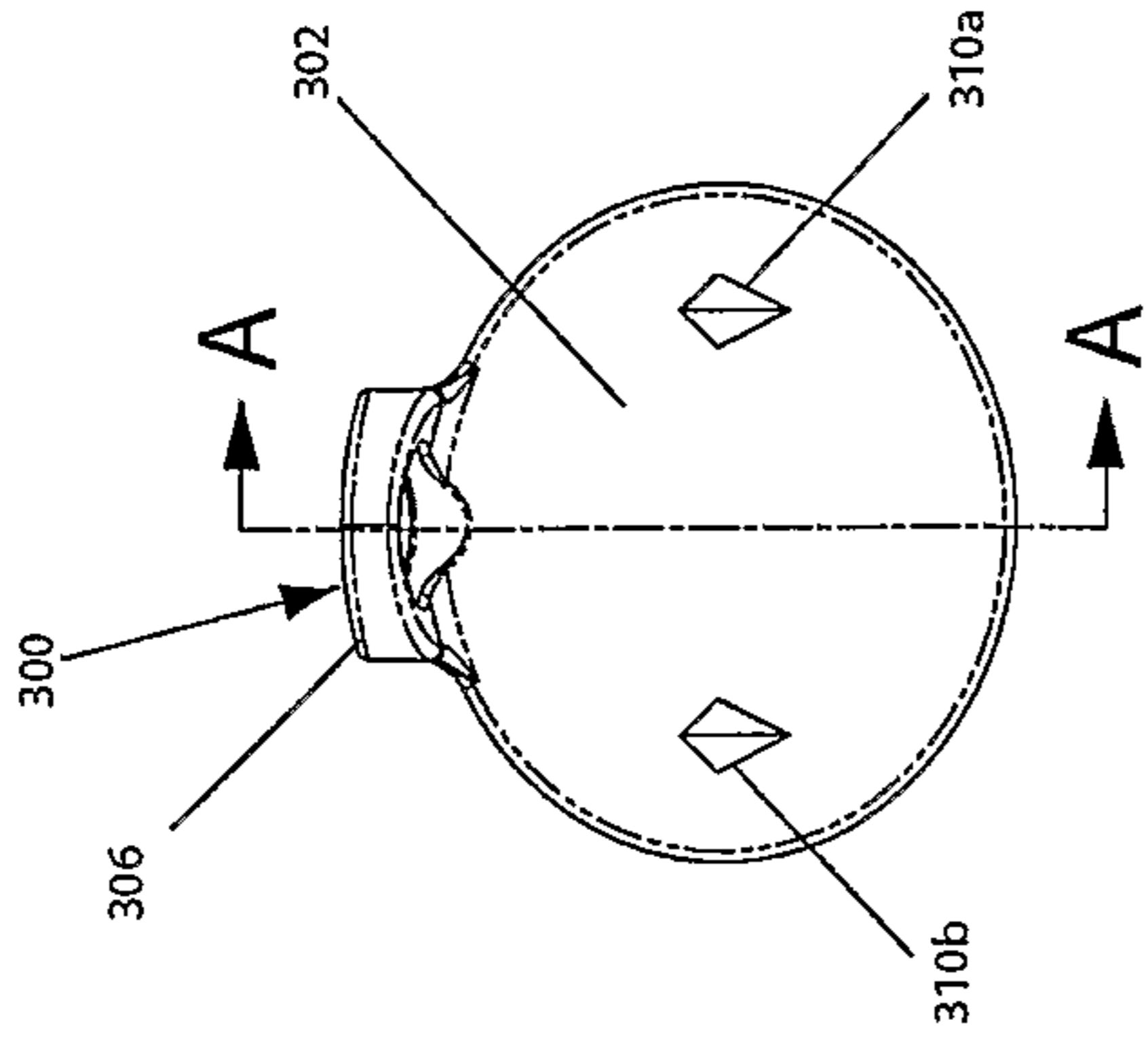

FIG. 18

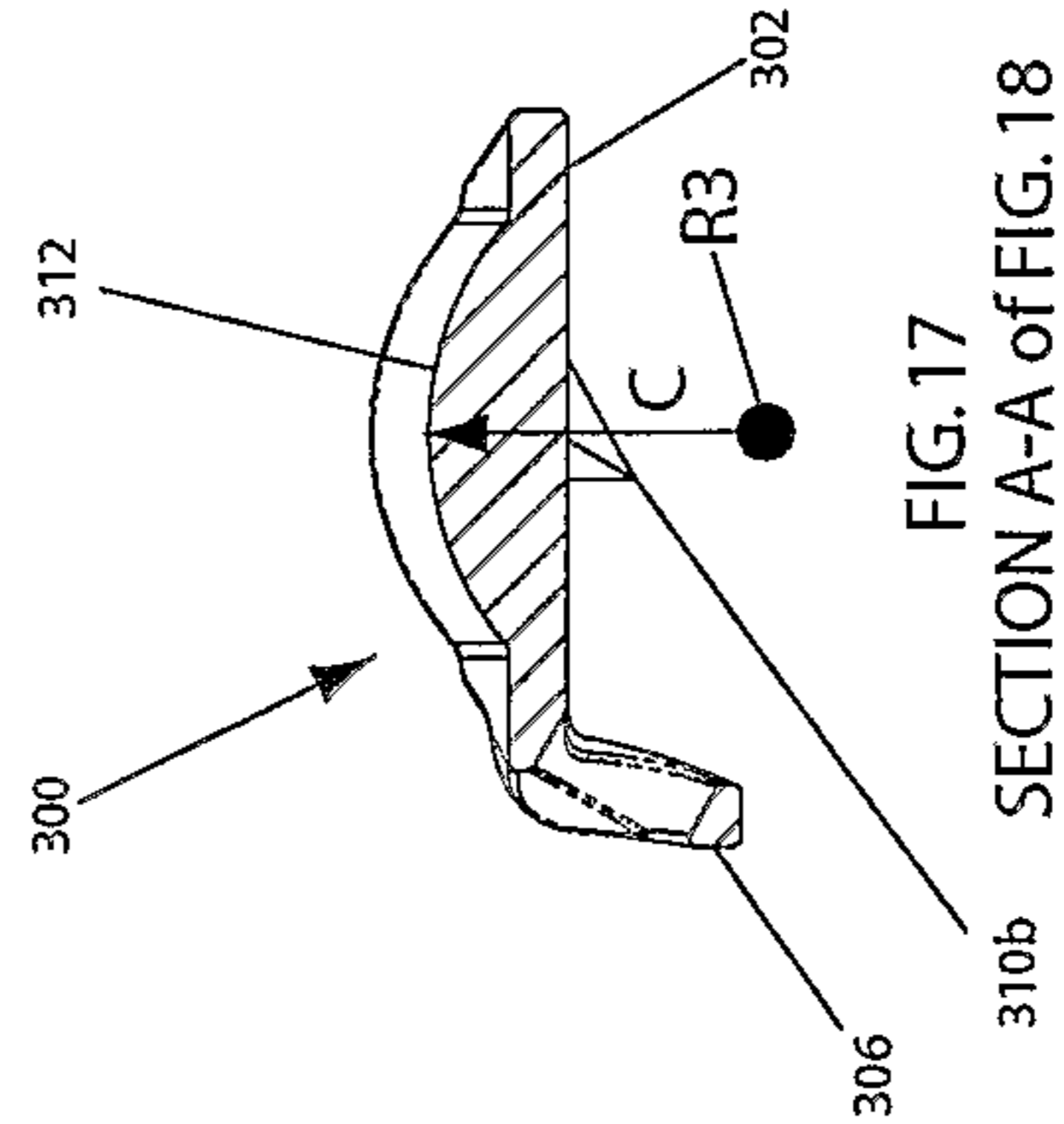

FIG. 17

SECTION A-A of FIG. 18

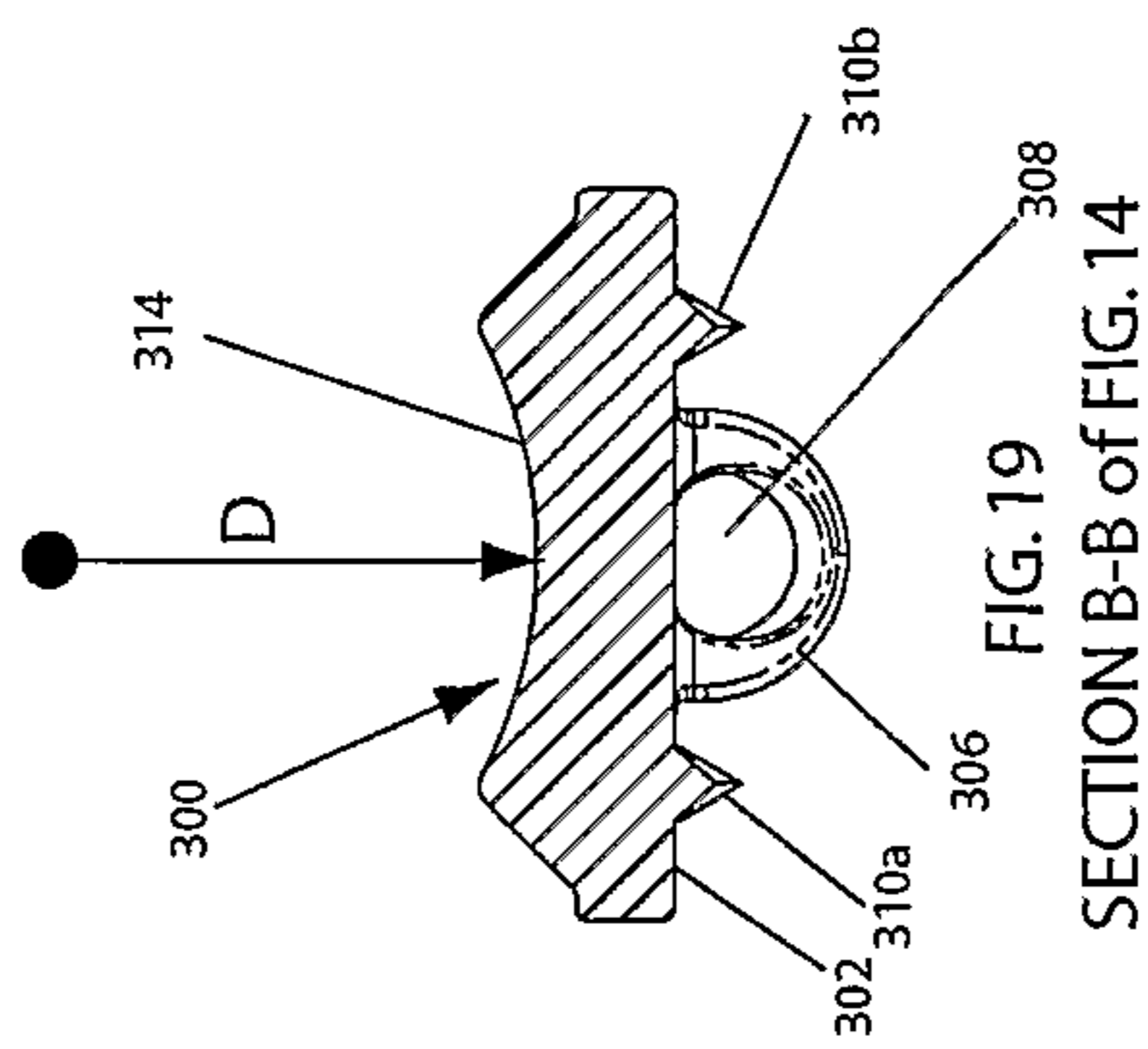

FIG. 19

SECTION B-B of FIG. 14

