

(12) INTERNATIONAL APPLICATION PUBLISHED UNDER THE PATENT COOPERATION TREATY (PCT)

(19) World Intellectual Property Organization
International Bureau



(43) International Publication Date
10 May 2001 (10.05.2001)

PCT

(10) International Publication Number
WO 01/32047 A1

- (51) International Patent Classification⁷: A45D 26/00
- (21) International Application Number: PCT/CN99/00176
- (22) International Filing Date:
1 November 1999 (01.11.1999)
- (25) Filing Language: English
- (26) Publication Language: English
- (71) Applicant: K. I. S. LTD. [CN/CN]; 520 East Ocean Centre, Tsimshatsui East, Kowloon, Hong Kong (CN).
- (72) Inventor: YIU, Waiwah; Flat H, 9/F, Tower 5, Metro City Phase I, Tseung Kwan O., Kowloon, Hong Kong (CN).
- (74) Agent: CHINA PATENT AGENT (H.K.) LTD.; 22/F, Great Eagle Centre, 23 Harbour Road, Wanchai, Hong Kong (CN).
- (81) Designated States (*national*): AE, AL, AM, AT, AU, AZ, BA, BB, BG, BR, BY, CA, CH, CN, CU, CZ, DE, DK, EE, ES, FI, GB, GD, GE, GH, GM, HR, HU, ID, IL, IN, IS, JP, KE, KG, KP, KR, KZ, LC, LK, LR, LS, LT, LU, LV, MD, MG, MK, MN, MW, MX, NO, NZ, PL, PT, RO, RU, SD, SE, SG, SI, SK, SL, TJ, TM, TR, TT, UA, UG, UZ, VN, YU, ZA, ZW.
- (84) Designated States (*regional*): ARIPO patent (GH, GM, KE, LS, MW, SD, SL, SZ, TZ, UG, ZW), Eurasian patent (AM, AZ, BY, KG, KZ, MD, RU, TJ, TM), European patent (AT, BE, CH, CY, DE, DK, ES, FI, FR, GB, GR, IE, IT, LU, MC, NL, PT, SE), OAPI patent (BF, BJ, CF, CG, CI, CM, GA, GN, GW, ML, MR, NE, SN, TD, TG).
- Published:
— With international search report.

[Continued on next page]

(54) Title: HAIR REMOVAL DEVICE WITH DISC ASSEMBLY

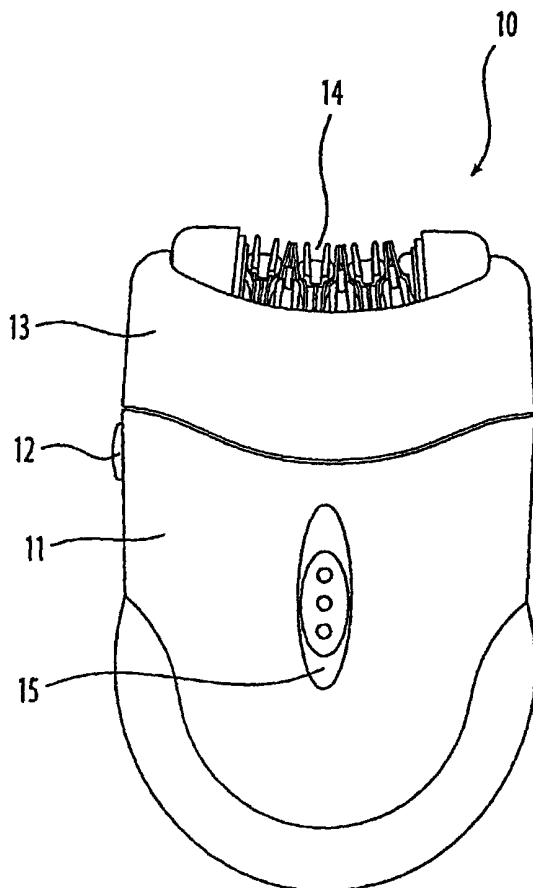

(57) Abstract: A device for removing unwanted hair, including a housing and a hair-plucking assembly, rotatably mounted to the housing, wherein the hair-plucking assembly comprises at least one disc assembly, wherein the disc assembly comprises an insert disc having at least one arm and two outer discs having at least one arm apiece, wherein the arms of the outer discs may be pressed against the arm of the insert disc to form two traps for hair.



WO 01/32047 A1



For two-letter codes and other abbreviations, refer to the "Guidance Notes on Codes and Abbreviations" appearing at the beginning of each regular issue of the PCT Gazette.

HAIR REMOVAL DEVICE WITH DISC ASSEMBLY

5

FIELD OF THE INVENTION

The present invention relates generally to a depilatory device for removal of unwanted hair, and more specifically, to a device for removing unwanted hair by
10 trapping and uprooting the hair.

BACKGROUND OF THE INVENTION

There exists a need for the removal of unwanted hair to maintain a desirable physical appearance. There are
15 many different devices known in the art that are useful for removing unwanted hair, such as razors, tweezers, and other depilatory devices.

Although razors provide quick and easy hair removal, hair remains visible at the surface of the skin and
20 quickly regrows. Therefore one must shave frequently in order to maintain smooth skin and a desired appearance. Tweezers also may be used. Prior art tweezers comprise two arms that are resiliently biased away from each other, each arm having an opposing surface. The hair is positioned
25 between the two opposing surfaces, and the arms are pressed together, thereby grasping the hair between the two opposing surfaces of the tweezer arms. The hair is then plucked from the body. Tweezers provide longer-lasting hair removal. However, removing hair with tweezers is a tedious process
30 since traditional tweezers can only remove one hair at a time. In addition, precise handling is required in order to position and grasp the hair between the two, usually small, opposing surfaces.

In processes involving the uprooting of hair, care
35 must be taken so that the hair is not inadvertently cut. In addition, it is desirable to pull out as many hairs as

quickly as possible so as not to prolong this painful process.

Various devices are known in the art for hair removal, such as is described in U.S. Patent No. 5,281,233 to 5 Dolev ("Dolev patent"). The Dolev hair removal device generally comprises a housing and a hair-plucking assembly rotatably mounted to the housing. The hair plucking assembly includes at least one disc assembly comprising (i) a pair of complementary discs, each of the discs having at least three 10 radially extending arms terminating in flattened peripheral portions which, when pressed against the corresponding portion of the arms of the other disc forms a trap for the hair; and (ii) a hub for accommodating and rotating the pair of discs so that the flattened peripheral portions of the 15 discs are alternately brought together to form a trap and apart to eject the removed hair.

There is a need, however, for a depilatory device, which is as easy and inexpensive to assemble and maintain as prior art devices, but has an even larger trap area for grasping 20 unwanted hair so that a greater number of hairs may be uprooted than is currently possible.

SUMMARY OF THE INVENTION

The present invention relates to a depilatory device for 25 efficient removal of unwanted hair by uprooting the hair, said device generally comprising a housing and a hair-plucking assembly rotatably mounted to the housing, wherein the hair-plucking assembly comprises at least one disc assembly having six hair traps.

30 More specifically, the at least one disc assembly comprises (i) three complementary discs, including two outer discs and an internal disc, each of the discs having at least three radially extending arms terminating in flattened peripheral portions, wherein pressing the flattened 35 peripheral portions of the two outer discs against the corresponding portion of the internal disc forms two traps for unwanted hair; and (ii) a hub for accommodating and

rotating the three discs so that the flattened peripheral portions of the two outer discs are alternately brought together to form a trap and apart to eject the removed hair.

5 **BRIEF DESCRIPTION OF THE DRAWINGS**

Reference is next made to a brief description of the drawings, which are intended to illustrate the hair removal device according to the present invention. The drawings and detailed descriptions which follow are intended to be merely
10 illustrative, and are not intended to limit the scope of the invention as set forth in the appended claims.

FIG. 1 is a front view of a hair removal device according to the present invention.

FIG. 2 is a front cross-sectional view of the hair
15 removal device including a plurality of disc assemblies.

FIG. 3 is an exploded perspective view of a disc assembly including the two outer discs and the internal disc.

FIG. 4 is a plan view of the disc assembly of FIG. 3.

FIG. 5 is a perspective view of the disc assembly of
20 FIG. 3.

DETAILED DESCRIPTION OF THE HAIR REMOVAL DEVICE

The present invention is a hair removal device having at least one disc assembly comprising three discs, including two
25 outer discs and an internal disc, which provides for a greater hair-grasping area than prior art disc assembly hair removers.

Referring to the drawings, FIG. 1 illustrates a preferred embodiment of a hair removal device 10 according to
30 the present invention. Hair removal device 10 comprises housing 11, housing cap 13, and hair-plucking assembly 14. Housing 11 is ergonomically shaped to facilitate easy and comfortable gripping by one hand and is preferably constructed of plastic although alternative materials may
35 also be used. In addition, the orientation of housing 11 in relation to hair-plucking assembly 14 may be varied in any number of alternative configurations to optimize efficiency

and convenience of use. Examples of suitable alternative configurations are described in the Dolev patent, incorporated herein by reference in its entirety. Hair-plucking assembly 14 partially extends through an opening in housing cap 13, and can be removed, for cleaning or maintenance, by pressing release button 12.

Motor 216, which is contained within housing 11, may be any of a wide variety of miniature motors. Motor 216 may be operated by any convenient and available power source, including house current or a battery (not shown). Hair-plucking assembly 14 is powered by motor 216, which is activated by on/off switch 15.

In the hair removal device illustrated in FIG. 2, motor housing 218 contains both motor 216 and a reduction gear system, which converts the rotational speed produced by motor 216 to the proper rotational speed of hair-plucking assembly 14. Any suitable reduction gear system may be used. In detail, motor shaft 202 is connected to motor shaft gear 203 which meshes with a larger reduction gear 204 mounted on reduction gear shaft 205. The rotational speed of reduction gear 204 is then transmitted to drive gear 208 of hair-plucking assembly 14 by transmission gear 206 mounted on transmission gear shaft 207. As known in the art, each gear may either be connected to or integrally formed with its corresponding shaft. In addition, any system that provides adequate rotational motion to hair-plucking assembly 14 may be incorporated into the hair removal device of the present invention.

Hair-plucking assembly 14 is made up of at least one disc assembly 500. As shown in FIG. 2, the preferred embodiment includes six disc assemblies 500, and all disc assemblies 500 are identical. Each disc assembly 500 is symmetric with respect to clockwise or counterclockwise rotation. Adjacent disc assemblies 500 are engaged to each other by engagement means comprising engagement protrusions 303 and engagement recessions 304 (shown in FIG. 4) along curved shaft 214. These engagement protrusions 303 and

recessions 304 ensure that adjacent disc assemblies 500 are angularly offset from one another by appropriate angles and also ensures that adjacent disc assemblies 500 interact properly to form effective hair traps. Curved shaft 214 may
5 be made of any appropriate material, including various rigid or flexible materials. Appropriate support must be provided for a curved shaft made of a flexible material.

In addition, orientation of hair-plucking assembly 14 is separately controlled by left bracket 201 and right bracket
10 213. Furthermore, two sets of bearings 210 are placed at the end of hair-plucking assembly 14 to provide smooth and steady rotation while the rotational speed is transmitted from the drive gear 208 to bearing support 209.

As shown in FIG. 3, disc assembly 500 comprises three
15 main elements, including an internal disc assembly 301, and a pair of outer discs 212. Each internal disc assembly 301 comprises disc carrier 302 and insert disc 501. Preferably, disc carrier 302 is made of a plastic material such as Acetal plastic and insert disc 501 and outer discs 212 are made of
20 stainless steel. In other words, the portions of disc assembly 500, intended for contact with the hair are made of a metal material, which is particularly effective for plucking hair, and the portions of disc assembly 500, which contact curved shaft 214, are made of plastic to facilitate
25 smooth rotation of the disc assembly 500. Alternatively, these components may be made by other appropriate materials known in the art.

As shown in FIGS. 3, 4, and 5, each insert disc 501 and all outer discs 212 include three radially extending arms 401
30 oriented approximately 120° apart. Each arm 401 terminates in flattened peripheral portion 402. Flattened peripheral portions 402 are constructed such that when the flattened peripheral portions 402 of the pair of outer discs 212 of each disc assembly 500 are pressed against the corresponding
35 flattened peripheral portion 502 of insert disc 501, two traps are formed, which tend to grasp and hold any hair, by the peripheral portions 502 and 402 as shown in FIG. 5. In

other words, two traps are formed to grasp hair when a pair of opposing clamping forces are applied to flattened peripheral portions 401 of outer discs 212. Therefore, six traps may be activated for a 360° rotation of disc assembly 500.

As illustrated in FIG. 2, hair removal device 10 includes six sets of disc assemblies 500. Each disc assembly 500 is mounted adjacently to at least one other disc assembly 500 on curved shaft 214, and all six sets of disc assemblies 500 are bounded by left bracket 201 and right bracket 213. In addition, the upper dimension between left bracket 201 and right bracket 213 are designed such that disc assemblies 500 may properly rotate in an inclined angle as shown in FIG. 2, thereby forming effective hair traps.

The central portion of each outer disc 212 includes a generally circular opening, which is sized and shaped so that each outer disc 212 may be mounted on internal disc assembly 301. The configuration, i.e., dimensions and tolerances, of all components 212, 303 of each disc assembly 500 is designed such that these components fit snugly together and remain engaged during operation of the device 10.

In alternative embodiments of hair removal device 10, disc assembly 500 may comprise one or two integral pieces having between them all the elements of the three components 212, 303 discussed above. The materials must be chosen so as to enable such an alternative embodiment to form effective hair grasping traps.

Disc carrier 302 of internal disc assembly 301 comprises three U-shaped members 305, which extend to approximately the same radial distance as radially extending arms 401. Rotational motion is imparted either clockwise or counterclockwise to outer discs 212 by these U-shaped members 305. Extending from each of the two arms of each U-shaped member 305 is a pincher 306. In other words, each U-shaped member 305 has a pair of opposing pinchers 306. Pinchers 306 extend beyond the plane of radially extending arms 401 such that as disc assembly 500 rotates, pinchers 306 come into

contact with and thereby imparts clamping forces to the radially extending arm 401 of adjacent disc assemblies 500, which causes adjacent disc assemblies 500 to form traps. Disc assemblies 500 are configured and assembled within the 5 device such that pinchers 306 of each disc assembly 500 remain adjacent to radially extending arms 401 of adjacent disc assemblies 500 during rotation of all disc assemblies 500.

All clamping forces are applied to flattened peripheral 10 portions 402 of the outer discs 212. Hence, the traps formed between the pair outer discs 212 and internal disc assembly 301 of each disc assembly 500 serve to grasp hair and remove it by means of the power provided by motor 216.

The present invention may be embodied in other forms 15 without departing from its spirit or essential characteristics. The described embodiments are to be considered only as illustrative and not as restrictive. For example, each disc assembly 500 does not necessarily require three sets of radially extending arms 401. More arms may be 20 incorporated into the design of the present invention, thereby providing more traps per disc assembly rotation. Additional means also may be incorporated into the design to prolong the time during which the traps are formed as described in the Dolev patent. The scope of the invention 25 is, therefore, indicated by the appended claims.

30

35

What Is Claimed:

1. A hair removal device comprising:
- (A) a housing;
- 5 (B) a hair-plucking assembly rotatably mounted to the housing, wherein the hair-plucking assembly includes at least one disc assembly, said disc assembly comprising:
- (i) an internal disc assembly comprising an
10 insert disc, having at least one arm, mounted on a disc carrier;
- (ii) a pair of outer discs mounted on the internal disc assembly, wherein each outer disc has at least one arm, both of which may
15 be pressed against the at least one arm of the internal disc to form two traps for hair,
- wherein the disc carrier comprises:
- (a) at least one U-shaped member for engaging
20 the at least one arm of each of the pair of outer discs so as to impart rotational motion to the pair of outer discs upon rotation of the internal disc assembly about an axis of the internal disc assembly;
- (b) at least a pair of pinchers which extend
25 axially from the at least one U-shaped member beyond the plane of the arm of each of the pair of outer discs for imparting a clamping force on at least one adjacent disc carrier;
and
- (c) engagement means for engaging at least one
30 adjacent disc carrier so that rotational movement of one disc carrier imparts rotational motion to at least one adjacent disc carrier.

35

2. The hair removal device of claim 1, wherein the disc carrier is made of Acetal plastic and the insert disc and the pair of outer discs are made of stainless steel.

5 3. The hair removal device of claim 1, wherein each arm of each outer disc terminates in a flattened peripheral portion.

4. The hair removal device of claim 1, further
10 comprising a housing cap removably mounted on the housing, wherein the housing cap has an opening through which the hair-plucking assembly partially extends.

5. The hair removal device of claim 1, wherein the
15 engagement means comprises engagement protrusions and engagement recessions for engaging corresponding protrusions and recessions of at least one adjacent disc carrier.

6. The hair removal device of claim 1, wherein the
20 hair-plucking assembly comprises a plurality of identical disc assemblies.

7. The hair removal device of claim 1, wherein the
hair-plucking assembly is rotatably mounted on a shaft.
25

8. The hair removal device of claim 7, wherein the shaft is curved.

9. The hair removal device of claim 1, further
30 comprising a left bracket and right bracket mounted to the housing for controlling the orientation and rotation of the hair-plucking assembly.

10. A hair removal device comprising:
35 (A) a housing;
(B) a hair-plucking assembly rotatably mounted to a curved shaft mounted in the housing, wherein the

hair-plucking assembly includes six identical disc assemblies, each of which comprise:

5 (i) an internal disc assembly comprising an insert disc, having three arms, mounted on a disc carrier;

(ii) a pair of outer discs mounted on the internal disc assembly, having three pairs of arms, each of which may be alternately pressed against the three arms of the internal disc to form six traps for hair,

10 wherein the disc carrier comprises:

(a) three U-shaped members for engaging the three pairs of arms of the pair of outer discs so as to impart rotational motion to the pair of outer discs upon rotation of the internal disc assembly about an axis of the internal disc assembly;

15 (b) three pairs of pinchers which extend axially from each of the three U-shaped members beyond the plane of the arms of each pair of outer discs for imparting a clamping force on at least one adjacent disc carrier; and

20 (c) engagement means for engaging at least one adjacent disc carrier so that rotational movement of one disc carrier imparts rotational motion to at least one adjacent disc carrier.

30

35

1/4

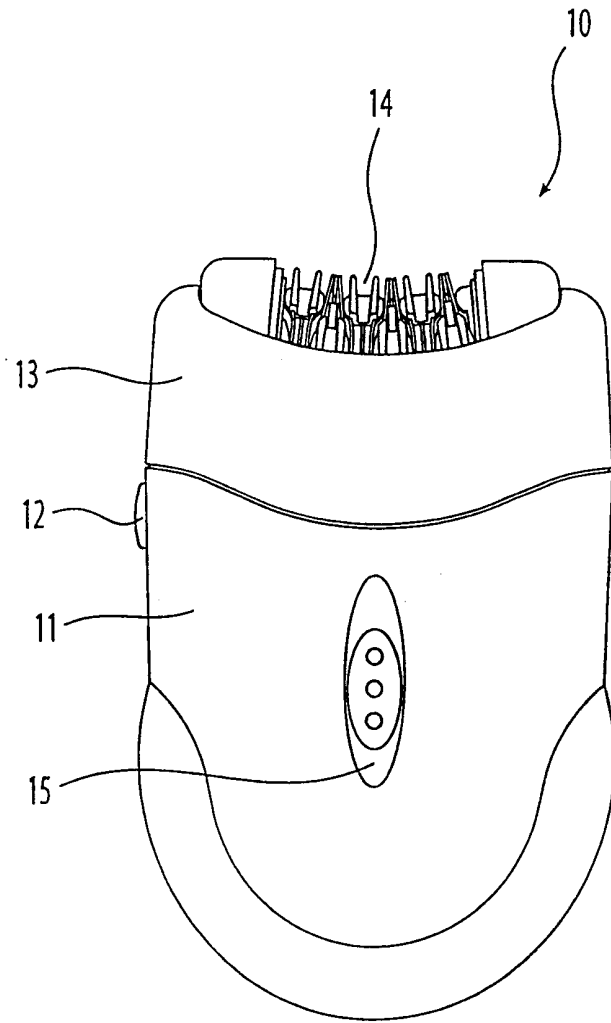

Fig. 1

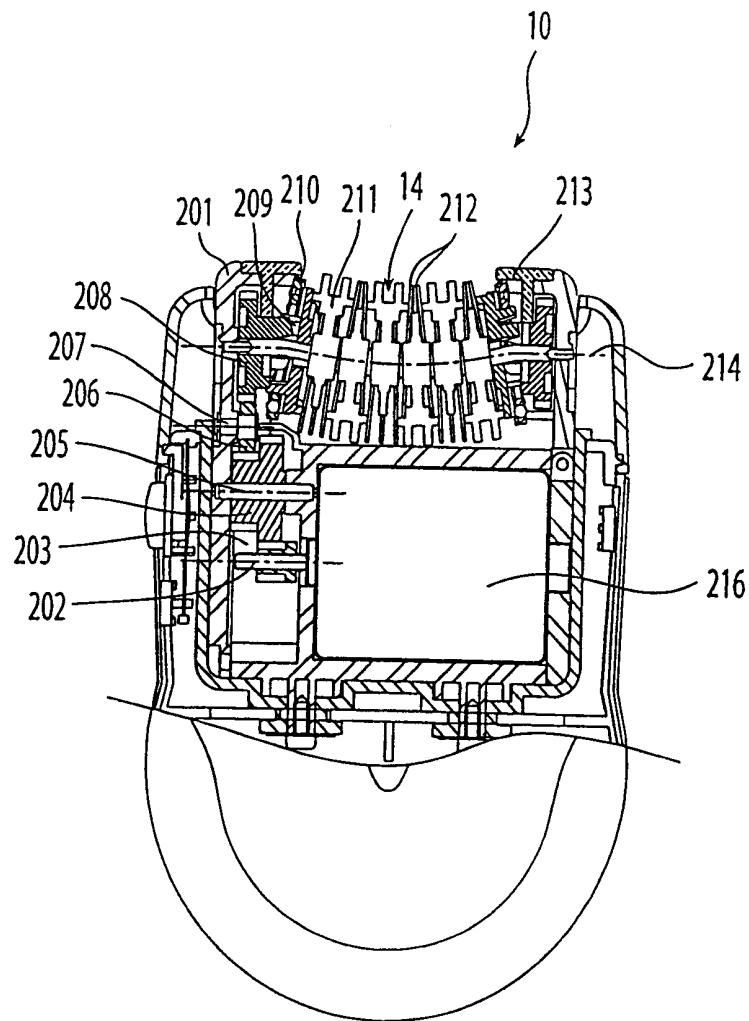

Fig. 2

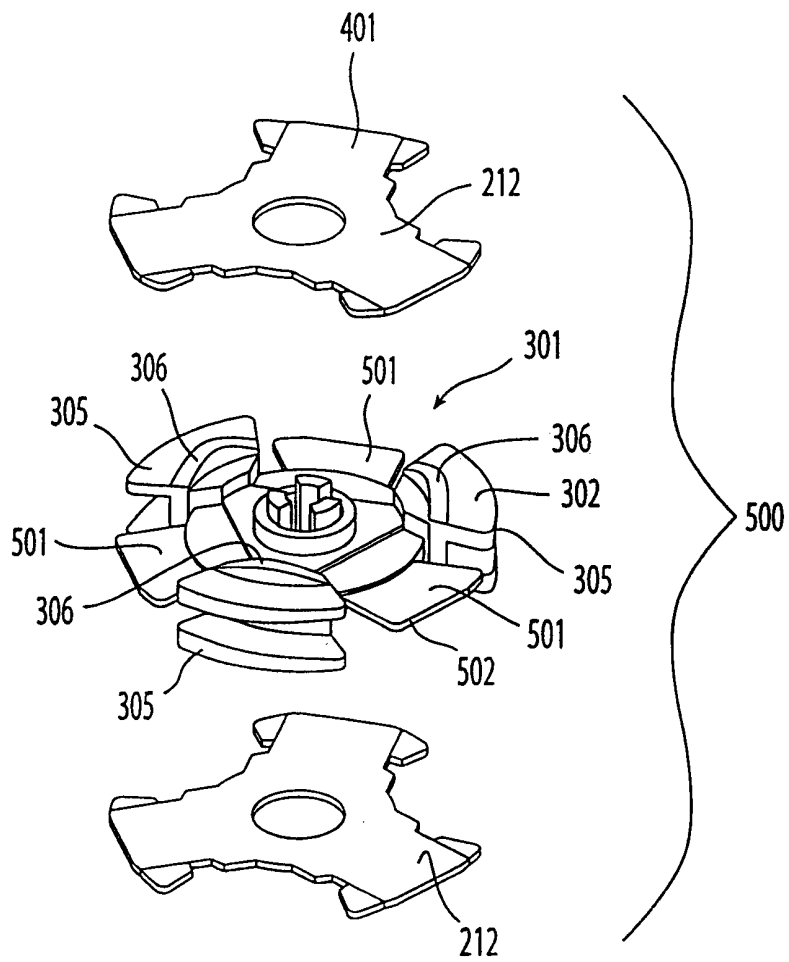

Fig. 3

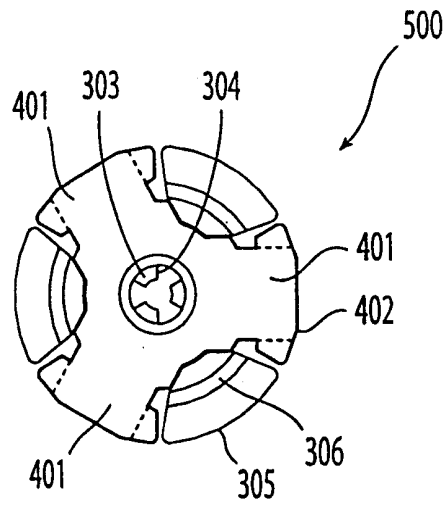

Fig. 4

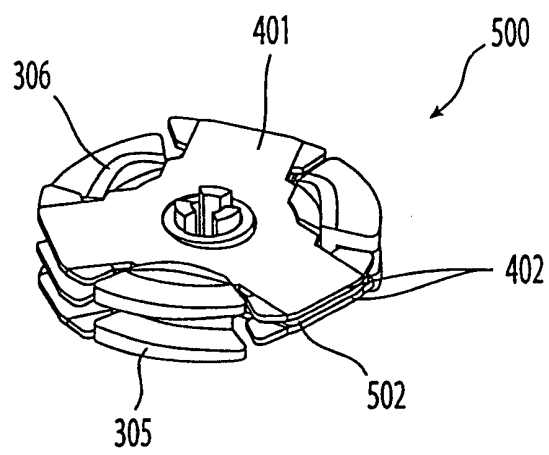
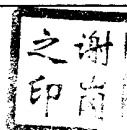

Fig. 5

INTERNATIONAL SEARCH REPORT

International application No.
PCT/CN99/00176

A. CLASSIFICATION OF SUBJECT MATTER		
A45D26/00		
According to International Patent Classification (IPC) or to both national classification and IPC		
B. FIELDS SEARCHED		
Minimum documentation searched (classification system followed by classification symbols)		
IPC7 A45D		
Documentation searched other than minimum documentation to the extent that such documents are included in the fields searched		
Electronic data base consulted during the international search (name of data base and, where practicable, search terms used)		
WPI, EPODOC, PAJ		
C. DOCUMENTS CONSIDERED TO BE RELEVANT		
Category*	Citation of document, with indication, where appropriate, of the relevant passages	Relevant to claim No.
A	EP,A,613,632 (DOLEV, Moshe) 07 September 1994 see the whole document	1-10
A	EP,A,383,719 (DOLEV, Moshe) 22 August 1990 see the whole document	1-10
A	CN,A,1,231,864 (IWASAKI JYUZAEMON) 20 October 1999 see the whole document	1-10
A	CN,A,1,155,234 (ERBERT, KARL) 23 July 1997 see the whole document	1-10
<input type="checkbox"/> Further documents are listed in the continuation of Box C. <input checked="" type="checkbox"/> See patent family annex.		
<p>* Special categories of cited documents:</p> <p>"A" document defining the general state of the art which is not considered to be of particular relevance</p> <p>"E" earlier application or patent but published on or after the international filing date</p> <p>"L" document which may throw doubts on priority claim (S) or which is cited to establish the publication date of another citation or other special reason (as specified)</p> <p>"O" document referring to an oral disclosure, use, exhibition or other means</p> <p>"P" document published prior to the international filing date but later than the priority date claimed</p>	<p>"T" later document published after the international filing date or priority date and not in conflict with the application but cited to understand the principle or theory underlying the invention</p> <p>"X" document of particular relevance: the claimed invention cannot be considered novel or cannot be considered to involve an inventive step when the document is taken alone</p> <p>"Y" document of particular relevance: the claimed invention cannot be considered to involve an inventive step when the document is combined with one or more other such documents, such combination being obvious to a person skilled in the art</p> <p>"&" document member of the same patent family</p>	
Date of the actual completion of the international search 28 July 2000 (28.07.00)		Date of mailing of the international search report 10 AUG 2000 (10.08.00)
Name and mailing address of the ISA/CN 6 Xitucheng Rd., Jimen Bridge, Haidian District. 100088 Beijing, China Facsimile No. 86-10-62019451		Authorized officer Xie Gang Telephone No. 86-10-62093950



INTERNATIONAL SEARCH REPORT

International application No.

PCT/CN99/00176

Box III TEXT OF THE ABSTRACT (Continuation of item 5 of the first sheet)

EP.A,613,632	07-09-1994	US-A-5281233	25-01-1994
EP.A,383,719	22-08-1990	US-A-4935024	19-06-1990
		JP-A-3029605	07-02-1991
		IL-A-89290	18-08-1992
CN,A,1,231,864	20-10-1999	EP-A-950365	20-10-1999
CN,A,1,155,234	23-07-1997	DE-A-4427788	15-02-1996
		WO-A-9604815	22-02-1996
		EP-A-0774912	28-05-1997
		JP-A-10503687T	07-04-1998
		AT-A-175324T	15-01-1999