



(86) Date de dépôt PCT/PCT Filing Date: 2009/05/20
 (87) Date publication PCT/PCT Publication Date: 2009/12/10
 (85) Entrée phase nationale/National Entry: 2010/11/26
 (86) N° demande PCT/PCT Application No.: US 2009/044605
 (87) N° publication PCT/PCT Publication No.: 2009/148822
 (30) Priorité/Priority: 2008/06/05 (US12/133,917)

(51) Cl.Int./Int.Cl. *F28D 7/00* (2006.01),
F28D 7/02 (2006.01)
 (71) Demandeur/Applicant:
LUMMUS TECHNOLOGY INC., US
 (72) Inventeurs/Inventors:
KARRS, MARK S., US;
CHUNANGAD, KRISHNAN S., US;
MASTER, BASHIR I., US
 (74) Agent: SMART & BIGGAR

(54) Titre : ECHANGEUR THERMIQUE VERTICAL COMBINE ENTRE ALIMENTATION ET EVACUATION, AVEC ANGLE VARIABLE DES CHICANES

(54) Title: VERTICAL COMBINED FEED/EFFLUENT HEAT EXCHANGER WITH VARIABLE BAFFLE ANGLE

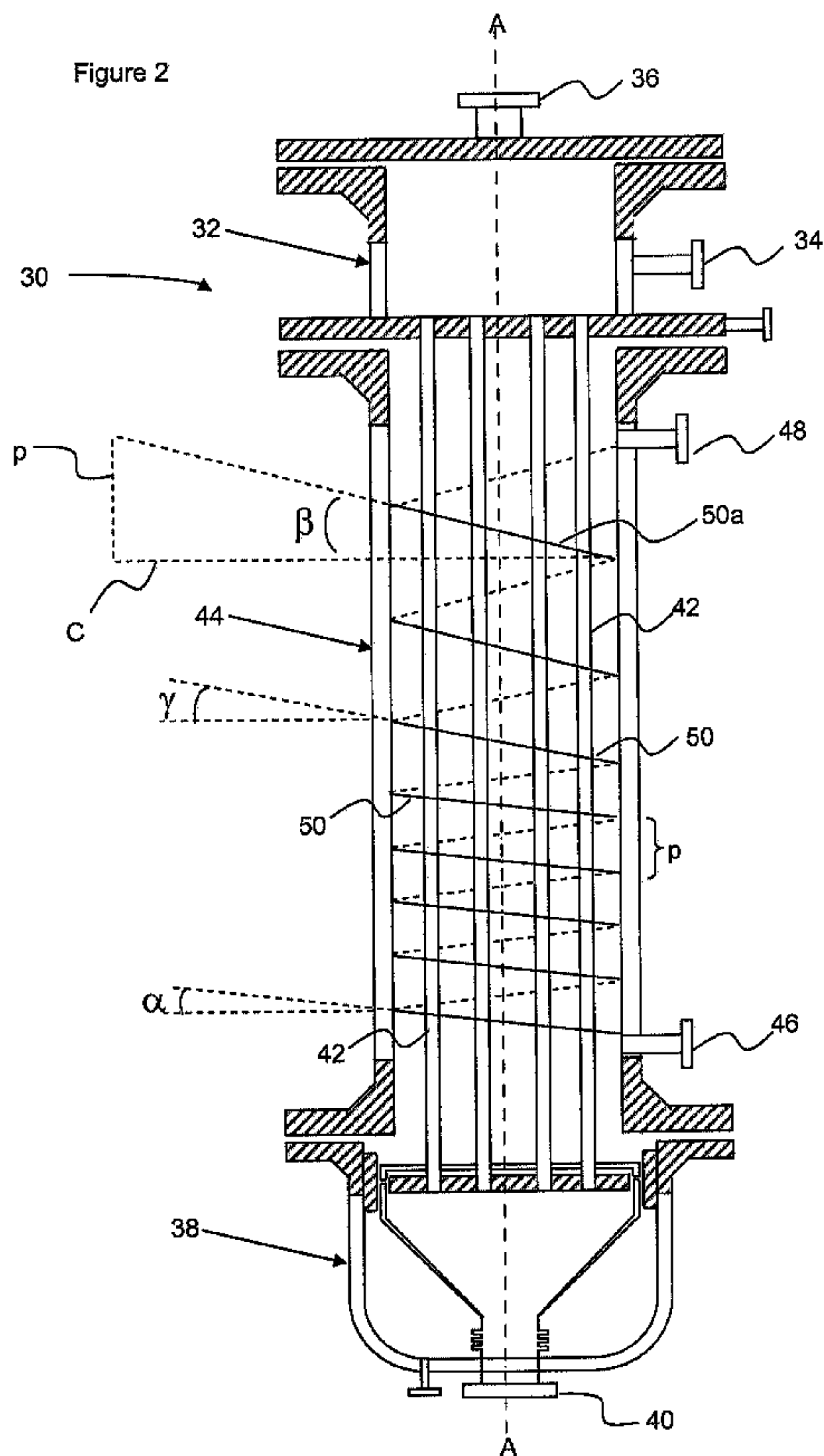

(57) **Abrégé/Abstract:**

A shell and tube heat exchanger, such as a vertical combined feed / effluent heat exchanger (VCFE), including: a shell having a fluid inlet and a fluid outlet; a plurality of baffles mounted in the shell to guide the fluid into a helical flow pattern through the shell; wherein a helix angle α of a baffle proximate the inlet is different than a helix angle β of a baffle proximate the outlet.

(12) INTERNATIONAL APPLICATION PUBLISHED UNDER THE PATENT COOPERATION TREATY (PCT)

(19) World Intellectual Property Organization
International Bureau(43) International Publication Date
10 December 2009 (10.12.2009)(10) International Publication Number
WO 2009/148822 A3(51) International Patent Classification:
F28D 7/00 (2006.01) *F28D 7/02* (2006.01)(21) International Application Number:
PCT/US2009/044605(22) International Filing Date:
20 May 2009 (20.05.2009)

(25) Filing Language: English

(26) Publication Language: English

(30) Priority Data:
12/133,917 5 June 2008 (05.06.2008) US(71) Applicant (for all designated States except US): **LUMMUS TECHNOLOGY INC.** [—/US]; 1515 Broad Street, Bloomfield, NJ 07003-3096 (US).

(72) Inventors; and

(75) Inventors/Applicants (for US only): **KARRS, Mark, S.** [US/US]; 5 Eugene Circle, Lincoln Park, NJ 07035 (US). **CHUNANGAD, Krishnan, S.** [US/US]; 508 King Place, Landing, NJ 07850 (US). **MASTER, Bashir, I.** [US/US]; 40 Hamilton Avenue, Wayne, NJ 07470 (US).(74) Agents: **BERGMAN, Jeffrey, S.** et al.; Osha . Liang LLP, 909 Fannin Street, Suite 3500, Houston, TX 77010 (US).

(81) Designated States (unless otherwise indicated, for every kind of national protection available): AE, AG, AL, AM, AO, AT, AU, AZ, BA, BB, BG, BH, BR, BW, BY, BZ, CA, CH, CN, CO, CR, CU, CZ, DE, DK, DM, DO, DZ, EC, EE, EG, ES, FI, GB, GD, GE, GH, GM, GT, HN, HR, HU, ID, IL, IN, IS, JP, KE, KG, KM, KN, KP, KR, KZ, LA, LC, LK, LR, LS, LT, LU, LY, MA, MD, ME, MG, MK, MN, MW, MX, MY, MZ, NA, NG, NI, NO, NZ, OM, PG, PH, PL, PT, RO, RS, RU, SC, SD, SE, SG, SK, SL, SM, ST, SV, SY, TJ, TM, TN, TR, TT, TZ, UA, UG, US, UZ, VC, VN, ZA, ZM, ZW.

(84) Designated States (unless otherwise indicated, for every kind of regional protection available): ARIPO (BW, GH, GM, KE, LS, MW, MZ, NA, SD, SL, SZ, TZ, UG, ZM, ZW), Eurasian (AM, AZ, BY, KG, KZ, MD, RU, TJ, TM), European (AT, BE, BG, CH, CY, CZ, DE, DK, EE, ES, FI, FR, GB, GR, HR, HU, IE, IS, IT, LT, LU, LV, MC, MK, MT, NL, NO, PL, PT, RO, SE, SI, SK, TR), OAPI (BF, BJ, CF, CG, CI, CM, GA, GN, GQ, GW, ML, MR, NE, SN, TD, TG).

Declarations under Rule 4.17:

- as to applicant's entitlement to apply for and be granted a patent (Rule 4.17(ii))
- as to the applicant's entitlement to claim the priority of the earlier application (Rule 4.17(iii))

[Continued on next page]

(54) Title: VERTICAL COMBINED FEED/EFFLUENT HEAT EXCHANGER WITH VARIABLE BAFFLE ANGLE

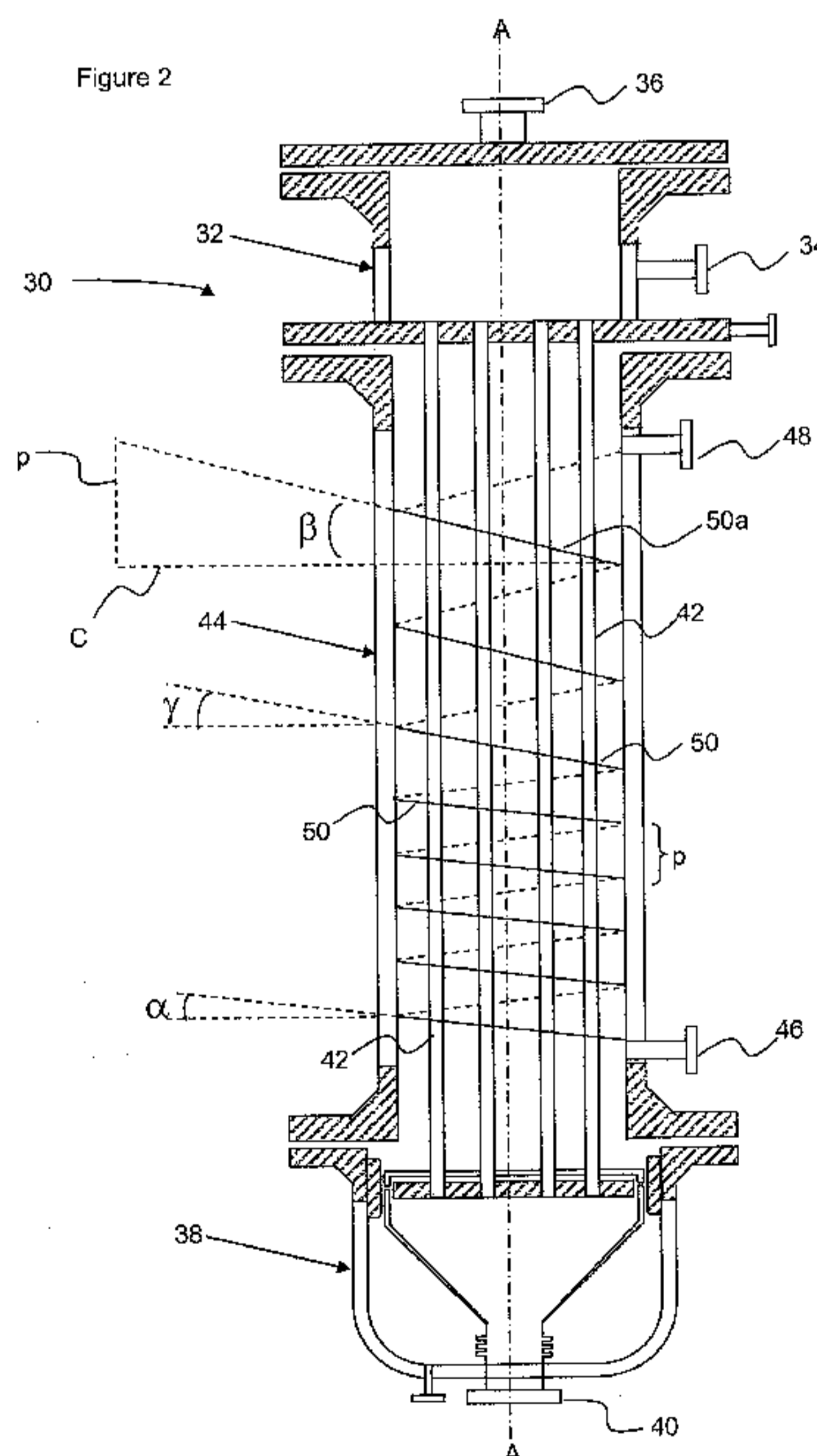
(57) Abstract: A shell and tube heat exchanger, such as a vertical combined feed / effluent heat exchanger (VCFE), including: a shell having a fluid inlet and a fluid outlet; a plurality of baffles mounted in the shell to guide the fluid into a helical flow pattern through the shell; wherein a helix angle α of a baffle proximate the inlet is different than a helix angle β of a baffle proximate the outlet.

WO 2009/148822 A3

WO 2009/148822 A3 

Published:

(88) Date of publication of the international search report:
11 March 2010

- *with international search report (Art. 21(3))*
- *before the expiration of the time limit for amending the claims and to be republished in the event of receipt of amendments (Rule 48.2(h))*

VERTICAL COMBINED FEED/EFFLUENT HEAT EXCHANGER WITH VARIABLE BAFFLE ANGLE

BACKGROUND OF DISCLOSURE

Field of the Disclosure

[0001] Embodiments disclosed herein relate generally to a heat exchanger. More specifically, embodiments disclosed herein relate to a heat exchanger, such as a shell and tube heat exchanger, configured to efficiently process two-phase flow.

Background

[0002] Numerous configurations for heat exchangers are known and used for a variety of applications. One of the widely used configurations, a shell and tube heat exchanger, as illustrated in Figure 1, includes a cylindrical shell 10 housing a bundle of parallel pipes 12, which extend between two end plates 14 so that a first fluid 16 can pass through the pipes 12. Meanwhile, a second fluid 18 flows in and through the space between the two end plates so as to come into contact with the pipes. To provide an improved heat exchange between the two fluids, the flow path of the second fluid 18 is defined by intermediate baffles 20 forming respective passages, which are arranged so that the second fluid flow changes its direction in passing from one passage to the next. The baffles 20, configured as either partial circular segments as shown (partial segmental baffles), or as annular rings and discs, are installed perpendicular to a longitudinal axis 22 of the shell 10 to provide a zigzag flow 24 of the second fluid 18.

[0003] In this arrangement, the second fluid has to sharply change the direction of its flow several times along the length of the shell. This causes a reduction in the dynamic pressure of the second fluid and non-uniform flow velocity thereof, which, in combination, adversely affect the performance of the heat exchanger. For example, a perpendicular position of the baffles relative to the longitudinal axis of the shell results in a relatively inefficient heat transfer rate / pressure drop ratio. Additionally, such baffle arrangements produce flow bypass through baffle-to-shell and pipe-to-baffle clearances, resulting in flow maldistribution, eddies, back-flow, and higher rates of fouling, among other undesired consequences.

[0004] Pressure drop, flow distribution, and heat transfer efficiencies are important variables, especially in the many industrial chemical processes where a vapor phase

reaction is desired between liquid phase feed and product streams. Example processes may include naphtha reforming, naphtha hydrotreating, diesel and kerosene hydrotreating, light hydrocarbon isomerization and metathesis, and many other industrially important processes. Such processes will typically include feed / effluent heat exchange equipment, where the heat required to vaporize the reactor feed stream is recovered by condensation or partial condensation of the reactor effluent. Such heat transfer equipment has historically been arranged as conventional horizontal shell and tube heat exchangers.

[0005] Increasing unit design capacities (economy of scale) requires large volumetric throughput with a resultant impact on the number of shells required to transfer the heat at the limited temperature differentials. However, due to the flow hydraulics issues, *i.e.*, two phase inlet flow, varying composition and molecular weight of the vapor and liquid phases, and variable volumetric flow and pressure drop resulting from phase change, the arrangement of conventional exchanger shells in several parallel and series arrangements is problematic. Symmetrical piping is an unreliable means to effect partitioning of two phase flow. As the vapor molecular weight can be much lower than the associated liquid, especially in hydrotreating services where the vapor is largely composed of hydrogen, the maldistribution of vapor with the liquid entering an exchanger can have a marked impact on the associated boiling curve and, consequently, the mean temperature difference (MTD) of the boiling operation.

[0006] The concept of vertical combined feed / effluent heat exchanger (VCFE) was developed to overcome these drawbacks by integrating large surfaces into a single vertical shell. Such units have been deployed commercially in different configurations, including: tubeside boiling / shellside condensing in single segmental baffle design; tubeside condensing / shellside boiling in single segmental baffle design; tubeside boiling / shellside condensing in helical baffle design; tubeside condensing / shellside boiling in helical baffle design. Helically baffled exchangers are described, for example, in U.S. Patent Nos. 5,832,991, 6,513,583, and 6,827,138.

[0007] On a theoretical basis, shellside boiling is favored to reduce the required surface, as the shellside boiling coefficient is enhanced by the relatively larger volume of the shellside due to mass transport effects. However, fouling

considerations must also be addressed, as the tubeside will normally be easier to clean.

[0008] A drawback of the shellside boiling arrangement is considered at partial load or turndown operation, where the shellside velocities may not be sufficient to prevent phase separation and backflow of the liquid fraction back down to the inlet. Such buildup of heavy liquid fraction at high residence time can result in fouling.

[0009] The main drawback of any tubeside boiling arrangement is that the vapor and liquid fractions must be evenly distributed in each of a multiplicity of tube inlets, in order to maintain the expected boiling characteristics in each tube, and an inexpensive and low pressure drop method to achieve this distribution has not been found.

[0010] Accordingly, there exists a need for heat exchanger and baffle designs for effectively processing two-phase inlet flow in vertical units.

SUMMARY OF THE DISCLOSURE

[0011] In one aspect, embodiments disclosed herein relate to a heat exchanger including: a shell having a fluid inlet and a fluid outlet; a plurality of baffles mounted in the shell to guide the fluid into a helical flow pattern through the shell; wherein a helix angle α of a baffle proximate the inlet is different than a helix angle β of a baffle proximate the outlet.

[0012] In another aspect, embodiments disclosed herein relate to a shell and tube heat exchanger including: a tubeside inlet manifold having a first fluid inlet therein; a tubeside outlet manifold having a first fluid outlet therein; a plurality of tubes extending between the manifolds and in fluid communication therewith; a shell extending between the manifolds and encompassing said tubes, the shell having a second fluid inlet and a second fluid outlet therein; a plurality of baffles mounted in the shell to guide the second fluid into a helical flow pattern through the shell; wherein a helix angle α of a baffle proximate the second fluid inlet is different than a helix angle β of a baffle proximate the second fluid outlet.

[0013] In another aspect, embodiments disclosed herein relate to a process for exchanging heat with a mixed phase fluid, the process including: feeding a mixed phase fluid comprising a vapor and at least one of an entrained liquid and an entrained solid to a heat exchanger, the heat exchanger including: a shell having a fluid inlet, and a fluid outlet; a plurality of baffles mounted in the shell to guide the

fluid into a helical flow pattern through the shell; converting the mixed phase fluid to essentially all vapor; and indirectly exchanging heat between the mixed phase fluid and a heat exchange medium; wherein a helix angle α of a baffle proximate the inlet maintains a velocity of the mixed phase fluid greater than a terminal velocity of the entrained liquid or solid; and wherein a helix angle β of a baffle proximate the outlet is greater than helix angle α of the baffle proximate the inlet.

[0014] Other aspects and advantages will be apparent from the following description and the appended claims.

BRIEF DESCRIPTION OF DRAWINGS

[0015] Figure 1 is a diagrammatic view of flow distribution in a conventional shell and tube heat exchanger.

[0016] Figure 2 is a schematic drawing of a vertical combined feed / effluent heat exchanger with variable heat baffle angle according to embodiments disclosed herein.

DETAILED DESCRIPTION

[0017] In one aspect, embodiments herein relate generally to a heat exchanger. More specifically, embodiments disclosed herein relate to a heat exchanger, such as a shell and tube heat exchanger, configured to efficiently process two-phase flow. Even more specifically, embodiments disclosed herein relate to a heat exchanger having baffles configured to direct a shell side fluid flow in a helical flow pattern, where a helix angle of a baffle proximate the inlet is different than a helix angle of a baffle proximate the outlet.

[0018] Heat exchangers having baffles with a varied helix angle according to embodiments disclosed herein have been found to be useful for shellside fluids undergoing a phase change, such as evaporation, condensation, combustion, and the like. For example, for a two-phase inlet flow, such as a vaporizing liquid-vapor mixture, helix angles proximate to the inlet may be provided to maintain sufficient fluid velocity to avoid phase separation of the vapor and the liquid. The helix angle of baffles proximate the shellside fluid inlet may be close to a position perpendicular to the tubes, thus causing the incoming dense fluid to swirl at a high velocity. As the liquid vaporizes due to heat transfer within the exchanger, the helix angle of the baffles may be further from perpendicular, such as for baffles closer to the shellside

outlet, providing for heat exchange at lower velocities for the less dense vapor and a relatively low pressure drop through the heat exchanger.

[0019] As the phase separation (vapor-liquid, vapor-solid, etc.) is a function of the relative densities, particle and/or droplet size, and the vapor phase velocity, heat exchangers having baffles with a varied helix angle according to embodiments disclosed herein are not subject to shellside phase separation at the same throughput as would occur for a heat exchanger having a constant baffle angle. Accordingly, heat exchangers having baffles with a varied helix angle according to embodiments disclosed herein may be used at significantly reduced throughput levels, thus avoiding the drawbacks typical associated with vertical heat exchangers operating at partial load or turndown operation.

[0020] The helix angle used for the baffles proximate the shellside inlet and outlet may depend on the type of operation. For example, for a fluid mixture including a vapor and a vaporizing liquid or combusting solid, the helix angle of baffles proximate the inlet may be greater than the helix angle of baffles proximate the outlet. In this manner, the velocity of the two-phase mixture may be maintained greater than a transport velocity of the entrained solid or liquid, thus avoiding phase separation. As the fluid vaporizes or the solid combusts, a lower helix angle may be used. In other embodiments, the helix angle may gradually decrease along the longitudinal length of the shell. As another example, for an inlet feed including a vapor to be condensed within the heat exchanger, the helix angle of baffles proximate the shellside inlet may be less than the helix angle of baffles proximate the shellside outlet, thus increasing the velocity of the mixture during the condensing operation.

[0021] Referring now to Figure 2, a schematic drawing of a vertical combined feed / effluent heat exchanger having baffles with varied helix angles according to embodiments disclosed herein is illustrated. Heat exchanger 30 may include a tubeside inlet manifold 32 having a fluid inlet 34 therein. Tubeside inlet manifold 32 may also have a vent 36 disposed therein. Heat exchanger 30 may also include a tubeside outlet manifold 38 having a fluid outlet 40 therein. A plurality of tubes 42 may extend between the tubeside inlet manifold 32 and outlet manifold 38, allowing for transport of a fluid from the inlet manifold 32 to outlet manifold 38 through

tubes 42. Figure 2 illustrates the use of four tubes, however it is to be understood that any number of tubes may be used.

[0022] Shell 44 extends between inlet and outlet manifolds 32, 38, encompassing tubes 42, and includes a shellside fluid inlet 46 and a shellside fluid outlet 48. Located within shell 44 is a plurality of baffles 50. Baffles 50 may include, for example, helical baffles as described in U.S. Patent Nos. 5,832,991, 6,513,583, and 6,827,138, the entire contents of each which are incorporated herein by reference. Baffles 50 may include tube orifices (not shown) to allow tubes 42 to pass through baffles 50, and to allow baffles 50 to retain tubes 42 in an aligned and desired location. Baffles 50 may act to guide the shellside fluid into a helical flow pattern through the shell.

[0023] Baffles 50 are arranged within heat exchanger 30 such that baffles 50 proximate the shellside inlet 46 have a different helix angle than baffles 50 proximate shellside outlet 48. The helix angle of the baffles may be determined, for example, by “unwinding” the helix, forming a two-dimensional representation of the helical pattern. As illustrated in Figure 2 for baffle 50a, the helix angle would then be determined as the arctangent of the shell circumference C divided by the pitch p (longitudinal distance traversed by a baffle arc extending 360°). The pitch is equal to:

$$p = C \cdot \tan(\beta);$$

where β is the helix angle. Therefore, helix angle β is equal to $\arctan(p/C)$.

[0024] As illustrated, heat exchanger 30 is equipped with helical baffles 50 oriented vertically. Baffles 50 proximate shellside inlet 46 may have a helix angle α . Baffles 50 proximate shellside outlet 48 may have a helix angle β with respect to longitudinal axis A-A of shell 44. Thus, for example, for a vaporizing two-phase shellside feed stream entering via shellside inlet 46, the baffles 50 proximate the inlet 46 are arranged at a low helix angle α ; *i.e.*, closer to perpendicular with respect to axis A-A than baffles 50 proximate shellside outlet 48, having a helix angle β , where heat exchange is expected to be gas/gas at a higher shellside volumetric flow, such as due to evaporation, combustion, and / or heating of the shellside fluid. A low helix angle α may thus cause the two-phase inlet flow to swirl in a helical path at a velocity sufficient to avoid phase separation. Because the shellside fluid is gas/gas proximate outlet 48, a helix angle β greater than helix angle α may be used,

thus resulting in a lower pressure drop than where angle α is used along the entire length of shell 44.

[0025] In some embodiments, baffles intermediate shellside fluid inlet 46 and outlet 48 may have a helix angle γ intermediate that of helix angles α , β . For example, the helix angles of baffles 50 may gradually increase or decrease from inlet 46 to outlet 48, depending on the type of service (*e.g.*, condensing, evaporating, etc.). In other embodiments, the helix angles for baffles 50 may undergo one or more step changes.

[0026] As mentioned above, heat exchangers having baffles with a varied helix angle according to embodiments disclosed herein may be useful where two-phase fluid flow is expected. Lower helix angles where two-phase flow is expected may provide for a higher vapor phase velocity, avoiding shellside phase separation. The helix angles of baffles proximate the inlet and outlet may be a function of the relative densities of the two phases, particle or droplet size of the solids and/or liquids (related to the transport velocity of the particles or droplets), typical feed rates, partial load or turndown feed rates, temperature rise of the shellside fluid and other variables as known to those skilled in the art.

[0027] The vertical combined feed/effluent heat exchangers described herein may use baffles having an approximate helix angle within the range from about 5° to 45° , inclusive. Any combination of baffle angles α , β and γ (if present) which creates an appropriate helix angle may be used in accordance with embodiments disclosed herein.

[0028] For example, in some embodiments, helix angle α may be within the range from about 5° to about 45° ; within the range from about 5° to about 35° in other embodiments; and from about 5° to about 25° in yet other embodiments.

[0029] In other embodiments, baffle angle β may be within the range from 15° to about 45° ; within the range from about 25° to about 45° in other embodiments; and from about 35° to about 45° in yet other embodiments.

[0030] Heat exchangers according to embodiments disclosed herein may advantageously be used with shellside fluids having two or more phases. Advantageously, heat exchangers according to embodiments disclosed herein may provide for a shellside fluid flow velocity to minimize or avoid phase-separation of fluids passing through the shell, such as by having baffles with a small helix angle where two-phase flow is expected. Additionally, use of larger helix angles where

single phase flow is expected may advantageously provide for a lower pressure drop than where a constant helix angle is used throughout the shell. Thus, compared to traditional heat exchangers having baffles with a constant helix angle, heat exchangers according to embodiments disclosed herein may maintain two-phase fluid flow even at significantly reduced throughput levels, thus advantageously allowing for a broader throughput range.

[0031] While the disclosure includes a limited number of embodiments, those skilled in the art, having benefit of this disclosure, will appreciate that other embodiments may be devised which do not depart from the scope of the present disclosure. Accordingly, the scope should be limited only by the attached claims.

CLAIMS

What is claimed:

1. A heat exchanger comprising:
 - a shell having a fluid inlet and a fluid outlet;
 - a plurality of baffles mounted in the shell to guide the fluid into a helical flow pattern through the shell;
 - wherein a helix angle α of a baffle proximate the inlet is different than a helix angle β of a baffle proximate the outlet.
2. The heat exchanger of claim 1, wherein helix angle β is less than helix angle α .
3. The heat exchanger of claim 1, wherein helix angle α is less than helix angle β .
4. The heat exchanger of claim 1, wherein the helix angle of the plurality of baffles decreases from the fluid inlet to the fluid outlet.
5. The heat exchanger of claim 1, wherein the helix angle of the plurality of baffles increases from the fluid inlet to the fluid outlet.
6. The heat exchanger of claim 1, wherein a baffle intermediate the baffle proximate the inlet and the baffle proximate the outlet has a helix angle γ intermediate helix angles α and β .
7. The heat exchanger of claim 1, wherein helix angle α is less than helix angle β , and wherein helix angle α is within the range from about 5° to about 35° and wherein helix angle β is within the range from about 15° to about 45° .
8. The heat exchanger of claim 7, wherein helix angle α is within the range from about 5° to about 25° .
9. A shell and tube heat exchanger comprising:
 - an tubeside inlet manifold having a first fluid inlet therein;
 - an tubeside outlet manifold having a first fluid outlet therein;
 - a plurality of tubes extending between the manifolds and in fluid communication therewith;
 - a shell extending between the manifolds and encompassing said tubes, the shell having a second fluid inlet and a second fluid outlet therein;
 - a plurality of baffles mounted in the shell to guide the second fluid into a helical flow pattern through the shell;
 - wherein a helix angle α of a baffle proximate the second fluid inlet is different than a helix angle β of a baffle proximate the second fluid outlet.
10. The heat exchanger of claim 9, wherein helix angle β is less than helix angle α .

11. The heat exchanger of claim 9, wherein helix angle α is less than helix angle β .
12. The heat exchanger of claim 9, wherein the helix angle of the plurality of baffles decreases from the fluid inlet to the fluid outlet.
13. The heat exchanger of claim 9, wherein the helix angle of the plurality of baffles increases from the fluid inlet to the fluid outlet.
14. The heat exchanger of claim 9, wherein a baffle intermediate the baffle proximate the inlet and the baffle proximate the outlet has a helix angle γ intermediate helix angles α and β .
15. The heat exchanger of claim 9, wherein helix angle α is less than helix angle β , and wherein helix angle α is within the range from about 5° to about 35° and wherein helix angle β is within the range from about 15° to about 45° .
16. The heat exchanger of claim 15, wherein helix angle α is within the range from about 5° to about 25° .
17. A process for exchanging heat with a mixed phase fluid, the process comprising:
 - feeding a mixed phase fluid comprising a vapor and at least one of an entrained liquid and an entrained solid to a heat exchanger, the heat exchanger comprising:
 - a shell having a fluid inlet, and a fluid outlet;
 - a plurality of baffles mounted in the shell to guide the fluid into a helical flow pattern through the shell;
 - converting the mixed phase fluid to essentially all vapor; and
 - indirectly exchanging heat between the mixed phase fluid and a heat exchange medium;
 - wherein a helix angle α of a baffle proximate the inlet maintains a velocity of the mixed phase fluid greater than a terminal velocity of the entrained liquid or solid; and
 - wherein a helix angle β of a baffle proximate the outlet is greater than helix angle α of the baffle proximate the inlet.
18. The process of claim 17, wherein the converting comprises evaporating the entrained liquid.
19. The process of claim 17, wherein the converting comprises combusting the entrained solid.
20. The process of claim 17, wherein helix angle α is within the range from about 5° to about 35° and wherein helix angle β is within the range from about 15° to about 45° .

1/2

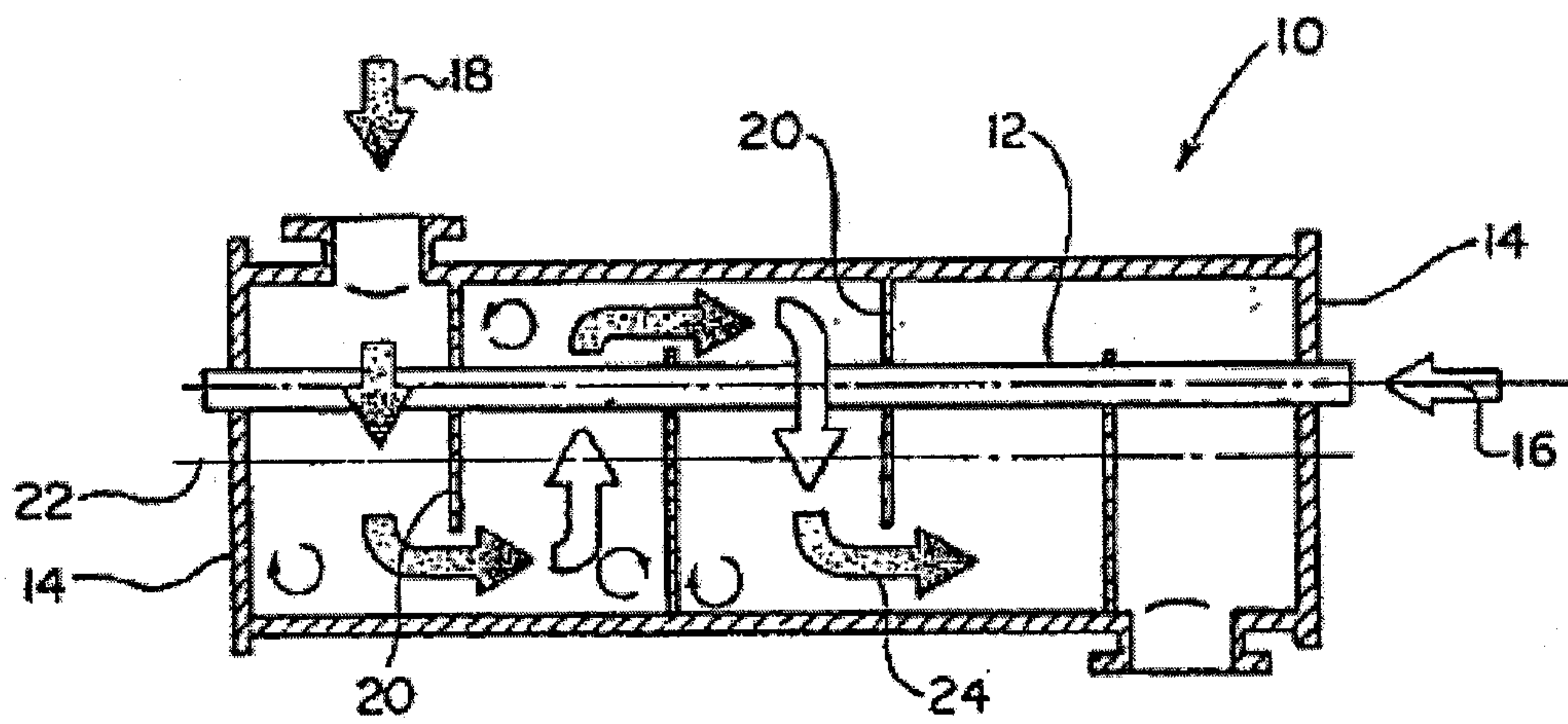

Figure 1 (prior art)

2/2

Figure 2

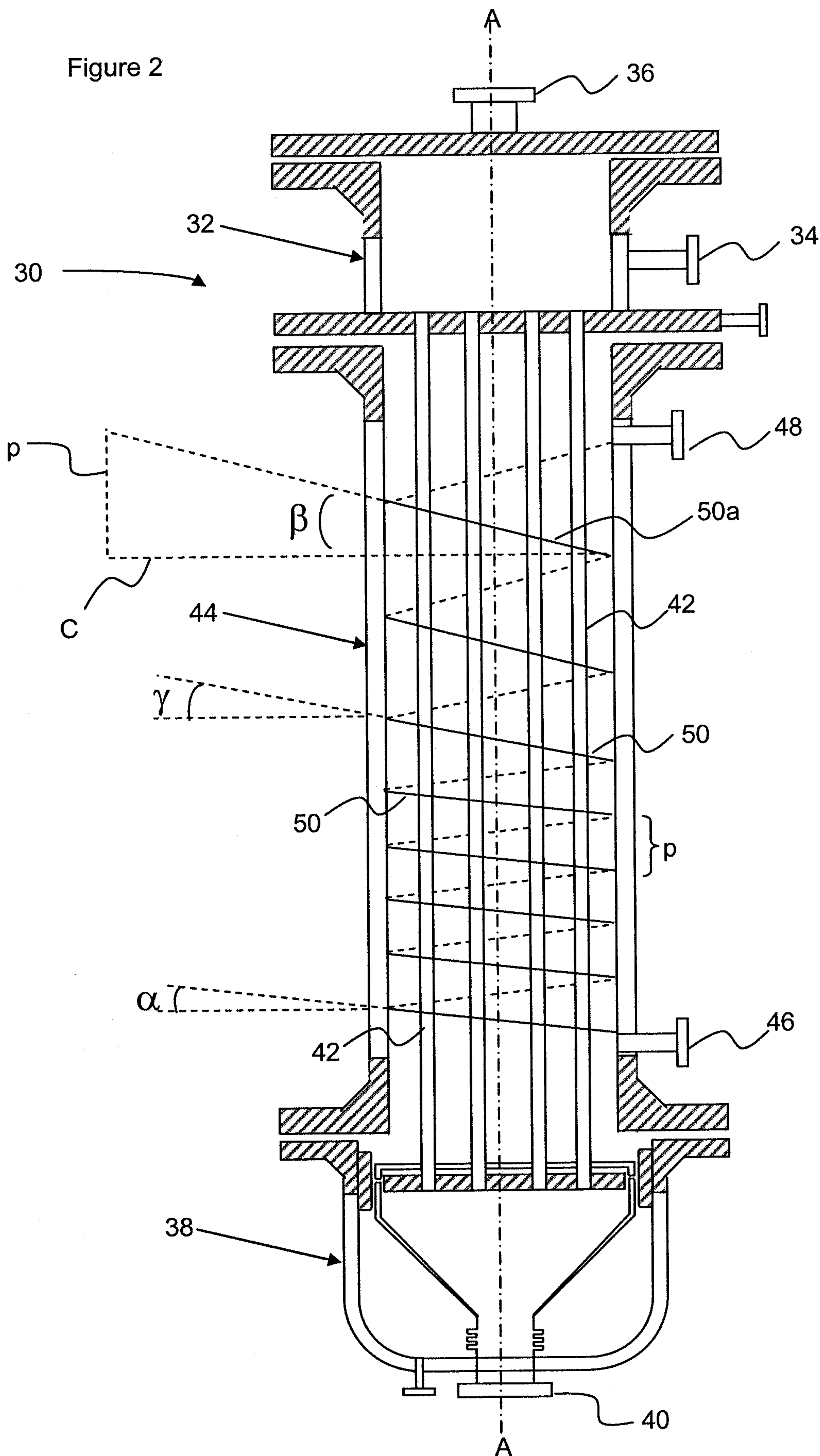

Figure 2

