

(19) World Intellectual Property Organization  
International Bureau



(43) International Publication Date  
16 August 2007 (16.08.2007)

PCT

(10) International Publication Number  
**WO 2007/092637 A2**

- (51) **International Patent Classification:**  
A61M 5/142 (2006.01) A61M 5/168 (2006.01)  
A61M 5/145 (2006.01)
- (21) **International Application Number:**  
PCT/US2007/003634
- (22) **International Filing Date:** 9 February 2007 (09.02.2007)
- (25) **Filing Language:** English
- (26) **Publication Language:** English
- (30) **Priority Data:**  
60/772,313 9 February 2006 (09.02.2006) US  
60/789,243 5 April 2006 (05.04.2006) US  
60/793,188 19 April 2006 (19.04.2006) US
- (71) **Applicant (for all designated States except US):** DEKA PRODUCTS LIMITED PARTNERSHIP [US/US]; 340 Commercial Street, Manchester, NH 03101-1108 (US).
- (72) **Inventors; and**
- (75) **Inventors/Applicants (for US only):** BEAVIS, Russell, H [US/US]; 3 Brewster Street, Merrimack, NH 03054 (US). KAMEN, Dean [US/US]; 15 Westwind Drive, Bedford, NH 03110 (US). GRAY, Larry, B. [US/US]; 19 Iris Drive, Merrimack, NH 03054 (US).

- (74) **Agents:** CARTER, Barbara, J. et al.; Bromberg & Sunstein Llp, 125 Summer Street, Boston, MA 02110-1618 (US).
- (81) **Designated States (unless otherwise indicated, for every kind of national protection available):** AE, AG, AL, AM, AT, AU, AZ, BA, BB, BG, BR, BW, BY, BZ, CA, CH, CN, CO, CR, CU, CZ, DE, DK, DM, DZ, EC, EE, EG, ES, FI, GB, GD, GE, GH, GM, GT, HN, HR, HU, ID, IL, IN, IS, JP, KE, KG, KM, KN, KP, KR, KZ, LA, LC, LK, LR, LS, LT, LU, LV, LY, MA, MD, MG, MK, MN, MW, MX, MY, MZ, NA, NG, NI, NO, NZ, OM, PG, PH, PL, PT, RO, RS, RU, SC, SD, SE, SG, SK, SL, SM, SV, SY, TJ, TM, TN, TR, TT, TZ, UA, UG, US, UZ, VC, VN, ZA, ZM, ZW.
- (84) **Designated States (unless otherwise indicated, for every kind of regional protection available):** ARIPO (BW, GH, GM, KE, LS, MW, MZ, NA, SD, SL, SZ, TZ, UG, ZM, ZW), Eurasian (AM, AZ, BY, KG, KZ, MD, RU, TJ, TM), European (AT, BE, BG, CH, CY, CZ, DE, DK, EE, ES, FI, FR, GB, GR, HU, IE, IS, IT, LT, LU, LV, MC, NL, PL, PT, RO, SE, SI, SK, TR), OAPI (BF, BJ, CF, CG, CI, CM, GA, GN, GQ, GW, ML, MR, NE, SN, TD, TG).

**Published:**  
— without international search report and to be republished upon receipt of that report

[Continued on next page]

(54) **Title:** PATCH-SIZED FLUID DELIVERY SYSTEMS AND METHODS

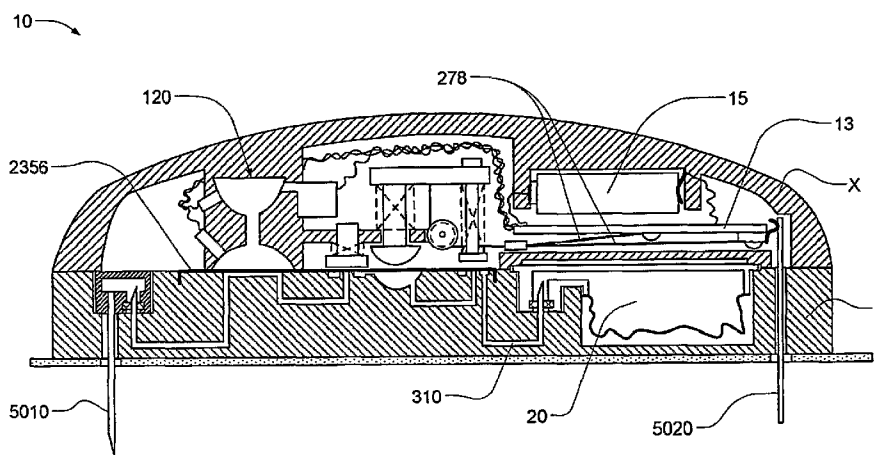

(57) **Abstract:** A patch-sized fluid delivery device may include a reusable portion and a disposable portion. The disposable portion may include components that come into contact with the fluid, while the reusable portion may include only components that do not come into contact with the fluid. Redundant systems, such as redundant controllers, power sources, motor actuators, and alarms, may be provided. Alternatively or additionally, certain components can be multi-functional, such as microphones and loudspeakers that may be used for both acoustic volume sensing and for other functions and a coil that may be used as both an inductive coupler for a battery recharger and an antenna for a wireless transceiver. Various types of network interfaces may be provided in order to allow for remote control and monitoring of the device.

WO 2007/092637 A2



---

*For two-letter codes and other abbreviations, refer to the "Guidance Notes on Codes and Abbreviations" appearing at the beginning of each regular issue of the PCT Gazette.*

### **Background**

Many potentially valuable medicines or compounds, including biologicals, are not orally active due to poor absorption, hepatic metabolism or other pharmacokinetic factors. Additionally, some therapeutic compounds, although they can be orally absorbed, are sometimes required to be administered so often it is difficult for a patient to maintain the desired schedule. In these cases, parenteral delivery is often employed or could be employed.

Effective parenteral routes of drug delivery, as well as other fluids and compounds, such as subcutaneous injection, intramuscular injection, and intravenous (IV) administration include puncture of the skin with a needle or stylet. Insulin is an example of a therapeutic fluid that is self-injected by millions of diabetic patients. Users of parenterally delivered drugs would benefit from a wearable device that would automatically deliver needed drugs/compounds over a period of time.

To this end, there have been efforts to design portable devices for the controlled release of therapeutics. Such devices are known to have a reservoir such as a cartridge, syringe, or bag, and to be electronically controlled. These devices suffer from a number of drawbacks including the malfunction rate. Reducing the size, weight and cost of these devices is also an ongoing challenge.

### **Summary of the Invention**

In various embodiments of the present invention, a patch-sized housing for a fluid delivery system may include a reusable portion and a disposable portion that is removably engageable with the reusable portion. In terms of fluid delivery management, the disposable portion generally includes all of the fluid management components that come into contact with the fluid (e.g., a fluid path having various valve, pump, and/or dispensing regions bounded by flexible membrane material), while the reusable portion generally includes fluid management components that do not come into contact with the fluid (e.g., various valve actuators, pump actuators, and sensors that interface with the fluid path through the flexible membrane material). The reusable portion generally also

includes most, if not all, of the components that would be considered reusable or non-disposable, such as, for example, a controller, an active mechanical assembly including a pump with valve and/or pump actuators and pump motor(s), one or more sensors (e.g., a fluid flow/volume sensor, a temperature sensor), one or more electrical power sources (e.g., a rechargeable battery) and related circuitry (e.g., a battery recharging circuit and a coil for inductively coupling the battery charging circuit to an external power supply), a network interface (e.g., a wireless transceiver with antenna, a wireline interface such as USB), and user interface components (e.g., a pushbutton control). The disposable portion generally includes single-use or limited-use components relating to fluid management, but may also include an integral fluid reservoir and other components, such as a backup power source, a small processor (e.g., to continue certain device operations in the event of a failure, to generate an alarm in the event of a failure, or to provide status information to the reusable portion), and/or an alarm output. The disposable portion may also include, or be configured to support, so-called "sharps" components (e.g., a cannula with cannula delivery needle and an analyte sensor) and an assembly for inserting the sharps into a patient (e.g., a cartridge that holds the sharps and an actuator for inserting the sharps). The substrate and the flexible membrane material of the disposable portion may constitute a fluidic assembly that is configured to fit within a disposable base.

In certain embodiments, the disposable portion includes a substrate having flexible membrane material thereon and incorporating therein a fluid channel, the fluid channel being part of a fluid path in the disposable portion from a reservoir port to a cannula port and including a series of regions exposed to the flexible membrane material, at least one of such regions being a valve region. The reusable portion includes a control assembly having an active mechanical assembly that interacts mechanically with the regions through the membrane material in such a manner as to achieve pumping of fluid along the fluid path, the active mechanical assembly including a valve actuator that operates on the valve region. The disposable portion may also include a pump region, and the active mechanical assembly may include a pump actuator that operates on the pump region. The series of regions may be exposed to a single flexible membrane of the flexible membrane material.

The active mechanical assembly generally includes a motor for operation of the valve actuator and/or the pump actuator under control of the control assembly. The valve actuator and the pump actuator may be interconnected by a plate for coordinated operation of the valve actuator and the pump actuator. The motor may include one or more shape-memory actuators. The motor may include a heater for operating the shape-memory actuator(s). Alternatively, the shape-memory actuator(s) may be operated through changes in electrical current passed through at least a portion of the shape-memory actuator. Multiple shape-memory actuators may be used for redundancy and/or to provide different modes of operation (e.g., a normal pumping mode and a high-powered pumping mode). The motor may include multiple shape-memory actuators of different lengths or gauges.

The disposable portion may include an integral fluid reservoir or may include a reservoir interface for coupling with a fluid reservoir. The reservoir interface may include a cannulated needle for introduction into the fluid reservoir so as to provide fluid communication between the fluid reservoir and the fluid path or may include a septum for penetration by a fluid reservoir cannulated needle so as to provide fluid communication between the fluid reservoir and the fluid path. At least one of the reusable portion and the disposable portion may include a recess for receiving the fluid reservoir. The fluid reservoir and the corresponding recess may be eccentrically shaped and/or keyed so as to prevent incorrect orientation of the fluid reservoir within the housing.

The disposable portion may be configured to support a cannulus in fluid communication with the fluid path and an analyte sensor in communication with the control assembly. Interconnection between the control assembly and the analyte sensor may be established upon engagement of the reusable portion and the disposable portion. In this regard, the control assembly may include an analyte sensor interface for direct interconnection with the analyte sensor. Alternatively, the communication path between the control assembly and the analyte sensor may include a portion of the disposable unit or may be wireless.

One challenge in such a patch-sized device is fitting all of the components into the reusable and disposable portions while also providing sufficient space for a fluid reservoir that holds a substantial amount of fluid and a pump that is capable of delivering

a relatively large volume of fluid per day. Therefore, in certain embodiments of the present invention, elongated components (e.g., strips of shape-memory material and/or portions of the fluid path) may be “folded” within the housing, for example, using coil or serpentine shaped paths. One or more pulleys may be used to fit a length of shape-memory material into the housing.

Because the fluid delivery system may be used to deliver life-critical therapeutic fluids to a patient, it may be advantageous to have so-called “fail safe” operation so that a device failure will not allow fluid to be delivered to the patient at an unsafe flow rate. Therefore, certain embodiments of the present invention include a finite fluid impedance downstream of the regions so as to prevent delivery of fluid at an unsafe flow rate. The fluid impedance may be passive and/or may include a conduit. The conduit may be integral to the disposable unit (e.g., an in-molded channel) or may be a separate component, such as tubing. The conduit may have a specified minimum inside diameter (e.g., to reduce the likelihood of blockage) such that it may be necessary or desirable for the conduit to be elongated in order to achieve a desired impedance. In order to fit such an elongated conduit within the housing, the conduit may be tortuous (e.g., coiled or serpentine). For further fail safe operation, the device may operate with a non-pressurized fluid reservoir so that failure or shut-down of the pump effectively prevents further delivery of fluid to the patient.

Particularly in the context of delivering therapeutic fluid to a patient, it may be necessary or desirable to very precisely measure and control the volume of fluid delivered to the patient over time. Thus, in various embodiments of the present invention, the disposable portion may include in the fluid path a dispensing chamber bounded by flexible membrane material, and the reusable portion may include a fluid sensor (e.g., an acoustic volume sensor) in communication with the dispensing chamber for measuring fluid flow through the dispensing chamber. The fluid path may include a finite fluid impedance (e.g., of the types described above) downstream of the dispensing chamber so that the dispensing chamber membrane expands in response to the pumping of fluid. A resilient dispensing spring may be provided (e.g., in the reusable portion or in the dispensing chamber membrane itself) to facilitate contraction of the dispensing chamber membrane.

In order to reduce the number of components in the device, it may be advantageous to utilize certain components for more than one function. For example, in embodiments that include an acoustic volume sensor having a loudspeaker and/or a microphone, the loudspeaker may be used to produce audible alarms, while the microphone may be used to monitor operation of mechanical components such as a fluid pump (e.g., by “listening” for sounds and vibrations generated by the mechanical components). Also, in embodiments that include both a battery recharging circuit and a wireless transceiver, a single coil (e.g., a solenoid) may be included for both inductively coupling the battery recharging circuit with an external power source and conveying radio frequency signals to and from the wireless transceiver. Also, a user input (e.g., a pushbutton control) may be included to allow manual control of various functions, such as power on/off and manual actuation of the pump for such things as priming, air purging, and emergency delivery of a quantity of fluid.

It may also be advantageous to eliminate or minimize the number of user interface components supported by the housing. User interface components such as a LCD screen and a keyboard can add cost, size, weight, and complexity to the device as well as consume valuable battery power. Therefore, rather than including a full-featured user interface in the device, the user interface may be provided exclusively or partially through a remote controller that communicates with the device through a network interface. The network interface may include a wireless interface (e.g., Bluetooth, infrared) or may include a wireline interface (e.g., USB port). The device may include certain types of user inputs, such as a pushbutton control to allow for manual actuation of the pump (e.g., for priming, air-purging, or delivering an emergency dose of fluid).

Particularly in a medical context, it may be necessary or desirable to include certain redundant systems to reduce the likelihood of complete device failure. For example, a pump motor may include multiple actuators (e.g., multiple strands of shape-memory material) in order to maintain pump operation in the event one of the actuators fails, a backup electrical power source (e.g., a battery or supercapacitor) may be included in order to provide electrical power in the event of a failure of a primary power source (e.g., a rechargeable battery), and multiple alarm outputs (e.g., audible, visual, tactile, and/or wireless alarm outputs) may be provided so that status information (e.g., low

battery level, low fluid level, occlusion or air bubble detected, etc.) can be conveyed to the patient in multiple modes. Also, a backup processor or controller may be included (e.g., in the disposable portion) to either continue device operation in the event of a failure of a primary controller (e.g., in the reusable portion) or at least generate an alarm to indicate that a failure has occurred.

It may also be advantageous for the reusable portion to take certain remedial actions (e.g., prevent or terminate operation of the device, change a mode of operation of the pump, and/or generate an alarm) in certain situations. Alarms may include audible alarms (e.g., via a speaker or buzzer), visual alarms (e.g., via an LED), tactile alarms (e.g., via a vibrating mechanism), and/or wireless alarms (e.g., transmitting an alarm signal to a remote controller or caretaker), to name but a few. Alarm components may be included in the reusable portion and/or the disposable portion and may be actuated by a controller in the reusable portion and/or a controller in the disposable portion. Alarms may be generated using multiple mechanisms simultaneously or concurrently.

For example, the reusable portion may be configured to take remedial actions upon detection of a fault condition. Fault conditions may include such things as a low power level, a low fluid level, an abnormal temperature level, a problem with a primary or backup power supply, detection of an occlusion, detection of an air bubble, detection of a fluid leak, detection of abnormal vibration from the pump, and detection of lack of vibration from the pump, to name but a few.

Furthermore, the reusable portion may be configured to take remedial actions upon detection of a problem with any of the disposables, which may include the disposable portion itself and other types of disposable components that may be used in or with the disposable portion, such as, for example, a fluid reservoir and a sharps cartridge (such components may be integral with the disposable portion or installed into the disposable portion in various embodiments). For example, upon engagement of the disposable portion with the reusable portion, the reusable portion may read or otherwise obtain information about the disposables such as, for example, manufacturer, model number, serial number, shelf life, maximum exposure, maximum operation temperature, expiration date, and safe dispensing limits for the therapeutic, to name but a few. The reusable portion may obtain such information, for example, through communication with



a processor in the disposable portion, a bar code reader, and/or RFID technology, to name but a few. If the reusable portion detects a problem with the disposables (e.g., invalid model number for use with the reusable portion or expiration date of the fluid has passed), then the reusable portion may prevent or terminate operation of the device and generate an appropriate alarm.

The reusable portion may be configured to generate alarms to indicate an operational condition. Operational conditions may include such things as a power on condition, proper operation of the control assembly, and proper delivery of fluid within a predetermined set of parameters. In certain embodiments, an alarm may be generated upon an attempted manual actuation of the pump in order to alert the patient or caretaker of the attempt and solicit a confirmation before proceeding with pump actuation.

The reusable portion may be configured to generate alarms to test and report on patient responsiveness. For example, the reusable portion may be configured to test patient responsiveness by generating an alarm (e.g., an audible and/or tactile alarm) and awaiting a response from the patient (e.g., actuation of a pushbutton control). Such a test may be performed at various times (e.g., every five minutes) or upon detection of a condition such as an abnormal analyte level monitored via an analyte sensor or an abnormal body temperature monitored via a temperature sensor. If the patient does not provide an appropriate response within a predetermined amount of time, the reusable portion may send an alarm to a remote controller or caretaker. Such testing and reporting might be particularly valuable for patients who could become unconscious or incapacitated, either from a device malfunction or otherwise.

In order to deliver fluid to a patient, the patch-sized device is typically secured against the skin, for example, using straps or adhesive. In certain exemplary embodiments, the disposable portion may be placed against the skin before or after insertion of sharps into the patient's skin and before or after installation of the fluid reservoir (if necessary), and the reusable portion may then be engaged with the disposable portion in order to place the device into an operational configuration. Alternatively, the entire device may be assembled prior to placement against the skin. In any case, one or more pads may be situated between the underside of the disposable portion and the patient's skin so as to provide separation between the disposable portion

and the patient's skin. The pad(s) may provide, or may be configured to provide, air flow to a portion of the patient's skin covered by the disposable portion when placed on the patient (e.g., air flow may be provided by passageways through the pad, passageways between pads, and/or construction of the at least one pad from a porous material). The pad(s) may be provided with an adhesive for securing the device to the patient. Alternatively, the device may be secured to the patient using tethers that are coupled to the device and adhesive members for securing the tethers to a patient's skin.

It should be noted that the reusable portion, the disposable portion, the fluid reservoir, and the sharps cartridge may be considered as separate embodiments of the invention. It is envisioned that these components will be manufactured separately and will be sold separately or packaged in different configurations. Thus, for example, one type of kit might include a reusable unit packaged together with one or more disposable units. Another type of kit might include a disposable unit and a sharps cartridge. Other types of kits are of course possible.

It should also be noted that patches with different combinations of the described features may be considered as separate embodiments of the invention. Thus, for example, a patch with a pump and an acoustic volume sensor, a patch with redundant actuators, a patch with redundant power sources, a patch with redundant alarms, a patch with redundant controllers, a patch that is configured to take remedial actions upon detection of a problem with the disposables, a patch that is configured to test and report patient responsiveness, and others may be considered as separate embodiments of the invention.

Thus, in accordance with one aspect of the invention there is provided apparatus comprising a patch-sized housing including a reusable portion and a disposable portion that is removably engageable with the reusable portion. The disposable portion includes a substrate having flexible membrane material thereon and incorporating therein a fluid channel, the fluid channel being part of a fluid path in the disposable portion from a reservoir port to a cannula port and including a series of regions exposed to the flexible membrane material, at least one of such regions being a valve region. The reusable portion includes a control assembly having an active mechanical assembly that interacts mechanically with the regions through the membrane material in such a manner as to

achieve pumping of fluid along the fluid path, the active mechanical assembly including a valve actuator operating on the valve region.

In various alternative embodiments, the series of regions may be exposed to a single flexible membrane of the flexible membrane material.

5 In other alternative embodiments, the fluid path may include a fluid impedance (e.g., a passive fluid impedance and/or a tortuous conduit, which may be an integral part of the fluid channel, may comprise coiled tubing, may have a serpentine shape, may have a length greater than a largest dimension of the housing, may have an effective internal diameter or length selected to provide a predetermined impedance based on at least one  
10 of a viscosity and a density of the fluid, or may have an internal diameter sufficiently large to prevent occlusion due to flow of a therapeutic liquid through the conduit) downstream of the regions so as to prevent pumping of fluid along the path at an unsafe flow rate.

In still other alternative embodiments, the substrate may include a dispensing  
15 chamber formed in the fluid channel of the substrate, such chamber bounded by flexible membrane material forming a dispensing chamber membrane. The fluid path may include a finite fluid impedance downstream of the dispensing chamber, the fluid impedance sufficiently high so as to cause the expansion of the dispensing chamber membrane in response to the pumping of fluid induced by the active mechanical  
20 assembly. The control assembly may include at least a first pump mode in which the dispensing chamber is permitted to substantially empty between pump strokes and a second pump mode in which the dispensing chamber is not permitted to fully empty between pump strokes. The reusable portion or the dispensing chamber membrane may include a resilient dispensing spring (e.g., a spiral shape, a fan shape, or having multiple  
25 helical grooves) positioned atop the dispensing chamber membrane to facilitate contraction of the dispensing chamber membrane. The control assembly may include a fluid sensor (e.g., an acoustic volume sensor) in communication with the dispensing chamber for measuring fluid flow through the dispensing chamber. An acoustic volume sensor may include a loudspeaker that can be used by the control assembly for both  
30 acoustic volume sensing and audible alarm generation. An acoustic volume sensor may

include a microphone that can be used by the control assembly for both acoustic volume sensing and monitoring pump operation.

In still other alternative embodiments, the disposable portion may include a pump region, and wherein the active mechanical assembly further includes a pump actuator  
5 operating on the pump region. The active mechanical assembly may include a motor for operation of at least one of the valve actuator and the pump actuator under control of the control assembly. The active mechanical assembly may include a plate coupled to the valve actuator, the pump actuator, and the motor for coordinated operation of the valve  
10 actuator and the pump actuator. The valve region may be positioned between the reservoir port and the pump region and operation of the valve actuator and the pump actuator may be coordinated so as to prevent backflow of fluid toward the reservoir port. The motor may include one or more shape-memory actuators and may include at least one pulley for folding a shape-memory actuator to fit within the reusable portion. The shape-memory actuator may be operated through changes in heat, and the motor may  
15 include a heater for operating the shape-memory actuator. Alternatively, the shape-memory actuator may be operated through changes in electrical current passed through at least a portion of the shape-memory actuator. A shape-memory actuator may be electrically coupled so as to provide a plurality of electrical paths of different lengths through the shape-memory actuator for providing different actuation forces or stroke  
20 lengths, and a shorter electrical path may be used during normal operation of a pump and a longer electrical path may be used during priming and air-purging of the pump. The motor may include a plurality of shape-memory actuators. The plurality of shape-memory actuators may be of the same length/gauge or may be of different lengths/gauges, and may be used for providing redundant operation of the active  
25 mechanical assembly and/or for providing different actuation forces or stroke lengths (e.g., a shorter shape-memory actuator used during normal operation of a pump and a longer shape-memory actuator used during priming and air-purging of the pump).

In still further alternative embodiments, the substrate and the flexible membrane material of the disposable portion may constitute a fluidic assembly, and the disposable  
30 portion may further include a disposable base into which the fluidic assembly fits. An adhesive pad may be coupled to a bottom of the disposable base.

In still other alternative embodiments, the reservoir port may include a reservoir interface for coupling with a fluid reservoir. The reservoir interface may include a cannulated needle for introduction into the fluid reservoir so as to provide fluid communication between the fluid reservoir and the fluid path or may include a septum for penetration by a fluid reservoir cannulated needle so as to provide fluid communication between the fluid reservoir and the fluid path. At least one of the reusable portion and the disposable portion may include a recess for receiving a fluid reservoir. The fluid reservoir may be eccentrically shaped so as to deter incorrect orientation of the fluid reservoir within the housing.

In yet more alternative embodiments, the reusable portion and the disposable portion may include a latching mechanism for permitting selective engagement and disengagement of the reusable and disposable portions. The reusable portion may include at least one latch actuator for permitting selective coupling and decoupling of the reusable and disposable portions.

In other alternative embodiments, the control assembly may include an electrical power source for providing electrical power to electronics in at least one of the reusable portion and the disposable portion. The electrical power source may include a rechargeable battery. The control assembly further may further include a battery recharging circuit for recharging a battery, and may also include a coil for inductively coupling the battery recharging circuit with an external power source for recharging the rechargeable battery. The control assembly may also include a backup electrical power source, such as a battery or a supercapacitor. Additionally or alternatively, the disposable portion may include an electrical power source, such as a battery or supercapacitor, for providing electrical power to electronics in at least one of the reusable portion and the disposable portion.

In still other alternative embodiments, the control assembly may include a network interface, such as a wireless transceiver and/or a wireline interface, for communication with a remote controller. With regard to a wireless transceiver, the control assembly may include a coil coupled to the wireless transceiver for conveying radio frequency signals to and from the wireless transceiver. The control assembly may also include a battery recharging circuit for recharging a rechargeable battery, wherein

the coil is further coupled to the battery recharging circuit for inductively coupling the battery recharging circuit with an external power source. The control assembly may receive configuration information from the remote controller and send status information to the remote controller via the network interface.

5           In yet other alternative embodiments, various types of input/output devices and sensors, such as an audible output (e.g., a speaker), a visual output (e.g., an LED), a tactile output (e.g., a vibrating mechanism), a wireless output, an audio input (e.g., a microphone), and/or a temperature sensor (e.g., for sensing fluid, AVS, skin, or ambient  
10           audible alarm generation. The reusable portion and/or the disposable portion may be configured to generate an alarm to alert the user or a third party to an indicate such things as an operational condition (e.g., power on condition, proper operation of the control assembly, or proper delivery of fluid within a predetermined set of parameters) and a fault condition (e.g., a low power level, a low fluid level, an abnormal temperature level,  
15           a problem with a primary or backup power supply, detection of an occlusion, detection of an air bubble, detection of a fluid leak, decoupling of the reusable portion and the disposable portion, communication failure between the reusable portion and the disposable portion, expiration of the disposable portion, attempted re-use of the disposable portion, detection of abnormal vibration from the pump, or detection of lack  
20           of vibration from the pump). The disposable portion may include a processor for at least one of continuing device operation in the event of a failure, generating an alarm to indicate that a failure has occurred, and providing status information to the control assembly (e.g., operational history of the disposable portion, characteristics of the disposable portion (e.g., manufacturer, model number, serial number), or usage  
25           information (e.g., shelf life, maximum exposure, maximum operation temperature, expiration date, safe dispensing limits for the therapeutic). The control assembly may be configured to selectively prevent operation of the active mechanical assembly and generate an alarm based on status information received from the processor.

          In additional embodiments, the control assembly may include a user input,  
30           operable from outside of the housing, for actuating the mechanical assembly to deliver a predetermined quantity of fluid. The predetermined quantity may be programmable, e.g.,

from a remote controller, and may be delivered as a single bolus or a plurality of pulses. The user input may include a manual control, accessible from outside of the housing, for manual actuation of the mechanical assembly. Additionally or alternatively, the user input may include a network interface for remote actuation of the mechanical assembly  
5 from a remote controller. The control assembly may be configured to generate an alert (e.g., audible alert, a visual alert, a tactile alert, or a query provided from a remote controller) upon attempted actuation of the mechanical assembly via the user input and to require a user confirmation before actuating the mechanical assembly to deliver the predetermined quantity of fluid. The control assembly may be configured to generate an  
10 alert after completing delivery of the predetermined quantity of fluid.

In further additional embodiments, the disposable portion may be configured to support a cannulus in fluid communication with the fluid path and an analyte sensor in communication with the control assembly. Interconnection between the control assembly and the analyte sensor may be established upon engagement of the reusable portion and  
15 the disposable portion. The control assembly may include an analyte sensor interface for direct interconnection with the analyte sensor.

In still further additional embodiments, at least one pad may be situated between an underside of the disposable portion and a patient's skin so as to provide separation between the disposable portion and a patient's skin. The at least one pad may be secured  
20 to the underside of the disposable portion and/or may include adhesive for securing the disposable portion to the patient's skin. Alternatively, the at least one pad may be placed loosely between the underside of the disposable portion and the patient's skin. The at least one pad may be configured to provide for air flow to a portion of the patient's skin covered by the disposable portion when placed on the patient. For example, air flow may  
25 be provided by at least one of passageways through the pad, passageways between pads, and construction of the at least one pad from a porous material.

In still more additional embodiments, the housing may be affixed to a human body using an adhesion system including a first set of three or more members, each member including an adhesive material on at least one side so as to attach to the body  
30 upon application of pressure, the members disposed around a central region; and a second set of three or more members, each member including an adhesive material on at least

one side so as to attach to the body upon application of pressure, the members disposed around the central region, wherein the members of the first set are spaced to allow the members of the second set to attach to the body in spaces provided between the members of the first set, and wherein the members of the second set spaced to allow members of the first set to detach from the body without detaching the members of the second set. At least one member may be perforated so as to allow facile tearing off of the member. At least one peelable backing strip may also be provided. Members of the first set may be a first color and the members of the second set may be a second color different from the first color.

In further embodiments, the housing may be secured using a plurality of tethers coupled to the housing and a plurality of adhesive members for securing the tethers to a patient's skin.

In accordance with another aspect of the invention there is provided a disposable unit for a patch-sized fluid delivery device, the disposable unit removably engageable with a corresponding reusable unit, the disposable unit including a substrate having flexible membrane material thereon and incorporating therein a fluid channel, the fluid channel being part of a fluid path in the disposable unit from a reservoir port to a cannula port and including a series of regions exposed to the flexible membrane material, at least one of such regions being a valve region, so that an active mechanical assembly in the reusable portion can interact mechanically with the regions through the membrane material in such a manner as to achieve pumping of fluid along the fluid path, the active mechanical assembly including a valve actuator operating on the valve region.

In various alternative embodiments, the series of regions may be exposed to a single flexible membrane of the flexible membrane material. A fluid impedance may be included in the fluid path downstream of the regions to as to prevent pumping of fluid along the fluid path at an unsafe flow rate. Such a fluid impedance may include at least one of a tortuous conduit that is an integral part of the fluid channel and tubing that is in fluid communication with the fluid channel. The substrate may include a dispensing chamber formed in the fluid channel of the substrate, such chamber bounded by flexible membrane material forming a dispensing chamber membrane. The dispensing chamber membrane may include a resilient dispensing spring to facilitate contraction of the



dispensing chamber membrane. The series of regions may also include a pump region for operation by a corresponding pump actuator in the reusable unit through the flexible membrane material. The substrate and the flexible membrane material may constitute a fluidic assembly, and the disposable unit may include a disposable base into which the fluidic assembly fits. An adhesive pad may be coupled to a bottom of the disposable base. The reservoir port may include a reservoir interface for coupling with a fluid reservoir, the reservoir port including one of a needle for introduction into the fluid reservoir and a septum for penetration by a fluid reservoir needle so as to provide fluid communication between the fluid reservoir and the fluid path. A latching mechanism may be provided for permitting selective engagement and disengagement with the reusable unit. An electrical power source may be included for providing electrical power to electronics in at least one of the reusable unit and the disposable unit. At least one output selected from the group consisting of an audible output, a visual output, a tactile output, and a wireless output may be included. The disposable unit may be configured for at least one of inserting and supporting a cannulus for fluid communication with the fluid path and an analyte sensor for communication with a control assembly of the reusable unit. The disposable unit may include a mechanism for attaching the disposable unit to a patient. The disposable unit may include a processor for at least one of continuing device operation in the event of a failure, generating an alarm to indicate that a failure has occurred, and providing status information to the reusable portion.

In accordance with another aspect of the invention there is provided a reusable unit for a patch-sized fluid delivery device, the reusable unit removably engageable with a corresponding disposable unit including a substrate having a flexible material thereon and incorporating a fluid channel, the reusable unit including a control assembly having an active mechanical assembly that interacts mechanically with regions of the fluid channel in the substrate, including a valve region, through the flexible membrane material in such a manner as to achieve pumping of fluid along a fluid path including the fluid channel, the active mechanical assembly including a valve actuator for operating on the valve region.

In various alternative embodiments, the disposable unit may include a dispensing chamber bounded by flexible membrane material, and the reusable unit may include a

fluid sensor for communication with the dispensing chamber for measuring fluid flow through the dispensing chamber. A resilient dispensing spring may be provided to facilitate contraction of the dispensing chamber membrane. The fluid sensor may be an acoustic volume sensor. The acoustic volume sensor may include a loudspeaker, and the loudspeaker may be used by the control assembly for both acoustic volume sensing and audible alarm generation. The acoustic volume sensor may include a microphone, and the microphone may be used by the control assembly for both acoustic volume sensing and monitoring pump operation. The reusable unit may include a pump actuator for operating on a pump region of the disposable unit through flexible membrane material.

The active mechanical assembly may include a motor for operation of at least one of the valve actuator and the pump actuator under control of the control assembly, the motor including at least one shape-memory actuator. The reusable unit may include a latching mechanism for permitting selective engagement and disengagement with the disposable unit. The control assembly may include at least one electrical power source for providing electrical power to electronics in at least one of the reusable unit and the disposable unit. The control assembly may include a battery recharging circuit for recharging a battery and a mechanism (e.g., a coil) for providing electrical power to the battery recharging circuit. The control assembly may include a network interface for communication with a remote controller. The control assembly may include at least one alarm output selected from the group consisting of an audible output, a visual output, a tactile output, and a wireless output. The control assembly may include a temperature sensor. The control assembly may include a user input for user actuation of the mechanical assembly to deliver a predetermined quantity of fluid. The control assembly may be configured to selectively prevent operation of the active mechanical assembly and generate an alarm based on a status of the disposable portion.

In accordance with another aspect of the invention there is provided apparatus comprising a patch-sized housing and an active mechanical assembly disposed within the housing, the active mechanical assembly including a mechanical pump and a motor for operation of the mechanical pump, the motor including a plurality of actuators, each capable of operating the pump independently of the other actuators so as to provide for redundancy in the event of failure an actuator.

In various alternative embodiments, the motor may include one or more shape-memory actuators and may include at least one pulley for folding a shape-memory actuator to fit within the reusable portion. The shape-memory actuator may be operated through changes in heat, and the motor may include a heater for operating the shape-memory actuator. Alternatively, the shape-memory actuator may be operated through changes in electrical current passed through at least a portion of the shape-memory actuator. A shape-memory actuator may be electrically coupled so as to provide a plurality of electrical paths of different lengths through the shape-memory actuator for providing different actuation forces or stroke lengths, and a shorter electrical path may be used during normal operation of a pump and a longer electrical path may be used during priming and air-purging of the pump. The motor may include a plurality of shape-memory actuators. The plurality of shape-memory actuators may be of the same length/gauge or may be of different lengths/gauges, and may be used for providing redundant operation of the active mechanical assembly and/or for providing different actuation forces or stroke lengths (e.g., a shorter shape-memory actuator used during normal operation of a pump and a longer shape-memory actuator used during priming and air-purging of the pump).

In accordance with another aspect of the invention there is provided apparatus comprising a patch-sized housing enclosing a fluid delivery assembly and a plurality of electrical power sources for providing electrical power to the fluid delivery assembly. The housing may include a reusable portion and a disposable portion that is removably engageable with the reusable portion, and the plurality of electrical power sources are disposed solely in the reusable portion, solely in the disposable portion, or in both the reusable portion and the disposable portion. The plurality of electrical power sources may include a primary electrical power source and a backup electrical power source. The primary electrical power source may be a rechargeable battery, and the backup electrical power source may be one of a battery and a supercapacitor.

In accordance with another aspect of the invention there is provided apparatus comprising a patch-sized housing enclosing a fluid delivery system, the fluid delivery system including a controller and a plurality of outputs in communication with the

controller, the controller operably coupled generate an alarm through actuation of the plurality of outputs.

In various alternative embodiments, the plurality of outputs may be selected from the group consisting of an audible output, a visual output, a tactile output, and a wireless output. The alarm may be used to indicate at least one of an operational condition (e.g.,  
5 power on condition, proper operation of the control assembly, or proper delivery of fluid within a predetermined set of parameters) and a fault condition (e.g., a low power level, a low fluid level, an abnormal temperature level, a problem with a primary or backup  
10 power supply, detection of an occlusion in the fluid path, detection of an air bubble in the fluid path, detection of a fluid leak, decoupling of the reusable portion and the disposable portion, communication failure between the reusable portion and the disposable portion, expiration of the disposable portion, attempted re-use of the disposable portion, detection of abnormal vibration from the pump, or detection of lack of vibration from the pump).

In accordance with another aspect of the invention there is provided apparatus  
15 comprising a patch-sized housing including a reusable portion and a disposable portion that is removably engageable with the reusable portion, the reusable portion including a control assembly having an active mechanical assembly for use in pumping fluid along a fluid path, the disposable portion including at least one attribute (e.g., operational history of the disposable portion, a characteristic of the disposable portion, or an attribute for  
20 usage of the disposable portion) discernable by the control assembly, wherein the control assembly is operably coupled to selectively prevent operation of the active mechanical assembly and generate an alarm based on the at least one attribute.

In various alternative embodiments, the disposable portion may include a processor for providing attribute information to the control assembly.

In accordance with another aspect of the invention there is provided apparatus  
25 comprising a patch-sized housing including a reusable portion and a disposable portion that is removably engageable with the reusable portion, the reusable portion including a main controller, the disposable portion including a backup controller capable of at least one of continuing an operation normally provided by the main controller and generating  
30 an alarm to indicate a failure of the main controller.

In accordance with another aspect of the invention there is provided apparatus comprising a patch-sized housing enclosing a fluid delivery system, the fluid delivery system including a controller and a user interface in communication with the controller, wherein the controller is operably coupled to control delivery of fluid to a patient and to  
5 test and report responsiveness of the patient via the user interface.

In accordance with another aspect of the invention there is provided a wearable device for parenteral delivery of fluid, the device having at least a reservoir, a pump having a motor, and an exit assembly, and separable reusable and disposable portions, wherein the motor resides in the disposable portion.

10 In various alternative embodiments, all wetted parts may reside in the disposable portion. The motor may include one or more shape-memory actuators to convert a source of potential energy (e.g., heat or electricity) into kinetic energy.

In accordance with another aspect of the invention there is provided a system for pumping fluid to a subject. The system includes a first separable component and a  
15 second separable component. The first separable component includes an inlet fluid path in communication with a fluid source; a pumping chamber for receiving fluid from the inlet fluid path; a dispensing chamber for receiving fluid from the pumping chamber; and an outlet fluid path for carrying fluid from the dispensing chamber to an exit assembly. The second separable component includes a force application assembly for compressing  
20 the pumping chamber and means for sensing flow conditions through the line.

In various alternative embodiments, the force application assembly may cause flow of fluid to the pumping chamber from the inlet fluid path to be restricted while urging fluid from the pumping chamber to the dispensing chamber. The first separable component may include a reservoir as a fluid source.

25 In accordance with another aspect of the invention there is provided a base sled for holding separable components of a device for delivery of a therapeutic fluid. The device includes a bottom adapted for adhesion to the skin of a patient; a fluidic path portion having a pumping chamber and an outlet; and a groove for securely receiving one or more of a fluid cannula and a probe cannula. The sled is adapted to receive a  
30 disposable insulin cartridge and a reusable portion.

In various alternative embodiments, three or more adhesive members may be provided for adhesive attachment to the skin of the patient. The members may be disposed around a central region. An attachment means may be provided for joining the adhesive members to the device. The reusable portion may include a component selected  
5 from the group consisting of: a flow sensor, an assembly for application of force to the pumping chamber, a power source, transceiver electronics, a microprocessor, and an alarm. A mating feature (e.g., a septum or needle) may be provided for the attachment of a fluid reservoir. Leads may be provided for the establishment of signal communication between a probe attached to the probe cannula and the reusable portion.

10 In accordance with another aspect of the invention there is provided an irregularly shaped fluid reservoir adapted for holding a supply of a therapeutic fluid within a patch-sized housing having a correspondingly shaped reservoir holding chamber, the fluid reservoir having a cavity defined by a rigid reservoir body and a flexible reservoir membrane that is sealingly attached to the rigid reservoir body around the periphery of  
15 the cavity, the flexible reservoir membrane including at least one portion that collapses as therapeutic fluid is withdrawn, the irregular shapes of the fluid reservoir and the corresponding reservoir holding chamber providing for proper orientation of the fluid reservoir within the reservoir holding chamber.

In various alternative embodiments, the reservoir may include a port through  
20 which the reservoir can be placed in fluid communication with a corresponding fluid path in the housing. The port may include a septum for penetration by a fluid path needle or a needle for introduction into the fluid path for providing fluid communication between the reservoir and the fluid path. The port may be seated in a neck extending from a reservoir body.

25 These aspects of the invention are not meant to be exclusive and other features, aspects, and advantages of the present invention will be readily apparent to those of ordinary skill in the art when read in conjunction with the appended claims and accompanying drawings.

### **Brief Description of the Drawings**

The foregoing features of the invention will be more readily understood by reference to the following detailed description, taken with reference to the accompanying drawings, in which:

5           FIG. 1 depicts a patient with a patch and a wireless handheld user interface assembly;

            FIG. 2A is a schematic diagram of a fluid-delivery device with feedback control;

            FIG. 2B is a schematic diagram of a fluid-delivery device with feedback control and a reservoir;

10           FIG. 3 is a schematic diagram of a fluid-delivery device having an un-pressurized reservoir;

            FIGS. 4A-4C are schematic sectional diagrams of various embodiments of a flow restrictor;

            FIG. 5 shows a resilient dispensing assembly in series with a flow restrictor;

15           FIG. 6 shows a dispensing assembly having a metering chamber and a sensor;

            FIG. 7 shows a dispensing assembly having a metering chamber with a dispensing spring and a sensor;

            FIG. 8 shows a sectional view of a dispensing assembly with an alternate acoustic path;

20           FIG. 9 shows a schematic view of a dispensing assembly;

            FIG. 10 shows a diaphragm spring for use with a resilient variable-volume dispensing chamber;

            FIG. 11A shows a kinetic profile of an exemplary basal fluid delivery;

            FIG. 11B shows a kinetic profile of an exemplary bolus fluid delivery;

25           FIG. 11C shows kinetic data representing a normal fluid delivery;

            FIGS. 11D-11F show kinetic data representing various fault conditions;

            FIG. 12 shows a flow chart of a sensing and reacting process of an embodiment of the fluid delivery device;

30           FIG. 13 shows a block diagram of a fluidic line with a pressure generation assembly;

            FIG. 14 shows a block diagram of a fluidic line with a valving pump;

FIGS. 15A-15D show schematic diagrams of a pumping mechanism;

FIG. 16 shows a schematic diagram of a pumping mechanism;

FIG. 17 schematically shows a sectional view of an embodiment that includes a shape-memory-wire actuator capable of multiple pumping modes;

5 FIG. 18 schematically shows a sectional view of an embodiment that includes two shape-memory actuators and is capable of multiple pumping modes;

FIG. 19 schematically shows a sectional view of an embodiment that includes shape-memory actuators of differing lengths;

10 FIG. 20A-20B schematically show embodiments for attaching a shape memory actuator;

FIGS. 21A-21B schematically show embodiments for attaching a shape memory actuator to a pumping mechanism;

FIGS. 22 and 23 show pumping mechanisms employing a finger;

FIG. 24 shows a pumping mechanism employing rotating projections;

15 FIG. 25 shows a pumping mechanism employing a plunger and barrel;

FIG. 26 shows a view of a shape-memory actuator in an expanded state;

FIG. 27 shows a view of a shape-memory actuator in a contracted state;

FIG. 28 shows a view of a pumping assembly employing a plunger and barrel, and a shape-memory motor having a lever;

20 FIG. 29 shows a view of a pumping assembly employing a plunger and barrel, and a shape-memory motor;

FIG. 30 shows a view of a pumping device employing a plunger and barrel and a shape-memory motor having a wire in a shaft of the plunger;

FIG. 31 shows a flow line embodiment with a combined pump and reservoir;

25 FIG. 32 schematically shows a sectional view of a valving pump in a resting position;

FIG. 33 schematically shows a sectional view of the valving pump of FIG. 32 in an intermediate position;

30 FIG. 34 schematically shows a sectional view of the valving pump of FIG. 32 in an actuated position;



FIG. 35 schematically shows a sectional view of a pumping diaphragm for use in a valving pump;

FIG. 36 shows a perspective view of a diaphragm spring for use in a pumping diaphragm;

5 FIG. 37 schematically shows a sectional view of a valving pump employing a lever and a shape memory wire actuator;

FIG. 38 schematically shows a sectional view of an embodiment that includes a valving pump which employs a resilient cylindrical flexure;

10 FIG. 39 schematically shows a sectional view of an embodiment that includes a valving pump flexure having a resilient member and a rigid support;

FIG. 40 schematically shows a sectional view of a valving pump, in a resting state, with a diaphragm spring upstream of a flexible membrane;

FIG. 41 schematically shows a sectional view of the valving-pump of FIG. 40, in an intermediate state;

15 FIG. 42 schematically shows a sectional view of the valving-pump of FIG. 40, in an actuated state;

FIG. 43 schematically shows a sectional view of a valving-pump with a diaphragm spring upstream of a flexible membrane, in which a flexible membrane is circumferentially attached to a force application member;

20 FIG. 44 schematically shows a sectional view of a valving-pump with a diaphragm spring upstream of a flexible membrane, which includes a rigid ball for transmitting force;

FIG. 45 schematically shows a sectional view of an embodiment that includes a valving pump having a resilient pump blade;

25 FIG. 46 schematically shows a sectional view of an embodiment that includes an alternative version of a resilient pump blade for use with a valving pump;

FIG. 47 schematically shows a sectional view of an embodiment that includes a valving pump having multiple force application members;

30 FIG. 48 schematically shows, in a resting or filling mode, a pumping mechanism including a bell-crank driven valving-pump and a flow-biasing valve;

FIG. 49 schematically shows the pumping mechanism of FIG. 48 in an actuated state.

FIG. 50 schematically shows a sectional view of a flow-biasing valve in accordance with an embodiment of the invention having a raised valve seat and in a closed position;

FIG. 51 schematically shows a sectional view of the flow-biasing valve of FIG. 50 in an open position;

FIG. 52 schematically shows a sectional view of a flow-biasing valve in accordance with an embodiment of the invention without a raised valve seat and in an open position;

FIG. 53 schematically shows a sectional view of the flow-biasing valve of FIG. 52, in a closed position;

FIG. 54 schematically shows forces that act upon a poppet in the vicinity of a valve outlet in accordance with embodiments of the invention;

FIG. 55 schematically shows, in close-up view, forces that act upon a poppet in the vicinity of a valve inlet in accordance with embodiments of the invention;

FIG. 56 schematically shows a flow-biasing valve with an adjustable cracking pressure in accordance with an embodiment of the invention;

FIGS. 57 and 58 show schematics for flow lines utilizing un-pressurized reservoirs;

FIGS. 59A-59E shows schematics of a fluid flow in a fluid delivery device;

FIGS. 60A-60D shows exploded schematics of the fluid flow in a fluid delivery device;

FIGS. 61A-61C show schematics of a fluid flow in a fluid delivery device;

FIGS. 62A and 62B show schematics of a stand alone device;

FIGS. 63A-63C show cross sectional schematics of embodiments of a device;

FIGS. 64A-64D show cross section schematics of embodiments of a device;

FIGS. 65A-65B show cross section schematics of embodiments of an infusion device connected to a fluid line;

FIGS. 66A-66D show cross section schematics of a sequence of inserting a reservoir into a device;

FIGS. 67A-67F show schematics of embodiments of the fluid delivery device;

FIG. 68 is schematic of one embodiment of the portable pump embodiment of the device connected to a patient;

FIGS. 69A-69B show schematic views of the underside of the housing of a  
5 device;

FIGS. 70-70D are a diagram depicting the various components available in  
embodiments of the fluid delivery device;

FIG. 71 schematically shows components which may be assembled to create a  
fluid delivery device in accordance with an embodiment of the device;

10 FIG. 72 shows a side view of a fluid-delivery device with an acoustic volume-  
measurement component;

FIG. 73 shows a printed circuit board for acoustic volume measurement;

FIG. 74 shows a pictorial view of an embodiment of a device;

15 FIG. 75 shows a pictorial sectional view of an embodiment of fluid delivery  
device;

FIG. 76 shows an exploded pictorial view of an embodiment of a fluid delivery  
device;

FIG. 77 shows an exploded view of components which may be assembled to  
create one embodiment of a fluid delivery device;

20 FIG. 78 shows an exploded view of an embodiment of the fluid delivery device;

FIG. 79 shows a top view of a base of one embodiment of the fluid delivery  
device;

FIG. 80 shows the underside of the top of one embodiment of the fluid delivery  
device;

25 FIGS. 81A-81C show a sequence to illustrate the process of sandwiching the  
reservoir 20 between the top and base;

FIG. 82 shows an exploded top view of a device;

FIG. 83 shows an exploded view of the bottom of one embodiment of the device  
showing the fluid path assembly, the bottom housing and the membrane and adhesive;

30 FIG. 84 shows a bottom view of the base showing a bottom view of a fluid path  
assembly;

FIGS. 85A-85D show exploded, partially exploded and non-exploded views of an embodiment of a device;

FIG. 86A shows a schematic of an infusion and sensor assembly having an infusion device and analyte sensor connected;

5 FIG. 86B shows an exploded view of an infusion and sensor assembly as shown in FIG. 86A with introduction needles;

FIGS. 87A-87E shows a sequence of an embodiment of the infusion and sensor assembly being inserted into a device;

10 FIGS. 88A-88B show one embodiment of an inserter device in a sequence with an infusion and sensor assembly;

FIGS. 88C-88D show a partial cut away view of the inserter in FIG. 88A-88B;

FIG. 89A shows a front view of one embodiment of an inserter device for the insertion of an infusion and sensor assembly;

FIG. 89B shows a rear view of insertion device of FIG. 89A;

15 FIG. 90 shows a perspective view of one embodiment of a cartridge for an infusion and sensor assembly;

FIGS. 91A-91C show perspective front and side views of an inserter device for insertion of infusion and sensor assembly;

20 FIGS. 92A-92F schematically shows a temporal sequence for the operation of one embodiment of an inserter mechanism;

FIG. 92G shows an inserter mechanism having a catch and a cocking lever in a closed position;

FIG. 92H shows an inserter mechanism with a catch and a cocking lever in an open position;

25 FIGS. 93A-93C show a time-series for the insertion of a cannula into a base of a fluid delivery device;

FIGS. 94A-94C shows a temporal sequence for the insertion of a cannula into a base with co-incident connection of the cannula to a fluid line;

FIG. 95 shows a top view of an adhesive patch for holding a fluid delivery device;

30 FIG. 96 schematically shows a sectional view of a fluid-delivery device under an adhesive patch;

FIG. 97 shows a perspective view of two overlapping adhesive patches for holding a fluid delivery device;

FIG. 98 shows a top view of two semicircular adhesive patch portions;

FIG. 99 shows a perspective view of two semicircular adhesive patch portions holding a fluid delivery device;

FIG. 100 shows a perspective view of a semicircular adhesive patch portion being removed by a patient;

FIG. 101 shows a perspective view of a fluid-delivery device being held against a patient using multiple adhesive members and tethers;

FIG. 102A shows a clamp for assembling a device;

FIG. 102B shows a base of a fluid delivery device having keyholes for inserting clamps;

FIG. 102C shows a sectional view of a fluid delivery device assembled with a clamp;

FIG. 103A shows a perspective view of a cam guide for use in assembling a fluid delivery device;

FIG. 103B shows a top view of the cam guide of FIG. 103A;

FIG. 103C shows a perspective view of a clamp pin for use in assembling a fluid delivery device;

FIG. 103D shows an embodiment of a fluid delivery device assembled using a clamp pin and cam guide;

FIG. 104 shows a sectional view of a collapsible reservoir in accordance with one embodiment;

FIG. 105 shows a perspective view the reservoir of FIG. 104;

FIG. 106A-106C shows a series of steps for securing a septum to a cap to produce a reservoir in accordance with one embodiment;

FIG. 107 shows a reservoir filling station in accordance with one embodiment;

FIGS. 108A -108B shows an embodiment of a reservoir filling station in both the open (108A) an closed (108B) positions;

FIG. 109A shows a block diagram of one embodiment of a data acquisition and control scheme for an embodiment of the fluid delivery system;

FIG. 109B shows a block diagram of one embodiment of a data acquisition and control scheme for an embodiment of the fluid delivery system

FIG. 110A shows a flow chart describing the operation of a fluid delivery device according to one embodiment;

5 FIG. 110B shows a flow chart describing the operation of a fluid delivery device according to one embodiment;

FIG. 111 shows a block diagram of a user interface and fluid delivery component in wireless communication with each other;

10 FIG. 112 shows a data flow diagram showing the use of an intermediate transceiver in accordance with one embodiment;

FIG. 113 shows a block diagram for an intermediate transceiver in accordance with one embodiment;

FIG. 114 shows a data flow diagram for a universal patient interface in accordance with one embodiment;

15 FIG. 115 shows a non-disposable portion of the fluid delivery device and a battery recharger in an uncoupled state in accordance with one embodiment;

FIG. 116 shows the non-disposable portion of the fluid delivery device and battery recharger of FIG. 115 in a docked state in accordance with one embodiment; and

20 FIG. 117 is a flowchart depicting a process for measuring the volume of liquid delivered in a pump stroke, in accordance with an embodiment of the invention.

It should be noted that the foregoing figures and the elements depicted therein are not necessarily drawn to a consistent scale or to any scale.

25

### **Detailed Description of Specific Embodiments**

Definitions. As used in this description and the accompanying claims, the following terms shall have the meanings indicated, unless the context otherwise requires:

A “user input” of a device includes any mechanism by which a user of the device or other operator can control a function of the device. User inputs may include mechanical arrangements (e.g., switches, pushbuttons), wireless interfaces for communication with a remote controller (e.g., RF, infrared), acoustic interfaces (e.g., with speech recognition), computer network interfaces (e.g., USB port), and other types of interfaces.

A “button” in the context of a user input such as the so-called “bolus button” discussed below may be any type of user input capable of performing a desired function, and is not limited to a pushbutton.

An “alarm” includes any mechanism by which an alert can be generated to a user or third party. Alarms may include audible alarms (e.g., a speaker, a buzzer, a speech generator), visual alarms (e.g., an LED, an LCD screen), tactile alarms (e.g., a vibrating element), wireless signals (e.g., a wireless transmission to a remote controller or caretaker), or other mechanism. Alarms may be generated using multiple mechanisms simultaneously, concurrently, or in a sequence, including redundant mechanisms (e.g., two different audio alarms) or complementary mechanisms (e.g., an audio alarm, a tactile alarm, and a wireless alarm).

“Fluid” shall mean a substance, a liquid for example, that is capable of flowing through a flow line.

“Impedance” shall mean the opposition of a device or flow line to the flow of fluid therethrough.

“Wetted” describes a component that comes into direct contact with the fluid during normal fluid delivery operations. Since a fluid is not limited to a liquid, a “wetted” component will not necessarily become wet.

A “patient” includes a person or animal who receives fluid from a fluid delivery device, whether as part of a medical treatment or otherwise.

5 “Cannula” shall mean a disposable device capable of infusing fluid to a patient. A cannula as used herein can refer to a traditional cannula or to a needle.

10 “Analyte sensor” shall mean any sensor capable of determining the presence of an analyte in a patient. The embodiments of analyte sensors include, but are not limited to, sensors capable of determining the presence of any viral, parasitic, bacterial or chemical analyte. The term analyte includes glucose. An analyte sensor may communicate with other components within the fluid delivery device (e.g., a controller in a non-disposable portion) and/or with a remote controller.

15 “Dispensing assembly sensor” shall mean a mechanism for determining the volume of fluid present in the dispensing chamber.

20 A “sharp” shall mean anything that is capable of puncturing or poking an animal’s skin, especially a human’s skin. A Sharp may include a cannula, a cannula insertion device, an analyte sensor, or an analyte sensor insertion device. Sharps may be provided individually or may be provided together, for example, in a cartridge.

“Disposable” refers to a part, device, portion or other that is intended to be used for a fixed duration of time, then discarded and replaced.

25 “Non-disposable” refers to a reusable portion that is intended to have an open-ended duration of use.

30 “Patch-sized” shall mean of a size sufficiently small as to be secured, by means such as adhesive or straps, to the skin of a patient and worn as a medical device over a course of administration of substance contained within the device. A medical device small enough to function as an implant is within the scope of this definition.



“Normally present finite fluid impedance” shall mean a finite fluid impedance that is present in the routine course of fluid delivery, i.e., when a fault condition (e.g., an occlusion) is absent.

5

A “passive” impedance is one that is not actively controlled during a pumping cycle.

“Acoustic volume measurement” shall mean quantitative measurement of a relevant volume using acoustical techniques such as described in U.S. Patent Nos. 5,349,852 and 5,641,892, as well as the techniques described herein.

10

A “temperature sensor” includes any mechanism for measuring temperature and communicating temperature information to a controller. The device may include one or more temperature sensors for measuring such things as skin temperature, AVS temperature, ambient temperature, and fluid temperatures.

15

Embodiments of the device, pumping mechanism, system and methods described herein relate to fluid delivery including pumping and volume measurement of fluid as well as the actuation and control of same. Embodiments of the device include a portable or non-portable device for fluid delivery. Some embodiments of the device include a base portion that is disposable and a top portion that is non-disposable. The device includes embodiments where an infusion device is inserted through the base portion and directly into a patient. These device embodiments are patch pump devices. The patch pump may be adhered to the patient using an adhesive, a strap, or other suitable arrangement. The adhesive may have a protective peelable strip which may be removed to expose the adhesive prior to use.

20

25

However, in other embodiments, the fluid delivery device is a portable device where tubing is connected to a fluid line. The tubing is typically connected to a patient through a cannula.

30

In some embodiments where a disposable base and non-disposable top are implemented, the base portion includes parts that are wetted, while the parts included in the non-disposable top portion are typically non-wetted parts.

5 Various embodiments of the pumping mechanism include an upstream inlet valve, a pumping actuation member, a downstream exit valve and a moveable member. In some embodiments, the pumping actuation member and downstream valve functions are implemented using the same device. The pumping mechanism pumps fluid from a reservoir through a fluid line to an exit. The pumping mechanism is typically  
10 employed with a non-pressurized reservoir, however, the scope of the present invention is not limited accordingly.

In one embodiment of the fluid delivery system, the device includes an analyte sensor housing. An analyte sensor is introduced into the patient through the analyte sensor  
15 housing of the base portion of the device. In these embodiments, an infusion device is also introduced through a cannula housing on the base portion of the device. In these embodiments, the device is worn by the user as a patch pump.

The system typically includes a controller, which may include a wireless transceiver.  
20 Thus, the device may be controlled exclusively or in part through a wireless controller device. The controller device may receive information through wireless communication from the analyte sensor and/or the fluid delivery device. The patient or a third party can control the function of the fluid delivery device using the controller device.

25 In one embodiment of the fluid delivery device, the device is an insulin pump and the analyte sensor is a blood glucose sensor. The controller, receiving information relating both to the volume of insulin delivered (or the number of pump strokes over time) and blood glucose data, assists the user in programming the actuation schedule  
30 for the pump mechanism.

An exemplary dispensing assembly and volume sensing device is described herein. The dispensing assembly includes at least one microphone and a loudspeaker. The assembly determines the volume change in a dispensing chamber to determine the volume of fluid pumped. The volume sensing data is used to determine the status of the fluid delivery device. Thus, various controls may rely on the volume sensing data.

In an embodiment of the invention, a user configures the fluid-delivery device via a user interface in order to cause the fluid-delivery device to deliver a fluid in an appropriate manner. In one embodiment, the user interface resides on a separate hand-held user-interface assembly that may communicate wirelessly with the patch. The patch may be disposable, or partially disposable.

An exemplary use of embodiments of the device is for the delivery of insulin to diabetic patients, but other uses include delivery of any fluid, as described above. Fluids include analgesics to those in pain, chemotherapy to cancer patients and enzymes to patients with metabolic disorders. Various therapeutic fluids may include small molecules, natural products, peptide, proteins, nucleic acids, carbohydrates, nanoparticulate suspensions, and associated pharmaceutically acceptable carrier molecules. Therapeutically active molecules may be modified to improve stability in the delivery device (e.g., by pegylation of peptides or proteins). Although illustrative embodiments herein describe drug-delivery applications, embodiments may be used for other applications including liquid dispensing of reagents for high throughput analytical measurements such as lab-on-chip applications and capillary chromatography. For purposes of description below, terms "therapeutic" or "fluid" are used interchangeably, however, in other embodiments, any fluid, as described above, can be used. Thus, the device and description included herein are not limited to use with therapeutics.

Typical embodiments include a reservoir for holding a supply of fluid. In the case of insulin, the reservoir may be conveniently sized to hold an insulin supply sufficient

for delivery over one or more days. For example, a reservoir may hold about 1 to 2 ml of insulin. A 2 ml insulin reservoir may correspond to about 3 days supply for about 90% of potential users. In other embodiments, the reservoir can be any size or shape and can be adapted to hold any amount of insulin or other fluid. In some  
5       embodiments, the size and shape of the reservoir is related to the type of fluid the reservoir is adapted to hold. The fluid reservoir may be eccentrically or irregularly shaped and/or may be keyed in order to deter incorrect installation or usage.

Some embodiments of the fluid delivery device are adapted for use by diabetics, thus,  
10       in these embodiments, the device delivers insulin which supplements or replaces the action of the patient's pancreatic islet beta cells. Embodiments adapted for insulin delivery seek to mimic the action of the pancreas by providing both a basal level of fluid delivery as well as bolus levels of delivery. Basal levels, bolus levels and timing can be set by the patient or another party by using a wireless handheld user  
15       interface. Additionally, basal and/or bolus levels can be triggered or adjusted in response to the output of an integral or external analyte sensor, such as a glucose monitoring device or blood glucose sensor. In some embodiments, a bolus can be triggered by a patient or third party using a designated button or other input means located on the fluid-delivery device. In still other embodiments, the bolus or basal  
20       can be programmed or administered through a user interface located on the fluid delivery device.

FIG. 1 shows a patient 12 wearing a fluid-delivery device 10 and holding a wireless user interface assembly 14 for monitoring and adjusting operation of the fluid-  
25       delivery device 10, in accordance with an exemplary embodiment of the present invention. The user interface assembly 14 typically includes apparatus for entering information (such as touch-screen or keypad) and for transmitting information to the user (such as an LCD display, a speaker or a vibrating alarm). The fluid delivery device is typically small and lightweight enough to remain comfortably adhered to the  
30       patient for several days.

1062-E72WO-615996  
2/9/2007

The fluid delivery device **10** is shown worn on the arm of a patient **12** in FIG. 1. In other embodiments, the fluid-delivery device **10** may be worn at other positions on the patient where the particular fluid being delivered can be utilized advantageously by the patient's body. For example, fluid may be delivered advantageously to the  
5 patient's abdominal area, kidney area, leg or otherwise.

Referring now to FIG. 2A, a schematic representation of a fluid delivery device **10** having a feedback loop **360** from a dispensing assembly **120** to a pumping assembly **16** is shown. The pumping assembly **16** pumps fluid to the dispensing assembly **120**;  
10 the fluid then exits through an exit assembly **17**, which includes a flow restrictor **340** and an output. The output typically includes a cannula and leads to a patient. The dispensing assembly **120** may include a resilient, variable-volume dispensing chamber and at least one microphone and a loudspeaker for measuring parameters related to flow through the output over time. The feedback loop **360** allows  
15 adjustment of the operation of the pumping assembly **16** based on repeated measurements made by the sensor. The flow restrictor **340** creates high impedance between the dispensing assembly **120** and the output of the flow line **5010**. The flow restrictor **340** could be, for example, a section of narrow-bore tubing or microtubing. Referring now to FIG. 2B, in one embodiment, the pumping assembly **16** pumps fluid  
20 from a reservoir **20** to a dispensing assembly **120**.

Referring now to FIG. 3, a block diagram of a further embodiment employing fluidic principles is shown. A flow line **310** couples a reservoir **20**, a pumping assembly **16**, a dispensing assembly **120**, and an exit assembly **17**. The exit assembly **17** may  
25 include a high impedance flow restrictor **340** and an infusion device **5010** – for example, a cannula. The output of the flow restrictor **340** is sent to the infusion device **5010** for delivery to a patient. The flow restrictor **340** has a higher flow impedance than that of the portion of the flow line **310** upstream of the dispensing assembly **120**. Therefore, the pumping assembly **16** is capable of pumping fluid into  
30 the dispensing assembly **120** faster than the fluid can exit the exit assembly **17**. The dispensing assembly **120** may include a variable volume dispensing chamber **122**

having a resilient wall. In embodiments presented below, the resilient wall is a membrane. Examples of membrane materials include silicone, NITRILE, and any other material having desired resilience and properties for functioning as described herein. Additionally, other structures could serve the same purpose. Upon receiving  
5 a charge of fluid as a result of the action of the pumping assembly 16, the resilience of the membrane will allow the chamber 122 to first expand and then to provide the delivery pressure required to drive the fluid contents of the dispensing assembly 120 past the flow restrictor 340 to a patient. When equipped with an appropriate sensor (examples of which are described below), the dispensing assembly 120 may measure  
10 fluid flow through the variable volume dispensing chamber 122 and may provide feedback through the feedback loop 360 to control the timing and/or rate at which the pumping assembly 16 pumps or partially fills the dispensing chamber 122, thereby delivering a desired dose at a desired rate to a patient.

15 Referring again to FIG. 3, additionally, the flow restrictor 340 prevents fluid flow above a specified flow rate. Furthermore, since pressurized fluid delivery is accomplished through the interaction of the pumping assembly 16, the dispensing assembly 120, and the flow restrictor 340, a non pressurized reservoir 20 can be employed.

20  
25 Still referring to FIG. 3, the feedback loop 360 may include a controller 501. The controller 501 may include a processor and control circuitry for actuating a pumping assembly 16 to pump fluid to the dispensing assembly 120. The controller 501 repeatedly receives a parameter related to fluid flow from a sensor, which may be integral to the dispensing assembly 120, and uses this parameter to control the pumping assembly 16 to achieve a desired flow through the output. For example, the controller 501 can adjust the timing or extent of actuation of the pumping assembly  
30 16 to achieve a desired basal or bolus flow rate and/or to deliver a desired basal or bolus cumulative dose. In determining the timing or extent of pumping, the controller

501 may use the output of the sensor (not shown) to estimate (amongst other things) the rate of fluid flow, cumulative fluid flow, or both, and then, based on the estimation, determine an appropriate compensatory action. In the various embodiments, pumping may occur in pulses which can deliver anywhere between 10<sup>-9</sup> liters per pulse to microliters per pulse. A basal or bolus dose may be achieved by delivering multiple pulses. (Examples of basal and bolus dosing are shown and described below).

The use of a partially collapsible non pressurized reservoir 20 may advantageously prevent the buildup of air in the reservoir as the fluid in the reservoir is depleted. The reservoir 20 may be connected to the fluid line 310 through a septum (not shown). Air buildup in a vented reservoir could prevent fluid egress from the reservoir 20, especially if the system is tilted so that an air pocket intervenes between the fluid contained in the reservoir and the septum of the reservoir 20. Tilting of the system is expected during normal operation as a wearable device. FIGS. 104-106C depict various embodiments and views of one embodiment of the reservoir. Additionally, further description of the reservoir is included below.

Referring now to FIGS. 4A-4C, various embodiments of the flow restrictor 340 are shown. Referring now to FIG. 4A, the flow restrictor is a molded flow channel 340, which may be a molded groove in a base (not shown). In one embodiment, the cross section of the molded flow channel 340 is approximately 0.009 inches. In this embodiment, the flow restrictor 340 is molded into an apparatus. Referring now to FIG. 4B, microtubing 340 is shown as an alternate embodiment flow restrictor. In one embodiment, the microtubing has an internal diameter of approximately 0.009 inches. Both the molded flow channel and the microtubing use a long path having a small internal diameter or cross section to impart flow impedance. Referring now to FIG. 4C, a precision orifice is shown as a flow restrictor 340. In one embodiment, the precision orifice is a plate with a laser drilled hole. In alternate embodiments, any flow impedance device or method known in the art can be used.

In contrast to prior-art fluid delivery systems that have an active downstream valve, which may be generally considered to create, in a functional sense, an infinite fluid impedance, the flow restrictor 340 creates a finite fluid impedance. The impedance is also normally present; in contrast to prior-art systems than may occasionally be impeded due to an occlusion. As a result of the finite nature of the fluid impedance, in embodiments that include a dispensing chamber 122, fluid may leak through the exit even while the dispensing chamber 122 is expanding.

FIGS. 5-8 schematically show sectional views of illustrative embodiments of the dispensing assembly 120. It is to be understood that the delivery of fluid for other purposes, such as industrial processes, is within the scope of the present invention, and that the description in particular terms is by way of example only. As shown in FIG. 5, the dispensing assembly 120 may include the variable volume dispensing chamber 122 and a sensor 550. The variable volume dispensing chamber 122 includes a resilient dispensing diaphragm 125, which allows the chamber 122 to expand and contract depending on the flow of fluid into and out of the dispensing assembly 120. In certain embodiments of the invention, the variable-volume dispensing chamber 122 may be detachable from other elements of the dispensing assembly 120, as further discussed herein. The concept of the resilient dispensing diaphragm 125 allowing the chamber 122 to expand and contract is illustrated by the double headed arrow. Metering chamber 122 is considered to comprise a portion of a line 110 characterized by a fluid flow, which is designated, in FIG. 5, by arrow 112. Neither the position nor the nature of the termination of fluid flow 112 or line 110 need limit the scope of the present invention as claimed in certain of the claims appended hereto. The flow restrictor 340 causes fluid to leave the dispensing chamber 122 more slowly than fluid enters the chamber 122 when pumped into the chamber 122 by the pumping assembly 16. As a consequence, the dispensing chamber 122 expands and is pressurized as a fluid charge enters. Dispensing diaphragm 125, deformed by virtue of the expansion of dispensing chamber 122, provides the force needed to deliver the metered volume past the flow restrictor 340 to the exit assembly 17. As discussed above, the sensor 550 repeatedly measures a



parameter, such as a displacement, or a thermodynamic variable or capacitance, that can be related to the volume of the resilient dispensing chamber 122. The volume measurements produced by the sensor 550 may be used to control, through a feedback loop, the timing and rate at which the pumping assembly pumps fluid to the dispensing chamber 122 so that the proper flow of fluid is delivered to exit assembly 17 and to a subsequent line, and thence, for example, to the patient. The sensor 550 may employ, for example, acoustic volume sensing (described in more detail below), or other methods (optical, or capacitive, for other examples) for determining a volume, or a volume-related parameter. Acoustic volume measurement technology is the subject of U.S. Patents Nos. 5,575,310 and 5,755,683 assigned to DEKA Products Limited Partnership, as well as the co-pending provisional U.S. patent application entitled "METHOD OF VOLUME MEASUREMENT FOR FLOW CONTROL", Serial No. 60/789,243, filed April 5, 2006, all of which are hereby incorporated herein by reference. Fluid volume sensing in the nanoliter range is possible with this embodiment, thus contributing to highly accurate and precise monitoring and delivery. Other alternate techniques for measuring fluid flow may also be used; for example, Doppler-based methods; the use of Hall-effect sensors in combination with a vane or flapper valve; the use of a strain beam (for example, related to a flexible member over a fluid chamber to sense deflection of the flexible member); the use of capacitive sensing with plates; or thermal time of flight methods.

Referring now to FIGS. 6 through 9, embodiments are shown in which a sensor utilizes acoustic volume sensing (AVS) technology. A first discussion refers to embodiments depicted in FIGS. 6 and 7. The dispensing assembly 120 has a sensor that includes a reference chamber 127, and a variable volume measurement chamber 121 that is coupled by a port 128 to a fixed-volume chamber 129. While the invention may be practiced with a reference chamber 127, as shown in FIGS. 6 and 7, in certain other embodiments of the invention, no reference volume is provided. It is to be understood that volume 129 is referred to, herein, as "fixed" as a matter of terminology, but that the actual volume may vary slightly, on the time scale of acoustic excitation, as when the region referred to as fixed volume 129 is driven by a

speaker diaphragm. Fluid flows from the pumping assembly 16 to an input 123, through the resilient dispensing chamber 122, and out of an exit channel 124. Due to the high downstream impedance, as fluid enters the dispensing chamber 122, the dispensing diaphragm 125 expands into the variable volume chamber 121. An electronics assembly, which may be arranged on a printed circuit board 126, has a loudspeaker 1202, a sensing microphone 1203, and a reference microphone 1201 for measuring acoustic parameters associated with a gas (typically air) in the variable volume chamber 121, the volume of which is defined by the position of the dispensing diaphragm 125. Sound waves induced by the loudspeaker 1202 travel through the fixed volume chamber 129 to the variable volume chamber 121 via the port 128; sound waves also travel to the reference chamber 127. As the dispensing diaphragm 125 moves with the flow of fluid through the flow line, the volume of air in the variable volume chamber 121 varies, causing related changes in its acoustic characteristics, which may be detected by the loudspeaker and microphone 1203. For the same acoustic stimulations, the reference microphone 1201 may detect acoustic characteristics of the fixed reference volume 127. These reference measurements may, for example, be used to factor out imprecision and to reject common-mode inaccuracies in acoustic stimulation, and other errors. The volume of fluid displaced may be determined by comparing the measured volume of the variable volume chamber 121 to an initial volume of the variable volume chamber 121. Since the total combined volume of the dispensing chamber 122 and variable volume chamber 121 stays constant, the absolute volume of the dispensing chamber 122 can also be estimated.

The embodiment shown in FIG. 6 utilizes an inherently resilient dispensing diaphragm 125, while the embodiment shown in FIG. 7 utilizes a resilient dispensing spring 130, which when combined with a dispensing diaphragm 125, increases the resiliency of the dispensing chamber 122 and may allow the use of a more compliant (i.e., less resilient) dispensing diaphragm 125 than would be required in the embodiment shown in FIG. 5. The dispensing spring 130 is typically positioned

adjacent to the dispensing diaphragm 125 on a side of the diaphragm 125 opposite to the dispensing chamber 122.

5 Alternately, to reduce background noise from the microphone, the loudspeaker 1202 and the sensing microphone 1203 may be coupled to the variable volume chamber 121 via separate ports. As schematically shown in FIG. 8, a loudspeaker 1202 generates pressure waves in a fixed loudspeaker volume 6000 which is acoustically coupled with the variable volume chamber 121 via a loudspeaker port 6020. Pressure waves travel from the loudspeaker 1202, through the loudspeaker port 6020 to the  
10 variable volume chamber 121 and then through a microphone port 6010 before being recorded by the sensing microphone 1203. The loudspeaker port 6020 may include a tube portion 6040 with a flared aperture 6030. The flared aperture 6030 serves to create a uniform length along which sound waves travel for all axial paths of the tube portion 6040. For example, the tube portion 6040 can have the geometry of a  
15 cylinder, such as a right cylinder or right circular cylinder. A similarly flared aperture may also adjoin a tube portion to define the microphone port 6010. In contrast to the AVS sensor of FIGS. 6 and 7, in the embodiment of FIG. 8, pressure waves traveling from the loudspeaker 1202 do not have a direct path to the sensing microphone 1203. Thus, pressure waves from the loudspeaker 1202 are prevented from directly  
20 impacting the sensing microphone 1203 without first passing through the variable volume 121. A lower background signal is therefore received by the microphone and a better signal/noise ratio is achieved. Additionally, an upper shelf 6050 may be included in any of the embodiments of FIGS. 6-8 advantageously reducing the volume of the reference chamber 127.

25

In embodiments to be further described, it may be convenient to separate the sensor and metering chamber portions of the dispensing assembly such that the dispensing chamber is detachable and disposable. In this case, the dispensing chamber resides in a disposable section of the patch, while the sensor resides in the reusable section. The  
30 dispensing chamber may be bounded by a resilient fluid dispensing diaphragm (as shown in FIG. 6 as 122 and 124). Alternately, as in FIG. 7, the dispensing chamber

122 may be bounded by a compliant diaphragm 125. In this case, a dispensing spring 130 can be used to impart resiliency on the dispensing chamber 122. When the sensor 550 and dispensing chamber 122 are brought together, the dispensing spring 130 covers the compliant dispensing diaphragm 125. The dispensing spring 130 and dispensing diaphragm 125 may alternately be employed as a single part defining the dispensing chamber 122.

As shown in FIG. 9, an alternate embodiment of the dispensing assembly is shown. In an embodiment of dispensing assembly 120 depicted in FIG. 9, variable-volume measurement chamber 121 shares a compliant wall (here shown as compliant diaphragm 125) with dispensing chamber 122. Port 128 acoustically couples measurement chamber 121 to fixed volume chamber 129, so as to form an acoustically contiguous region designated generally by numeral 1290. A compressible fluid (typically, air, or another gas) fills the acoustically contiguous region 1290 and is excited by a driving member 1214, itself driven by an actuator 1216. Driving member 1214 may be a diaphragm of a speaker, such as a hearing aid speaker, where actuator 1216 is a voice coil solenoid or piezoelectric element, for example. Within the scope of the invention, driving member 1214 may also be coextensive with actuator 1216, such as where driving member 1214 may, itself, be a piezoelectric element. Driving member 1214 may be contained within a driver module 1212 that may contain, on a side of driving member 1214 distal to fixed volume 129, a reference volume 1220. However, reference volume 1220 is typically not employed in practice of the invention.

A reference microphone 1208 is shown in acoustic communication with fixed volume 129, while a signal microphone 1209 is acoustically coupled to measurement chamber 121. The volume of measurement region 121 may be determined from electronic signals provided by one or more microphones 1208, 1209 on the basis of pressure variations (or, equivalently, acoustic signal) measured at their respective positions within the acoustically contiguous region 1290. Phase measurements may be performed by comparing the phase of response at one or more microphones relative

to the phase of acoustic excitation or relative to the phase of response at a position of another microphone. The volume of measurement region 121, and, by implication, of dispensing chamber 122, is determined, on the basis of phase and/or amplitude measurements, as discussed below, by a processor 1210, which derives power from power source 1211, shown, representatively, as a battery.

For the purposes of precise delivery of minute amounts of therapeutic agents, the delivery of small, but very accurately metered, quantities per pump stroke is desirable. However, if minute volumes of fluid are to be pumped through line 110 during the course of each pump stroke, extremely high resolution is required of the metering process. Consequently, in accordance with embodiments of the present invention, changes in volume are measured by sensor 550 with a resolution of at least 10 nanoliters. Measurements of resolution 0.01% of the empty volume of measurement region 121 may be achieved in some embodiments of the invention. In accordance with other embodiments of the invention, sensor 550 provides resolution of better than 13 nanoliters. In other embodiments yet, sensor 550 provides resolution of better than 15 nanoliters, and in yet further embodiments, resolution of better than 20 nanoliters is provided. In such cases, the total volume of acoustically contiguous region 1290 may be less than 130  $\mu\text{l}$ , and, in other embodiments, less than 10  $\mu\text{l}$ .

In accordance with various embodiments of the present invention, use may be made of *a priori* modeling of the response of the volume of dispensing chamber 122, and, consequently of variable-volume chamber 121 (which may also be referred to, herein, as a "metering volume"), based upon the filling of the dispensing chamber due to a pumped volume of fluid entering through input 123. While other models are within the scope of the present invention, one model that may be employed expresses the volume of fluid within dispensing chamber 122, in response to a pumped influx of fluid and a outlet of fixed flow impedance, as the sum of a baseline volume  $V_B$  and an exponentially decaying volume characterized by a peak displacement  $V_D$ , such that the metering chamber volume during a measurement is characterized as a function of time  $t$ , as:

$$V = V_D \exp\left(\frac{-t}{\tau}\right) + V_B .$$

In order to fit a parameterization of the modeled exponential decay (or other functional model) to a succession of acoustic measurements, the response of systems such as depicted in FIGS. 6 through 9 is developed as follows. For purposes of modeling the response, port 128 is characterized by a length  $l$  and a diameter  $d$ . The pressure and volume of an ideal adiabatic gas can be related by  $PV^\gamma = K$ , where  $K$  is a constant defined by the initial conditions of the system.

The ideal adiabatic gas law can be written in terms of a mean pressure,  $P$ , and volume,  $V$ , and a small time-dependent perturbation on top of those pressures,  $p(t)$ ,  $v(t)$  :

$$(P + p(t))(V + v(t))^\gamma = K .$$

Differentiating this equation yields

$$\dot{p}(t)(V + v(t))^\gamma + \gamma(V + v(t))^{\gamma-1}(P + p(t))\dot{v}(t) = 0$$

Or, simplifying,

$$\dot{p}(t) + \gamma \frac{P + p(t)}{V + v(t)} \dot{v}(t) = 0$$

If the acoustic pressure levels are much less than the ambient pressure the equation can be further simplified to:

$$\dot{p}(t) + \frac{\gamma P}{V} \dot{v}(t) = 0$$

Applying the ideal gas law,  $P = \rho RT$ , and substituting in for pressure gives the result:

$$\dot{p}(t) + \frac{\gamma RT \rho}{V} \dot{v}(t) = 0$$

This can be written in terms of the speed of sound,  $a = \sqrt{\gamma RT}$ , as:

$$\dot{p}(t) + \frac{\rho a^2}{V} \dot{v}(t) = 0$$

Also, an *acoustic impedance* for a volume is defined as:

$$Z_v = \frac{p(t)}{\dot{v}(t)} = -\frac{1}{\left(\frac{V}{\rho a^2}\right)s} = -\frac{\rho a^2}{V} \cdot \frac{1}{s}$$

5

In accordance with one set of models, the acoustic port is modeled assuming that all of the fluid in the port essentially moves as a rigid cylinder reciprocating in the axial direction. All of the fluid in the channel (port 128) is assumed to travel at the same velocity, the channel is assumed to be of constant cross section, and the “end effects” resulting from the fluid entering and leaving the channel are neglected.

10

Assuming laminar flow friction of the form  $\Delta p = R\rho\dot{v}$ , the friction force acting on the mass of fluid in the channel can be written:  $F = R\rho A^2\dot{x}$

15

A second order differential equation can then be written for the dynamics of the fluid in the channel:

$$\rho LA\ddot{x} = \Delta pA - R\rho A^2\dot{x}$$

or, in terms of volume flow rate:

$$\ddot{v} = -\frac{RA}{L}\dot{v} + \Delta p \frac{A}{\rho L}$$

20

The acoustic impedance of the channel can then be written:

$$Z_p = \frac{\Delta p}{\dot{v}} = \frac{\rho L}{A} \left( s + \frac{RA}{L} \right)$$

Using the volume and port dynamics define above, the acoustic volume sensor system can be described by the following system of equations (with index k denoting the speaker, and r denoting the resonator):

$$\dot{p}_0 - \frac{\rho a^2}{V_0} \dot{v}_k = 0$$

5 Following the same convention,  $\dot{v}_k > 0 \Rightarrow \dot{p}_1 < 0$  and  $\dot{v}_r > 0 \Rightarrow \dot{p}_1 > 0$ ,

$$\dot{p}_1 + \frac{\rho a^2}{V_1} (\dot{v}_k - \dot{v}_r) = 0$$

In addition,  $\dot{v}_r > 0 \Rightarrow \dot{p}_2 < 0$ ,

$$\dot{p}_2 + \frac{\rho a^2}{V_2} \dot{v}_r = 0$$

10

The volume tends to accelerate in a positive direction if  $p_2$  is larger than  $p_1$ .

$$\ddot{v}_r = -\frac{RA}{L} \dot{v}_r + \frac{A}{\rho L} (p_2 - p_1).$$

Reducing the number of equations (treating  $p_0$  as input), and substituting

$$\dot{v}_k = \frac{V_0}{\rho a^2} \dot{p}_0,$$

15

$$\dot{p}_1 + \frac{V_0}{V_1} \dot{p}_0 - \frac{\rho a^2}{V_1} \dot{v}_r = 0$$

$$\dot{p}_2 + \frac{\rho a^2}{V_2} \dot{v}_r = 0$$

$$\ddot{v}_r = -\frac{RA}{L} \dot{v}_r + \frac{A}{\rho L} p_1 - \frac{A}{\rho L} p_2$$

20

This leads to one simple expression using these equations:



$$\frac{\rho a^2}{V_2} \dot{v}_r = \frac{V_1}{V_2} \cdot \left( \frac{\rho a^2}{V_1} \dot{v}_r \right) = \frac{V_1}{V_2} \dot{p}_1 + \frac{V_0}{V_2} \dot{p}_0$$

$$\dot{p}_2 + \frac{V_0}{V_2} \dot{p}_0 + \frac{V_1}{V_2} \dot{p}_1 = 0$$

$$V_0 \dot{p}_0 + V_1 \dot{p}_1 = -V_2 \dot{p}_2$$

$$-\frac{V_0 \dot{p}_0 + V_1 \dot{p}_1}{\dot{p}_2} = V_2, \quad \text{or}$$

$$V_0 p_0 + V_1 p_1 = -V_2 p_2$$

$$-\frac{V_0 p_0 + V_1 p_1}{p_2} = V_2$$

These equations can also be expressed in transfer function form. The “cross-speaker” transfer function,  $p_1/p_0$ , is:

5

$$s \cdot p_1 + \frac{V_0}{V_1} s \cdot p_0 - \frac{\rho a^2}{V_1} s \cdot v_r = 0$$

$$s \cdot p_2 + \frac{\rho a^2}{V_2} s \cdot v_r = 0$$

$$s^2 \cdot v_r = -\frac{RA}{L} s \cdot v_r - \frac{A}{\rho L} p_1 + \frac{A}{\rho L} p_2$$

$$p_2 = -\frac{\rho a^2}{V_2} v_r$$

$$s^2 v_r = -\frac{RA}{L} s \cdot v_r + \frac{A}{\rho L} \left( -\frac{\rho a^2}{V_2} \right) v_r - \frac{A}{\rho L} p_1$$

$$\left( s^2 + \frac{RA}{L} s + \frac{A a^2}{L V_2} \right) v_r = -\frac{A}{\rho L} p_1$$

$$v_r = \frac{-\frac{A}{\rho L}}{s^2 + \frac{RA}{L} s + \frac{A a^2}{L V_2}} p_1$$

or

$$\frac{p_1}{p_0} = -\frac{V_0}{V_1} \frac{s^2 + 2\zeta\omega_n s + \alpha\omega_n^2}{s^2 + 2\zeta\omega_n s + \omega_n^2}$$

where

$$\omega_n^2 = \frac{\alpha^2 A}{L} \left( \frac{1}{V_1} + \frac{1}{V_2} \right); \quad \zeta = \frac{RA}{2L\omega_n}; \quad \text{and} \quad \alpha = \frac{V_1}{V_1 + V_2} .$$

5

Similarly, the “cross system” transfer function, based on measurements on either end of port 128, is  $p_2/p_0$ , is given by:

$$s \cdot p_1 + \frac{V_0}{V_1} s \cdot p_0 - \frac{\rho a^2}{V_1} s \cdot v_r = 0$$

$$s \cdot p_2 + \frac{\rho a^2}{V_2} s \cdot v_r = 0$$

10

$$s^2 \cdot v_r = -\frac{RA}{L} s \cdot v_r - \frac{A}{\rho L} p_1 + \frac{A}{\rho L} p_2$$

$$p_1 = \frac{\rho a^2}{V_1} v_r - \frac{V_0}{V_1} p_0$$

$$s^2 v_r = -\frac{RA}{L} s \cdot v_r - \frac{A}{\rho L} \cdot \frac{\rho a^2}{V_1} v_r - \frac{A}{\rho L} \left( -\frac{V_0}{V_1} p_0 \right) + \frac{A}{\rho L} p_2$$

$$v_r = \frac{\frac{AV_0}{\rho LV_1}}{s^2 + \frac{RA}{L} s + \frac{Aa^2}{LV_1}} p_0 + \frac{\frac{A}{\rho L}}{s^2 + \frac{RA}{L} s + \frac{Aa^2}{LV_1}} p_2$$

$$s \cdot p_2 + \frac{\rho a^2}{V_2} s \cdot \left[ \frac{\frac{AV_0}{\rho LV_1}}{s^2 + \frac{RA}{L} s + \frac{Aa^2}{LV_1}} p_0 + \frac{\frac{A}{\rho L}}{s^2 + \frac{RA}{L} s + \frac{Aa^2}{LV_1}} p_2 \right] = 0$$

15

$$\left[ s^2 + \frac{RA}{L} s + \frac{Aa^2}{LV_1} + \frac{Aa^2}{LV_2} \right] p_2 = -\frac{Aa^2}{LV_2} \cdot \frac{V_0}{V_1} p_0$$

$$\frac{p_2}{p_0} = -\frac{V_0}{V_1} \frac{\frac{Aa^2}{LV_2}}{s^2 + \frac{RA}{L} s + \frac{Aa^2}{LV_2} \cdot \frac{V_1 + V_2}{V_1}}$$

$$\frac{p_2}{p_0} = -\frac{V_0}{V_1} \frac{\alpha\omega_n^2}{s^2 + 2\zeta\omega_n s + \omega_n^2}$$

*Volume Estimation Using Cross-System Phase*

Similarly, using the same principles, a transfer function is readily derived, expressing a pressure in the fixed volume chamber 129 in terms of the pressure in the variable volume chamber 121 to which it is coupled via port 128. In particular, the transfer function is:

5

$$\frac{p_2}{p_1} = \frac{1}{\frac{V_2 L_p}{a^2 A_p} s^2 + \frac{R V_2}{a^2} s + 1} = \frac{\frac{a^2 A_p}{V_2 L_p}}{s^2 + \frac{R V_2}{a^2} \frac{a^2 A_p}{V_2 L_p} s + \frac{a^2 A_p}{V_2 L_p}}$$

$$= \frac{\omega_n^2}{s^2 + \frac{R A_p}{L_p} s + \omega_n^2}$$

10 In either of the foregoing cases, the resonant frequency of the system may be expressed as a function of the variable volume,  $V_2$ :

$$\omega_n^2 = \frac{a^2 A}{L} \left( \frac{1}{V_1} + \frac{1}{V_2} \right), \text{ or } \frac{1}{V_2} = \frac{\omega_n^2 L}{a^2 A} - \frac{1}{V_1}$$

15 Since all of the other parameters are known, variable volume  $V_2$  can be calculated based, for example, on the resonant frequency, although other methods of deriving  $V_2$  may be advantageous, and are described further in the course of the present application. The one parameter that is not a constant in this equation is the speed of sound,  $a$ , which may be calculated, based on a knowledge of the pertinent  
 20 temperature, or otherwise derived or measured.

As stated, various strategies may be employed to interrogate the system so as to derive volume  $V_2$ . In accordance with certain embodiments of the current invention, the system is excited by driving member 1214 at a single frequency, while monitoring

the response of one or more transducers (microphones **1208** and **1209**, in FIG. 9). The response is captured as a complex signal, retaining both amplitude and phase of the pressure variation. It is advantageous that the single interrogating frequency lie close to the resonance of the system in mid-stroke, since the largest phase changes with volume over the range of a full to empty chamber is thereby achieved.

The response of the signal microphone **1208** may be corrected to reject common-mode effects due to the frequency-dependent characteristics of the exciting loudspeaker **1202** (shown in FIG. 6) or driving member **1214** (shown in FIG. 9). The corrected signal, obtained as a complex ratio of the microphone signals, may be expressed as  $m_i$ , where the index  $i$  denotes successive time samples of the signal.

Expressed, in transfer function form, in analogy, to a second-order mechanical Helmholtz resonator, the signal may be represented as:

$$\begin{aligned}
 m_i &\approx \frac{V_0}{V_1} \frac{\frac{A\gamma RT}{LV_2}}{s_i^2 + \frac{\lambda A}{L} s_i + \frac{A\gamma RT}{LV_2} \cdot \frac{V_1 + V_2}{V_1}} = \frac{\frac{V_0}{V_1} \cdot \frac{A\gamma R}{L\omega_c^2} \cdot \frac{T_i}{V_2} \cdot \frac{\alpha}{\varepsilon_{v,i}}}{\frac{s_i^2}{\omega_c^2} + \frac{A\lambda}{L\omega_c} \cdot \varepsilon_\lambda \cdot \frac{s_i}{\omega_c} + \frac{A\gamma R}{L\omega_c^2} \cdot \frac{T_i}{V_1} \cdot \frac{(\varepsilon_{v,i} + \Psi_{1,2})}{\varepsilon_{v,i}}} \\
 &= \frac{-\kappa_{0,i} \frac{\alpha}{\varepsilon_{v,i}}}{\bar{s}_i^2 + \psi_1 \cdot \bar{s}_i \cdot \varepsilon_\lambda + \psi_{0,i} \frac{\Psi_{1,2} + \varepsilon_{v,i}}{\varepsilon_{v,i}}} = \frac{-\kappa_{0,i} \alpha}{\bar{s}_i^2 \varepsilon_{v,i} + \psi_1 \bar{s}_i \varepsilon_\lambda \varepsilon_{v,i} + \psi_{0,i} (\Psi_{1,2} + \varepsilon_{v,i})} \\
 &= \frac{i^{-\kappa_{0,i}} \alpha}{\left[ \psi_{0,i} (\Psi_{1,2} + \varepsilon_{v,i}) - \bar{\omega}_i^2 \varepsilon_{v,i} \right] + l \cdot \psi_1 \bar{\omega}_i \varepsilon_\lambda \varepsilon_{v,i}} \cdot \frac{\left[ \psi_{0,i} (\Psi_{1,2} + \varepsilon_{v,i}) - \bar{\omega}_i^2 \varepsilon_{v,i} \right] - l \cdot \psi_1 \bar{\omega}_i \varepsilon_\lambda \varepsilon_{v,i}}{\left[ \psi_{0,i} (\Psi_{1,2} + \varepsilon_{v,i}) - \bar{\omega}_i^2 \varepsilon_{v,i} \right] - l \cdot \psi_1 \bar{\omega}_i \varepsilon_\lambda \varepsilon_{v,i}} \\
 &= \frac{-\kappa_{0,i} \alpha \left[ \psi_{0,i} \Psi_{1,2} + (\psi_{0,i} - \bar{\omega}_i^2) \varepsilon_{v,i} \right] + l \cdot \kappa_{0,i} \alpha \psi_1 \bar{\omega}_i \varepsilon_\lambda \varepsilon_{v,i}}{\left[ \psi_{0,i} \Psi_{1,2} + (\psi_{0,i} - \bar{\omega}_i^2) \varepsilon_{v,i} \right]^2 + \psi_1^2 \bar{\omega}_i^2 \varepsilon_\lambda^2 \varepsilon_{v,i}^2}
 \end{aligned}$$

Here, normalization variables have been introduced so as to maintain relevant parameters within a computationally useful dynamic range of order unity. The final expression is expressed in terms of the real and imaginary parts over a common

denominator. Taking the ratio of the real  $\mu$  to the imaginary  $v$  parts, (*i.e.*, the phase cotangent),

$$\frac{\mu_i}{v_i} \approx - \frac{(\psi_{0,i} - \bar{\omega}_i^2) \varepsilon_{v,i} + \psi_{0,i} \Psi_{1,2}}{\psi_1 \bar{\omega}_i \varepsilon_\lambda \varepsilon_{v,i}} ,$$

the error may be defined as:

5 
$$E = \frac{1}{M} \sum [\mu_i D_i + v_i N_i]^2 ,$$

with N and D denoting the numerator and denominator, respectively of the model.

If the error is minimized with respect to each of the model parameters, a best-fit has been achieved. Any method may be employed for fitting the model parameters. In one embodiment of the invention, a gradient-descent method is employed to find the minima:

$$\frac{\partial E}{\partial \varepsilon_\lambda} = \frac{2}{M} \sum \psi_1 \bar{\omega}_i \varepsilon_{v,i} D_i e_i$$

$$\frac{\partial E}{\partial \varepsilon_b} = \frac{2}{M} \sum \left( \mu_i \frac{\partial D_i}{\partial \varepsilon_b} + v_i \frac{\partial N_i}{\partial \varepsilon_b} \right) e_i = 2 \sum \left( \mu_i \frac{\partial D_i}{\partial \varepsilon_{v,i}} + v_i \frac{\partial N_i}{\partial \varepsilon_{v,i}} \right) e_i \frac{\partial \varepsilon_{v,i}}{\partial \varepsilon_b}$$

$$\frac{\partial D_i}{\partial \varepsilon_{v,i}} = \psi_1 \bar{\omega}_i \varepsilon_\lambda$$

$$\frac{\partial N_i}{\partial \varepsilon_{v,i}} = \psi_{0,i} - \bar{\omega}_i^2$$

$$\frac{\partial \varepsilon_{v,i}}{\partial \varepsilon_b} = 1$$

15

$$\frac{\partial E}{\partial \delta_d} = \frac{2}{M} \sum \left( \mu_i \frac{\partial D_i}{\partial \varepsilon_{v,i}} + v_i \frac{\partial N_i}{\partial \varepsilon_{v,i}} \right) e_i \frac{\partial \varepsilon_{v,i}}{\partial \delta_d}$$

$$\frac{\partial \varepsilon_{v,i}}{\partial \delta_d} = \exp\left(-t_i \varepsilon_\tau / \tau\right)$$

$$\frac{\partial E}{\partial \varepsilon_\tau} = \frac{2}{M} \sum \left( \mu_i \frac{\partial D_i}{\partial \varepsilon_{v,i}} + v_i \frac{\partial N_i}{\partial \varepsilon_{v,i}} \right) e_i \frac{\partial \varepsilon_{v,i}}{\partial \varepsilon_\tau}$$

$$\frac{\partial \varepsilon_{v,i}}{\partial \varepsilon_\tau} = \delta_d \frac{-t_i}{\tau} \exp\left(-t_i \varepsilon_\tau / \tau\right)$$

The intervals over which each successive temporal sample is obtained, and the  
 5 number of intervals sampled in order to fit the parameters of the temporal model are  
 advantageously optimized for each specific application of the invention. Where fluid  
 flows at a slow but relatively constant rate, as in basal insulin delivery, sampling over  
 a period from  $\tau/3$  to  $3\tau$  has been found efficacious. On the other extreme, where a  
 relatively large bolus of fluid is to be delivered, the fluid may reside in dispensing  
 10 volume **122** for only a short period of time, on the time scale of the exponential decay  
 time constant. In that case, sampling is performed over a shorter fraction of the  
 characteristic decay time.

In accordance with preferred embodiments of the invention, volume of fluid  
 15 dispensed through dispensing volume **122** is determined on the basis of a fit to a  
 model of volume vs. time, based on cross-system phase measurements made at  
 monotonic frequency of excitation. During the initial portion of a pump stroke,  
 moreover, preliminary measurements are made in order to calibrate system operation,  
 as now described, in conjunction with the measurement protocol, with reference to  
 20 the flowchart shown in FIG. 117. The metering process, denoted generally by  
 numeral **1170**, advantageously conserves computer resources and minimizes power  
 consumption, thereby extending the useful time between charges or replacement of  
 power source **1211** (shown in FIG. 9), while providing, through frequent calibration,  
 the measurement accuracy required for delivery of fluid with the resolution per stroke  
 25 described above.

Either prior to, or at the beginning **1171** of, each pump stroke, or both, processor  
**1210** initiates a Self-Calibration Phase **1172** of the AVS system. Measurements are  
 held-off until electronic transients due to activation of the pump have substantially

decayed. Microphone and speaker gains are set, and driving member 1214 is actuated, in step 1173, at a succession of frequencies, where typically five frequencies are employed, in the general proximity of the resonance of contiguous acoustic region 1290 (otherwise referred to herein as the “acoustic chamber”). Frequencies in the range of 6-8 kHz are typically employed, though the use of any frequencies is within the scope of the present invention. At the onset of activation of each successive frequency, data collection is delayed, for a period of approximately 5 ms, until acoustic transients have substantially decayed.

For a duration of approximately 64 acoustic cycles, data are collected as follows: the temperature reading provided by temperature sensor 132 (shown in FIG. 70B) is sampled in step 1174, and the real and imaginary portions of the ratio of output signals of signal microphone 1209 with respect to reference microphone 1208, denoted  $\rho$  and  $\iota$ , respectively, are sampled. The complex ratio of signals, or other functional combination of the microphone signals with respect to the reference, may be referred to herein as the “signal,” for purposes of describing the AVS system.

On the basis of measurements at each frequency, taken over the course of approximately 200 ms per frequency, a set of means and variances are derived for each of the real and imaginary parts of the signal at each frequency and for the temperature readings. Analysis, in step 1175, of these values, permits a determination of whether errors are within specified bounds. An anomalous transfer function may advantageously indicate system faults that include, but are not limited to, faults in the microphones or other sensors, speaker, transducer, electronics, mechanical components, fluid ingress, poor acoustic seal, excessive ambient noise, and excessive shock and vibration. Additionally, the functional dependence of the phase angle of the signal as a function of frequency is determined in step 1176. The phase angle of the signal, namely the arctangent of the ratio of imaginary to real portions thereof, may be used as a measure of phase, however any measure of phase may be used within the scope of the invention. The functional dependence may be derived by polynomial fit of the phase to the frequency, or otherwise. On the basis of the polynomial fit, or

otherwise, the slope of phase vs. frequency is determined at the volume measurement frequency, and volume measurement proceeds, in step 1177. Additionally, and significantly, an anomalous slope of phase vs. frequency is indicative of a gaseous bubble in the fluid contained within dispensing chamber 122.

5

For a succeeding portion of each pump stroke, driving member 1214 is actuated at substantially a single frequency, thereby acoustically exciting the gas within acoustically contiguous region 1290 at that frequency. Signal data, based typically on the complex ratio of output signals of signal microphone 1209 with respect to reference microphone 1208 are collected and averaged over specified sampling intervals of approximately 64 cycles. Real and imaginary components of the signal, as well as temperature data, are recorded for each sampling interval. Based on the sampled and collected data, a fit is performed to a temporal model. In various embodiments of the invention, a gradient-descent method is employed, as described above, in order to minimize error in fitting the model parameters, namely the baseline volume  $V_B$ , peak displacement  $V_D$ , and decay time  $\tau$ , of the variable volume chamber 121 during the course of each pump stroke, thereby providing the volume of fluid delivered through dispensing chamber 122.

10  
15

Referring now to FIG. 10, the dispensing spring 130 may have a spiral or fan shape that is complementary to the diaphragm and may have multiple helical grooves 131. Embodiments of the spring as shown can apply an approximately even force over the diaphragm. This approximately even force helps the diaphragm to retain an approximately concave shape as it expands. The grooves 131 allow air to pass freely through the spring, thus most air is not trapped between the spring and the diaphragm.

20  
25

Referring now to FIGS. 11A and 11B, examples of kinetic measurements of the volume of the dispensing chamber 122 (shown in FIG. 5) and of the calculated cumulative volume expelled from the dispensing chamber 122 are shown for a typical basal delivery pulse (FIG. 11A) and for a typical bolus delivery (FIG. 11B). As can be seen in FIG. 11A, actuation of the pumping assembly 16 causes an expansion of

30



the dispensing chamber **122**, as measured by the acoustic volume sensor **550**, from about 0 to about 1.5  $\mu\text{l}$  in about 2 seconds. The resilient dispensing chamber **122** is seen to contract and expel its fluid from the chamber **122** through the high impedance output over a course of about 30 seconds with an exponential decay kinetic  
5 characterized by a half-life ( $t_{1/2}$ ) of about 6 seconds. The cumulative volume of output from dispensing chamber **122** is calculated from the measurements made by the sensor **550** and seen also to rise exponentially to about 1.5  $\mu\text{l}$ . It can be seen that the high impedance output introduces a delay between actuation of the pump assembly and delivery of the majority of the displaced fluid. The  $t_{1/2}$  characteristic of the  
10 system can be chosen with attention to the resilient force exerted by the dispensing chamber **122** and the degree of impedance of the output. In various embodiments, the time constant may vary to save power and eliminate drift issues. The time constant may be, for example,  $t_{1/2} = 2$  seconds, or  $t_{1/e} = 2$  seconds.

15 FIG. 11B shows a kinetic profile of a bolus delivery of fluid by the fluid delivery device **10**. A rapid succession of about 29 pump actuations (i.e., pulses) each displace fluid from a fluid source into the resilient dispensing chamber **122**, thus causing corresponding changes in the parameter measured by the acoustic volume measurement sensor **550**. It can be seen that the volume of the dispensing chamber  
20 **122** expands on the first pump pulse to about 1.5  $\mu\text{l}$ , a value similar to that observed in FIG. 11A. The dispensing chamber **122** volume further expands upon additional pulsatile pumping at pulse intervals shorter than the time period required to achieve full discharge of the dispensing assembly **120**; the expansion reaches a maximum of about 6  $\mu\text{l}$ . Cessation of the pump pulsing occurs after about 85 seconds and the  
25 volume of the chamber **122** is seen to decrease with an exponential decay kinetic resulting in complete discharge of its contents by about 30 seconds after cessation of pumping. The  $t_{1/2}$  for this final discharge is approximately the same as for the basal delivery shown in FIG. 11A. The calculated cumulative output volume is seen to rise during pumping with an approximately linear kinetic and plateau upon cessation of  
30 pumping.

In the described system, fault conditions are detected by volume measurements rather than by pressure measurements, thus, faults may be determined in seconds. FIGS. 11C-11F illustrate the sensor 550 of FIGS. 5-7 detection various types of fault conditions. All description with respect to FIGS. 11C-11F are described with reference to FIGS. 5-7.

FIG. 11C shows a kinetic profile of sensor 550 output over time for a pumping pulse under normal operating conditions. In contrast, Fig 11D shows an expected result of an occlusion downstream of the dispensing assembly 120; the increasing (or not decreasing) volume of fluid in the dispensing chamber 122 is quickly detected by the sensor 550.

Low volume conditions are shown in FIGS. 11E-11F. In FIG. 11E, an approximate maximum sensor signal is reached, followed by an overly fast decay; this condition may indicate an internal leak in the pump 16, line 310, or dispensing assembly 120. The kinetic profile of FIG. 11F has a low peak volume signal and may be representative of a pump failure, an empty reservoir 20, or an occlusion that is upstream of the dispensing chamber 122. Delayed expansion of the dispensing chamber 122 in response to pump actuation may also indicate a problem in the flow line 310. The sensor 550 may also be capable of detecting bubbles in the fluid. An alarm can be activated in response to detection of a fault condition.

FIG. 12 shows a flow chart depicting a cycle of acoustic volume sensing and compensation (corresponding to control loop 360 of FIGS. 2A-3). The sensor may measure the amount of fluid dispensed from the device 10 based on measures of the magnitude of the cyclical changes in the variable volume chamber 121 induced by the pumping cycles. For example, the sensor 550 may repeatedly acquire acoustic spectra of the resonant variable volume 121 and the reference volume chamber 127 (step 2611) and maintains a parameter, which, for each pumping pulse, is updated to incorporate the decrease in volume of gas in the variable volume chamber 121.

Accordingly the updated parameter indicates the net quantity of fluid that has entered the dispensing chamber 122. The fluid entering the dispensing chamber 122 is approximately equal to the volume that has been dispensed by the device 10 if there is sufficient delay between pulses. Alternately, the sensor 550 can repeatedly measure the increase in the volume of gas in the variable volume chamber 121 to determine the amount dispensed by the device (if there is a sufficient delay between pulses). Acoustic spectra are compared to model spectra in a lookup table that may correspond to any or all of a dispensing chamber 122 with a bubble, without a bubble, or with bubbles of varying sizes (step 2621). The lookup table may hold data acquired experimentally, determined using a model, or determined to work empirically. The lookup table may contain data representing varying bubble containing and/or normal conditions for multiple degrees of expansion of dispensing chamber 122. If the spectrum and updated sum fit a model of normal flow (step 2631), another acoustic spectrum is acquired and the cycle is repeated at step 2611. If the spectrum and/or the updated sum do not fit a model of normal flow, the presence of a low or occluded flow will be determined (step 2641). A low or occluded flow may be indicated by a persistently out-of-range volume of the variable volume chamber 121, by an updated sum that is lower than a predicted or set value, or both. If a low or occluded flow condition is detected, an alarm will be triggered (step 2671). Alarms may include audible signals, vibrations, or both. If no condition of low or occluded flow is found, the device determines if the spectrum fits a model corresponding to a condition of a bubble in the dispensing chamber 122 (step 2661). If a bubble is determined to be present, a reaction is initiated that may include an alarm and/or compensatory action which may include temporarily increasing the rate of pumping (step 2651) and the cycle will begin again at step 2611. If it is determined that no bubble is present, an alarm is triggered to indicate an undetermined fault condition (step 2671). Embodiments of the present invention may also utilize bubble detection using AVS technology as disclosed in co-pending US Patent Application, Serial No. 60/789,243, which is incorporated herein by reference.

30

The pumping assembly 16 of FIGS. 2A -3 urges fluid from the reservoir 20 to the dispensing assembly 120. When a dispensing assembly according to FIGS. 6-7 is used, it is not necessary to use a high precision pump, because the feedback provided from the dispensing assembly 120 to the pumping assembly 16 allows adjustment of the pumping assembly 16 based on exact measurements of the volume being delivered. The individual pumping pulses may be of sufficiently low volume to allow precise compensation based on the feedback. Many different pumping assembly 16 implementations can therefore be employed. Various possible embodiments of the pumping assembly 16 are described below.

FIGS. 13 and 14 schematically show alternate embodiments of some of the components in a fluid delivery device according to an embodiment of the invention. FIG. 13 shows a flow line 310 with a pumping assembly 16 having a pumping element 2100 located between an upstream one way valve 21 and a downstream one way valve 22. The pumping element 2100 may use an actuator to deform a portion of the flow line to generate pressure in the flow line 310. The upstream one way valve 21 inhibits retrograde flow from the pumping element 2100 toward a fluid source (not shown), while the downstream one way valve 22 inhibits retrograde flow from the volume-sensing chamber 120 to the pumping element 2100. As a result, fluid is driven in the direction of the exit assembly 17, which, in one embodiment, includes a high-impedance passage.

In an alternate embodiment shown in FIG. 14, the functions of the pumping element, i.e., generating pressure in the flow line 310, and the upstream one way valve 21 are performed by a combined valving pump 2200. Thus, the pumping assembly 16 in the FIG. 14 embodiment is made up of two components—the combined valving pump 2200 and the downstream one way valve 22—instead of the three components used in the FIG. 13 embodiment. Other embodiments of the pumping assembly 16 may be used. The combination of valving and pumping functions in valving pump 2200 may be accomplished by a variety of mechanisms, some of which are described below with reference to FIGS. 15A-16 and 22-56.

In many of the embodiments described below, the poppet for the inlet valve **21**, the poppet for the exit valve **22** and the pumping actuation member **54** are all either directly or indirectly (e.g., as in FIGS. 50-56) in communication with the fluid line **310** such that each of these elements are able to create or react to various fluid pressures. As noted above, the upstream and downstream valves—which may also be referred to herein as the inlet and exit valves—are one way valves. The valves can be volcano, flapper, check or duck-bill valves, amongst other types of one way valves, or other types of valves that bias the flow toward the device output. An example of volcano valves are disclosed in U.S. application No. 5,178,182 issued January 12, 1993 to Dean L. Kamen, and incorporated herein by reference.

In the embodiment shown in FIGS. 15A-15D, the pumping assembly includes both an inlet valve **21** and an exit valve **22**, each of which includes a fluid inlet, a fluid exit, and a moveable member (which is, for each valve, a portion of membrane **2356**). The pumping assembly also includes a pumping element **2100**. The pumping element is located downstream from the inlet valve **21** and upstream from the exit valve **22**. In the following description, the exit valve will be starting from the closed position, i.e., fluid is not flowing through the exit valve. However, at a time when the fluid presents enough pressure, the fluid pressure opens the exit valve by placing pressure on the membrane and the exit valve's poppet **9221** to open the valve, and the fluid can then flow through the exit valve **22**. The embodiment of FIGS. 15 A through 15D may be considered to be a combined valving-pump (like item **2200** in Fig. 14), in the sense that a single mechanical action both occludes a pump inlet and then urges flow through a pump outlet.

This pumping arrangement has the advantage of partitioning the moving parts and wetted line components to opposite sides of a flexible barrier membrane **2356**. As a result, the moving parts may be located in a reusable component and the wetted parts (fluidic line **310**) may be located in a disposable component.

In a preferred embodiment of the pumping mechanism, the fluid source is a non-pressurized reservoir. When the moveable member of the inlet valve is in the open position, and a negative pressure exists in the pumping chamber, a pressure  
5 differential exists that pulls the fluid from the reservoir towards the inlet valve. This negative pressure may be created by the resiliency of the membrane in the pumping chamber. In one alternative embodiment, a spring—which may be built into the membrane—may be used to assist in the recoil of the membrane in the pumping chamber. The non-pressurized reservoir may be collapsible, so that when fluid is  
10 drawn from it, a corresponding collapse in the reservoir reduces its volume. As a result, build-up of negative pressure, or air in the reservoir is prevented.

In a preferred embodiment of the pumping mechanism, after the inlet valve is closed, pressure is applied to the pumping chamber forcing fluid from the pumping chamber  
15 towards the exit valve. Pressure created by the pumping motion opens the exit valve and allows fluid to flow through the exit valve's fluid exit.

The moveable member can be anything capable of functioning as described above. In some embodiments, the moveable member is a flexible membrane or a resilient  
20 pumping diaphragm. In other embodiments, the moveable member is a ball-shaped rigid structure or another object capable of preventing fluid from flowing out of an opening in the fluid path.

In practice, the pumping mechanism may be primed prior to use. Thus, the pumping  
25 mechanism cycles through a number of strokes, purging air from the fluid line, until most or all of the air in the fluid line is purged. Many of the pumping mechanisms disclosed herein have the ability to “self-prime” because the fluid volume contained outside the pumping chamber, but between the valves, is small. When the pump squeezes air in the pump chamber, it generally builds up enough pressure to blow past  
30 the exit valve. The subsequent return stroke can therefore develop sufficient negative pressure for the pump to pull liquid from the reservoir. If the “dead” volume of the

pump is too large, the air in the pumping chamber may not build up enough pressure to escape the exit valve. As a result, the pump may stall.

FIGS. 15A-15D, 16 and 22-56 show several embodiments of the pumping mechanism. Referring now to FIGS. 15A-15D, one embodiment of the pumping mechanism is shown exemplifying several steps in the pumping process: 1. fluid passing through the inlet valve 21 (as shown in Fig. 15B); 2. the inlet valve closed (as shown in FIG. 15C); and 3. the pumping actuation member 54 forcing fluid downstream, with fluid pressure opening the exit valve 22 and flowing through the fluid exit (as shown in FIG. 15D).

The pumping mechanism of FIGS. 15A-15D includes a moveable member, which, in this embodiment, is a portion of the flexible membrane 2356. The inlet and exit valves include poppets 9221, 9222 that function as valve occluders. Each of the poppets 9221, 9222 and the pump actuation member 54 include a spring 8002, 8004, 8006. The pump plate 8000 is attached to both the pump actuation member 54 and the inlet poppet 9221 and serves as a terminus to their respective springs 8004, 8002.

The term "poppet" is used to denote a member that applies pressure against the moveable member (i.e., the membrane) to affect the position of the membrane. Although other designs may be used, some specific examples of spring-loaded poppet valves that utilize structures and principles of mechanical advantage are described below (in connection with FIGS. 50-56). . However, mechanisms other than poppets can be used to perform the same function. In FIGS. 15B-15D, the inlet valve 21 includes a fluid inlet and fluid exit, part of the membrane 2356, and a poppet 9221. The exit valve 22 includes a fluid inlet a fluid exit, part of the membrane and a poppet 9222.

In the embodiment shown in FIGS. 15A-15D, the fluid path 310 is defined by a structure (item 9310 in FIG. 15A), which may be rigid or have some flexibility (preferably less flexibility than membrane 2356. As shown in FIG. 15A, the housing

structure **9310** defines the valving chambers **9321**, **9322** and the pumping chamber **2350**; all three of these chambers are in the fluid path **310**.

5 Referring now to FIGS. 15B-15D, the inlet valve **21**, exit valve **22** and pump element **2100** each have a fluid inlet and a fluid exit. The pumping actuation member **54** has a pumping chamber **2350** where the fluid flows after exiting the inlet valve. Pumping actuation member **54** applies pressure onto the membrane **2356**, creating positive pressure in the fluid line.

10 As shown in FIGS. 15B-15D (and similarly for the valve seat **4070** for the outlet valve shown in FIGS. 50-56), the valve seat **9121** in the inlet valve **21** is preferably spaced away from the membrane **2356**, when the membrane is not being actuated by the poppet **9221** of the inlet valve.

15 The fluid line **310** is partially defined by a membrane **2356**. In this embodiment, the membrane **2356** separates parts of the pumping mechanism from the fluid. Thus, the fluid line **310** is wetted and the pumping actuator **54** and the valve poppets **9221**, **9222** are not wetted. However, alternative embodiments of the pumping assembly do not need to include a membrane **2356** that is in contact with the fluid line **310**.

20 Instead, a different moveable member may be used for the valves and/or pump. In still other embodiments, only parts of the fluid line **310** are separated from the pumping mechanism, thus partially wetting the pumping assembly.

25 The inlet poppet **9221** includes an end **8018** referring to the surface area of the inlet poppet that contacts the membrane portion of the fluid line **310**. The pumping actuation member **54** includes an end **8012** that contacts the membrane portion of the fluid line **310**. Likewise, the exit poppet **22** includes an end **8022** that contacts the membrane portion of the fluid line **310**. The ends **8018**, **8022** of the valve poppets apply pressure onto their respective areas of the membrane **2356**, blocking or  
30 unblocking the respective portions of the flow path **310**. The end **8012** of the



pressure actuation member also applies pressure onto its respective area of the membrane, so as to cause flow through the fluid line 310.

5 The pumping actuation member 54 is surrounded by a plunger biasing spring 8004. The plunger biasing spring 8004 has both a terminus at the pump plate 8000 and at 8014, a support structure that also holds the pumping actuation member.

10 The inlet poppet 21 is surrounded by an inlet poppet spring 8002, although in alternate embodiments, the inlet poppet itself is resilient and so serves the function of the spring. The inlet poppet spring 8002 has both a terminus at the pump plate 8000 and near the end 8018 of the inlet poppet 9221.

15 The exit poppet 9222 is surrounded by a passive exit poppet spring 8006. The exit poppet spring 8006 has both a terminus at an exit poppet plate 8024 and the lip 8020 near the end of the exit poppet 9222.

20 In each case, the springs 8002, 8004, 8006 terminate before the respective ends and do not interfere with the surface areas 8018, 8012, 8022 that contact the membrane 2356.

25 In a preferred embodiment, the fluid pumping device also includes at least one shape memory actuator 278 (e.g., a conductive shape-memory alloy wire) that changes shape with temperature. The temperature of the shape-memory actuator(s) may be changed with a heater, or more conveniently, by application of an electric current. FIGS. 15B-15D show an embodiment with one shape memory actuator 278, however, in other embodiments (described below) there may be more than one shape memory actuator 278. In one embodiment, the shape memory actuator is a shape memory wire constructed of nickel/titanium alloy, such as NITINOL™ or FLEXINOL®. However, in other embodiments, any device capable of generating a force, such as a solenoid, could also be used. In certain embodiments, the shape memory actuator 278 has a diameter of about 0.003 inches and is about 1.5 inches in length. However, in

other embodiments, the shape memory actuator **278** may be made from any alloy capable of contraction with heat (and expansion may be aided by a mechanism that imparts force on the alloy so as to stretch the alloy to the original length, i.e., a spring, although such a mechanism is not required) so as to actuate the pumping mechanism as described in the embodiments herein. In certain embodiments, the diameter of the shape memory actuator **278** can be from 0.001 inches to any diameter desired and the length can be any length desired. Generally speaking, the larger the diameter, the higher the available contraction force. However, the electrical current required to heat the wire generally increases with diameter. Thus, the diameter, length and composition of the shape memory alloy **278** may affect the current necessary to actuate the pumping mechanism. Irrespective of the length of the shape memory actuator **278**, the actuation force is approximately constant. Increase in actuation force can be imparted by increasing the diameter of the shape memory actuator **278**.

The shape memory actuator **278** connects to the pump plate **8000** through connector **8008**. Connector **8008** is described in more detail below. The shape memory actuator **278** connects to a fluid pumping device by way of terminus connector **8010**. Depending on the device or system in which the pumping mechanism is used, the terminus connection location will vary. The terminus connector **8010** is described in more detail below.

FIGS. 15B-15D show the pumping mechanism and fluid line **310** having already been primed as discussed above. Referring now to FIG. 15B, the inlet valve **21** is open, and the pumping actuation member **54** is not pressing against the membrane **2356**. The exit valve **22** is in the closed position. The shape memory actuator **278** is in an expanded position. In this configuration, fluid is pulled from a reservoir (not shown) to the inlet valve **21** fluid inlet. (Although shown as a bulge in the membrane in the inlet valve region, the pulling of fluid in this step may cause a depression in the membrane, or no deformation of the membrane). When the inlet poppet is in the open position, the fluid can flow from the fluid inlet to the fluid exit and into the pumping

chamber **2350**. At this point, the exit poppet end **8022** is firmly pressed against the membrane **2356** and seals the exit valve **22**.

Referring next to FIG. 15C, electrical current has been applied to the shape memory actuator **278**, and the shape memory actuator is contracting from a starting length  
5 towards the desired end length. The contracting of the shape memory actuator **278** pulls the pump plate **8000** towards the fluid line **310**. The inlet poppet **9221** and the pumping actuation member **54** are both connected to the pumping plate **8000**. The motion of the plate **8000** pulls both the inlet poppet **9221** and pumping actuation  
10 member **54** towards the membrane **2356**. As shown in FIG. 15C, the inlet poppet end **8018** is pressed firmly against the membrane **2356**, sealing the membrane against the valve seat **9121** and, closing the inlet valve **21**. (The motion of the inlet poppet can force a small amount of fluid in the inlet valving chamber, item **9321** in FIG. 15A, through either the fluid inlet or the fluid exit of the inlet valve **21**.)

15 Simultaneously, the pumping actuation member **54** begins its path towards the pumping chamber **2350**. During this process, as the inlet poppet spring **8002** is compressed (at this point, the inlet poppet end **8018** is pressing firmly against the fluid line **310**), the pump plate **8000** and pumping actuation member **54** continue  
20 traveling towards the fluid line **310**. The inlet poppet spring **8002** allows the pump plate **8000** to continue moving toward the fluid line **310** with the pump actuation member **54** even when the inlet poppet **9221** can not travel any further.

25 Referring now to FIG. 15D, the pumping actuation member **54** presses against the area of the membrane **2356** over the pumping chamber **2350** and the fluid is pumped so as to increase the pressure of the fluid in the pumping chamber **2350**. The exit poppet end **8022** remains pressing firmly (aided by the exit poppet spring **8006**) on the membrane **2356** sealing the fluid inlet and fluid exit of the exit valve **22** until the  
30 pressure from the fluid flowing from the pumping chamber **2350** forces exit valve **22** open. Upon reaching a sufficient pressure, the fluid exits through the fluid exit of the

exit valve **22**, thus overcoming the pressure exerted against the membrane **2356** by the exit valve **22**. Upon cessation of flow, the exit valve **22** is forced closed by the passive spring **8006**.

5 During the work stroke, the pump actuation member spring **8004** is loaded. Eventually, the pump actuation member spring **8004** will pull the pump actuation member **54** away from the membrane **2356**. As a result, during the relaxation stroke, the spring **8004** returns the pump actuation member **54**, and pumping plate **8000** to the relaxed position of FIG. 15C; the loaded inlet poppet spring **8002** may also  
10 contribute energy to the return stroke. As the pumping plate **8000** nears its relaxed position, it engages a cap of the inlet poppet **9221** to lift and unseat the inlet poppet so as to open the inlet valve **21**. The pump actuation member spring **8004** also unloads during the return stroke.

15 The pump plate **8000**, reaching a threshold distance where the inlet poppet spring **8002** is at the same level as the pump plate **8000**, will unload with the pump actuation member spring **8004**. The membrane **2356** in the pumping chamber **2350**, being resilient, will return to its starting position. This creates a negative pressure and as the inlet valve opens, fluid will flow through the inlet valve's fluid inlet to the fluid  
20 exit and towards the pumping chamber **2350**. Thus, the pumping mechanism will now be in the state as shown in FIG. 15B.

The entire pump sequence described with respect to FIGS. 15B-15D will repeat each time the pump is actuated through application of current onto the shape memory  
25 actuator **278**.

The membranes referred to herein, including membrane **2356**, may be made from any resilient material capable of imparting the necessary characteristics to function as described herein. Additionally, the membrane material may include a biocompatible  
30 material so as not to impede operation of the pump or diminish the therapeutic value of the fluid. Multiple biocompatible resilient materials may be suitable, including

nitrile and silicone. However, different therapeutic fluid compositions may require different choices of resilient material.

5 The pumping mechanism described above and also various embodiments as described herein can be described in terms of stroke length. One way to determine stroke length is by the total change in the length of the shape memory actuator during one cycle of contraction and expansion of the shape memory actuator. This difference will determine the total distance the pump rod travels and thus, the total amount of fluid that flows out of the inlet chamber 2354 to the pumping chamber 2350, to the exit chamber 2352 and finally, out the exit chamber 2352. Another way to determine stroke length is the travel distance of the pump plate 8000. For a partial stroke, the pump plate 8000 will not reach its maximum travel distance. In one embodiment, very small or micro-strokes are initiated continuously, pumping micro-liter volumes of fluid on a continuous or regular basis, from the reservoir to the exit. For example, 10 a micro-stroke may displace less than 20%, 10% or 1% of the volume of the pumping chamber 2350. 15

FIG. 16 shows a variation of the pumping mechanism embodiment shown in FIG. 15B. In FIG. 16, two different shape memory actuators—a longer one and a shorter one—are used. FIG. 16 shows an embodiment of the pumping mechanism shown in FIG. 15B in which the shape memory wire 278 is tensioned around a pulley 286 and splits into longer and shorter strands. A common juncture serving as a negative terminal may be located where the longer and shorter strands split off. Completion of a circuit with either or both of the alternate paths allows adjustment of the pumping force and/or stroke length. In an alternative embodiment, a piece of material, such as Kevlar material, extends from the common junction around the pulley to the force plate 8000, while two separate pieces of shape memory wire extend from the common junction to their respective supports. These embodiments provide both a pumping mode and an air purging mode, as described below, by using two wires with different 25 30 lengths.

With respect to varying stroke using the shape memory actuator variables, for a given length of shape memory actuator, the stroke is dependent on a number of variables: 1. total time electricity/heat is applied; 2. total voltage of the electricity; and 3. the diameter of the shape memory actuator. Some variable embodiments are shown in FIGS. 17-19. However, in some embodiments, the stroke can be varied while maintaining the length, electricity time and voltage. These embodiments include multiple shape memory actuators (see FIG. 19) and multiple switches on a single shape memory wire (see FIG. 17). As discussed above, the desired stroke length can also be attained by modifying any one or more of the variables.

Additionally, the timing of the application of heat or electric current to the shape memory actuation can vary to control the stroke. Each time the shape memory actuator is heated can be termed a pulse. Factors such as the pulse frequency, pulse duration, and stroke length may affect the amount of fluid delivered over time.

FIGS. 17-19 additionally depict embodiments of pumping assemblies which have both a fluid pumping mode and an air purging mode. When activated, the air purging mode applies a compression stroke of increased displacement and/or increased application of force by a force application member. The air purging mode may be activated based on the likelihood or knowledge of air being present in the pumping assembly. For example, the air purging mode may be activated when the line is attached to a reservoir, when a bubble is detected by a sensor or sensing apparatus, or when insufficient flow is detected by a sensor or sensing apparatus. Alternately, the two modes may be used to select between displacing a smaller and a larger volume of fluid for a given pumping pulse.

Referring now to FIG. 17, a schematic shows a pumping assembly actuated by a shape memory actuator 278 and having multiple modes of operation. When a pumping chamber 2350 is filled with fluid, the pumping assembly operates in a fluid pumping mode. During fluid pumping mode, electrical current flows between a negative electrical lead 2960 and a positive electrical lead 2961, causing resistive

heating of the alloy shape memory actuator 278 and a resultant phase change and power stroke. In one embodiment, during priming of the pumping mechanism or when a bubble 2950 is suspected to be in the pumping chamber 2350, the air purging mode is activated and electrical current flows along a path of extended length  
5 between a negative electrical lead 2960 and a positive electrical lead 2965; the result is a compression stroke of greater force on and displacement of force application member 2320 which should be sufficient to displace air 2950 from the pumping chamber 2350 to the pump outlet 2370. In alternate embodiments, the positive and negative leads may be reversed.

10

Referring now to FIG. 18, a schematic shows an alternate pumping assembly having a plurality of shape memory actuators 278 having the same length. The additional actuators may be used to increase the actuating pressure on the pumping chamber 2350, for example, to remove an occlusion or air bubble in the fluid line, pumping  
15 chamber or other area of the pumping mechanism. The additional actuators may also provide a redundancy to any pumping device. A single shape memory actuator may be capable of imparting sufficient force to remove an air-bubble from the pumping chamber. Additionally, in the embodiment shown in FIG. 18, an additional return spring may be necessary depending on the length of the second shape memory  
20 actuator.

20

When a reservoir is first attached to a flow line having a pumping assembly, the pumping mechanism (item 16 in FIGS. 13-14) is typically filled with air. Air can also enter the pumping mechanism during normal operation for various reasons.

25

Since air is more compressible than fluid, application of a compression stroke of a length that is sufficient to displace a fluid may be insufficient to generate enough pressure to overcome the cracking pressure of a one way valve of the pumping mechanism if there is a substantial amount of air in the fluid line. Accordingly, the pumping mechanism may stall. However, it may be desired to force air through the  
30 line during priming or when an innocuously small amount of air is present in the

30

pumping assembly. Thus, the embodiments shown in FIG. 18 can be used to impart additional force in this situation.

FIG. 19 schematically shows an alternative pumping assembly **16** having a plurality of shape memory actuators. A first, shorter, shape memory actuator **2975** has a first electrical lead **2976** and a second electrical lead **2977**. The shorter actuator **2975** is capable of generating compression strokes that are sufficient to displace fluid in the pumping chamber **2350**; the shorter shape memory alloy actuator **2975** is used during normal fluid pumping mode operations. When an air purging mode is indicated, or a larger pumped fluid volume is required, a second longer shape memory alloy actuator **2970** may be used by sending a current along an actuator length disposed between a first electrical lead **2973** and a second electrical lead **2972**. The longer shape memory alloy actuator **2970** may also be used as a backup actuator for fluid pumping mode operation by creating a shorter circuit which includes an electrical path between a first electrical lead **2972** and a second electrical lead **2971**. The shorter shape memory actuator **2975** may also be used to vary the stroke volume to provide better control at lower fluid volume rates. The multiple mode actuators of FIGS. 17-19 are not limited to use with the pump components shown and may be employed with any of the various embodiments of pumping mechanisms described herein including those using fluid pumping devices as described below and those employing valving pumps as described below. Thus, the desired stroke length can be initiated by applying electricity/heat to the length shape memory actuator that will provide the desired stroke length.

Referring now to FIGS. 20A and 20B, each shows one embodiment for attaching the shape memory actuator. These various embodiments can be used in any of the mechanisms or devices described herein which employ a shape memory actuator **278**. Referring to both FIG. 20A and FIG. 20B, the shape memory actuator **278** is fed into a grommet **280**. The grommet **280** is then attached to a part **284**. Although only two embodiments of this mode of attachment are shown, various other modes are used in



other embodiments. Other modes of attaching a grommet to a part or any fixed location can be used.

5 Referring now to FIGS. 21A and 21B, two exemplary embodiments of attaching the shape memory actuator 278 for use with a pumping mechanism 16 are shown. In each of these embodiments, the shape memory actuator 278 is designed to turn around a pulley 286. Referring to FIG. 21A, the shape memory actuator 278 is attached to a piece 288, preferably made of KEVLAR material, by way of grommet 280. One end of the shape memory actuator 278 is shown attached to a part 284 by 10 way of a set screw attachment 289. Referring now to FIG. 21B, one end of the shape memory actuator is shown attached to a part 284 by a grommet 280.

Various embodiments of the pumping mechanism are shown in herein. The pumping mechanisms may include an inlet valve, a pumping actuation member and an exit 15 valve. As discussed above, different types of one way valves may be used in alternative embodiments. Although the schematic shown in FIGS. 15A-15D shows one embodiment, the following figures show alternate embodiments.

20 Referring now to FIG. 22 and FIG. 23, a side view and a cross section of a section of a pumping mechanism is shown. In this embodiment, the pumping actuation member is a pumping elongate finger 32. When force is exerted onto the finger 32, the finger 32 depresses the moveable member and reduces the internal volume of the fluid line. The section of the pumping mechanism in FIGS. 22 and 23 shows only the pumping chamber. When combined with one way valves (items 21 and 22 of FIG. 13), 25 application of a deforming force to moveable member 23 urges fluid to flow toward an exit assembly (not shown). As shown in FIGS. 22 and 23, the finger 32 is pointed for focusing of force, but in other embodiments, the finger 32 may be flat, or of any other suitable shape. A spring 31 serves to bias the finger 32 toward a retracted position with respect to the resilient member 23 so that the finger 32 returns to the 30 retracted, non depressing position in the absence of application of force. As shown in FIG. 23, a motor can be used to apply force onto the finger 23. However, in other

embodiments, a shape memory actuator is used. Various types of motors will be suitable including electric motors and piezoelectric motors.

5 Referring to both FIGS. 22 and 23, a backstop 33 limits the potential travel of the finger 32, supports the moveable member 23, and ensures a reduction of volume in the fluid line or pumping chamber by preventing the moveable member 23 from moving out of position in response to application of force by the finger 32. As seen in FIG. 22, the backstop 33 may advantageously have a shape complementary to the resilient member 23. In various embodiments, the pumping assembly 16 may include  
10 a lever or crank driven on one end by a motor, compressing the resilient member 23 at another end.

Referring now to FIG. 24, another embodiment of the pumping actuation member is shown in relation to one section of the pumping assembly. A motor or shape memory  
15 actuator (not shown) applies a rotating force to a grouping of coupled projections 42. These projects 42 serve as the pumping actuation member and, in turn, apply force to the moveable member 23 in turn. Accordingly, intermittent pulses of force are applied to the moveable member 23. The backstop 33, as shown, can travel within a housing 44 and is upwardly biased toward the resilient member 23 by a spring 46.

20 Referring now to FIG. 25, an embodiment of a force application assembly with a pumping actuation member (here, a plunger) 54 inside a barrel 52 is shown. A motor causes the plunger 54 to be alternately withdrawn and inserted into the barrel. When the plunger 54 is withdrawn, a negative pressure draws fluid from the reservoir (not shown) into a channel 51 and a lumen 56. When the plunger 54 is inserted, the  
25 increased pressure in combination with the one way valves (not shown) drives fluid towards the dispensing assembly (not shown). The lumen 56 is connected to the channel 51 via a connecting channel 58 and the volume of the barrel lumen 56 decreases with the plunging action of the plunger 54 thereby urging fluid through the  
30 flow line 310.

FIGS. 26 and 27 show another embodiment where the pumping actuation member is a plunger 54. A force application assembly and a linear actuator, that includes a shape memory actuation 278, drive the plunger 54. In FIG. 26, a shape memory wire 278 is in a cool, expanded state and is attached to a first support 241 and a plunger attachment cap 244. The cap 244 is in turn attached to a biasing spring 243 which is in turn attached to a second support 242. When the wire 278 is in an expanded state, the biasing spring 243 is in a relaxed state. FIG. 27 shows the shape memory actuator 278 in a contracted state due to application of an electric current to the wire 278 and coincident heating. Upon contraction, a force is exerted on the cap 244 causing an inserting movement of a plunger 54 and a corresponding pumping action. In the contracted state, the biasing spring 243 is in a high potential energy state. Upon cessation of application of the electric field, the Nitinol wire 278 cools and expands again, allowing the biasing spring 243 to return the plunger 54 to its retracted state. As shown in FIG. 21A-21B, a shape memory actuator 278 may be wound around one or more pulleys.

FIGS. 28-30 show a variety of embodiments in which pumping is accomplished by a pumping actuation member 54 using a shape memory actuator 278 to compress a moveable member forming a pumping chamber. The pumping chamber is bounded by one way valves 21, 22. FIG. 28 shows an embodiment including a pumping mechanism where the pumping actuation member is a plunger 54 in a barrel 52. The mechanism also includes a lever 273, a fulcrum 274, and a shape memory actuator 278. A shape memory actuator 278 is held within a housing 298 and is attached at one end to a conductive support 279 and at the other end to a positive terminal 275 of a lever 273. The lever 273 is in turn attached at its center to a fulcrum 274 and at a second end to a plunger 54. An electric current is applied to cause current to flow through the terminal 275, the shape memory actuator 278, and the conductive support 279, thereby causing the shape memory actuator 278 to contract, causing lever 273 to pivot about the fulcrum 274 and effect withdrawal of the plunger 54. Cessation of the current allows cooling of the shape memory actuator 278, allowing it to expand. The return spring 276 acts via the lever 273 to return the plunger 54 to an inserted position

within the barrel 52. The return spring 276 is held in a housing 277. An o-ring 281 prevents leaking of fluid from the plunger 54-barrel 52 assembly. The insertion and withdrawal of plunger 54 causes fluid to flow through the flow line in a direction determined by the orientation of two check valves: a first one way valve 21 and a second one way valve 22. Any suitable backflow prevention device may be used, which include one way valve, check valves, duck bill valves, flapper valves, and volcano valves.

FIG. 29 shows another embodiment of a pumping mechanism having a plunger 54, a barrel 52, and a force application assembly that includes a shape memory actuator 278. However, this embodiment, unlike the embodiment shown in FIG. 28, does not include a lever. A shape memory actuator 278 is held within a housing 298 and is attached at one end to a conductive support 279 and at the other end to a plunger cap 244 by way of contact 275. The plunger cap 244 is attached to the plunger 54. Once ample electric current is applied through a contact 275, the shape memory actuator 278 contracts. This contraction causes a pulling on the plunger cap 244 to effect insertion of the plunger 54 into the barrel 52. Cessation of the current allows cooling and of the shape memory actuator 278, thereby allowing it to expand. Upon expansion of the wire, the return spring 276 acts to return the plunger 54 to a withdrawn position within the barrel 52. The return spring 276 is held in a housing 277. O-rings 281 prevent fluid from leaking plunger 54-barrel 52 assembly. The insertion and withdrawal of the plunger 54 causes fluid to flow through the flow line in a direction determined by the orientation of a first one way valve 21 and a second one way valve 22.

Referring now to FIG. 30, an embodiment of a pumping device using a plunger 54 and a barrel 52 is shown. In this embodiment, a shape memory actuator 278 in the form of a wire positioned in a shaft within the plunger 54 is used to impart force on the plunger. The shape memory actuator 278 extends from a plunger cap 272 through a shaft in a plunger 54 and through a channel 58 to a supporting base 299. O-rings 281 and 282 seal the plunger 54, barrel 52, and channel 58. Application of electrical

current to a first lead 258 and a second lead 257 causes heating of the shape memory actuator 278 which results in contraction of the shape memory actuator 278.

Contraction of the shape memory actuator 278 causes a downward force sufficient to overcome the upward bias of a return spring 276 to be exerted on the plunger cap

5 272, thereby driving the plunger 54 into the lumen 290 of the barrel 52. Expansion of the shape memory actuator 278 allows the return spring 276 to return the plunger 54 to a withdrawn position. The insertion and withdrawal of plunger 54 causes fluid to flow through the flow line in a direction determined by the orientation of a first one way valve 21 and a second one way valve 22.

10

An alternate embodiment of the pumping mechanism is shown in FIG. 31. The pumping actuation member is an assembly 101 that combines the functions of a reservoir and pumping mechanism. Under the command of a controller 501, a motor 25 drives a plunger 102 to create pressure in a reservoir 104, thereby forcing fluid

15 through a first one way valve 106. Fluid then enters the resilient dispensing chamber 122 of a volume sensing assembly 120 with a sensor 550, and to an exit assembly 17. An optional second one way valve 107 may be included. Feedback control between the sensor 550 and the motor 25 via the controller 501 assures the desired flow of fluid to the patient. The first one way valve 106 serves to prevent reverse flow of

20 fluid due to the resilient force of the dispensing chamber 122 of the volume sensing assembly 120 when the chamber is filled and extended. The second one way valve 107 serves to prevent reverse flow of fluid from the exit assembly 17 or patient 12 into the dispensing chamber 122. In this embodiment, the sensor 550 can immediately detect the volume in the dispensing chamber 122.

25

FIGS. 32 - 34 schematically show sectional views of a combined valving pump 2200. FIG. 32 shows the valving pump 2200 with a collection chamber 2345 and a pumping chamber 2350 in a resting position, prior to actuation; FIG. 33 shows the valving pump 2200 in an actuating state during a compression stroke; and FIG. 34 shows the pump in an actuated state at the end of a compression stroke. A pump inlet 2310 is in fluid communication with an upstream fluid source, such as a reservoir, and connects

30

to a first end of a channel 2360. The channel 2360 connects at a second end to the collection chamber 2345, which is in fluid communication with a diaphragm aperture 2390 disposed in a resilient pumping diaphragm 2340. The collection chamber 2345 is bounded on a first side by the resilient pumping diaphragm 2340 and on a second side by a resilient pumping membrane 2330. The pumping membrane 2330 may be made from, among other things, latex or silicone rubber. The downstream side of the diaphragm aperture 2390 opens into the pumping chamber 2350. During priming of the pump and between actuation cycles, fluid travels from a fluid source such as a reservoir, through the pump inlet 2310, the channel 2360, the collection chamber 2345, and the diaphragm aperture 2390, and then arrives in the pumping chamber 2350. A one way valve 22 prevents fluid from leaving the pumping chamber 2350 via a pump outlet 2370 until and unless ample fluid pressure is exerted against the one way valve 22 such that the one way valve 22 is open. In FIG. 32 a pumping actuation member 2320 is shown in a resting position, and the resilient pumping membrane 2330 is shown in a relaxed configuration of minimal surface area, thereby maximizing the volume of the collection chamber 2345. Although in this embodiment, the pumping actuation member is shown as a ball, in other embodiments, the pumping actuation member can be anything capable of actuation and applying ample force against the resilient pumping membrane 2330 in order to actuate the pumping mechanism.

As can be seen from FIG. 33, when the pumping actuation member 2320 is actuated during a compression stroke, the pumping actuation member 2320 begins to travel toward the diaphragm aperture 2390 of the resilient pumping diaphragm 2340 and distends the resilient pumping membrane 2330, causing retrograde flow of fluid that has collected in the collection chamber 2345. Later in the force application stroke, as shown in FIG. 34, the pumping actuation member 2320 will sealingly lodge the resilient pumping membrane 2330 against the diaphragm aperture 2390. To aid in sealing, the pumping actuation member 2320 may have a shape that is complementary to the shape of the diaphragm aperture 2390. For example, the pumping actuation member 2320 may be spherical or conical and the diaphragm

aperture **2390** may be a cylindrical through-hole. At this stage of the force application stroke, retrograde flow from the pumping chamber **2350** will be inhibited. Continued travel of the pumping actuation member **2320** will deform the resilient pumping diaphragm **2340** and increase the pressure in the pumping chamber **2350**, while continuing to seal the diaphragm aperture **2390** against retrograde flow from the pumping chamber **2350**. When the pressure within the pumping chamber **2350** provides ample fluid pressure against the one way valve one way valve **22**, fluid will flow from the pumping chamber **2350** through the pump outlet **2370**. During the return stroke, the pumping actuation member **2320**, resilient pumping membrane **2330** and resilient pumping diaphragm **2340** return to the relaxed positions shown in FIG. 32. During the return stroke, the internal pressure of pumping chamber **2350** and collection chamber **2345** will drop, which should encourage refilling of the valving pump **2200** by inducing flow of fluid from the fluid source through the pump inlet **2310** and channel **2360**.

Referring now to FIG. 35, a schematic sectional view of one embodiment of a resilient pumping diaphragm **2340** is shown. A diaphragm body **2515** may be constructed of a resilient material such as silicone rubber. A diaphragm spring **2510** may also be included to impart resiliency to a flexible, or already resilient, body **2515**. The diaphragm spring **2510** may be embedded within the resilient pumping diaphragm **2340** or disposed adjacent to the resilient pumping diaphragm **2340**. An example of one embodiment of a diaphragm spring **2510** can be seen in FIG. 36. A combination of a diaphragm body **2515** that includes a compliant material, and a diaphragm spring **2510** that includes a resilient material may be used; the result is a pumping diaphragm **2340** that will exhibit a high degree of sealing when contacted with the resilient pumping membrane **2330** deformed by a pumping actuation member (not shown, see FIGS. 32 – 34) and also have a high degree of resiliency. A valve seat **2517** may be positioned around the diaphragm aperture **2390**. The valve seat **2517** may function as a receptacle for the deformed portion of the resilient pumping membrane **2330**. The force application member **2320** may deform the pumping membrane **2330**, causing the membrane **2330** to deform and sealingly

contact the valve seat **2517**. If sufficient force is applied, the valve seat may be resiliently deformed to ensure a thorough seal against retrograde flow of fluid. The ratio of the section height to the section width of the valve seat **2517** can generally be selected differently and matched to the circumstances of the flow.

5

Now referring to FIG. 36, an example of a diaphragm spring **2510** for use in the pumping diaphragm **2340** of FIG. 35 is shown. An outer annulus **2520** and an inner annulus **2540** are connected by at least three resilient arms **2530**. The center of the inner annulus **2540** has a spring aperture **2550**, which may be aligned with the diaphragm aperture **2390** of the pumping diaphragm **2340** as shown in FIG. 35.

10

Referring now to FIG. 37, a schematic is shown representing a sectional view of the valving pump **2200** previously shown in FIGS. 32-34 in combination with a force application assembly which includes a pumping actuation member **2320**, an actuator, and a lever **273**. When energized by an actuator, such as a shape memory actuator **278**, the lever **273** pivots around a fulcrum **274** to initiate a compression stroke. A hammer **2630** protrudes from the lever **273**. During the compression stroke, the hammer **2630** contacts a rounded pumping actuation member **2320**, causing the pumping actuation member to travel within a void in a support structure **2660**, and pushing the pumping actuation member **2320** against a resilient pumping membrane **2330** until the pumping actuation member **2320** is held sealingly against a diaphragm aperture **2390** located in the resilient pumping diaphragm **2340**. As the lever **273** continues travel, the pumping actuation member **2320** causes deformation of a pumping diaphragm **2340**. When enough fluid pressure is exerted onto the one way valve **22**, the one way valve **22** opens. This allows the fluid to flow from a pumping chamber **2350** through a pump outlet **2370**. Upon cooling of the shape memory actuator **278**, the resiliency of the pumping diaphragm **2340** and the resilient pumping membrane **2330** will cause return of the lever **273** to a starting position determined by a lever stop **2650** and lever catch **2640**. Alternately, a return spring (not shown) may be used to return the lever **273** to the starting position. Although shown as a sphere,

15

20

25

30



the force application member **2320** may alternately be a piston, a protrusion of the lever **273** or other suitable form.

FIG. 38 schematically shows a sectional view of an embodiment of a valving pump using a resilient cylindrical flexure **2670**. In one embodiment, the resilient cylindrical flexure is made from rubber, but in other embodiments, it can be made from any resilient material. The cylindrical flexure **2670** has a central passageway **2675**, and a plurality of resilient radial fins **2672** that are sealingly arranged against a housing **2673**. Fluid entering through a pump inlet **2310** passes through a channel **2360** and collects in regions upstream of a one way valve **22**: a collection chamber **2345**, the central passageway **2675** of the cylindrical flexure **2670**, and a pumping chamber **2350**. The pumping chamber is coupled in fluid communication with the collection chamber **2345** through the central passageway **2675**. During the pumping mechanism's compression stroke, a pumping actuation member **2320** applies force to, and deforms, a resilient pumping membrane **2330** until the resilient pumping membrane **2330** is sealingly held against a valve seat **2680** of the cylindrical flexure **2670**; retrograde flow to the pump inlet **2310** from the collection chamber **2345** is thereby blocked. Continued travel of the pumping actuation member **2320** causes deformation of the cylindrical flexure **2670**; the pressure within the pumping chamber **2350** increases until such time that it is ample to open the one way valve **22**. Fluid can then flows through a pump outlet **2370**.

The pumping actuation member **2320** is shown as a ball shape in FIG. 38. However in other embodiments, the pumping actuation member **2320** can be any shape that can function as described above.

Referring now to FIG. 39, an alternate embodiment of the cylindrical flexure **2670** (shown in FIG. 38) employing a resilient portion **2680** and a rigid cylindrical support **2690** is shown. Like the cylindrical flexure **2680** of FIG. 38, the resilient portion of the cylindrical flexure **2670** includes a valve seat **2680** which seals the central passageway **2675** upon application of force by a pumping actuation member **2320**.

Thus, the resilient portion **2680** of the cylindrical flexure **2670** deforms to transmit pressure to the pumping chamber **2350**.

FIGS. 40-44 schematically show sectional views of an alternate embodiment of a valving pump in various states of actuation. The valving pumps **2200** of FIGS. 40-44 have a resilient diaphragm spring **6100** and a resilient sealing membrane **6120** which together serve a function that is similar to that of the resilient pumping diaphragm **2340** of the valving pump **2200** shown in FIGS. 32-34. FIG. 40 shows the valving pump **2200** in a resting state. In the resting state, fluid may flow from the inlet **2360**, into an upper portion **2346** of the collection chamber **2345**, through an aperture **6110** in the diaphragm spring **6100** and into a lower portion **2347** of the collection chamber **2345**. Fluid then may proceed through one or more openings **6130** in a sealing membrane **6120** and into the pumping chamber **2350**. Under low-pressure conditions, further fluid flow is hindered by a one way valve **22**. The spring diaphragm **6100** and sealing membrane **6120** may both be constructed from resilient, biocompatible materials. The spring diaphragm **6100** may have a greater resiliency than the sealing membrane **6120**. For example, the spring diaphragm **6100** may be a circular piece of flexible bio-inert plastic and the sealing membrane **6120** may be a sheet of silicone or fluorosilicone elastomer.

FIGS. 41 and 42 show the valving pump **2200** in two intermediate, partially actuated states. The pumping actuation member **2320** deforms the pumping membrane **2330** and forces it through the collection chamber **2345** and against the spring diaphragm **6100**, which, in turn, is deformed and forced against the sealing membrane **6120**. At this point in the compression stroke, retrograde flow through either the aperture **6110** of the spring diaphragm **6100**, or through openings **6130** in the sealing membrane **6120**, or both, are suppressed. Offset placement of the sealing membrane openings **6130** relative to the spring aperture **6110** allows a seal to be created between the spring diaphragm **6100** and the sealing membrane **6120**. In some embodiments this seal may be supplemented with a redundant seal between the fill chamber resilient pumping membrane **2330** and the spring diaphragm **6100** (the embodiments of FIGS.

43-44, for example, lack this redundant seal). A circumferential ridge (not shown) around the spring diaphragm aperture **6110** may act as a valve seat to enhance the seal.

5 Referring now to FIG. 42, continued travel of the pumping actuation member **2320** causes further deformation of the pumping membrane **2330**, spring diaphragm **6100**, and sealing membrane **6120**. As a result, fluid in the pumping chamber **2350** is compressed until the fluid pressure forces the one way valve **22** open; further compression causes fluid egress through the outlet **2370**.

10

An alternate embodiment of the valving pump **2200** of FIGS. 40-42 is shown schematically in FIG. 43. In this embodiment, a pumping actuation member **2320** traverses the resilient pumping membrane **2330**. The pumping membrane **2330** is sealingly attached to the circumference of the pumping actuation member **2320** at a midpoint along the length of the pumping actuation member **2320**. When actuated, 15 the diaphragm spring aperture **6110** is sealed against backflow by the sealing membrane **6120** alone; the resilient pumping membrane **2330** will not contact the aperture **6110**. An alternate embodiment of the device shown in FIG. 40 is shown in FIG. 44.

20

Referring now to FIG. 45, a sectional view of an alternate embodiment of a combined valving pump **2200** is shown. A shape memory actuator **278** actuates a compression stroke which causes a resilient pump blade **2710** to lever about a fulcrum **274**, causing the resilient pumping membrane **2330** to be deformed. The resilient pump 25 blade **2710** and resilient pumping membrane **2330** apply pressure to fluid in a graded pumping chamber **2720** having a shallow region **2730** and a deeper region **2740**. Early in the compression stroke, the pump blade **2710** induces the resilient pumping membrane **2330** to obstruct a channel **2360** that connects a pump inlet **2310** to the graded pumping chamber **2720**. As the compression stroke continues, force is 30 applied to the fluid in the graded pumping chamber **2720** until the fluid pressure in the graded pumping chamber **2720** is great enough to open a one way valve **22**. Fluid

then exits a pump outlet **2370**. The pump blade **2710** may be constructed entirely or partly from a resilient material such as rubber. In some embodiments, the resilient material includes a non-resilient spline. Alternately, in some embodiments, the resiliency is imparted through a resilient region **2750**, thus, the resilient region **2750** is the only resilient part of the pump blade **2710** in these embodiments. In these  
5  
embodiments, the resilient region **2750** contacts the bottom of the graded pumping chamber **2720**. The resiliency of pump blade **2710** allows the compression stroke to continue after the pumping blade **2710** contacts the base **2780** of the shallow region **2730**. A return spring (not shown) returns the pump blade **2710** to a starting position  
10 during the return stroke.

Referring now to FIG. 46, a sectional view of an alternate embodiment of a pumping mechanism is shown. This embodiment includes a resilient pump blade **2710**. The resilient pump blade **2710** includes a resilient region **2830** which provides resiliency  
15 to the pump blade **2710**. The resilient region **2830** joins a pumping actuation member **2820** to a pump blade **2810**. When used with a valving pump (not shown) the resilient pump blade **2710** of FIG. 42 will occlude the inlet channel (not shown, shown in FIG. 45 as **2360**) and then bend at the flexible region **2830** to allow the force application member **2820** to apply further pressure to the fluid in the graded  
20 pumping chamber (not shown, shown in FIG. 45 as **2720**). The force application member **2820** may be constructed entirely of a resilient material such as rubber. However, in alternate embodiments, only a region that contacts the bottom of the pumping chamber (not shown) is made from resilient material. The resilient pump blade **2710** will return to its relaxed conformation during the return stroke.

25 Referring now to FIG. 47, a sectional view of another embodiment of pumping mechanism is shown. The pumping mechanism is shown where the lever is at the intermediate stage of actuation with the inlet valve **2941** closed. The pumping mechanism includes a fluid line **2930**, a moveable member **2330**, which is a  
30 membrane in this embodiment, an inlet valve **2941** poppet **2940**, a pumping actuation member **2942**, a pumping chamber **2350**, and an exit valve **22**. The inlet valve **2941**

and the pumping actuation member 2942 are each actuated by the shape memory actuator 278 which is surrounded by return spring 276 and connected to a lever 273. The lever 273 actuates both the inlet valve 2941 and the pumping actuation member 2942. The lever 273 includes an elongate and spring member 2910 that is attached to the lever 273 hinged to fulcrum 274 and terminated in a valve actuation hammer 2946. The spring member 2910 may be curved. The spring member 2910 biases the position of the valve actuation hammer 2946 away from the lever 273 and toward the inlet valve 2941. The lever 273 has a pump actuation hammer 2948, which is not attached to the spring member 2910, and is positioned adjacent to the pumping actuation member 2942.

Electric current causes the shape memory actuator 278 to contract and the lever 273 pivots about the fulcrum 274. The pivoting places the valve actuated hammer 2946 in position to force the inlet valve 2941 closed. As the shape memory actuator 278 continues to contract, the lever 273 continues pivoting and the pump actuation hammer 2948 forces the pump actuation member 2942 against the pumping chamber 2350, even while further compressing the elongate spring member 2910. Upon achieving sufficient pressure, the fluid pressure opens the exit valve 22, and fluid exits through the valve.

During the relaxation stroke, the return spring 276 unloads and returns the lever 273 to the starting position, releasing the pumping actuation member 2942. The inlet valve 2941 opens. The resiliency of the pumping chamber 2350 causes the pumping chamber 2350 to refill.

Referring now to FIGS. 48 and 49 schematically show a cross section of an embodiment in which a pumping mechanism employs a bell crank 7200 and combines a valving pump 2200 with a flow biasing valve. The bell crank 7200 converts force produced by the linear shape memory actuator 278 into a transverse pumping force. FIG. 48 shows the mechanism in a resting or refilling mode and FIG. 49 shows the mechanism in an actuated state. Contraction of the actuator 278

causes the bell crank **7200** to rotate around a shaft **7210** and press upon the force application member **2320**, which drives a resilient membrane **7220** to seal against the resilient pumping diaphragm **2340** and urge fluid from the pumping chamber **2350** toward the dispensing chamber **122**. The return spring **276** cooperates with a return spring support **7221** to release the pumping force, causing the pumping chamber **2350** to expand and draw fluid from the reservoir **20**. Still referring to FIGS. 48 and 49, the flow biasing valve **4000** is also shown, having a valve spring **4010**, a poppet or plunger **4020**.

In some of the embodiments of the pumping mechanism described above, one or more aspects of the following valving operation description is relevant. Referring now to FIG. 50, an example of a flow biasing valve **4000** is shown, closed. A valve spring **4010** exerts force on a poppet **4020** to sealingly press a valve membrane **4060** against a valve seat **4070** surrounding a terminal aperture of a valve outlet **4040**. The valve seat **4070** may include a circumferentially raised portion to improve sealing. As explained below with references to FIGS. 54-55, back pressure created by the action of a resilient dispensing assembly should be insufficient to cause retrograde flow through the flow biasing valve **4000**. As shown in FIG. 51, when the pumping assembly is actuated, sufficient pressure should be generated to unseat the membrane **4060** and the poppet **4020** from the valve seat **4070** thereby allowing fluid to flow from the valve inlet **4030**, through an inlet chamber **4050** and to the valve outlet **4040**. FIGS. 52-53 shows an alternate valve that has a valve seat **4070** without a circumferentially raised portion.

Referring now to FIGS. 54 and 55, illustrations of how an exemplary flow biasing valve discriminates between forward and retrograde flow are shown. FIG. 54 schematically represents the valve in a closed position. Back pressure in the outlet **4040** applies force to a relatively small area of the flexible valve membrane **4060** adjacent to the valve seat **4070** and is thus unable to dislodge the poppet **4020**.

Referring now to FIG. 55, this FIG. schematically represents the valve during the actuation of a pumping actuation member. The pressure of the pumped fluid applies

force over an area of the membrane **4060** that is larger than the area adjacent to the valve seat. As a result, inlet pressure has a larger mechanical advantage for unseating the poppet **4020** and forward flow should ensue in response to the action of the pumping actuation member. Thus, the critical pressure needed to displace the poppet **4020** is lower in the inlet than in the outlet. Accordingly, the spring biasing force and the size of the force application areas associated with both the fluid inlets and fluid exits may be chosen so that flow is substantially in the forward direction.

Referring now to FIG. 56, a sectional view of an adjustable flow biasing valve **4130** which operates on a principal similar to the flow biasing valve in FIG. 50, but allows adjustment of the pressure necessary to open the valve, i.e., “cracking pressure” (which, in some embodiments, can be from 0.2 to 20 pounds per square inch or “psi”) is shown. The cracking pressure is adjusted by turning a spring tensioning screw **4090**, which alters the volume of the recess **4080** to compress or decompress the valve spring **4010** thereby altering the spring **4010** biasing force. The valve spring **4010** biases a plunger **4100** against the valve membrane **4060** to force it against the valve seat. The plunger **4100** serves a force application function similar to the fixed force poppet of the flow biasing valve (shown as **4020** and **4000** respectively, in FIGS. 50-53). Compressing the valve spring **4010** will increase its bias, thereby increasing the cracking pressure. Conversely, decompressing the spring **4010** will decrease its bias and the associated cracking pressure. The valve spring **4010** is positioned coaxially around the shaft of a plunger **4100** and exerts its biasing force on the plunger **4100**. In some embodiments, the shaft of the plunger **4100** may be shorter than both the length of the valve spring **4010** and the recess **4080** to allow it to be freely displaced in response to increased fluid pressure in the fluid inlet **4030**. The plunger **4100** may be any size necessary to function as desired. As in the embodiment of FIGS. 50-53, the wetted parts may reside in a disposable portion **2610** and the force application components (e.g., the plunger and spring) may reside in the reusable portion **2620**. The principal of operation is also similar; a larger mechanical advantage in the fluid inlet **4030** relative the outlet **4040** favors forward flow versus retrograde flow. Alternately, the plunger **4100** may be replaced by the poppet (shown

as 4020 in FIGS. 50-55). In some embodiments, it may be desirable to eliminate the raised valve seat; in these embodiments, the plunger may be ball shaped or another shape capable of concentrating the force.

5

The flow biasing valve 4000 substantially reduces or prevents retrograde flow from the dispensing chamber 122 into the pumping chamber 2350. As in FIGS. 50-56, a valve spring 4010 biases a poppet or plunger 4040 to press the membrane 7220 against a valve seat 4070 in a way that provides mechanical advantage to forward flow through the line 310. By serving the function of the pumping membrane 2330 and the valve membrane, membrane 7220 allows the line 310, pumping chamber 2350 and pumping diaphragm 2340 to reside in one component (e.g., the disposable portion 2610) and the remainder of the pumping mechanism in a second, removable component (e.g., the reusable portion 2620). By placing the more durable and expensive components in the reusable portion 2620, economy and convenience may be realized.

10  
15

The pumping mechanism described in the various embodiments above can be used in various devices to pump fluid. As an exemplary embodiment, the pumping mechanism described in FIGS. 59A-59E, FIGS. 60A-60D and FIGS. 60A-60C will be described as integrated into a fluid pumping device.

20

Referring FIGS. 57 and 58, alternate ways are shown for the fluid schematic. These are two schematics where the reservoir 20 and pumping assembly 16 are coupled to the dispensing assembly 120. In the embodiment shown in FIG. 57, the reservoir and pumping assembly are coupled in series to the dispensing assembly 120. In the embodiment shown in FIG. 58, a shunt line 150 is coupled from the output of the pumping assembly 16 back to the reservoir 20. Since much of the fluid output of the pumping assembly 16 is returned to the reservoir 20 via the shunt line 150, the pumping assembly 16 can accommodate varieties of pumping mechanisms 16 that may not function as desired in the embodiment shown in FIG. 57. Thus, in some

25  
30



embodiments, where a large volume pumping mechanism is employed, the shunt line 150 can impart small volume functionality to a large volume pumping mechanism. One way valves 21 and 22 are oriented in the same direction and included to prevent unwanted backflow.

5

Referring now to FIG. 59A, a fluid schematic of one embodiment of a fluid pumping device is shown. In this embodiment, fluid is located in a reservoir 20 connected to a fluid line 310. Fluid line 310 is in communication with pumping mechanism 16, separated by a membrane 2356. The fluid is pumped through a flow restrictor 340 to an infusion device or cannula 5010 for delivery to a patient. It should be understood that the infusion device or cannula 5010 is not part of the device as such, but is attached to a patient for delivery of the fluid. System embodiments are described in more detail below and these include an infusion device or cannula 5010.

10

15

Referring now to FIG. 59B, an alternate embodiment of the schematic shown in FIG. 59A is shown. In the embodiment shown in FIG. 59A, the fluid is pumped through a flow restrictor 340 then through a cannula 5010. However, in FIG. 59B, the fluid is not pumped through a flow restrictor; rather, the fluid is pumped, having the same impedance, through the cannula 5010.

20

In both FIGS. 59A and 59B, the volume of fluid pumped to the patient, in one embodiment, is calculated roughly by pump strokes. The length of the stroke will provide for a rough estimate of the volume pumped to the patient.

25

Referring now to FIG. 59C, a fluid schematic of one embodiment of a fluid pumping device is shown. In this embodiment, fluid is located in a reservoir 20 connected to a fluid line 310 by a septum 6270. Fluid line 310 is in communication with pumping mechanism 16, separated by a membrane 2356. The fluid is pumped to a variable volume delivery chamber 122 and then through a flow restrictor 340 to a cannula 5010 for delivery to a patient.

30

The volume of fluid delivered is determined using the dispensing assembly **120** which includes an acoustic volume sensing (AVS) assembly, as described above, a variable volume delivery chamber **122**, and a dispensing spring **130**. Similarly to the pumping mechanism, a membrane **2356** forms the variable volume dispensing chamber **122**.

5 The membrane is made of the same material (or, in some embodiments, different material) from the membrane **2356** in the pumping mechanism **16** (described in detail above). The AVS assembly is described in greater detail above.

10 Referring now to FIG. 59D, an alternate embodiment to the embodiment shown in FIG. 59C, in this embodiment, there is no flow restrictor between the variable volume delivery chamber **122** and the cannula **5010**. Referring now to FIG. 59E, an alternate embodiment to the embodiment shown in FIG. 59C is shown, with an alternate pumping mechanism **16**.

15 Referring now to FIGS. 59A-59E, the reservoir **20** can be any source of a fluid, including but not limited to a syringe, a collapsible reservoir bag, a glass bottle, a glass vial or any other container capable of safely holding the fluid being delivered. The septum **6270** is the connection point between the fluid line **310** and the reservoir **20**. Various embodiments of the septum **6270** and the reservoir **20** are described in  
20 more detail below.

The fluid delivery device embodiment shown in FIGS. 59A-59E can be used for the delivery of any type of fluid. Additionally, the embodiments can be used as one, two or three separate mating parts. Referring now to FIGS. 60A-60D, the same  
25 embodiments described with respect to FIGS. 59A-59D are shown as separated into mating parts. Part X includes the movable parts while part Y includes the fluid line **310** and the membrane **2356**. In some embodiments of this design, part Y is a disposable portion while part X is a non-disposable portion. Part X does not come into contact directly with the fluid, part Y is the only part having wetted areas. In the  
30 above embodiments, the reservoir **20** can any size and is either integrated into the disposable or a separate disposable part. In either embodiment, the reservoir **20** can

be refillable. In embodiments where the reservoir 20 is integrated into the disposable part Y, the reservoir 20 can either be manufactured filled with fluid, or, a patient or user fills the reservoir 20 using a syringe through the septum 6270. In embodiments where the reservoir 20 is a separate mating part, the reservoir 20 can either be  
5 manufactured filled with fluid, or, a patient or user fills the reservoir 20 using a syringe (not shown) through the septum 6270 as part of a reservoir loading device (not shown, described in more detail below) or manually using a syringe through the septum 6270. Further detail regarding the process of filling a reservoir 20 is described below.

10 Although various embodiments have been described with respect to FIGS. 59A-59E and FIGS. 60A-60D, the pumping mechanism can be any pumping mechanism described as embodiments herein or alternate embodiments having similar function and characteristics. For example, referring now to FIG. 61A, a similar embodiment  
15 as that shown in FIG. 59A is shown having a representative block that includes pumping mechanism 16. This is to show that any pumping mechanism 16 described herein or functioning similarly can be used in the fluid pumping device. Likewise, FIG. 61B and FIG. 61C are representations of systems encompassing the embodiments FIG. 59B and FIG. 59C respectively.

20 The schematics of a fluid pumping device described above can be implemented in a device usable by a patient. There are a number of embodiments. The device can be a stand-alone device or be integrated into another device. The device can be any size or shape. The device can be either portable or non-portable. The term "portable" means  
25 a patient can, transport the device either in a pocket area, strapped to the body, or otherwise. The term "non-portable" means that the device is in a healthcare institution or in the home, but the patient does not carry the device almost everywhere they move. The remainder of this description will focus on portable devices as the exemplary embodiment.

With respect to portable devices, the device can be worn by a patient or carried by a patient. In the embodiments where the device is worn by a patient, this is referred to as a “patch pump” for purposes of this description. Where the device is carried by a patient, this is referred to as a “portable pump” for purposes of this description.

5

The following description is applicable to various embodiments for either the patch pump embodiments or the portable pump embodiments. In various embodiments, the device includes a housing, a pumping mechanism, a fluid line, a moveable member, a reservoir, a power source and a microprocessor. In various embodiments, a dispensing assembly, for example a volume sensing device, which in some  
10 embodiments includes an AVS assembly, are included in the device. Also, an embodiment can also include a fluid restrictor, although it is not depicted in the following figures, as the fluid line is shown as homogeneous to simplify the illustration. For purposes of this description, where a dispensing assembly is included, the exemplary embodiment will include an AVS assembly. Although an  
15 AVS assembly is a preferred embodiment, in other embodiments, other types of volume sensing device can be used. In some embodiments, however, no volume sensing device is used, but rather, either the reservoir itself will determine the volume of fluid delivered, the pump stroke is used to roughly determine the amount of volume delivered. It should be understood that the schematic devices shown herein are meant to illustrate some of the variations in the device. The embodiments represented by these schematics can each also include a sensor housing, a vibration motor, an antenna, a radio, or other components that are described with respect to FIGS. 70-70D. Thus, these depictions are not meant to limit the components but  
20 rather to illustrate how various components could interrelate in a device.

25

Referring now to FIG. 62A, schematics of a stand alone device 10 are shown. The housing 10 can be any shape or size and accommodates the intended use. For example, where the device is used as a patch, the device will be compact enough to be worn as such. Where the device is used as a portable pump, the device will be  
30 compact enough to be used accordingly. In some embodiments, the housing is made

from plastic, and in some embodiments, the plastic is any injection molded fluid-compatible plastic, for example, polycarbonate. In other embodiments, the housing is made from a combination of aluminum or titanium and plastic or any other material, in some embodiments the materials are light and durable. Additional materials may include, but are not limited to, rubber, steel, titanium, and alloys of the same. As shown in FIG. 62A, the device **10** can be any size or shape desired.

FIGS. 62A – 69B are schematics showing representative embodiments. The exact design is dependant on many factors, including, but not limited to, size of the device, power restrictions and intended use. Thus, FIGS. 62A – 69B are intended to describe the various features of a device and the possible combinations, however, actual devices can be readily designed and implemented by one of ordinary skill in the art. As examples, embodiments of devices are described and shown below. However, these are not intended to be limiting, but rather, are intended to be examples.

Referring now to FIG. 62B, with respect to the patch device, in some embodiments, the housing **10** includes an insertion area viewing window **342**. This allows for the area on a patient where the infusion device or cannula (not shown) is inserted to be viewed. Shown here is the cannula housing **5030** area of the device **10**. The viewing window **342** is made from any material capable of being transparent, including, but not limited to, plastic. Although the viewing window **342** is shown to be in one particular location on one particular shaped device, a viewing window **342** can be integrated in any location desired in any housing embodiment.

Referring now to FIG. 63A, a device **10** is shown. A reservoir **20** is shown connected to a fluid line **310**, which is then connected to a pumping mechanism **16**. A dispensing assembly **120** is shown connected to the fluid line **310**. The pumping mechanism **16** and dispensing assembly **120** are separated from the fluid line **310** by a membrane **2356**. The cannula housing **5030** is downstream from the volume measuring device. Shape memory actuators **278** are shown connected to the pumping mechanism **16**. A microprocessor on a printed circuit board **13** as well as a power

source or battery **15** are included. A flow impedance as described above can also be implemented between the dispensing assembly **120** and the cannula housing **5030**.

Referring now to FIG. 63B, a similar device **10** as shown in FIG. 63A is shown,  
5 except in this embodiment, a dispensing assembly is not included. In this  
embodiment, the volume of fluid delivered will depend on either the pump strokes  
(number and length), the reservoir **20** (volume and time), both, or any other method  
described previously with respect to monitoring the volume of fluid delivered.

10 Referring now to FIG. 63C, a similar device **10** as shown in FIG. 63B is shown,  
except the device **10** includes a dispensing chamber **122** and sensor housing **5022**.

Referring now to FIG. 64A, one embodiment of the patch pump device **10** is shown.  
This embodiment is based on the embodiment of the device **10** shown in FIG. 63A.

15 In this embodiment, the patch pump device **10** is divided into two sections: a top **X**  
and a base **Y**. The top **X** contains the pumping mechanism **16**, a dispensing assembly  
**120** (which is optional, but is shown as an exemplary embodiment), the power supply  
**15**, and the microprocessor and printed circuit board **13**. These are the non-wetted  
elements, i.e., they do not come into direct contact with the fluid. The base **Y**  
20 contains the fluid line **310** and the membrane **2356**. Where the reservoir **20** is built  
into the device, the reservoir is also contained on the base **Y**. However, in  
embodiments where the reservoir **20** is a separate mating part, the reservoir **20** is  
connected to the fluid line when fully assembled (see FIG. 66A-66D and description  
referring thereto), however, is not built into the device.

25 The patch pump device also includes a cannula housing **5030**. This is the area the  
cannula line **5031** is located. Part of the fluid line **310**, the cannula line **5031** allows a  
cannula (or other infusion device) to receive the fluid and deliver the fluid to a patient  
(not shown).

30

Referring now to FIG. 65A, in some embodiments, the cannula **5010** is inserted through the housing **5030** directly into the patient. The cannula **5010** is connected to a septum (not shown) connecting the cannula line **5031** to the cannula **5010**.

5 Referring now to FIG. 65B, in other embodiments, an insertion set, (including the cannula and tubing, not shown in FIG. 65B, but shown in FIG. 64B as items **5033** and **5010**) is used; thus, the tubing **5033** of the insertion set will connect to the cannula line **5030** on one end and will connect to the cannula (not shown) on the opposite end of the tubing.

10 Referring again to FIG. 64A, in use, the reservoir **20**, having fluid contained inside (which, as described above, is either molded into the base **Y** or is separate and attached to the base **Y**) is connected to the fluid line **310**. The microprocessor on the printed circuit board **13** sends a signal to activate the pumping mechanism **16** and a stroke is initiated through electrical current being applied to the shape memory  
15 actuators **278**. The fluid flows from the reservoir **20**, in the fluid line **310** to the dispensing assembly **120**, or AVS assembly. There, the exact volume of fluid inside the AVS chamber is determined and the fluid is forced out of the AVS chamber, to the cannula line **5031** and the cannula housing **5030**.

20 Referring now to FIG. 64B, the device shown in FIG. 64A is shown connected to an insertion set, tubing **5033** and cannula **5010**. In FIG. 64C, the base **Y** of the device is shown using an adhesive patch or pad **3100** to the body of a patient **12**. It should be noted that in this embodiment, the element **3100** can be either a pad or patch. However, as described in more detail below, item **3100** is called a patch, and item  
25 **3220** is called a pad. For simplicity purposes only, item **3100** is used; however, in some embodiments, a pad is used, thus item **3220** would be appropriate in those circumstances.

30 The cannula **5010**, which is inserted through the cannula housing **5030** so that it mates by way of the cannula septum **5060** to the cannula line **5031**, is inserted into a patient **12**. However, as shown and described above with respect to FIG. 2B, the base

Y can be fluidly attached to a patient through an insertion set, which includes a tubing 5033 and a cannula 5010. In both FIGS. 64B and 64C, the base Y can be adhered to a patient either before or after insertion of the cannula 5010. Referring again to FIG. 2C, the cannula 5010, once inserted into to the patient 12, will receive fluid from the device directly without an infusion set tubing (shown in FIG. 64B). The base Y is adhered to the patient 12 with an adhesive patch 3100 either before or after insertion of the cannula 5010. Referring now to FIG. 64D, the top X of the device 10 is then attached to the base Y of the device 10 after the cannula 5010 has been inserted into the patient 12.

As described below, the adhesive patch can have many embodiments and in some cases, the patch is placed on top of the device. Thus, the patch shown in these embodiments is only one embodiment. As described above, a pad, if used, would be placed in the same location as the patch in FIGS. 64A-64D.

Referring now to FIGS. 66A-66D, in this embodiment, the reservoir 20 is shown as a separate part. As shown in FIG. 66A, the base Y includes a reservoir cavity 2645 with a septum needle 6272. Shown in FIG. 66B, the reservoir 20 is first placed in a top reservoir cavity 2640. At this point, the reservoir 20 is not attached to the device. Now, referring to FIG. 66C, when the top X is placed over the base Y, the reservoir 20 is sandwiched into the base reservoir cavity 2645. Shown in FIG. 66D, the force created by the attachment of the top to the base Y push the septum needle 6272 into the septum 6270 of the reservoir 20 connecting the reservoir 20 to the fluid line 310 of the base Y.

Referring now to FIGS. 67A-F, alternate embodiments of the embodiments shown in FIGS. 64A, 64C and 66A-66D are shown. In these alternate embodiments, in addition to a cannula housing 5030, the base Y includes a sensor housing 5022. Referring now to FIGS. 69A-69B, both the sensor housing 5022 and the cannula housing 5030 include an exit to the underside of the base Y, shown in FIG. 69A as 5022 and 5030 respectively. FIG. 69B depicts the embodiment shown in FIG. 69A



with the sharps protruding through the housings. The sensor housing accommodates a sensor. In some embodiments, the sensor is an analyte sensor. Analytes sensed include blood glucose, but in other embodiments, this analyte sensor can be any type of analyte sensor desired.

5

Referring now to FIG. 67B, the base **Y** is shown on the body of a patient **12**. The sensor **5020** is shown having been inserted through the base **Y** sensor housing **5022** and into the patient **12**. Referring now to FIG. 67C, in some embodiments, the cannula **5010** and sensor **5020** are inserted through their respective housing (**5030** and **5022**) and into the patient **12** simultaneously. Referring next to FIG. 67D, the base **Y** is shown attached to the patient with both a cannula **5010** and sensor **5020** attached to the patient **12** through the base **Y**.

10

15

20

Referring now to FIG. 67E, the base **Y** is shown attached to a patient **12** and the cannula **5010** inserted through the cannula housing **5030**. In this embodiment, the sensor housing **5022** is shown without a sensor. However, a sensor **5020** is shown inserted into the patient **12** in another location. Thus, the sensor **5020** is not required to be inserted through the base **Y**, but embodiments described below relating to monitoring blood glucose and pumping insulin through a cannula can be implemented in this way. Additionally, other embodiments relating to administering a fluid in response or relation to an analyte level can be administered this way.

25

Referring now to FIG. 67F, the device **10**, having both a sensor **5020** and a cannula **5010** through the base **Y** is shown with the top **X** placed on. Again, in the embodiments shown in FIGS. 66A-66D, once the top **X** is placed onto the base **Y**, the reservoir **20** is fluidly connected to the fluid line **310**.

30

Referring now to FIG. 68, one embodiment of the portable pump embodiment of the device **10** is shown. In this device **10**, an insertion set, including a cannula **5010** and tubing **5033**, is necessary to connect the fluid line in the device **10** to the patient **12**. Thus, the cannula **5010** is not connected, in this embodiment, through the portable

pump device 10 to the patient 12 directly. Additionally, although this embodiment can function as described below with respect to an analyte sensor and a fluid pump, the sensor 5020 will be located outside the portable pump device 10 similar to the embodiment of the sensor 5020 shown in FIG. 5F.

5

Referring now to FIGS. 70-70D, both the patch pump and portable pump embodiments as described additionally contain various components of the dispensing assembly (in applicable embodiments) and for embodiments including the AVS assembly, the various components thereof, including, at least one microphone, a temperature sensor, at least one speaker, a variable volume dispensing chamber, a variable volume chamber, a port and a reference chamber. In some embodiments, the device contains one or more of the following: a vibrator motor (and, in those embodiments, a motor driver), an antenna, a radio, a skin temperature sensor, a bolus button, and in some embodiments, one or more additional buttons. In some embodiments, the antenna is a quarter-wavelength trace antenna. In other embodiments the antenna may be a half-wavelength or quarter wavelength trace, dipole, monopole, or loop antenna. The radio, in some embodiments, is a 2.4 GHz radio, but in other embodiments, the radio is a 400 MHz radio. In still other embodiments, the radio can be any frequency radio. Thus, in some embodiments, the device includes a radio strong enough to communicate to a receiver within a few feet in distance from the device. In some embodiments, the device includes a second radio. In some embodiments, the second radio may be a specific long-range radio, for example, a 433 or 900 MHz radio or, in some embodiments, any frequency within the ISM band or other bands. Not shown in FIGS. 70-70D, the device, in some embodiments, contains a screen and/or a user interface.

25

The following description of these components and the various embodiments thereof are applicable to both device types, and further, to the various embodiments described with respect to each device type. Referring now to FIG. 67F, for illustration purposes only, both the cannula 5010 and the sensor 5020 have been inserted into the device 10. Also, referring to FIGS. 70-70D, the various components, some of which will not

30

necessarily be included in all embodiments, are shown in a schematic representing the electrical connections of those components. FIGS. 70-70D therefore represent the various elements that could be included in the device. These can be mixed and matched depending on size requirements, power restrictions, usage and preferences, as well as other variables. FIG. 70 shows the relation of FIGS. 70A-70D.

The device contains at least one microprocessor 271. This can be any speed microprocessor capable of processing, at a minimum, the various electrical connections necessary for the device to function. In some embodiments, the device contains more than one microprocessor, as seen in FIGS. 70A-70B, the device is shown having two microprocessors 271.

The microprocessor 271 (or in some embodiments, microprocessors) is connected to the main printed circuit board (hereinafter, the "PCB" refers to the term "printed circuit board") 13. A power source, which in some embodiments is a battery 15, is connected to the main PCB 13. In one embodiment, the battery 15 is a lithium polymer battery capable of being recharged. In other embodiments, the battery can be a replaceable battery or a rechargeable battery of any type.

In some embodiments, the device includes a radio 370 connected to the main PCB 13. The radio 370 communicates to a remote controller 3470 using the antenna 3580. The communication between the device 10 and the remote controller 3470 is therefore wireless.

In some embodiments, the device contains a vibration motor 3210. The vibration motor 3210 is connected to a motor driver 3211 on the main PCB 13 motor driver 3211.

Some embodiments include a bolus button 3213. The bolus button 3213 functions by a user applying force to a button form 3213, which can be made from rubber or any other suitable material. The force actuates the bolus button actuation, which is

attached to a bolus button switch **3214** on the main PCB **13**. The switch **3214** activates a single bolus which will indicate a particular pre-determined volume of fluid is to be delivered to the patient. After the user presses the bolus button **3213**, in some embodiments, the device **10** will generate an alarm (e.g., activate the vibration motor **3210** and/or send a signal to the remote controller) to signal to the user that the button **3213** was pressed. The user will then need to confirm the bolus should be delivered, for example, by depressing the button **3213**. In still other embodiments, the remote controller **3470** queries the user to confirm the bolus should be delivered.

A similar query/response sequence may be used in various embodiments to test and report on patient responsiveness. For example, the device may be configured to test patient responsiveness by generating an alarm (e.g., an audible and/or tactile alarm) and awaiting a response from the patient (e.g., actuation of the button **3213**). Such a test may be performed at various times (e.g., every five minutes) or upon detection of a condition such as an abnormal analyte level monitored via an analyte sensor or an abnormal body temperature monitored via a temperature sensor. If the patient does not provide an appropriate response within a predetermined amount of time, the reusable portion may send an alarm to a remote controller or caretaker. Such testing and reporting might be particularly valuable for patients who could become unconscious or incapacitated, either from a device malfunction or otherwise.

The NITINOL circuit (referring to the shape memory actuator, which in some embodiments, is a NITINOL strand) **278** on the main PCB **13** provides electrical current to the NITINOL connectors. As shown in FIG. 67F and FIG. 70A, the device can include two NITINOL connectors **278** (and two NITINOL strands). However, as described above, in some embodiments, the device includes one NITINOL connector (and one NITINOL strand).

In some embodiments, the device includes a temperature sensor **3216** shown on FIG. 70B. The temperature sensor **3216** is located on the underside of the base **Y** and senses the temperature of the patient's skin. The skin temperature sensor **3216** is

connected to a signal conditioner, represented by **3217**. As shown in FIG. 70B, the signal conditioning **3217** is represented as one block, however the device includes multiple signal conditioners, as needed, each filtering different the signals.

5 Following, the AVS temperature sensor **132**, AVS microphones **133**, and analyte sensor **5020** are all connected to a signal conditioner, represented in one block as **3217**.

The AVS speaker **134** is connected to the speaker drive **135** on the main PCB **13**. The AVS speaker **134**, in one embodiment, is a hearing aid speaker. However, in  
10 other embodiments, the speaker **134** (a speaker containing a voice coil, a magnet with an electromagnetic coil) is a piezo speaker (shown in FIG. 50, representing one embodiment of the device).

Referring still to FIGS. 70-70D, in some embodiments, the antenna **3580** has a  
15 dedicated PCB **3581**, which is then connected to the main PCB **13**. Also, in some embodiments, the AVS microphones **133** each have a dedicated PCB **1332**, **1333**, connected to the main PCB **13**. The various PCBs may be connected to the main PCB **13** using conventional methods, for example, flexible circuits or wires.

20 Referring to FIG. 67F, the device **10** is shown as an exemplary embodiment for description purposes. However, the layout of the various parts can vary and many of the embodiments are shown below. However, additional alternate embodiments are not shown but can be determined based on size, power and use.

25 In accordance with an alternate embodiment, the disposable portion **2610** may include the reservoir **20** and optionally, a battery. The reservoir **20** may be integral to the disposable portion or otherwise coupled to the disposable portion. The battery may be the primary or sole power source for the device or may be a backup power source,  
30 and may be used to provide electrical power to electronics on the reusable portion and/or the disposable portion. Both the reservoir **20** and the battery will typically require regular replacement, so including both of these components in the disposable

portion **2610** may provide to the user the increased convenience of simultaneous replacement. Additionally, by replacing the battery every time the reservoir is changed, the user may be less likely to allow the battery to run down.

5 The disposable portion **2610** could additionally or alternatively include a processor that may be used, for example, to continue certain device operations in the event of a failure (e.g., a failure of a main controller in the reusable portion), to generate an alarm in the event of a failure, or to provide status information to the reusable portion. With regard to status information, the processor could keep track of the operation  
10 history and various characteristics of the disposable and hold status information for access by the user, the fluid delivery device **10**, and/or the user interface **14** including during installation of the disposable portion **2610**. For instance, the processor can store status related to shelf life, maximum exposure or operation temperature, manufacturer, safe dispensing limits for the therapeutic, etc. If any of these status  
15 indicators is determined by the device to be unacceptable, the device can refuse to power the pumping assembly and dispensing assembly and indicate to the user that the disposable is not usable. The processor may be powered by a battery in the reusable portion or the disposable portion.

20 More generally, the device may be configured to obtain status information from any of the disposables (including, for example, the disposable portion **2610** and any disposable component used therewith, such as the fluid reservoir, battery, or sharps cartridge or individual sharps component), for example, from a processor disposed in  
25 disposable portion, via bar code reader, or via RFID technology. If the device detects a problem with the disposables (e.g., invalid model number for use with the reusable portion or an expiration date of the fluid has passed), then the device may take remedial action, such as, for example, preventing or terminating operation of the device and generating an appropriate alarm.

30 Additional components may be included in some embodiments. For example, redundant failure detection and announcement mechanisms can be employed. The

device may employ an audible alarm. The loudspeaker 1202 of the sensor 550 may be used for the audible alarm or an additional speaker may be included loudspeaker and used for the audible alarm. The device vibrating mechanism 3210 can also be used as an alarm. If a system failure is detected that requires immediate attention, both alarms can be activated. Additionally, a secondary battery or supercapacitor may be employed as a backup to the primary battery. If either battery fails, the controller can activate one or more alarms so that at least one announcement of battery failure occurs.

The alarms can also be used to indicate to a user that the device is working properly. For example, a user might program the device for a bolus delivery over a certain period of time. The user may desire to know that the programmed delivery is occurring properly. The processor can use the vibrating motor or an audio sound to indicate successful programmed delivery. Thus, some mechanisms can be employed in some embodiments of the device to provide feedback, whether positive or negative, to the patient or user.

A microphone may also be used to detect any abnormal vibration or lack of normal vibrations and trigger an alarm condition. In various embodiments, a microphone of the acoustic volume sensing system may be used to perform such monitoring, or a separate microphone may be included for such monitoring. Periodic checks can also be performed to determine that the device is operating by checking for expected pump vibrations with the microphone. If improper vibrations are detected, or if proper vibrations are not detected by the microphone, an alarm can be activated.

Referring now to FIG. 71, various components of a device 10 are shown schematically. In one embodiment of the device 10, a top X portion mates with a base portion Y and a reservoir 20 is sandwiched between the top X and base Y. The force of the sandwiching allows the reservoir septum 6272 to mate with the base portion Y. In some embodiments, both an infusion device 5010 and an analyte sensor 5020 are inserted through the base Y and into a patient (not shown).

In many embodiments, the base Y and the reservoir 20 are disposable portions and the top X is a non-disposable portion. Both the infusion device 5010 and the analyte sensor are also disposable.

5

As previously discussed, the patch pump device may be entirely or partially disposable. FIG. 72 shows an embodiment of a fluid delivery device 10 having disposable and non-disposable portions. In this embodiment, the disposable portion Y contains components that come into direct contact with the fluid, including the collapsible reservoir 20, pumping assembly (not shown), the variable volume  
10 dispensing chamber 122 (part of the dispensing assembly 120, located on the top X) and the flow restrictor (not shown), as well as one way valves (not shown) and a fluid path (not shown) connecting the reservoir to the pumping mechanism to the variable volume dispensing chamber 122. Additionally, the disposable portion Y includes a  
15 reservoir cavity 2645

The reusable portion X includes elements of the dispensing assembly 120 except the variable volume dispensing chamber 122, which is located on the disposable portion Y. In some embodiments, the dispensing assembly 120 is an AVS assembly. The AVS assembly is described in detail above. Referring now to FIG. 73, an integrated  
20 acoustic volume measurement sensor is shown on a PCB.

Referring now to FIG. 74, the device 10 shown in FIG. 49 is shown. The base  
25 disposable portion Y includes a reservoir cavity 2645. The top non-disposable portion X includes battery 15 and a dispensing assembly 120. A microphone 133 is shown as well as a diaphragm spring 130. In some embodiments, the dispensing assembly 120 includes more than one microphone. Although throughout this  
30 description, each microphone is referred to as 133, this does not infer that the microphones are always identical. In some embodiments, the microphones are the same, in other embodiments, the microphones are different.



In the FIG. 74, the top non-disposable portion X also includes main PCB 13, a vibration motor 3210 and a pumping actuation member 54. The top, non-disposable portion X includes the AVS assembly or dispensing assembly 120. In FIG. 74, a microphone 133 is shown. The top, non-disposable portion X also includes a battery 15, which may be used to provide electrical power to electronics on the non-disposable portion and/or the disposable portion. In some embodiments, this battery 15 is rechargeable. Recharging can be done by methods described below. The disposable portion Y includes the wetted components including a fluid line (not shown) and the pumping assembly. In FIG. 74, only the pumping plunger 54 can be seen. This embodiment of the device 10 can also include many of the elements described above, including, but not limited to, a fluid impedance, a flexible membrane, a cannula housing and a sensor housing. Any pumping mechanism can be used.

Referring now to FIG. 75, the device 10 is shown in another view where more elements are visible. In FIG. 75, the device 10 is shown with base disposable portion Y including a coiled microtubing flow restrictor 340 and a fluid line 310 connecting the inlet 21 and outlet 22 valves. The pumping actuation member 54 is also shown. The top X includes a main PCB 13, a vibration motor 3210, two microphones 133, a speaker 134, a reference chamber 127 and a fixed volume chamber 129. A battery 15 is also shown. Since choosing a very small diameter for the flow restrictor 340, may cause occlusion of the line 310 (for example, due to protein aggregates in a therapeutic fluid), it may be desirable to use a longer length of tubing with a larger diameter. However, in order to pack a longer length of tubing within a patch-sized housing, it may be necessary to bend the tubing in to form a tortuous path, e.g, a coiled or serpentine shape.

Referring now to FIG. 76, an exploded view of the device 10 shown in FIGS. 72, 74 and 75 is shown. The top, non-disposable portion X is shown separated from the base disposable portion Y. In practice, a reservoir (not shown) would be placed in

between the top X and base Y portions. Once the top X and base Y are assembled to form a device 10, the reservoir will become connected to the fluid line 310.

5 Referring now to FIG. 77, an exploded view of another embodiment of a device 10 including a disposable base Y and non-disposable top X part is shown. Also included is a reservoir 20, an adhesive 3100 and a bridge 5040 apparatus holding an infusion device 5010 and a sensor 5020. This device 10 includes a more rounded footprint and a dome shape. A battery 15 and a main PCB 13 are shown located on the top X. The base Y includes a reservoir cavity 2645. An adhesive 3100 is shown in a two piece  
10 embodiment. The bridge 5040 is used to insert the infusion device 5010 and sensor 5020 through the base Y. The reservoir 20 is shown as having an irregular shape, however, in other embodiments, the reservoir 20 can have any shape and can vary in size according to the fluid capacity desired. In this embodiment of the device 10, the non wetted components are in the top non-disposable X and the wetted components  
15 are in the base disposable Y.

When assembled, the device 10 may be adhered together using a center region of the adhesive (not shown). Alternately, the device 10 may be locked together mechanically using any of many embodiments described herein for latching.  
20 Although some embodiments are described below herein, many others will be apparent and as the shape of the device varies, in many cases, the latch will also.

Referring now to FIG. 78, an exploded view of another embodiment of the device 10 is shown. The top non-disposable portion X is mostly dome shaped, however, a  
25 protrusion X1 is shown to accommodate the mechanisms inside the top X. Thus, the shape of the device can vary and can include polyps and protrusions, dimples and other texture-like features to accommodate various designs of the device.

The reservoir 20, infusion device 5010 and sensor 5020 are shown. The infusion  
30 device 5010 and sensor 5020 can be inserted through the base Y and into a patient (not shown). The base Y is shown with an adhesive 3100 or pad 3220 underneath. In

practice, the adhesive **3100** or pad **3220** can be first adhered to the skin and base Y. Next, the infusion device **5010** and sensor **5020** are inserted through the base Y into a patient (not shown, shown in FIG. 79 as **5020** and **5010**). The reservoir **20** is then placed into the reservoir cavity **2645** either by first placing the reservoir **20** into the top X then sandwiching the top X and the base Y, or, placing the reservoir **20** into the reservoir cavity **2645** and then sandwiching the top X and the base Y. Either way can be used. The final result is the reservoir **20** becomes connected to the fluid line (not shown) located in the base Y through a septum (shown upside down) on the reservoir **20** and a septum needle (not shown, see **6272**). The top X is then fastened to the base X either through use of an adhesive, or in this embodiment, mechanically using a latch **654** to clamp the top X and base Y together.

The base Y includes those components that are wetted. The base Y is disposable. The top X includes non wetted components. The top X is non-disposable. Referring now to FIG. 79, the base Y includes a variable volume dispensing chamber **122**, an inlet valve **21**, and exit valve **22** and a pumping chamber **2350**. As shown in this figure, those elements are shown as the membrane covering the area that acts as either the chambers or the valves. Thus, the base Y includes the membrane that securely maintains the wetted areas, thus, maintaining the non wetted areas as such in the top (not shown). As shown in FIG. 79, the sensor **5020** and the infusion device **5010** have been inserted into their respective housings and through the base Y to the patient (not shown). The base Y is shown with the reservoir cavity **2645**, but the reservoir (not shown) need to be connected so that the fluid lines from the reservoir to the chamber and to the infusion device are connected.

Referring now to FIG. 80, the top X of the device is shown. The top X includes those non wetted components including, as shown, a temperature sensor **3216**, a diaphragm spring **130**, an inlet valve poppet **21**, and exit valve poppet **22** and a pumping actuation member **54**. The top Y also includes a relief **2640** to accommodate the reservoir (not shown).

Referring now to FIGS. 81A-81C, a sequence is shown to illustrate the process of sandwiching the reservoir 20 between the top X and base Y. As seen in FIG. 81A, the top X as well as the reservoir 20 outside of the top X are shown. The reservoir includes a septum 6270. The top X includes a reservoir relief 2640. Next, as shown in FIG. 81B, the top is prepared to sandwich with the base Y. Referring now to FIG. 81C, the reservoir 20 is placed, septum side down, inside the base Y. The septum will connect with a cannulated septum needle (not shown) inside the base Y and connect the reservoir to the fluid line (not shown). In alternate embodiments, the reservoir may include a cannulated needle rather than a septum and the fluid path may include a reservoir interface with a septum rather than a cannulated needle.

Referring next to FIG. 82, the top X is shown with one embodiment of the pumping mechanism 16 exploded. The pumping mechanism 16 fits into the pumping mechanism housing 18 in the top X. The base Y is also shown as well as one part of the latch 654 that will clamp the top X and base Y together.

Referring now to FIG. 83, the base Y is shown with the fluid path assembly 166 as the membrane 2356 exploded from the base Y. This illustrates that in some embodiments of the device, the fluid path assembly 166 is a separate part that is inserted into the base Y and sandwiched with the membrane 2356. Also shown in this figure, the adhesive or pad 3100/3220 in some embodiments, includes apertures for the infusion device and sensor (not shown). Referring now to FIG. 84, a bottom view of the base Y is shown. The bottom of the fluid path assembly 166.

Referring now to FIGS 85A and 85B, another embodiment of the device is shown. In this embodiment, the top X, also non-disposable, includes a bolus button 654. The reservoir 20 is shown in an exploded view, however, in one embodiment, the reservoir 20 is built into the base Y. In another embodiment, the reservoir 20 is removable and placed into the reservoir cavity 2645 using a process similar to that described above with respect to another embodiment of the device.

The base Y is disposable and includes the wetted parts of the device **10**. The sensor **5020**, the cannula **5010**, the variable volume dispensing chamber **122**, the inlet valve area **21**, the exit valve area **22** and the pumping chamber **2350**. The volume dispensing chamber, the inlet valve area **21**, the exit valve area **22** and the pumping chamber **2354** are all covered by membrane material, which may be in the form of a single membrane or distinct membranes.

The device **10** is clamped together by a latch mechanism **654** on the top X and the base Y. Referring now to FIGS. 85C-85D, the device **10** is the latching mechanism **654** is shown in an open position (FIG. 85C) and a clamped or closed position (FIG. 85D). The bolus button **3213**, as described in further detail above, can also be seen.

A cover (not shown) may be provided for use in any of the embodiments of the device, to replace the reservoir and top portion when the reservoir is removed while the base is connected to the patient. The cover would not contain electrical components, thus, could be used in wet conditions. However, in some instances, the reservoir can be removed without the use of any cover.

#### Cannula and Inserter

FIG. 86A schematically shows a representative embodiment of the infusion and sensor assembly **5040** including both an infusion device, which can be a cannula or a needle **5010** and an analyte sensor, which includes a sensor probe **5025** and a sensor base **5023**. A bridge **5070** rigidly joins an infusion cannula **5010** and the analyte sensor base **5023**. The infusion device **5010** is bounded on an upper side by a septum **5060** which allows for fluid to flow from a source and be administered through an infusion device **5010** to a patient. The sensor base **5023** is the section of the analyte sensor that is not inserted into the patient. In one embodiment, the base **5023** contains electronic contacts for the electrochemical analysis of blood glucose. A probe **5025** protrudes from the base **5023** of the analyte sensor **5020**.

Referring now to FIG. 86B, in this embodiment, the infusion device **5010** is a cannula that is introduced into the patient using an introducing needle **5240**. The introduction needle **5240** is inside the cannula **5010** when being inserted into a patient. After insertion of the cannula **5010** into the patient, the introduction needle **5240** is removed and the septum **5060** is sealed to a fluid source, which, in some embodiments of the device described herein, is the fluid line. In some embodiments, the sensor probe **5025** is associated with an introduction needle **5072** which aids in skin puncture for insertion of the sensor probe **5025**. The sensor introduction needle **5072**, in some embodiments, at least partially surrounds the sensor probe **5025** while the sensor probe **5025** is being inserted into a patient.

In other embodiments, the infusion device **5010** is a needle and does not require an introduction needle **5240**. In these embodiments, the infusion device **5010** is inserted into the patient and the septum **5060** seals with a fluid source.

In both FIGS. 86A and 86B, upon both the infusion device **5010** and sensor probe **5025** being lined up appropriately, force is applied to the bridge **5070**. This forces both the infusion device **5010** and sensor probe **5025** into the patient. Once in the patient, releases **5052** are actuated through holes, separating the infusion device **5010** and septum **5060**, as well as the sensor base **5023**, from the bridge **5070**. Referring to FIG. 86B, where introduction needles **5240** and **5072** are used, they will typically remain attached to the bridge **5070** following insertion.

The bridge can be made from any material desired, including plastic. The cannula can be any cannula in the art. The septum **5060** can be made from rubber or plastic and have any design capable of imparting the functions desired. In the embodiments where the infusion device is a needle, any needle may be used. In embodiments where introduction needles are used, any needle, needle device or introduction device can be used.

The infusion and sensor assembly requires force be applied in order to be inserted into a patient. As well, the infusion and sensor assembly requires that the infusion device and sensor are released from the infusion and sensor assembly. Thus, both the force and the release can be actuated manually, i.e., a person performs these functions, or an insertion device may be used to actuate the assembly properly. Referring now to FIGS. 87A-87E, an example of an inserter **5011** that can be manually operated is shown. The infusion device **5010** and sensor **5023** are held by the bridge **5070**. The inserter **5011** includes covers **5012** for both the infusion device **5010** and the sensor **5023**. As shown in FIGS. 87B – 87E, using the inserter **5011**, both the infusion device **5010** and the sensor **5023** are inserted through a device **10**. Although FIG. 87A shows the sharps exposed, in some embodiments, the covers **5012** completely encase the sharps prior to the insertion process.

The inserter **5011** could be operated manually, but could also be incorporated into another inserter device such that a mechanical advantage can be applied. Referring now to FIGS. 88A-88B, one embodiment of an inserter device **5013** is used with an apparatus similar to the inserter **5012** shown in FIGS. 87A-87E. The mechanism of the inserter device **5013** is shown in FIGS. 88C-88D. An actuation lever **5014** either releases a spring (as shown in FIGS. 88C-88D) or provides another mechanical advantage that allows for the inserter **5012** to be inserted through a device (not shown). The inserter **5012** will thus release the infusion device **5010** and sensor **5023** and then, the inserter **5012** can either be removed from the inserter device **5013** and the inserter device **5013** refilled, or, the inserter device **5013** and inserter **5012** can be discarded.

Various insertion devices are described herein. However, in other embodiments, different insertion devices are used or the infusion device and sensor are introduced manually.

Features may be included for securing the infusion and sensor assembly **5040** to an automatic inserter. For example, the releases shown in FIGS. 86A-86B as **5052** may

receive pins of an automatic insertion device. Referring to both FIGS. 89A and 89B a representative embodiment of an automatic inserter **5100** is shown. As shown in the front view of FIG. 89A, the inserter **5100** includes pins **5130** which travel in pin slots **5140** within an inserting cartridge recess **5120**. In practice, the infusion and sensor assembly (not shown, shown in FIGS. 86A and 86B as **5040**) is pressed into the cartridge recess **5120**, causing pins **5130** to be inserted into the holes in the infusion and sensor assembly (shown as **5052** in FIGS. 86A and 86B). As shown in the rear view of FIG. 89B, a cocking lever **5145** is used to ready the inserter **5100** for firing. The inserter **5100** is then either held against the skin or aligned with a cannula housing and sensor housing on a base (not shown) and fired by pressing a trigger **5110**. Upon firing, the pins **5130** travel in their slots **5140**, thereby forcing the infusion device and sensor (both not shown) into a patient. Inserter foot **5160** limits the downward travel of the infusion and sensor assembly. The inserter may also automatically withdraw the introduction needles (not shown, see FIGS. 86B) from the infusion and sensor assembly.

The infusion and sensor assembly may be preloaded in the inserter **5100** prior to distribution to an end user. As shown in FIG. 90, in other embodiments, a cartridge **5080** may be used to protect a user and to protect the sharps held in the assembly shown as **5040** in FIGS. 56A and 56B. Referring to both FIGS. 90 and FIGS. 86A-86B and FIG. 89A, in the cartridge embodiment **5080**, the infusion and sensor assembly **5040** is embedded in the cartridge **5080**. The cartridge **5080** is mounted in the cartridge recess **5120**. The pins **5130** may project through the holes **5052** and into grooves **5090** in the cartridge **5080**. Upon actuation of the inserter **5100**, the pins travel within the grooves **5090** as the **5080** travels toward the patient to insert the sharps. The cartridge **5080** may be constructed of a rigid material.

Referring now to FIGS. 91A-91C, several views of an embodiment of an inserter mechanism for an inserter, such as the one shown in FIGS. 89A and 89B as **5100**, are shown. FIG. 91A shows a perspective view, FIG. 91B shows a front view, and FIG. 91C shows a side view of one embodiment of an inserter mechanism. The inserter



**5100** has a cocking lever **5145**, which connects via cocking linkages **5350** to a hammer cocking slide **5330**, and is used to move the cocking slide **5330** to a charged position. A power spring **5390** connects the hammer cocking slide **5330** to a trigger **5110** and, when compressed, provides the downward force necessary for insertion of an infusion device or an infusion and sensor assembly (not shown). A trigger hammer **5340** is disposed under the hammer cocking slide **5330** and between a pair of cocking linkages **5350**; the trigger hammer **5340** transmits the kinetic energy that is released from the power spring **5390** upon pressing the trigger **5110**. The energized trigger hammer **5340** impacts a cartridge bolt **5380**, positioned below. The cartridge bolt **5380** is linked to a cartridge housing **5370**, which holds the cartridge, for example, the one shown in FIG. 90. The cartridge bolt **5380** is also disposed atop a return spring **5360** for returning the cartridge housing **5350** to a retracted position.

FIGS. 92A-92F schematically show a time sequence for the cocking and firing of an inserter **5100** of the type described with reference to FIGS. 91A-91C. FIG. 92A shows the inserter **5100** in a resting position. Lowering the cocking lever (not shown, see FIG. 91A **5145**) causes the hammer cocking slide **5330** to lower and engage the trigger hammer **5340**. FIG. 92B shows the hammer cocking slide **5330** in a lowered position in which it is engaged with the trigger hammer **5340**. Raising the cocking lever causes the hammer cocking slide **5330** and hammer **5340** to be raised, thus compressing the power spring **5390**; the resulting position is shown in FIG. 92C. After ensuring the proper positioning of the inserter **5100** with respect to a base (not shown) and/or the skin of a patient, the trigger is pressed, thereby sending the trigger hammer **5340** downward; FIG. 92D shows the trigger hammer **5340** in transit. As shown in FIG. 92E, the trigger hammer **5340** impacts the cartridge bolt **5380**, causing it to travel downward, insert the needle or needles held in the cartridge housing (not shown) and compress the return spring **5360**. FIG. 92F shows the return spring **5360** in the process of forcing the cartridge bolt **5380** upward; this causes retraction of the cartridge housing and the cartridge contained therein (not shown) and any associated introduction needles used.

Referring now to FIGS. 93A-93C, one embodiment of a temporal sequence for inserting and securing an infusion device (i.e., cannula or needle 5010) into a base Y is shown. FIG. 93A shows a base Y with a locking feature 5210 positioned above a cannula housing 5030. The base Y is typically positioned against the skin of a patient 5220 when inserting an infusion device or cannula 5010. FIG. 93B shows a cannula 5010 being forced through the cannula housing 5030 in the base Y. In this figure, an introduction needle 5240 is used that traverses a septum (not shown) and is positioned coaxially in the cannula 5010; a sharp point of the introduction needle 5240 emerges from the tip (not shown) of the cannula 5010 to help puncture a patient 5220. The resilient locking feature 5210 is pushed aside during insertion of the cannula 5010. FIG. 93C shows the cannula 5010 fully inserted through the cannula housing 5030 of the base Y, with the tip of the cannula fully inserted into the patient 5220. The introduction needle 5240 has been removed and the septum 5060 has self-sealed to a fluid source or fluid line (not shown). The resilient locking feature 5210 is engaged with the cannula 5010, thereby preventing the cannula 5010 from moving in relation to the base Y. Although FIGS. 93A-93C show a cannula 5010, the infusion and sensor assembly shown in FIGS. 86B can be inserted using the locking feature 5210 and method shown and described in FIGS. 93A-93C.

Referring now to FIGS. 92G-92H, an inserting cartridge bolt locking mechanism for use with an inserter, such as the one shown in FIGS. 91A-92F, as 5100 is shown. The cartridge bolt locking mechanism can function as an interlock to prevent accidental firing while the mechanism is being cocked. The locking mechanism includes a catch 5420, which when engaged in a catch recess 5410, prevents downward movement of the cartridge bolt 5380. As shown in FIG. 92G, when the cocking lever 5145 is in a closed position, the cocking lever 5145 contacts a catch lever 5440, which rotates the catch 5420 and prevents the catch 5420 from inserting into the catch recess 5410. A catch spring 5430, disposed between the catch 5420 and a catch spring support 5450, is in a compressed positioned. The cartridge bolt 5380 and trigger hammer 5340 are free to move. As shown in FIG. 92H, when the cocking lever 5145 is rotated into a downward position, the catch lever 5440 is released, thereby allowing the catch

spring **5430** to force the catch **5420** to insert into the recess (here the catch **5420** is shown inside the recess, but the recess is shown in FIG. 92G as **5410**); downward movement of the cartridge bolt **5380** is thereby prevented. Return of the cocking lever **5145** then returns the catch **5420** to an unlocked position. The cartridge bolt **5380** is then free for downward movement in the triggering process.

Referring now to FIGS. 94A-94C, one embodiment of the process of mating a cannula **5010**, where the cannula is a traditional cannula requiring an introduction needle (as shown in FIG. 86B) to the base Y and establishes fluid communication with a fluid line **310** is shown. FIG. 94A shows a sectional view of a cannula **5010** with two septa: an introduction needle septum **5062** and a fluid line septum **5270**. The introduction needle septum **5062** seals a passageway **5280** leading to the hollow needle (not shown, shown in FIG. 94B as **5290**) of the cannula **5010**. A cannula introduction needle **5240** is shown positioned above the introduction needle septum **5062** and just prior to insertion of the introduction needle **5240**.

Referring now to FIG. 94B, the introduction needle **5240** is shown inserted through the introduction needle septum **5062**. A user mates the cannula **5010** into the base Y, which has an upwardly-pointing rigid, hollow needle **5290**. During insertion of the cannula **5010** into the base Y, the introduction needle **5240** punctures the fluid line septum **5270** to establish fluid communication between the fluid line **310** and the passageway **5280**. If the base Y is held against a patient (not shown) during insertion of the cannula **5010** into the base Y, fluid communication between the fluid line **310** and the passageway **5280** will be established at about the same time that the patient's skin is pierced. Referring now to FIG. 94C, the cannula **5010** is shown, fully inserted into the base Y, with the introduction needle removed and fluid communication established with the fluid line **310**.

In an alternate embodiment, insertion of an infusion device and/or sensor is assisted by a vibration motor coordinated with a fluid delivery device. Simultaneously with the insertion of the infusion device and /or sensor, a vibration motor may be activated.

### Adhesion

Referring now to FIG. 95 a top perspective view of one embodiment of an adhesive patch 3100 for securing an object, such as a fluid delivery device 10, to the skin of a patient (not shown) is shown. Although the adhesive patch 3100 is shown in the present shape, other shapes can be used. Any adhesive patch 3100 that can securely hold a fluid delivery device can be used.

Fluid delivery device 10 is securely held under a central region 3130 of the adhesive patch 3100, which is attached to the skin of a patient by adhesive members 3111. These adhesive members 3111 emanate from a central region 3130 in a radial pattern and are spaced apart from each other by intervening regions 3121. The radial arrangement of the adhesive members 3111 allows for attachment of the device 10 to the patient in secure manner. In some embodiments, the central region 3130 covers the entire device 10, however, in other embodiments, the central region 3130 covers a portion of the device 10. The central region 3130 may also include interlocking attachment features (not shown) that may be held by complementary interlocking features (not shown) of the device 10. In an alternate embodiment, the device 10 is securely attached atop the central region 3130 (for example, by an adhesive or interlocking feature).

The adhesive patch 3100 is typically flat and composed of a polymeric sheet or fabric. The adhesive patch 3100 may be supplied with adhesive affixed on one side and protected by a peelable backing such as a peelable sheet of plastic to which the adhesive will adhere more loosely than to the patch 3100. The backing may be a single continuous piece, or may be divided into regions that may be removed separately.

In an illustrative embodiment, the backing for the central region 3130 may be removable without removing the backing to the adhesive members 3111. To use the adhesive patch 3100, a user removes the backing of the central region 3130 and

presses the device **10** against the newly exposed adhesive of the central region to attach the device **10** to the central region **3130**. The user then places the device against the skin, removes the backing from an adhesive member **3111**, affixes the adhesive member to the skin, and repeats the affixation process with additional  
5 members. A user may affix all of the adhesive members **3111** or only some of the members, and save additional adhesive members **3111** for application on another day. Since adhesives typically used for attachment to skin only remain securely attached for several days, application of sets of adhesive members **3111** on different days (for  
10 example, staggered by 3 to 5 days) should extend the amount of time that the device **10** remains securely attached to the skin and reduce the of time, expense and discomfort that is often involved in reapplication of the device. The varying tabs may have indicia such as different colors or numbers to indicate to the appropriate time to affix the various adhesive members **3111**. The adhesive members **3111** may include perforations to render them frangible with respect to the central region **3130**  
15 so that used adhesive members may be removed after use. Additional embodiments for extending the duration during which device **10** remains affixed are discussed above with reference to FIGS. 79-83.

FIG. 96 schematically shows a sectional view of a fluid delivery device **10**, with an  
20 inserted cannula **5010**, held securely under an adhesive patch **3100**. A pad **3220** may be included between the device **10** and a patient's skin **3250** and allow air to flow to the skin. Air flow to skin may be increased by the inclusion of passageways **3230** in the pad **3220**. Passageways **3230** may also be formed by using multiple pads that are spaced apart or by constructing pad **3220** from a highly porous material. Thus, the  
25 pad **3220** can be any shape and size and in some embodiments, the pad **3220** is made up of a number of separate pieces. Pads **3220** may be either adhered to the underside of the device **10** during manufacture or may be adhered to the device **10** by a user. Alternately, the pad **3220** may be loosely placed onto the skin by a user prior to application of the adhesive patch **3100**. The pad **3220** may include a compliant  
30 material, such as porous polymeric foam.

FIG. 97 shows an embodiment of the invention that uses a first adhesive patch **3100** and an additional adhesive patch **3300** to secure a device (not shown) to a patient. First, a device (not shown) is positioned for use and secured to the skin (not shown) of a patient with an adhesive patch **3100** using tab-like adhesive members **3111**. The central region **3130** may be positioned atop (as shown), or secured below, the device. After a period of time, either prolonged or short, a second adhesive patch **3300** is positioned so that its central region sits atop the first adhesive patch **3100** and the second adhesive patch's adhesive members **3320** are secured to the skin of the patient in the intervening regions between the first adhesive patch's adhesive members **3111**. Frangible regions may be provided to aid in the removal of loose or unwanted adhesive members **3111** associated with the earlier placed patch **3100**.

Referring now to both FIGS. 98 and 99, embodiments in which an adhesive patch **3100** has been divided into at least two smaller adhesive patches are shown. In these embodiments, the adhesive patch **3100** is divided into two adhesive patches, **3410** and **3420**, each having adhesive members **3111** radially arranged around a central void **3430**. The two adhesive patches, **3410** and **3420**, each span a semi-circle of about  $180^\circ$ , but other configurations could be used such as: three patches, each spanning  $120^\circ$  or four patches each spanning  $90^\circ$ . In some embodiments, the adhesive can include greater than four patches. The configurations described with respect to these embodiments follow the formula  $360^\circ/n$  where  $n$  is the number of patches. But, in other embodiments, depending on the shape of the device, the formula shown and described here does not apply. In still other embodiments, the patches may also cover more than  $360^\circ$ , and thus overlap.

As shown in the perspective view of FIG. 99, due to the presence of a central void (not shown, shown in FIG. 98), the central region **3130** is in the form of a thin strip for adherently positioning along the perimeter of the device **10**. The two patches, **3410** and **3420**, together securely attach the device **10** to the skin (not shown). As in the embodiment described with reference to FIG. 95, air may flow between the

adhesive members **3111** and under the device **10**, especially if passageways **3230** are provided.

5 FIG. 100 shows a perspective view of an embodiment that includes using the multiple adhesive patches to extend the time during which a device **10** remains adhered to a patient (not shown) before removal. One of the multiple partial adhesive pads **3420** is removed while the device **10** is held in place (either by a remaining adhesive patch **3410** and/or by a user). The removed adhesive patch **3420** is then replaced with a fresh replacement adhesive patch (not shown). The replacement adhesive patch may  
10 be identical to the removed pad **3420** or may have adhesive members **3111** that are positioned in an alternate configuration to allow adhesion to the fresh skin between the areas previously covered by adhesive patch **3420**. The remaining adhesive patch **3410** may then be replaced in a similar manner. Indicia such as color coding may be used to indicate the age of the adhesive patches. The patches may also have a color  
15 change mechanism to indicate that their useful life has expired. Decorative patterns, such as images and designs, may be included on the patches.

FIG. 101 schematically shows an embodiment in which multiple adhesive members **3111** are affixed to a patient **12** and also connected to a ring like central region **3130**  
20 via tethers **3730**. The tethers **3730** may be fibers or cords and may be resilient to decrease the movement of the device **10** in response to movement of the patient **12**. The use of tethers **3730** also increases options available for skin positions of the adhesive members **3111**.

25 The adhesive used in the embodiments described in FIGS. 95-101 can be any effective and safe adhesive available for use on a patient's skin. However, in one embodiment, the adhesive used is 3M product number 9915, value spunlace medical non woven tape.

### 30 Clamping and Latching

FIGS. 102A-102C schematically show one mechanism for clamping or latching

together a top portion and a base portion of a fluid delivery device. Referring first to FIG. 102A, an elevation view of a clamp 6410 is shown. FIG. 102B shows a base portion Y with keyholes 6440 for two clamps; corresponding keyholes may also be included in the top portion (not shown). Referring now to FIG. 102C, the top X and the base Y may be aligned and a clamp 6410 may be inserted through the keyholes (not shown, shown in FIG. 102B as 6440). Rotating the clamp 6410 by 90° causes a stud bar 6430 to move into a locking position. Depressing a cam lever 6400 engages a cam 6415, that is hingedly connected to a clamp pin 6420, to push against the top X. As a result, the top X and the base Y are held with a clamping force between the cam 6415 and the stud bar 6430. Raising the cam lever 6400 releases the clamping force and the clamp 6410 may be rotated by 90° and withdrawn to allow disassembly of the top X and base Y. In some embodiments, the lever may act as a protective cover for the top X.

An alternate embodiment for clamping together the portions of a device is shown in FIGS. 103A-103D. FIG. 103A shows a perspective view and FIG. 103B shows a top view of a cam guide 6500. The cam guide 6500 has a keyhole 6440 and sloped surfaces 6510. FIG. 103C shows a cam follower 6520 having a central pin 6540 with a head 6560 attached at a first end and a bar 6550 attached to an opposite end. As shown in the sectional view of FIG. 103D, the cam follower (not shown, shown in FIG. 103C) may be inserted into keyholes (not shown, shown in FIG. 103C) in the top X, base Y, and cam guide 6500. Movement of a lever 6530 attached to the central pin 6540 causes rotation of the cam follower (not shown, shown in FIG. 103C), causing the bar 6550 to travel along the sloped surface (not shown, shown in FIG. 103C as 6510) and thereby transforming the rotational force to a force which clamps the base Y and top X firmly between the cam follower head 6560 and the bar 6550.

#### Reservoir

Exemplary embodiments of collapsible reservoirs for holding fluids are shown in FIGS. 104-106C. The collapsible reservoir has at least one section or wall that collapses as fluid is withdrawn, thereby maintaining ambient pressure in its interior.



In most embodiments, a sealable port (e.g., a septum) is included in the reservoir. The port allows the reservoir to be filled with fluid by a syringe and also, for a leak free connection to a fluid line. Alternately, an adaptor may be used to connect the reservoir with the fluid line. Alternately, as shown above with reference to FIG. 71, a  
5 needle may be associated with the reservoir and a septum may be associated with the terminus of the fluid line. The reservoir may be constructed of a plastic material known to be compatible, even if for a very short duration, with the fluid contained in the reservoir. In some embodiments, the reservoir is entirely collapsible, i.e., the reservoir does not include any rigid body surfaces.

10

Referring now to FIG. 104 a sectional view of a reservoir **20** is shown. A cavity **2645** for holding a volume of fluid is formed between a rigid reservoir body **6200** and a flexible reservoir membrane **6330**. The flexible membrane **6330** is sealingly attached around the periphery of the cavity **2645** to hold fluid within the cavity **2645**.  
15 The flexible membrane **6330** imparts collapsibility to the reservoir **20**; it deforms inwardly as fluid is pumped from the cavity **2645**.

15

A septum **6270** is seated in a neck **6240** extending from the body **6200**. The septum **6270** serves as an interface between the cavity **2645** and a fluid line. In some devices,  
20 the fluid line terminates in a needle (not shown). In these embodiments, the needle may be inserted through the septum **6270** to access a needle chamber **6280** portion of the cavity **2645**. The septum **6270** location can be maintained by its location between a cap **6250** and a ledge (not shown) formed at the junction of the inner wall **6281** of the needle chamber **6280** and the cap bore **6282**. The cap **6250** may be held by a  
25 friction fit within the cap bore **6282**. Upon insertion of the cap **6250**, its position is limited by the wall **6261** of the cap bore **6282**. The portion of the cap **6250** closest to the septum **6270** may have a central aperture to allow insertion of the needle through the cap **6250** and into the septum **6270**. Alternately, the cap **6250** may be punctured by the needle.

25

30

FIG. 105 shows a perspective view of the inside of the collapsible reservoir 20. A rim 6230 allows attachment of the flexible reservoir membrane, which may be attached by welding, clamping, adhering, or other suitable method to create a fluid tight seal. A guard structure 6290 may be included to allow fluid to flow to or from the cavity 2645, but prevents a needle from entering the cavity, thereby preventing it from possible puncture of the reservoir membrane.

FIGS. 106A-106C show an alternate embodiment of a reservoir in which a cap 6250 sealingly attaches a septum 6270 to a wall 6320 of a reservoir. The wall 6320 could be constructed, for example, from a flexible sheet such as PVC, silicone, polyethylene or from an ACLAR film. In some embodiments, the wall 6320 may be constructed from a heat formable polyethylene laminate formed with an ACLAR firm. The flexible sheet is compatible with the fluid. The wall may be attached to a rigid housing, or part of a flexible plastic pouch, such as may be formed by folding and welding the ends of a plastic sheet. FIG. 106A shows the cap 6250 sealed to a wall 6320 via a circular fin 6350. The septum 6270 may be inserted into a turret 6340 that protrudes from the cap 6250. The turret 6340 may be constructed from a material that is deformable at high temperature, but rigid at room temperature, for example, low density polyethylene. Referring now to FIG. 106B, a hot press 6310, or another apparatus or process for melting, is used to melt or bend the turret 6340 over the septum 6270. Referring now to FIG. 106C, the septum 6270 is shown immobilized to the cap 6250.

Certain fluids are sensitive to storage conditions. For example, insulin may be somewhat stable in the glass vials in which it is typically shipped, but may be unstable when left in prolonged contact with certain plastics. In some embodiments, the reservoir 20 is constructed of such a plastic. In this case, the reservoir 20 may be filled with fluid just prior to use so that the fluid and plastic are in contact for a shorter period time.

#### Reservoir Filling Station

Referring now to FIG. 107 a reservoir filling station **7000** for filling a reservoir **20** with a fluid is shown. The fluid may be withdrawn from its original container with a syringe **7040** and introduced into the reservoir **20** by using the fill station **7000**. The fill station **7000** may include a substantially rigid fill station base **7010** hinged to a substantially rigid fill station cover **7020** via a hinge **7030**. Accordingly, the station **7000** may be opened and closed to accept and hold the reservoir **20**. A needle **7050** attached to the syringe **7040** may then be inserted through a filling aperture **7060** in the cover **7020**, and through the reservoir septum **6270**. Since the fill station cover **7020** is rigid, it establishes a limit of travel upon the syringe **7040** and therefore controls the depth of needle **7050** penetration into the reservoir **20** to discourage puncture of the underside of the reservoir **20**. A leg **7070** holds the station **7000** in a tilted position when supported on a surface. Since the station **7000** is tilted, as the fluid is injected from the syringe **7040** into the reservoir **20**, air will tend to rise upwardly toward the septum **6270**. After the syringe **7040** injects the desired amount of fluid into the reservoir **20**, the syringe **7040** may be used to remove any remaining air in the reservoir **20**. Since the fill station base **7010** and cover **7020** are rigid, the flexible reservoir **20** generally cannot be distended past a fixed volume and overfilling of the reservoir **20** is discouraged. The base **7010** and cover **7020** may be locked together with a clasp, or a heavy cover may be used to further discourage overexpansion and overfilling of the reservoir.

Referring now to FIGS. 108A and 108B, an alternate embodiment of the reservoir filling station **7000** is shown. In this embodiment, the reservoir (not shown) is placed in the space between the cover **7020** and the base **7010**. A hinge **7030** attached the cover **7020** and the base **7010**. As shown in FIG. 108B, the reservoir (not shown) is inside, and a syringe (not shown) needle (not shown) is inserted into the filling aperture **7060**. The filling aperture **7060** connects directly to the reservoir's septum (not shown). A viewing window **7021** indicates the fluid line in terms of the volume of fluid that has been injected into the reservoir.

A fluid delivery system typically includes a fluid delivery device and an external user interface, although in some embodiments a complete or partial internal user interface is included in the device. The device can be any device as described herein or a variation thereof.

5

FIG. 109A shows a flow diagram of a data acquisition and control scheme for an exemplary embodiment of a fluid delivery system. A patient or caregiver utilizes an external user interface **14** which is typically a base station or hand held unit housed separately from the fluid delivery device **10**. In some embodiments, the user interface **14** is integrated with a computer, cell phone, personal digital assistance, or other consumer device. The user interface assembly may be in continuous or intermittent data communication with the fluid delivery device **10** via wireless radio frequency transmission (for example, via LF, RF, or standard wireless protocols such as “Bluetooth”) but could also be connected via data cable, optical connection or other suitable data connection. The external user interface **14** communicates with a processor **1504** to input control parameters such as body mass, fluid dose ranges or other data and receives status and function updates such as the presence of any error conditions resulting from occluded flow, leaks, empty reservoir, poor battery condition, need for maintenance, passage of an expiration date, total amount of fluid delivered or remaining or unauthorized disposable component. The interface **14** may transmit error signals to a patient’s guardian or medical professional through a telephone, email, pager, instant messaging, or other suitable communication medium. A reservoir actuator assembly **1519** includes an actuator **1518** and a reservoir **1520**. The dispensing assembly **120** transmits data related to flow through the flow line to the processor **1504**. The processor **1504** uses the flow data to adjust the action of the actuator **1518** in order to increase or decrease flow from the reservoir pump assembly **1519** to approximate the desired dosage and timing. Optionally, a feedback controller **1506** of the processor **1504** may receive data related to the operation of the reservoir pump assembly **1519** for detection of conditions such as open or short circuit faults, or actuator temperature.

10

15

20

25

30

FIG. 109B shows an alternate embodiment of the flow diagram in FIG. 102A. In this embodiment, the lack of dispensing assembly/sensor removes the feedback based on volume of fluid.

5 Referring now to FIG. 110A, a flow chart of one embodiment of the overall operation of a fluid delivery device within the fluid delivery system is shown. A user starts **2800** the system using a switch or from an external user interface (step **2800**). The system initializes by loading default values, running system tests (step **2810**) and obtaining variable parameters such as desired basal and bolus doses. Variable  
10 parameters may be selected by the user using the user interface, either using an input device such as a touch screen on the user interface or by loading saved parameters from memory (step **2820**). The actuator timing is calculated based on the predicted or calibrated performance of the fluid delivery device (step **2830**). The dispensing assembly is initiated at the start of the fluid delivery device activation (step **2840**).  
15 Dispensing assembly data collection **2835** continues through actuation and delivery. During operation, the dispensing assembly provides data that allows determination of the cumulative volume of fluid that has flowed through the dispensing chamber as well as the flow rate for one or more time periods. The fluid delivery device is activated to cause fluid to flow through the flow line into the dispensing chamber  
20 (step **2840**). Drug flows from the dispensing chamber to the patient at a rate determined by the impedance of the exit, and in some embodiments, the force exerted by a diaphragm spring, and the force exerted by the pumping assembly (step **2860**). The system will stop and the user will be notified if there is a user stop interrupt, a low flow condition, the reservoir is determined to be empty based on predicted  
25 cumulative flow or detection by an additional reservoir volume sensor, or any other alarm operation either part of the system or user specified (step **2870**). If there is no user stop signal, determination of an empty reservoir or another alarm indicator, then a check is made to determine if an adjustment to the actuator timing is needed due to a deviation between the actual and desired flow rate or due to a change in desired  
30 flow rate by the user (step **2880**). If no adjustment is needed, the process returns to step **2840**. If an adjustment is needed, the process instead returns to step **2830**.

Referring now to FIG. 110B, a flow chart of another embodiment of the overall operation of a fluid delivery device within the fluid delivery system is shown. In this embodiment, the decision to adjust the actuation timing is made based on a user inputted variation or on another feedback. In this embodiment, a dispensing assembly with a sensor for determining volume is not included; thus the adjustments are made based on alternative feedback mechanisms.

#### Wireless Communication

Referring now to FIG. 111 a layout of an embodiment using coils for inductive charging and wireless communication in a fluid delivery system is shown. As previously described, the user interface assembly 14 can be embodied as a hand held user interface assembly 14 that wirelessly communicates with the fluid delivery device 10. A secondary coil (i.e. a solenoid) 3560 may be employed in the fluid delivery device 10 as a wireless transceiver antenna in conjunction with wireless controller 3580. The secondary coil 3560 may also serve as a secondary transformer for recharging the device battery 3150, at least partially, in conjunction with a battery recharging circuit 3540. In this embodiment, the user interface assembly 14 contains a primary coil 3490 for inductively coupling energy to a secondary coil 3560. When the user interface assembly 14 is in close proximity to the fluid delivery device 10, the primary coil 3490 energizes the secondary coil 3560. The energized secondary coil 3560 powers a battery recharging circuit 3540 for recharging the battery 3150 in the fluid delivery device 10. In some embodiments, the primary coil 3490 also functions as an antenna to transmit and receive information from the fluid delivery device 10 in conjunction with a wireless controller 3470.

Referring now to FIG. 112, some embodiments include long range wireless communication (e.g., 20-200 ft or more) hardware in the fluid delivery device 10. Thus, the fluid delivery device 10 could be monitored from a distance.

Still referring to FIG. 112, an intermediate transceiver 6600, typically carried by the patient, can provide the benefits of long range communication without increasing the

size, weight and power consumption of the fluid delivery device 10. As shown in the data flow diagram of FIG. 112, a wearable fluid delivery device 10 uses short range hardware and associated software to transmit data to, or receive data from, the intermediate transceiver 6600. For example, the device 10 may be equipped to  
5 transmit data over distances of approximately 3-10 ft. The intermediate transceiver 6600 may then receive this data and use long range hardware and software to relay this data to a user interface assembly 14. The intermediate transceiver 6600 may also accept control signals from the user interface assembly 14 and relay these signals to the device 10. Optionally, the user interface assembly 14 may also be capable of  
10 communicating directly with the fluid delivery device 10, when in range. This direct communication may be configured to occur only when the intermediate transceiver 6600 is not detected, or alternatively, anytime the user interface assembly 14 and the fluid delivery device are within range of each other.

15 Many types of data may be transmitted in this way, which include, but are not limited to:

Data related to the timing of pump actuation and volume measurements and other data from the dispensing assembly may be transmitted to the intermediate transceiver 6600 and, in turn, to the user interface assembly 14;

20 Alarm signals may be transmitted to and from the fluid delivery device 10;

Signals to confirm the receipt of data may be transmitted from the user interface 14 to the intermediate transceiver 6600 and from the intermediate transceiver 6600 to the fluid delivery device 10;

25 Control signals to change the operating parameters of the device 10 may be transmitted from the user interface assembly 14 to the fluid delivery device 10 using the intermediate transceiver 6600.

Referring now to FIG. 113, a plan diagram of a specific embodiment of an intermediate transceiver 6600 is shown. A short range transceiver 6610  
30 communicates with a nearby fluid delivery device. The short range transceivers of the device and the intermediate transceiver 6600 may communicate using one or more

of many protocols and transmission frequencies known to be useful for short range communication, e.g. radio frequency transmission. Data received by the intermediate transceiver **6600** is conveyed to a microprocessor **6630**, which may store the data in memory **6620** (e.g., a flash memory chip), and retrieve the data as needed.

5 The microprocessor **6630** is also connected to a long range transceiver **6640**, which is in data communication with the user interface. For example, the intermediate transceiver **6600** and user interface assembly may operate on the Bluetooth standard which is a spread-spectrum protocol that uses a radio frequency of about 2.45 MHz and may operate over a distance of up to about 30 feet. The Zigbee standard is an

10 alternative standard that operates in the ISM bands around 2.4 GHz, 915 MHz, and 868 MHz. However, any wireless communication could be used.

Optionally, the microprocessor **6630** analyzes received data to detect the presence of malfunctions or maintenance needs associated with the device. Some examples of

15 fault conditions include, but are not limited to:

- a lack of received data for a time period that exceeds a set limit;
- a lack of data receipt confirmation signal from the device or the user interface assembly;
- an overflow or near overflow condition of the appliance memory **6620**;
- 20 low power;
- overly high, low or improperly timed volume measurements received from the fluid delivery device **10**.

Based on this fault analysis, the microprocessor **6630** may trigger an alarm **6650** (e.g.,

25 a bell or buzzer). The microprocessor **6630** may also communicate an alarm condition to a remote device. The remote device may be, for example, the user interface assembly using the long range transceiver **6640**, the fluid delivery device **10** using the short range transceiver, or both the user interface assembly and fluid delivery device. Upon receiving an alarm signal, the user interface assembly may then relay the alarm

30 signal over longer distances to a medical professional or patient guardian (e.g., by pager or telephone call or other methods of communication).



The power supply 6670 may be rechargeable, and may store sufficient energy to operate continuously for a period of time, for example, at least 10 hours. However, the operation time will vary based on use and device. The size of the fluid delivery device may be reduced so that it may easily be carried in a pocket, purse, briefcase, backpack or the like. One embodiment of the device includes a means to withstand routine shocks or spills. Additional features may be included in some embodiments, including, but not limited to, decorative features, or any of a wide range of consumer electronics capabilities such as the ability to play video games, send and receive instant messages, watch digital video, play music, etc. Third party controls may be included to remove or limit the use of such functions during some or all hours of the day. Alternately, the device may be as small and simple as possible, and only serve to repeat short range signals over a longer range. For example, the memory and analysis capability may be omitted.

Referring now to FIG. 114, a data flow diagram for an embodiment of the system is shown. An intermediate transceiver 6600 is shown operating as a universal patient interface that engages in short range communication with multiple devices and relays information from those devices over a long range to one or more user interfaces associated with those devices. Examples of devices include wearable, implantable or internal medical devices including a fluid delivery system, a glucose sensor, a knee joint with an integrated strain sensor, an instrumented enteric probe in pill form, a defibrillator, a pacemaker, and other wearable therapeutic delivery devices. Since different types of devices and devices from different manufacturers may utilize differing short range communication standards and frequencies, the intermediate transceiver 6600 may include hardware (e.g., multiple antennas and circuitry), and software to support multiple protocols.

#### Battery Recharger

Referring now to FIGS. 115 and 116. One embodiment of an apparatus is shown for recharging the battery 7100. In FIG. 15, the top, non-disposable portion of a fluid

delivery device 2620 is shown disconnected from the base, disposable portion of a fluid delivery device. The battery recharger 7100 is used to recharge the battery (not shown) in the top 2620. In FIG. 116, the top 2620 is shown on the battery recharger 7100. The latches 6530 are shown closed, connecting the top 2620 to the battery recharger 7100. Thus, the latch 6530 used to connect a top portion 2620 to a base portion (not shown) is also used to connect the top 2620 to the battery recharger 7100. Docking may establish a direct power connection, or power may be transferred by way of inductive coupling. Also, in some embodiments of the system, the patient employs multiple non-disposable portions 2620 in rotation; i.e., recharging one non-disposable portion 2620, while using a second non-disposable portion (not shown).

The various embodiments described herein include different types and configurations of elements such as, for example, pump architectures, pump actuators, volume sensors, flow restrictors, reservoirs (and reservoir interfaces), sharps inserters, housings, latching mechanisms, user interfaces, on-board peripherals (e.g., controllers, processors, power sources, network interfaces, sensors), and other peripherals (e.g., hand-held remote controller, base station, repeater, filling station). It should be noted that alternative embodiments may incorporate various combinations of such elements. Thus, for example, a pump architecture described with reference to one embodiment (e.g., the pump shown and described with reference to FIGs. 15A-15D) may be used with any of the various configurations of pump actuators (e.g., single shape-memory actuator with single mode of operation, single shape-memory actuator with multiple modes of operation, multiple shape-memory actuators of the same size or different sizes), and may be used in devices with various combinations of other elements (or absence of other elements) and/or any of the various flow restrictors.

Furthermore, while various embodiments are described herein with reference to a non-pressurized reservoir, it should be noted that a pressurized reservoir may be used in certain embodiments or under certain conditions (e.g., during priming and/or air purging). Among other things, a pressurized reservoir might facilitate filling of the

pump chamber, for example, following retraction of the pump actuation member 54 shown and described with reference to FIGs. 15A-15D.

5 Additionally, while various embodiments are described herein with reference to a pump motor disposed in a reusable portion of a housing, it should be noted that a pump and/or a pump motor may alternatively be situated in the disposable portion, for example, along with various components that come into contact with the fluid. As with some of the other motors described herein, a motor disposed in the disposable portion may include one or more shape-memory actuators.

10

It should be noted that section headings are included for convenience and are not intended to limit the scope of the invention.

15

In various embodiments, the herein disclosed methods including those for controlling and measuring flow of a fluid and for establishing communication amongst linked components may be implemented as a computer program product for use with a suitable controller or other computer system (referred to generally herein as a “computer system”). Such implementations may include a series of computer instructions fixed either on a tangible medium, such as a computer readable medium (e.g., a diskette, CD-ROM, ROM, EPROM, EEPROM, or fixed disk) or transmittable to a computer system, via a modem or other interface device, such as a communications adapter connected to a network over a medium. The medium may be either a tangible medium (e.g., optical or analog communications lines) or a medium implemented with wireless techniques (e.g., microwave, infrared or other transmission techniques). The series of computer instructions may embody desired functionalities previously described herein with respect to the system. Those skilled in the art should appreciate that such computer instructions can be written in a number of programming languages for use with many computer architectures or operating systems.

25  
30

1062-E72WO-615996  
2/9/2007

Furthermore, such instructions may be stored in any memory device, such as semiconductor, magnetic, optical or other memory devices, and may be transmitted using any communications technology, such as optical, infrared, acoustic, radio, microwave, or other transmission technologies. It is expected that such a computer program product may be distributed as a removable medium with accompanying printed or electronic documentation (e.g., shrink wrapped software), preloaded with a computer system (e.g., on system ROM, EPROM, EEPROM, or fixed disk), or distributed from a server or electronic bulletin board over the network (e.g., the Internet or World Wide Web). Of course, some embodiments of the invention may be implemented as a combination of both software (e.g., a computer program product) and hardware. Still other embodiments of the invention are implemented as entirely hardware, or substantially in software (e.g., a computer program product).

It should be noted that dimensions, sizes, and quantities listed herein are exemplary, and the present invention is in no way limited thereto. In an exemplary embodiment of the invention, a patch-sized fluid delivery device may be approximately 6.35 cm (~2.5 in) in length, approximately 3.8 cm (~1.5 in) in width, and approximately 1.9 cm (~0.75 in) in height, although, again, these dimensions are merely exemplary, and dimensions can vary widely for different embodiments.

While the principles of the invention have been described herein, it is to be understood by those skilled in the art that this description is made only by way of example and not as a limitation as to the scope of the invention. Other embodiments are contemplated within the scope of the present invention in addition to the exemplary embodiments shown and described herein. Modifications and substitutions by one of ordinary skill in the art are considered to be within the scope of the present invention.

What is claimed is:

1. Apparatus comprising:

5 a patch-sized housing including a reusable portion and a disposable portion that is removably engageable with the reusable portion; wherein:

10 the disposable portion includes a substrate having flexible membrane material thereon and incorporating therein a fluid channel, the fluid channel being part of a fluid path in the disposable portion from a reservoir port to a cannula port and including a series of regions exposed to the flexible membrane material, at least one of such regions being a valve region; and

the reusable portion includes a control assembly having an active mechanical assembly that interacts mechanically with the regions through the membrane material in such a manner as to achieve pumping of fluid along the fluid path, the active mechanical assembly including a valve actuator operating on the valve region.

15 2. Apparatus according to claim 1, wherein the series of regions are exposed to a single flexible membrane of the flexible membrane material.

3. Apparatus according to claim 1, wherein the fluid path includes a fluid impedance downstream of the regions so as to prevent pumping of fluid along the path at an unsafe flow rate.

20 4. Apparatus according to claim 3, wherein the fluid impedance is a passive fluid impedance.

5. Apparatus according to claim 3, wherein the fluid impedance includes a tortuous conduit.

25 6. Apparatus according to claim 5, wherein the conduit is an integral part of the fluid channel.

7. Apparatus according to claim 5, wherein the conduit comprises coiled tubing.

8. Apparatus according to claim 7, wherein the coiled tubing includes at least two turns.

9. Apparatus according to claim 5, wherein the conduit has a serpentine shape.

10. Apparatus according to claim 5, wherein the conduit has a length greater than 2 cm.

30 11. Apparatus according to claim 5, wherein the conduit has a length greater than a largest dimension of the housing.

12. Apparatus according to claim 5, wherein the conduit includes an effective internal diameter selected to provide a predetermined impedance based on at least one of a viscosity and a density of the fluid.
13. Apparatus according to claim 5, wherein the conduit includes a length selected to provide a predetermined impedance based on at least one of a viscosity and a density of the fluid.
14. Apparatus according to claim 5, wherein the internal diameter of the conduit is sufficiently large to prevent occlusion due to flow of a therapeutic liquid through the conduit.
15. Apparatus according to claim 1, wherein the substrate includes a dispensing chamber formed in the fluid channel of the substrate, such chamber bounded by flexible membrane material forming a dispensing chamber membrane.
16. Apparatus according to claim 15, wherein the fluid path includes a finite fluid impedance downstream of the dispensing chamber, the fluid impedance sufficiently high so as to cause the expansion of the dispensing chamber membrane in response to the pumping of fluid induced by the active mechanical assembly.
17. Apparatus according to claim 16, wherein the control assembly includes at least a first pump mode in which the dispensing chamber is permitted to substantially empty between pump strokes and a second pump mode in which the dispensing chamber is not permitted to fully empty between pump strokes.
18. Apparatus according to claim 16, wherein the reusable portion includes a resilient dispensing spring positioned atop the dispensing chamber membrane to facilitate contraction of the dispensing chamber membrane.
19. Apparatus according to claim 18, wherein the dispensing spring includes one of a spiral shape, a fan shape, and multiple helical grooves.
20. Apparatus according to claim 16, wherein the dispensing chamber membrane includes a resilient dispensing spring to facilitate contraction of the dispensing chamber membrane.
21. Apparatus according to claim 15, wherein the control assembly includes a fluid sensor in communication with the dispensing chamber for measuring fluid flow through the dispensing chamber.

22. Apparatus according to claim 21, wherein the fluid sensor is an acoustic volume sensor.
23. Apparatus according to claim 22, wherein the acoustic volume sensor includes a loudspeaker, and wherein the loudspeaker is used by the control assembly for both  
5 acoustic volume sensing and audible alarm generation.
24. Apparatus according to claim 22, wherein the acoustic volume sensor includes a microphone, and wherein the microphone is used by the control assembly for both acoustic volume sensing and monitoring pump operation.
25. Apparatus according to claim 1, wherein the disposable portion further includes a  
10 pump region, and wherein the active mechanical assembly further includes a pump actuator operating on the pump region.
26. Apparatus according to claim 25, wherein the active mechanical assembly further includes a motor for operation of at least one of the valve actuator and the pump actuator under control of the control assembly.
- 15 27. Apparatus according to claim 26, wherein the active mechanical assembly includes a plate coupled to the valve actuator, the pump actuator, and the motor for coordinated operation of the valve actuator and the pump actuator.
28. Apparatus according to claim 27, wherein the valve region is positioned between the reservoir port and the pump region, and wherein operation of the valve actuator and the  
20 pump actuator is coordinated so as to prevent backflow of fluid toward the reservoir port.
29. Apparatus according to claim 26, wherein the motor includes a shape-memory actuator.
30. Apparatus according to claim 29, wherein the motor includes at least one pulley for folding the shape-memory actuator to fit within the reusable portion.
- 25 31. Apparatus according to claim 29, wherein the shape-memory actuator is operated through changes in heat, and wherein the motor includes a heater for operating the shape-memory actuator.
32. Apparatus according to claim 29, wherein the shape-memory actuator is operated through changes in electrical current passed through at least a portion of the shape-  
30 memory actuator.
33. Apparatus according to claim 32, wherein the shape-memory actuator is electrically

coupled so as to provide a plurality of electrical paths of different lengths through the shape-memory actuator.

34. Apparatus according to claim 33, wherein a shorter electrical path is used during normal operation of a pump and a longer electrical path is used during priming and air-purging of the pump.

35. Apparatus according to claim 26, wherein the motor includes a plurality of shape-memory actuators.

36. Apparatus according to claim 35, wherein the plurality of shape-memory actuators provide for redundant operation of the active mechanical assembly.

37. Apparatus according to claim 35, wherein different numbers of shape-memory actuators are used to provide different actuation forces or stroke lengths.

38. Apparatus according to claim 35, wherein the plurality of shape-memory actuators includes shape-memory actuators of at least two different lengths.

39. Apparatus according to claim 38, wherein a shorter shape-memory actuator is used during normal operation of a pump and a longer shape-memory actuator is used during priming and air-purging of the pump.

40. Apparatus according to claim 35, wherein the plurality of shape-memory actuators includes shape-memory actuators of at least two different gauges.

41. Apparatus according to claim 1, wherein the substrate and the flexible membrane material of the disposable portion constitute a fluidic assembly, and wherein the disposable portion further includes a disposable base into which the fluidic assembly fits.

42. Apparatus according to claim 41, further comprising an adhesive pad coupled to a bottom of the disposable base.

43. Apparatus according to claim 1, wherein the reservoir port includes a reservoir interface for coupling with a fluid reservoir.

44. Apparatus according to claim 43, wherein the reservoir interface includes a cannulated needle for introduction into the fluid reservoir so as to provide fluid communication between the fluid reservoir and the fluid path.

45. Apparatus according to claim 43, wherein the reservoir interface includes a septum for penetration by a fluid reservoir cannulated needle so as to provide fluid communication between the fluid reservoir and the fluid path.



46. Apparatus according to claim 1, wherein at least one of the reusable portion and the disposable portion includes a recess for receiving a fluid reservoir.
47. Apparatus according to claim 46, wherein the fluid reservoir is eccentrically shaped, and wherein the recess is similarly shaped so as to prevent incorrect orientation of the  
5 fluid reservoir within the housing.
48. Apparatus according to claim 1, wherein the reusable portion and the disposable portion include a latching mechanism for permitting selective engagement and disengagement of the reusable and disposable portions.
49. Apparatus according to claim 48, wherein the reusable portion includes at least one  
10 latch actuator for permitting selective coupling and decoupling of the reusable and disposable portions.
50. Apparatus according to claim 1, wherein the control assembly includes an electrical power source for providing electrical power to electronics in at least one of the reusable portion and the disposable portion.
- 15 51. Apparatus according to claim 50, wherein the electrical power source is a rechargeable battery.
52. Apparatus according to claim 51, wherein the control assembly further includes a battery recharging circuit for recharging the battery.
53. Apparatus according to claim 52, wherein the control assembly further includes a coil  
20 for inductively coupling the battery recharging circuit with an external power source for recharging the rechargeable battery.
54. Apparatus according to claim 50, wherein the control assembly further includes a backup electrical power source.
55. Apparatus according to claim 54, wherein the backup electrical power source  
25 includes at least one of a battery and a supercapacitor.
56. Apparatus according to claim 1, wherein the disposable portion includes an electrical power source for providing electrical power to electronics in at least one of the reusable portion and the disposable portion.
57. Apparatus according to claim 56, wherein the electrical power source includes at least  
30 one of a battery and a supercapacitor.
58. Apparatus according to claim 1, wherein the control assembly further includes a

network interface for communication with a remote controller.

59. Apparatus according to claim 58, wherein the network interface includes a wireless transceiver for wireless communication with the remote controller.

60. Apparatus according to claim 59, wherein the control assembly further includes a coil  
5 coupled to the wireless transceiver for conveying radio frequency signals to and from the wireless transceiver.

61. Apparatus according to claim 60, wherein the control assembly further includes a battery recharging circuit for recharging a rechargeable battery, wherein the coil is further  
10 coupled to the battery recharging circuit for inductively coupling the battery recharging circuit with an external power source.

62. Apparatus according to claim 58, wherein the network interface includes a communication interface for wired communication with the remote controller.

63. Apparatus according to claim 58, wherein the control assembly receives configuration information from the remote controller and sends status information to the remote  
15 controller via the network interface.

64. Apparatus according to claim 1, further comprising a speaker disposed in one of the reusable portion and the disposable portion for audible alarm generation.

65. Apparatus according to claim 1, further comprising a vibrating mechanism disposed in the reusable portion for at least one of audible and tactile alarm generation.

20 66. Apparatus according to claim 1, further comprising a vibrating mechanism disposed in the disposable portion for at least one of audible alarm generation, tactile alarm generation, and insertion of a needle.

67. Apparatus according to claim 1, further comprising a microphone disposed in one of the reusable portion and the disposable portion for monitoring operation of the active  
25 mechanical assembly.

68. Apparatus according to claim 1, further comprising a temperature sensor disposed in one of the reusable portion and the disposable portion for providing temperature information to the control assembly.

69. Apparatus according to claim 68, wherein the temperature sensor is one of an ambient  
30 temperature sensor and a skin temperature sensor.

70. Apparatus according to claim 1, wherein the control assembly is operably coupled to

generate an alarm to indicate an operational condition.

71. Apparatus according to claim 70, wherein the alarm includes at least one of an audible alarm, a visual alarm, a tactile alarm, and a wireless alarm signal.

72. Apparatus according to claim 70, wherein the operational condition includes at least one of a power on condition, proper operation of the control assembly, and proper delivery of fluid within a predetermined set of parameters.

73. Apparatus according to claim 1, wherein the control assembly is operably coupled to generate an alarm to indicate a fault condition.

74. Apparatus according to claim 73, wherein the alarm includes at least one of an audible alarm, a visual alarm, a tactile alarm, and a wireless alarm signal.

75. Apparatus according to claim 73, wherein the fault condition includes at least one of a low power level, a low fluid level, an abnormal temperature level, a problem with a primary or backup power supply, detection of an occlusion, detection of an air bubble, detection of a fluid leak, decoupling of the reusable portion and the disposable portion, communication failure between the reusable portion and the disposable portion, expiration of the disposable portion, attempted re-use of the disposable portion, detection of abnormal vibration from the pump, and detection of lack of vibration from the pump.

76. Apparatus according to claim 1, wherein the disposable portion includes a processor for at least one of continuing device operation in the event of a failure, generating an alarm to indicate that a failure has occurred, and providing status information to the control assembly.

77. Apparatus according to claim 76, wherein the status information includes at least one of operational history of the disposable portion, characteristics of the disposable portion, and usage information.

78. Apparatus according to claim 76, wherein the control assembly is operably coupled to selectively prevent operation of the active mechanical assembly and generate an alarm based on the status information received from the processor.

79. Apparatus according to claim 1, wherein the control assembly includes a user input, operable from outside of the housing, for actuating the mechanical assembly to deliver a predetermined quantity of fluid.

80. Apparatus according to claim 79, wherein the predetermined quantity is

programmable.

81. Apparatus according to claim 79, wherein the predetermined quantity is delivered as a single bolus.

5 82. Apparatus according to claim 79, wherein the predetermined quantity is delivered as a plurality of pulses.

83. Apparatus according to claim 79, wherein the user input includes a manual control, accessible from outside of the housing, for manual actuation of the mechanical assembly.

84. Apparatus according to claim 79, wherein the user input includes a network interface for remote actuation of the mechanical assembly from a remote controller.

10 85. Apparatus according to claim 79, wherein the control assembly is operably coupled to generate an alert upon attempted actuation of the mechanical assembly via the user input and to require a user confirmation before actuating the mechanical assembly to deliver the predetermined quantity of fluid.

15 86. Apparatus according to claim 85, wherein the alert includes at least one of an audible alert, a visual alert, a tactile alert, and a query provided from a remote controller.

87. Apparatus according to claim 79, wherein the control assembly is operably coupled to generate an alert after completing delivery of the predetermined quantity of fluid.

20 88. Apparatus according to claim 1, wherein the disposable portion is configured to support a cannulus in fluid communication with the fluid path and an analyte sensor in communication with the control assembly.

89. Apparatus according to claim 88, wherein interconnection between the control assembly and the analyte sensor is established upon engagement of the reusable portion and the disposable portion.

25 90. Apparatus according to claim 89, wherein the control assembly includes an analyte sensor interface for direct interconnection with the analyte sensor.

91. Apparatus according to claim 1, further comprising at least one pad for situation between an underside of the disposable portion and a patient's skin so as to provide separation between the disposable portion and a patient's skin.

30 92. Apparatus according to claim 91, wherein the at least one pad is secured to the underside of the disposable portion.

93. Apparatus according to claim 92, wherein the at least one pad includes adhesive for

securing the disposable portion to the patient's skin.

94. Apparatus according to claim 91, wherein the at least one pad is placed loosely between the underside of the disposable portion and the patient's skin.

5 95. Apparatus according to claim 91, wherein the at least one pad is configured to provide for air flow to a portion of the patient's skin covered by the disposable portion when placed on the patient.

96. Apparatus according to claim 95, wherein air flow is provided by at least one of passageways through the pad, passageways between pads, and construction of the at least one pad from a porous material.

10 97. Apparatus according to claim 1, further comprising an adhesion system for affixation of the housing to a human body, the system comprising:

a first set of three or more members, each member including an adhesive material on at least one side so as to attach to the body upon application of pressure, the members disposed around a central region; and

15 a second set of three or more members, each member including an adhesive material on at least one side so as to attach to the body upon application of pressure, the members disposed around the central region,

wherein the members of the first set are spaced to allow the members of the second set to attach to the body in spaces provided between the members of the first set, and wherein the members of the second set spaced to allow members of the first set to  
20 detach from the body without detaching the members of the second set.

98. Apparatus according to claim 97, wherein at least one member is perforated so as to allow facile tearing off of the member.

99. Apparatus according to claim 97, further including at least one peelable backing strip.

25 100. Apparatus according to claim 97, wherein the members of the first set are a first color and the members of the second set are a second color different from the first color.

101. Apparatus according to claim 1, further comprising a plurality of tethers coupled to the housing and a plurality of adhesive members for securing the tethers to a patient's skin.

30 102. A disposable unit for a patch-sized fluid delivery device, the disposable unit removably engageable with a corresponding reusable unit, the disposable unit including a

substrate having flexible membrane material thereon and incorporating therein a fluid channel, the fluid channel being part of a fluid path in the disposable unit from a reservoir port to a cannula port and including a series of regions exposed to the flexible membrane material, at least one of such regions being a valve region, so that an active mechanical assembly in the reusable portion can interact mechanically with the regions through the

5 membrane material in such a manner as to achieve pumping of fluid along the fluid path, the active mechanical assembly including a valve actuator operating on the valve region.

103. A disposable unit according to claim 102, wherein the series of regions are exposed to a single flexible membrane of the flexible membrane material.

104. A disposable unit according to claim 102, further including a fluid impedance in the fluid path downstream of the regions to as to prevent pumping of fluid along the fluid path at an unsafe flow rate.

105. A disposable unit according to claim 104, wherein the fluid impedance includes at least one of a tortuous conduit that is an integral part of the fluid channel and tubing that

15 is in fluid communication with the fluid channel.

106. A disposable unit according to claim 102, wherein the substrate includes a dispensing chamber formed in the fluid channel of the substrate, such chamber bounded by flexible membrane material forming a dispensing chamber membrane.

107. A disposable unit according to claim 106, wherein the dispensing chamber

20 membrane includes a resilient dispensing spring to facilitate contraction of the dispensing chamber membrane.

108. A disposable unit according to claim 102, further including a pump region for operation by a corresponding pump actuator in the reusable unit through the flexible membrane material.

109. A disposable unit according to claim 102, wherein the substrate and the flexible membrane material constitute a fluidic assembly, and wherein the disposable unit further includes a disposable base into which the fluidic assembly fits.

110. A disposable unit according to claim 109, further comprising an adhesive pad coupled to a bottom of the disposable base.

111. A disposable unit according to claim 102, wherein the reservoir port includes a reservoir interface for coupling with a fluid reservoir, the reservoir port including one of

a needle for introduction into the fluid reservoir and a septum for penetration by a fluid reservoir needle so as to provide fluid communication between the fluid reservoir and the fluid path.

5 112. A disposable unit according to claim 102, further including a latching mechanism for permitting selective engagement and disengagement with the reusable unit.

113. A disposable unit according to claim 102, further including an electrical power source for providing electrical power to electronics in at least one of the reusable unit and the disposable unit.

10 114. A disposable unit according to claim 102, further including at least one output selected from the group consisting of an audible output, a visual output, a tactile output, and a wireless output.

115. A disposable unit according to claim 102, configured for at least one of inserting and supporting a cannulus for fluid communication with the fluid path and an analyte sensor for communication with a control assembly of the reusable unit.

15 116. A disposable unit according to claim 102, further including a mechanism for attaching the disposable unit to a patient.

20 117. A disposable unit according to claim 116, further including a processor for at least one of continuing device operation in the event of a failure, generating an alarm to indicate that a failure has occurred, and providing status information to the reusable portion.

25 118. A reusable unit for a patch-sized fluid delivery device, the reusable unit removably engageable with a corresponding disposable unit including a substrate having a flexible material thereon and incorporating a fluid channel, the reusable unit including a control assembly having an active mechanical assembly that interacts mechanically with regions of the fluid channel in the substrate, including a valve region, through the flexible membrane material in such a manner as to achieve pumping of fluid along a fluid path including the fluid channel, the active mechanical assembly including a valve actuator for operating on the valve region.

30 119. A reusable unit according to claim 118, wherein the disposable unit includes a dispensing chamber bounded by flexible membrane material, and wherein the reusable unit includes a fluid sensor for communication with the dispensing chamber for

measuring fluid flow through the dispensing chamber.

120. A reusable unit according to claim 119, further including a resilient dispensing spring positioned so as to facilitate contraction of the dispensing chamber membrane.

5 121. A reusable unit according to claim 119, wherein the fluid sensor is an acoustic volume sensor.

122. A reusable unit according to claim 121, wherein the acoustic volume sensor includes a loudspeaker, and wherein the loudspeaker is used by the control assembly for both acoustic volume sensing and audible alarm generation.

10 123. A reusable unit according to claim 121, wherein the acoustic volume sensor includes a microphone, and wherein the microphone is used by the control assembly for both acoustic volume sensing and monitoring pump operation.

124. A reusable unit according to claim 118, wherein the disposable unit includes a pump region bounded by flexible membrane material, and wherein the reusable unit includes a pump actuator for operating on the pump region through the flexible membrane material.

15 125. A reusable unit according to claim 124, wherein the active mechanical assembly further includes a motor for operation of at least one of the valve actuator and the pump actuator under control of the control assembly, the motor including at least one shape-memory actuator.

20 126. A reusable unit according to claim 118, further including a latching mechanism for permitting selective engagement and disengagement with the disposable unit.

127. A reusable unit according to claim 118, wherein the control assembly includes at least one electrical power source for providing electrical power to electronics in at least one of the reusable unit and the disposable unit.

25 128. A reusable unit according to claim 127, wherein the control assembly further includes a battery recharging circuit for recharging a battery and a mechanism for providing electrical power to the battery recharging circuit.

129. A reusable unit according to claim 118, wherein the control assembly further includes a network interface for communication with a remote controller.

30 130. A reusable unit according to claim 118, wherein the control assembly further includes at least one alarm output selected from the group consisting of an audible output, a visual output, a tactile output, and a wireless output.



131. A reusable unit according to claim 118, wherein the control assembly further includes a temperature sensor capable of sensing at least one of ambient temperature and skin temperature.

132. A reusable unit according to claim 118, wherein the control assembly includes a user input for user actuation of the mechanical assembly to deliver a predetermined quantity of fluid.

133. A reusable unit according to claim 118, wherein the control assembly is operably coupled to selectively prevent operation of the active mechanical assembly and generate an alarm based on a status of the disposable portion.

134. Apparatus comprising a patch-sized housing and an active mechanical assembly disposed within the housing, the active mechanical assembly including a mechanical pump and a motor for operation of the mechanical pump, the motor including a plurality of actuators, each capable of operating the pump independently of the other actuators so as to provide for redundancy in the event of failure an actuator.

135. Apparatus according to claim 134, wherein the redundant actuators include at least one shape-memory actuator.

136. Apparatus according to claim 135, wherein the motor includes at least one pulley for folding the shape-memory actuator to fit within the reusable portion.

137. Apparatus according to claim 135, wherein the shape-memory actuator is operated through changes in heat, and wherein the motor includes a heater for operating the shape-memory actuator.

138. Apparatus according to claim 135, wherein the shape-memory actuator is operated through changes in electrical current passed through at least a portion of the shape-memory actuator.

139. Apparatus according to claim 138, wherein the shape-memory actuator is electrically coupled so as to provide a plurality of electrical paths of different lengths through the shape-memory actuator.

140. Apparatus according to claim 139, wherein a shorter electrical path is used during normal operation of a pump and a longer electrical path is used during priming and air-purging of the pump.

141. Apparatus according to claim 135, wherein the at least one shape-memory actuator

includes a plurality of shape-memory actuators.

142. Apparatus according to claim 141, wherein different numbers of shape-memory actuators are used to provide different actuation forces or stroke lengths.

5 143. Apparatus according to claim 141, wherein the plurality of shape-memory actuators includes shape-memory actuators of at least two different lengths.

144. Apparatus according to claim 143, wherein a shorter shape-memory actuator is used during normal operation of a pump and a longer shape-memory actuator is used during priming and air-purging of the pump.

10 145. Apparatus according to claim 141, wherein the plurality of shape-memory actuators includes shape-memory actuators of at least two different gauges.

146. Apparatus comprising a patch-sized housing enclosing a fluid delivery assembly and a plurality of electrical power sources for providing electrical power to the fluid delivery assembly.

15 147. Apparatus according to claim 146, wherein the housing includes a reusable portion and a disposable portion that is removably engageable with the reusable portion, and wherein the plurality of electrical power sources are disposed in the reusable portion.

148. Apparatus according to claim 146, wherein the housing includes a reusable portion and a disposable portion that is removably engageable with the reusable portion, and wherein the plurality of electrical power sources are disposed in the disposable portion.

20 149. Apparatus according to claim 146, wherein the housing includes a reusable portion and a disposable portion that is removably engageable with the reusable portion, and wherein each portion includes at least one electrical power source.

150. Apparatus according to claim 146, wherein the plurality of electrical power sources include a primary electrical power source and a backup electrical power source.

25 151. Apparatus according to claim 150, wherein the primary electrical power source is a rechargeable battery, and wherein the backup electrical power source is one of a battery and a supercapacitor.

30 152. Apparatus comprising a patch-sized housing enclosing a fluid delivery system, the fluid delivery system including a controller and a plurality of outputs in communication with the controller, the controller operably coupled generate an alarm through actuation of the plurality of outputs.

153. Apparatus according to claim 152, wherein the plurality of outputs are selected from the group consisting of an audible output, a visual output, a tactile output, and a wireless output.

5 154. Apparatus according to claim 152, wherein the alarm indicates at least one of an operational condition and a fault condition.

155. Apparatus according to claim 154, wherein the operational condition includes at least one of a power on condition, proper operation of the control assembly, and proper delivery of fluid within a predetermined set of parameters.

10 156. Apparatus according to claim 154, wherein the fault condition includes at least one of a low power level, a low fluid level, an abnormal temperature level, a problem with a primary or backup power supply, detection of an occlusion in the fluid path, detection of an air bubble in the fluid path, detection of a fluid leak, decoupling of the reusable portion and the disposable portion, communication failure between the reusable portion and the disposable portion, expiration of the disposable portion, attempted re-use of the  
15 disposable portion, detection of abnormal vibration from the pump, and detection of lack of vibration from the pump.

157. Apparatus comprising a patch-sized housing including a reusable portion and a disposable portion that is removably engageable with the reusable portion, the reusable portion including a control assembly having an active mechanical assembly for use in  
20 pumping fluid along a fluid path, the disposable portion including at least one attribute discernable by the control assembly, wherein the control assembly is operably coupled to selectively prevent operation of the active mechanical assembly and generate an alarm based on the at least one attribute.

25 158. Apparatus according to claim 157, wherein the attribute includes at least one of an operational history of the disposable portion, a characteristic of the disposable portion, and an attribute for usage of the disposable portion.

159. Apparatus according to claim 157, wherein the disposable portion includes a processor for providing attribute information to the control assembly.

30 160. Apparatus comprising a patch-sized housing including a reusable portion and a disposable portion that is removably engageable with the reusable portion, the reusable portion including a main controller, the disposable portion including a backup controller

capable of at least one of continuing an operation normally provided by the main controller and generating an alarm to indicate a failure of the main controller.

161. Apparatus comprising a patch-sized housing enclosing a fluid delivery system, the fluid delivery system including a controller and a user interface in communication with  
5 the controller, wherein the controller is operably coupled to control delivery of fluid to a patient and to test and report responsiveness of the patient via the user interface.

162. A wearable device for parenteral delivery of fluid, the device having at least a reservoir, a pump having a motor, and an exit assembly, and separable reusable and disposable portions, wherein the motor resides in the disposable portion.

10 163. A device according to claim 162 wherein all wetted parts reside in the disposable portion.

164. A device according to claim 162 wherein the motor uses a shape-memory material to convert a source of potential energy into kinetic energy.

165. A system for pumping fluid to a subject, the system comprising:

15 a first separable component including

an inlet fluid path in communication with a fluid source;

a pumping chamber for receiving fluid from the inlet fluid path;

a dispensing chamber for receiving fluid from the pumping chamber;

an outlet fluid path for carrying fluid from the dispensing chamber to

20 an exit assembly; and

a second separable component including

a force application assembly for compressing the pumping chamber, and

means for sensing flow conditions through the line.

166. A system according to claim 165, wherein the force application assembly causes  
25 flow of fluid to the pumping chamber from the inlet fluid path to be restricted while urging fluid from the pumping chamber to the dispensing chamber.

167. A system according to claim 165, wherein the first separable component further includes a reservoir as a fluid source.

168. A base sled for holding separable components of a device for delivery of a  
30 therapeutic fluid, the device comprising:

a bottom adapted for adhesion to the skin of a patient;

a fluidic path portion having a pumping chamber and an outlet; and  
a groove for securely receiving one or more of a fluid cannula and a probe  
cannula,

wherein the sled is adapted to receive a disposable insulin cartridge and a reusable  
5 portion.

169. A sled according to claim 168 further including three or more adhesive members for  
adhesive attachment to the skin of the patient, the members disposed around a central  
region; and an attachment means for joining the adhesive members to the device.

170. A sled according to claim 168, wherein the reusable portion include a component  
10 selected from the group consisting of: a flow sensor, an assembly for application of force  
to the pumping chamber, a power source, transceiver electronics, a microprocessor, and  
an alarm.

171. A sled according to claim 168, further including a mating feature for the attachment  
of a fluid reservoir.

15 172. A sled according to claim 171, wherein the mating feature is a septum.

173. A sled according to claim 171, wherein the mating feature is a needle

174. A sled according to claim 168, further including leads for the establishment of signal  
communication between a probe attached to the probe cannula and the reusable portion.

175. An irregularly shaped fluid reservoir adapted for holding a supply of a therapeutic  
20 fluid within a patch-sized housing having a correspondingly shaped reservoir holding  
chamber, the fluid reservoir having a cavity defined by a rigid reservoir body and a  
flexible reservoir membrane that is sealingly attached to the rigid reservoir body around  
the periphery of the cavity, the flexible reservoir membrane including at least one portion  
that collapses as therapeutic fluid is withdrawn, the irregular shapes of the fluid reservoir  
25 and the corresponding reservoir holding chamber providing for proper orientation of the  
fluid reservoir within the reservoir holding chamber.

176. A reservoir according to claim 175, further including a port through which the  
reservoir can be placed in fluid communication with a corresponding fluid path in the  
housing.

30 177. A reservoir according to claim 176, wherein the port includes one of a septum for  
penetration by a fluid path needle and a needle for introduction into the fluid path for

providing fluid communication between the reservoir and the fluid path.

178. A reservoir according to claim 176, wherein the port is seated in a neck extending from a reservoir body.

+

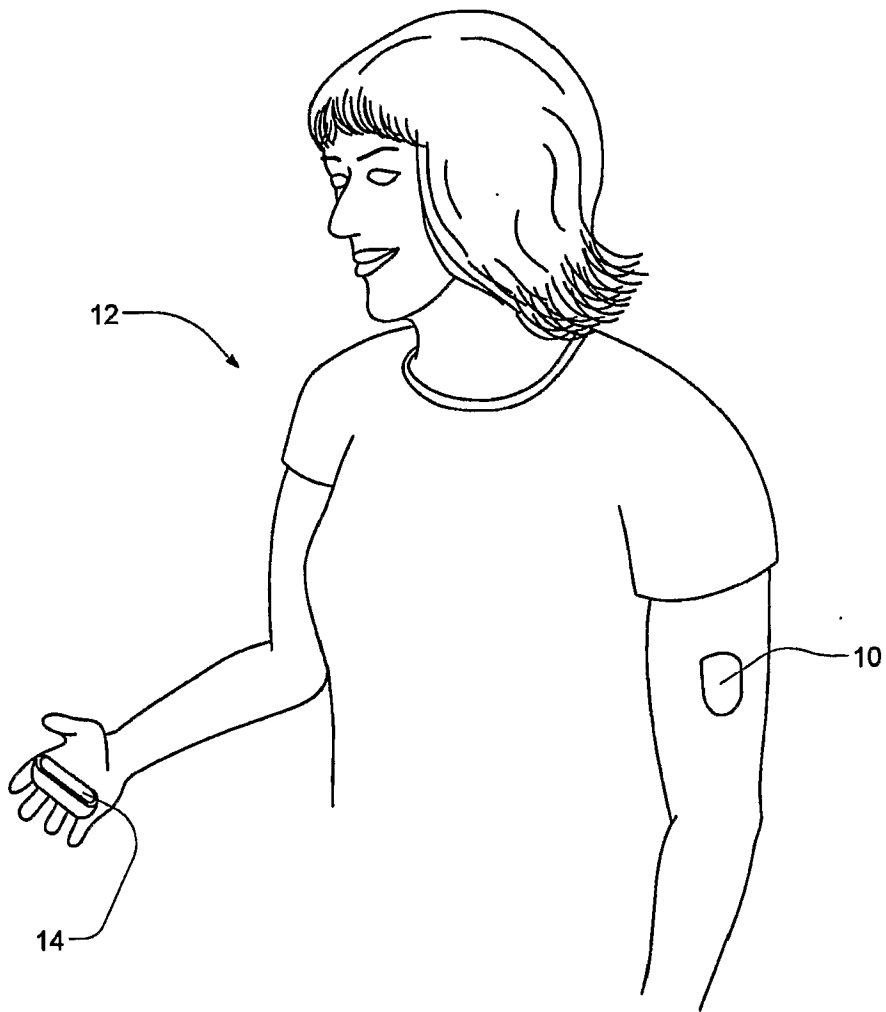

FIG. 1

+

+

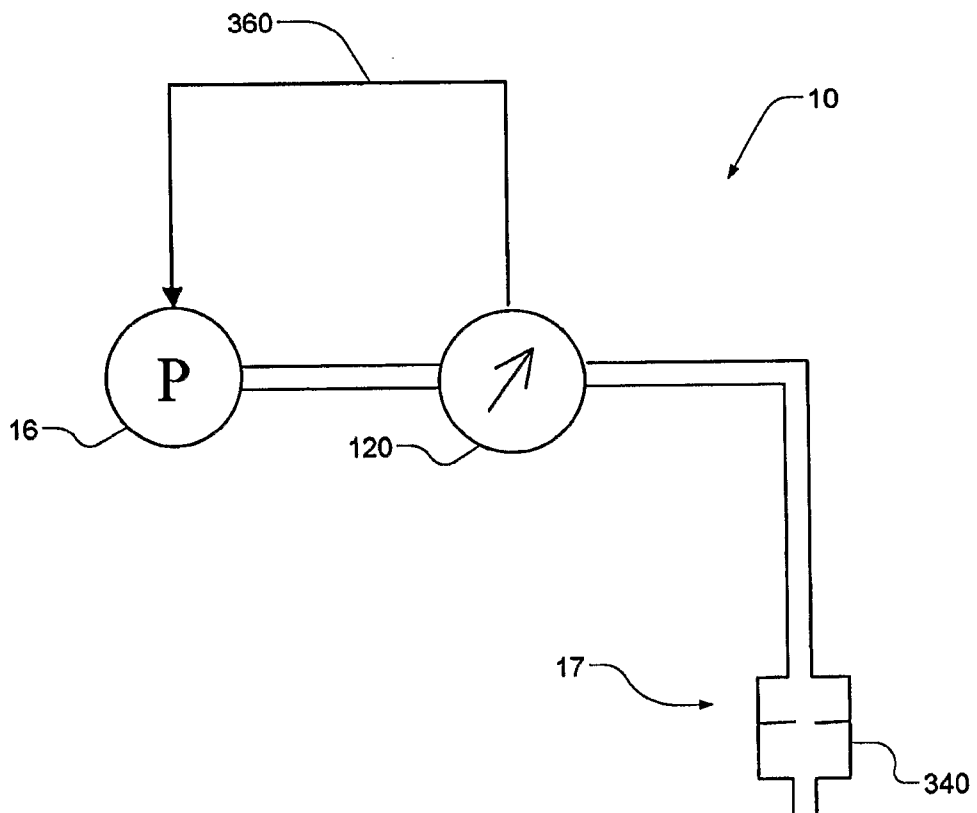

FIG. 2A

+



+

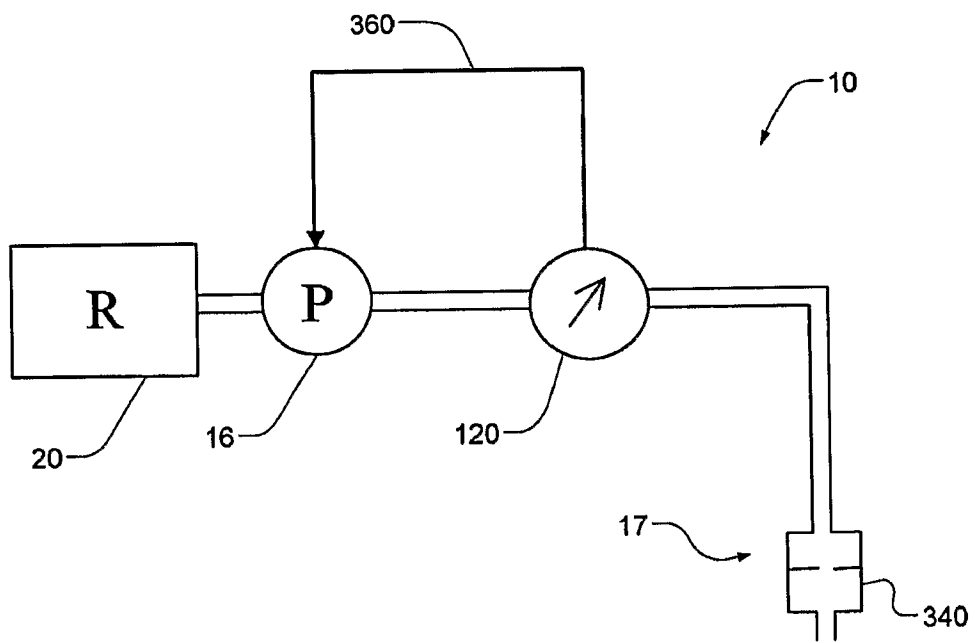

FIG. 2B

+

+

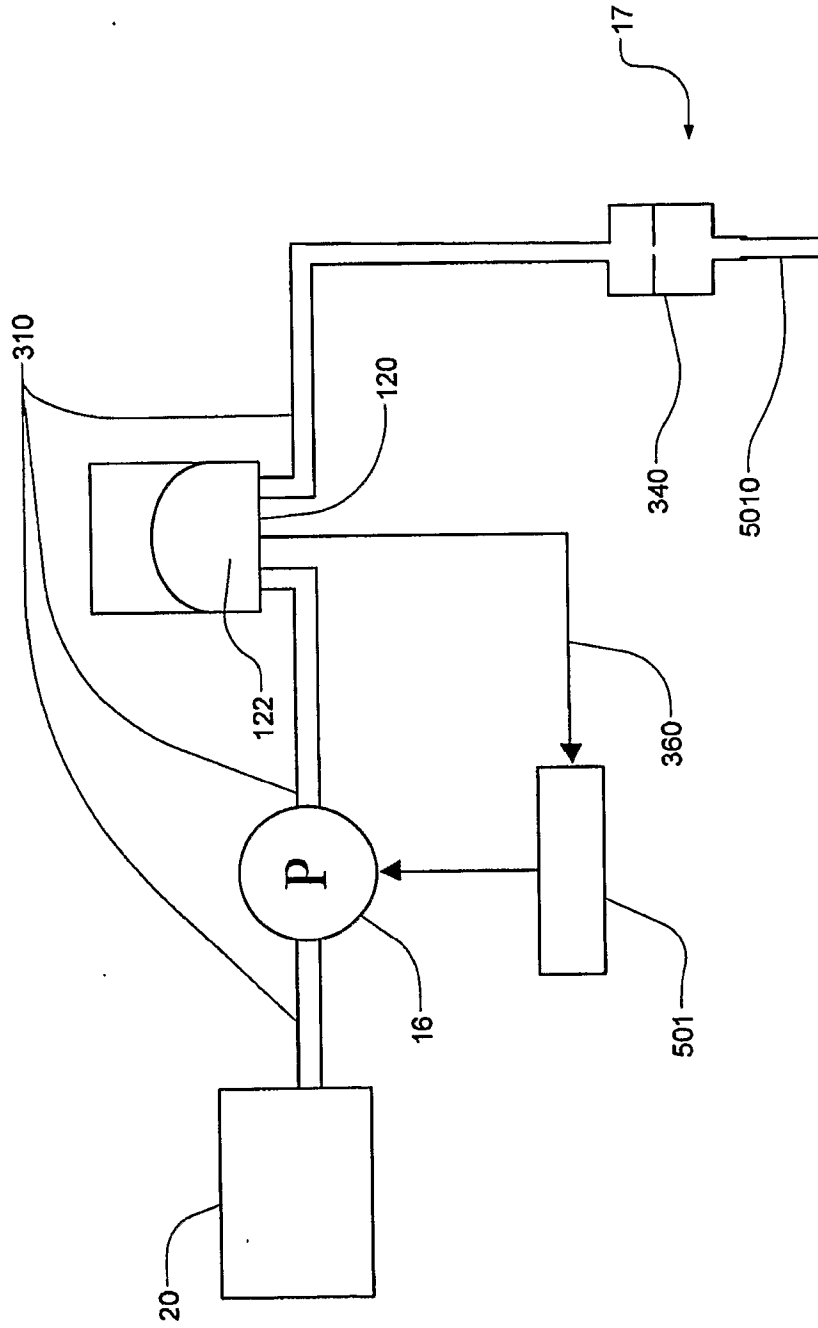

FIG. 3

+

+

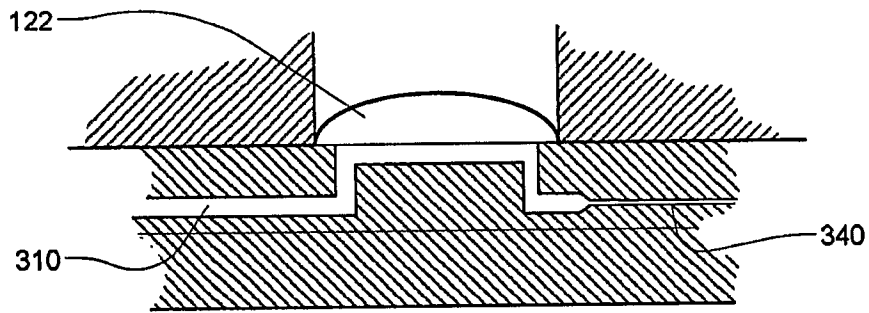

FIG. 4A

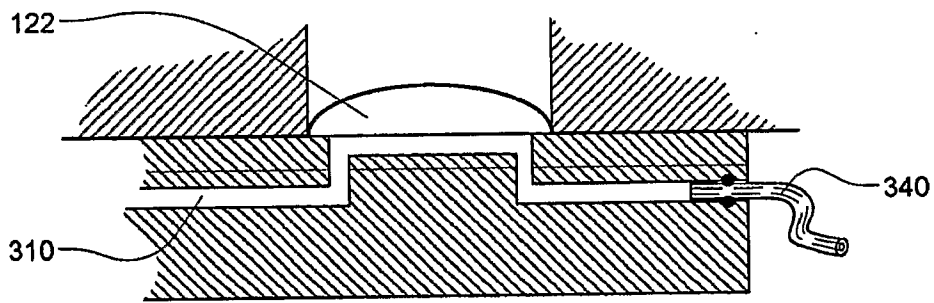

FIG. 4B

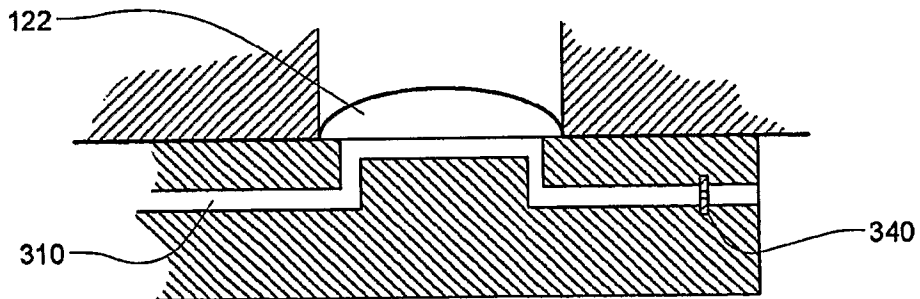

FIG. 4C

+

+

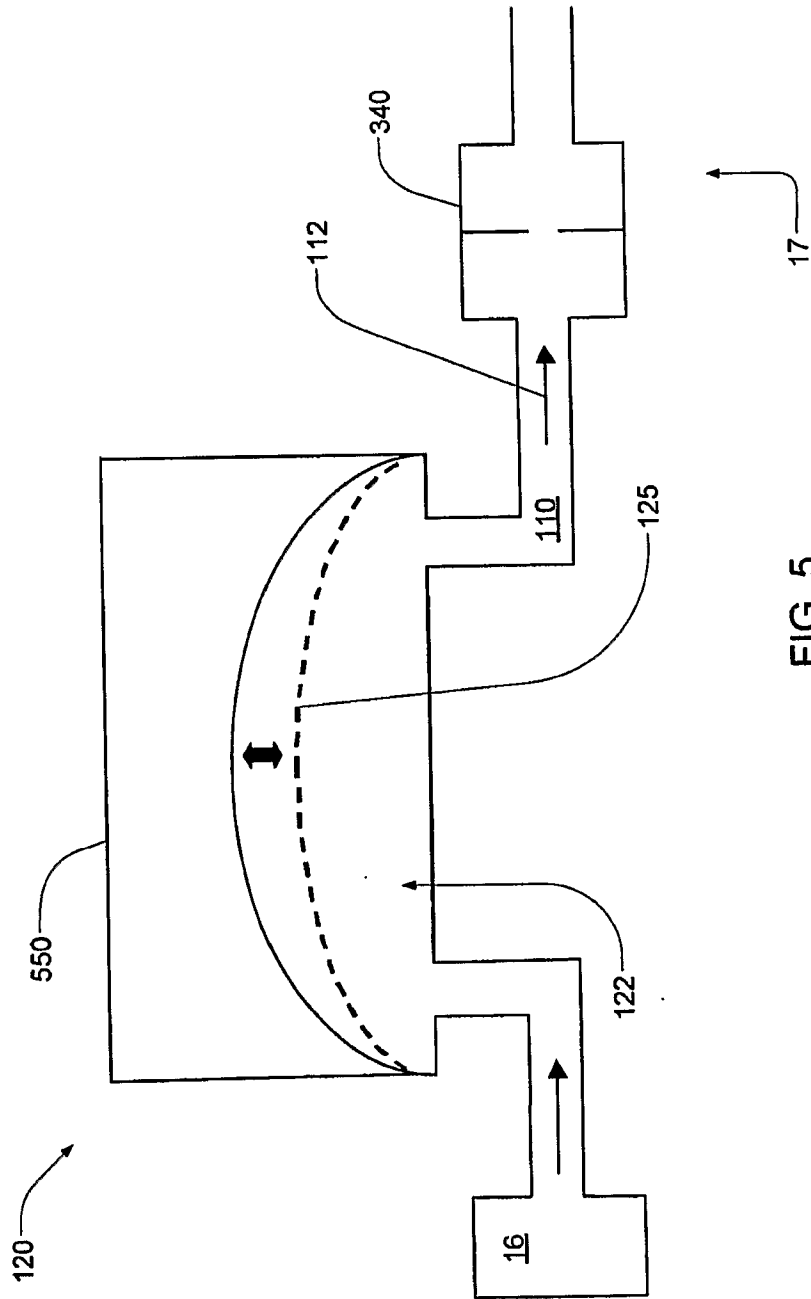

FIG. 5

+

+

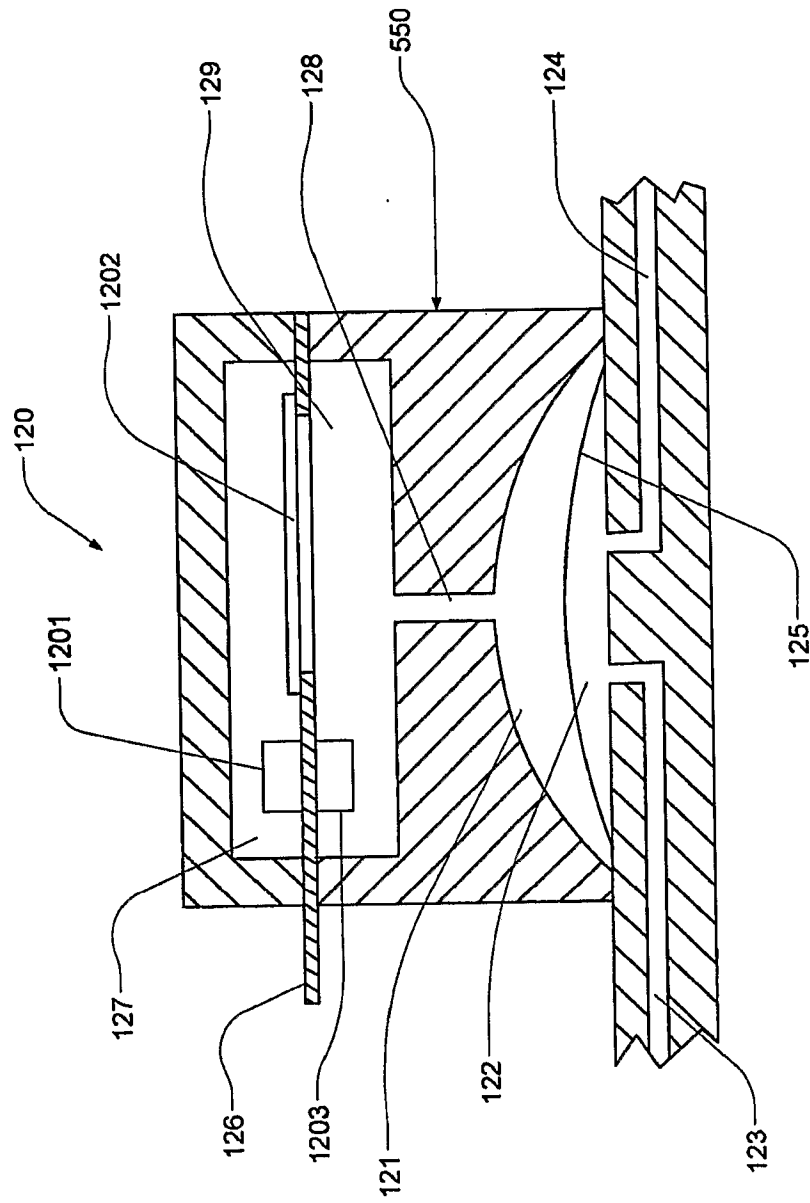

FIG. 6

+

+

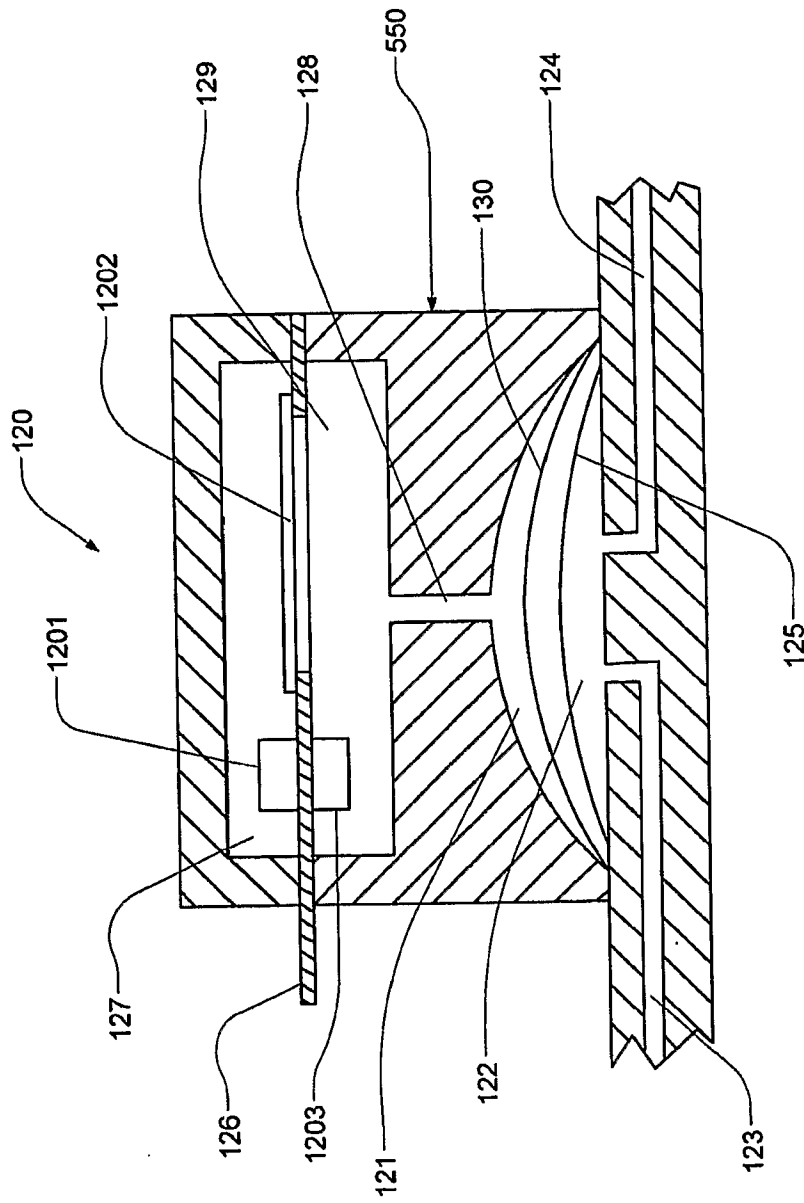

FIG. 7

+

+

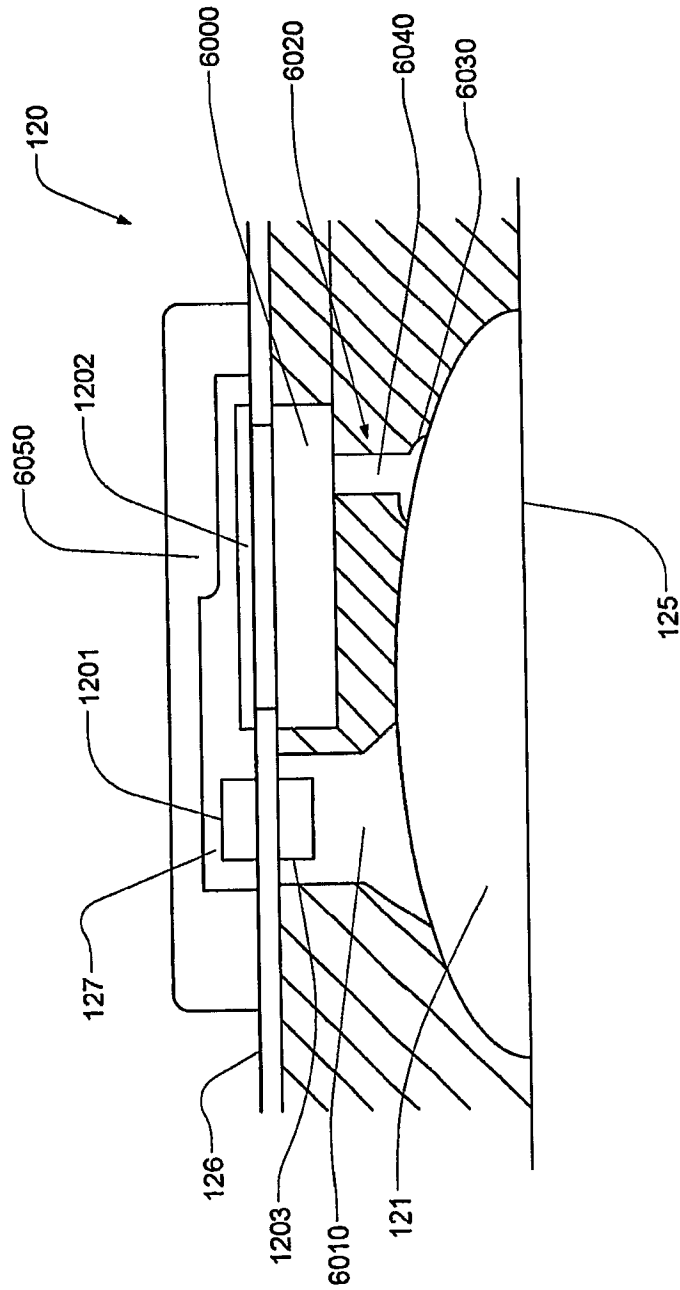

FIG. 8

+

+

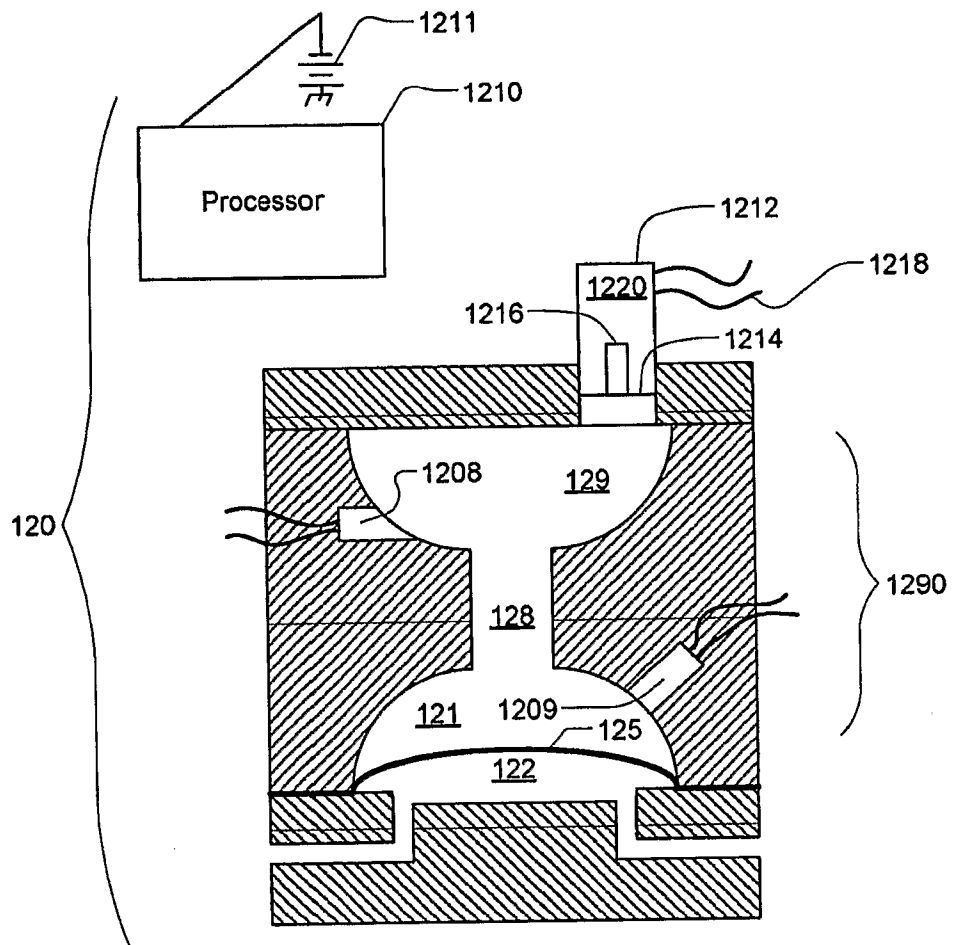

FIG. 9

+



+

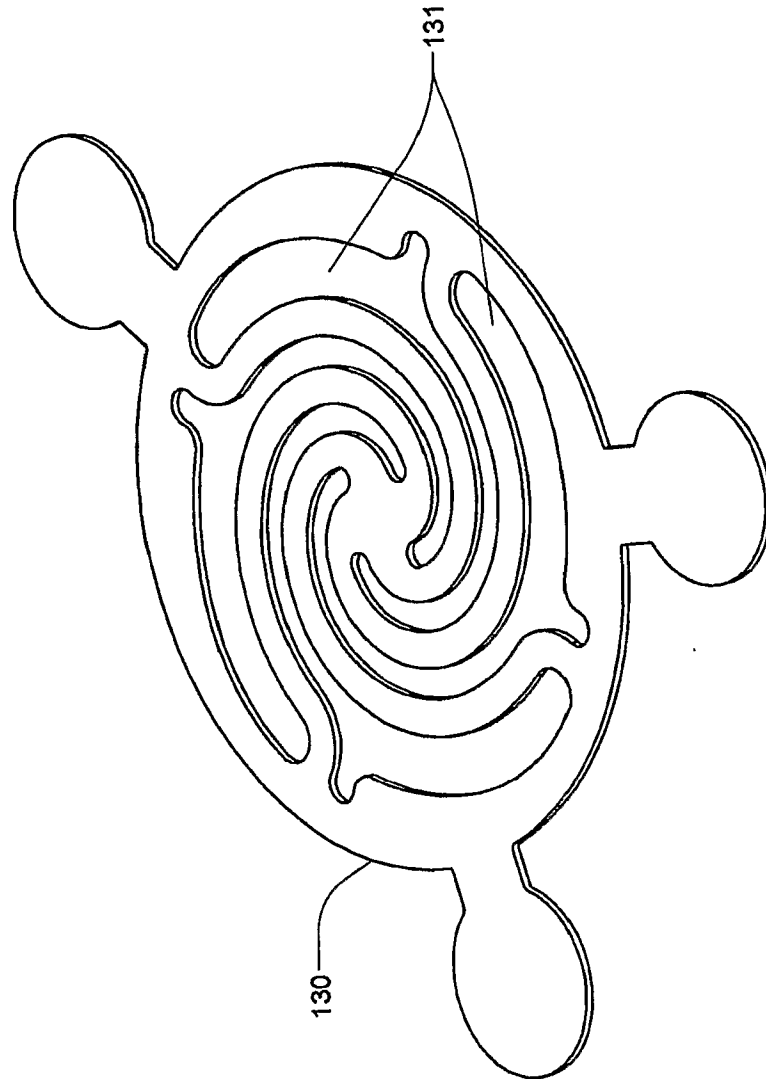

FIG. 10

+

+

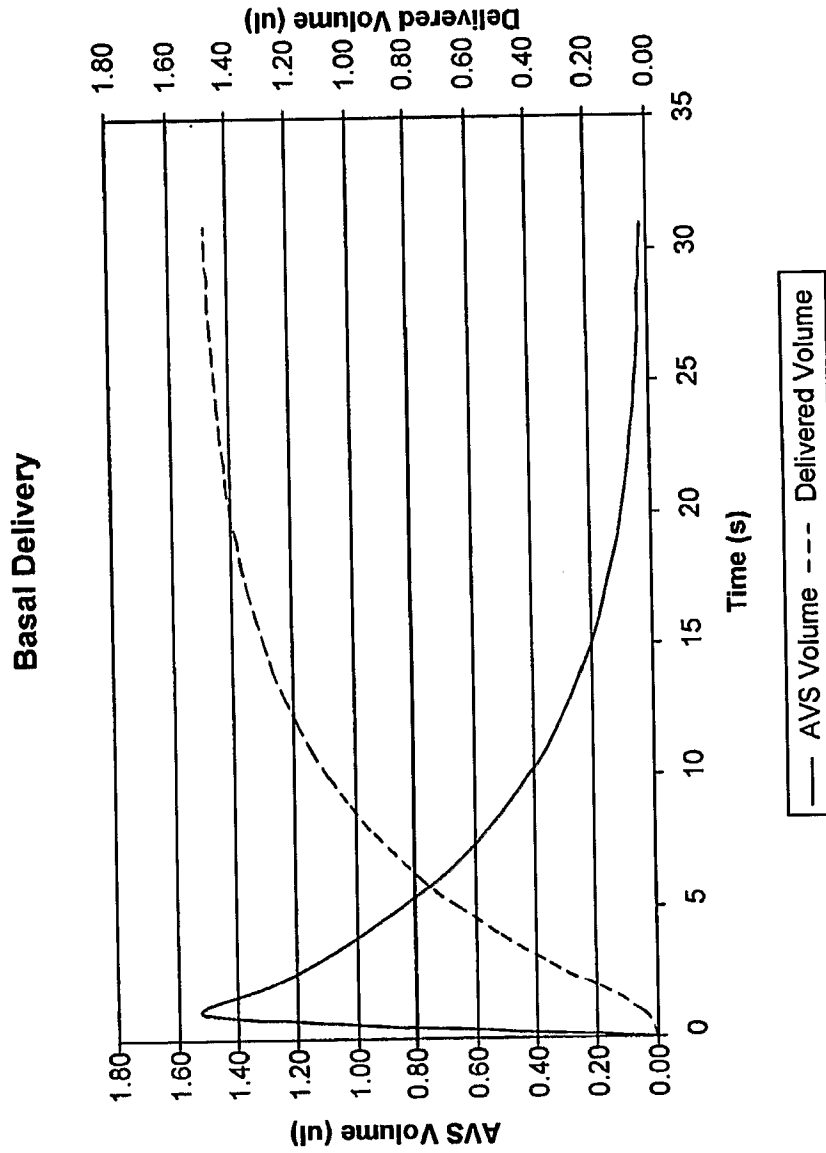

FIG. 11A

+

+

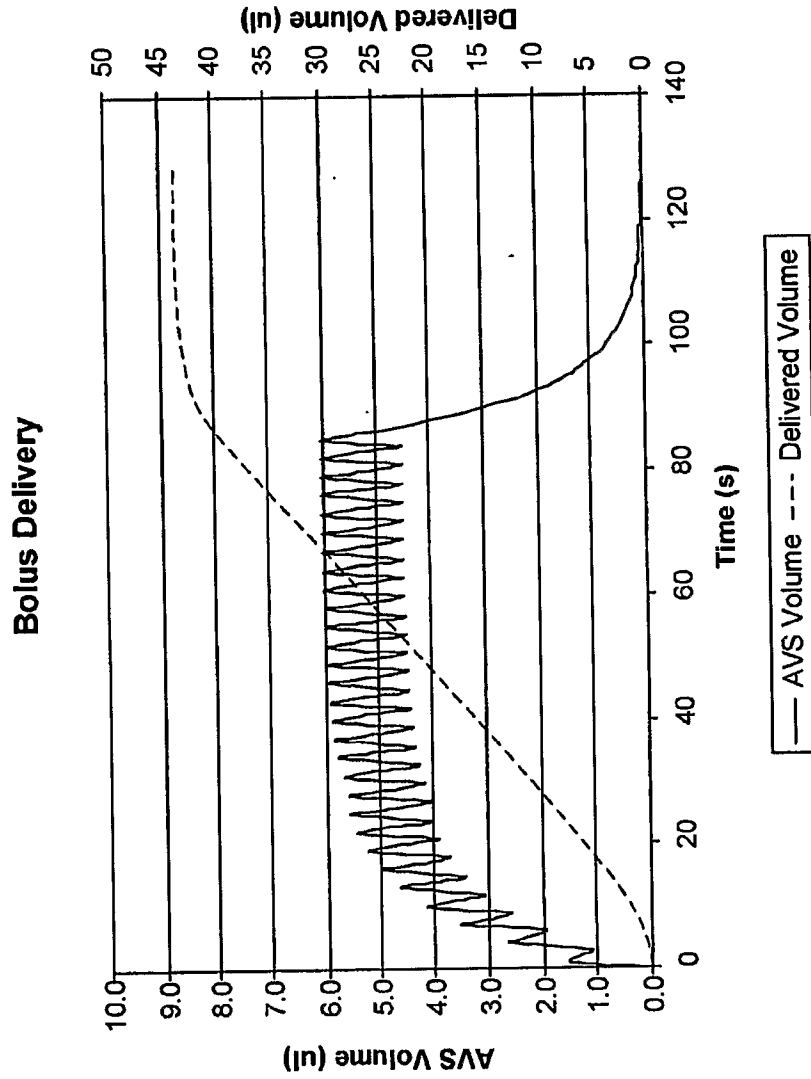

FIG. 11B

+

+

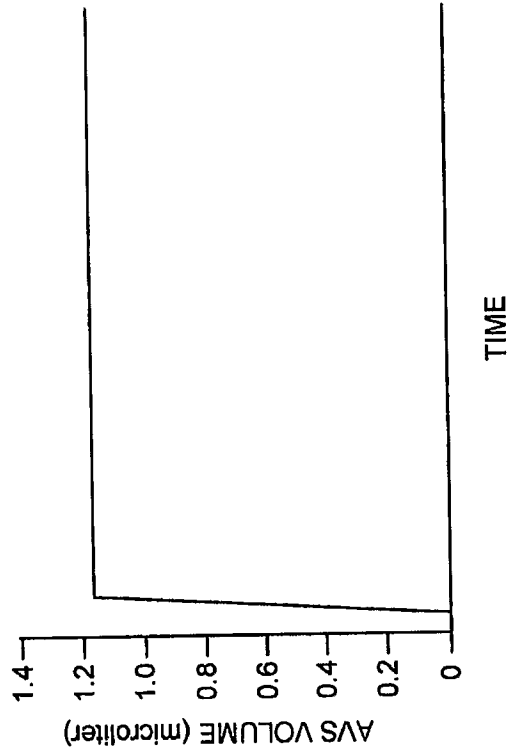

FIG. 11D

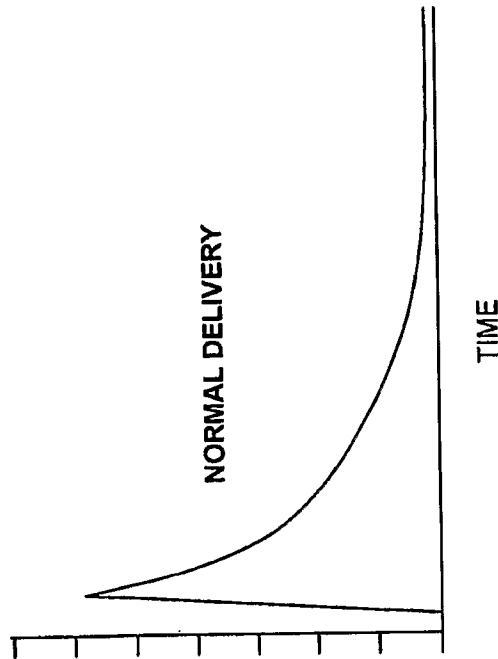

FIG. 11C

+

+

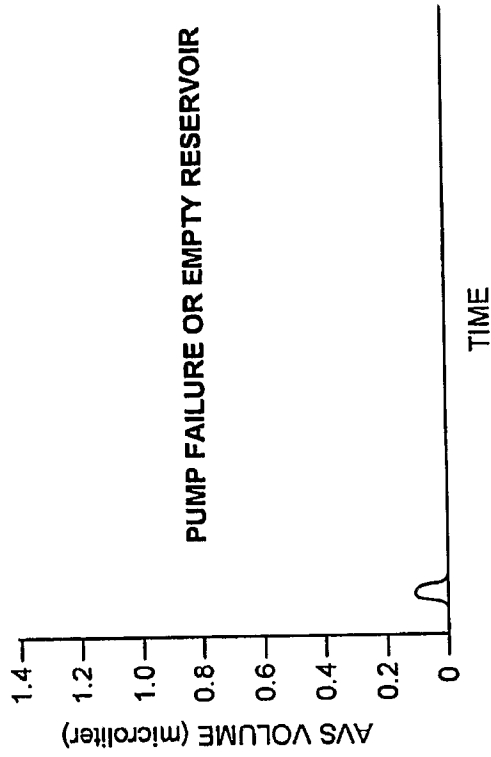

FIG. 11F

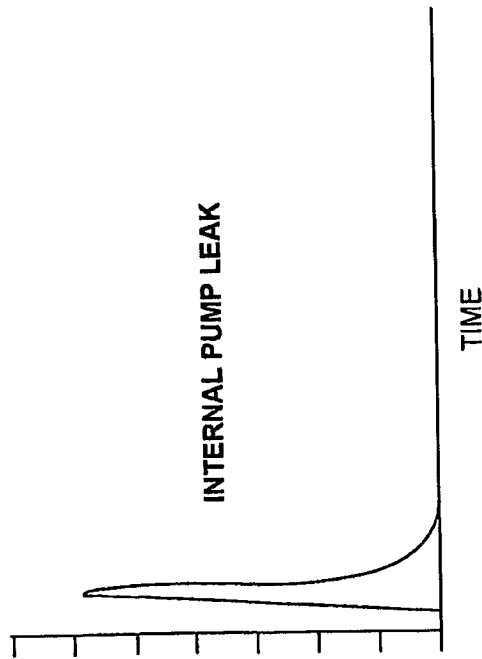

FIG. 11E

+

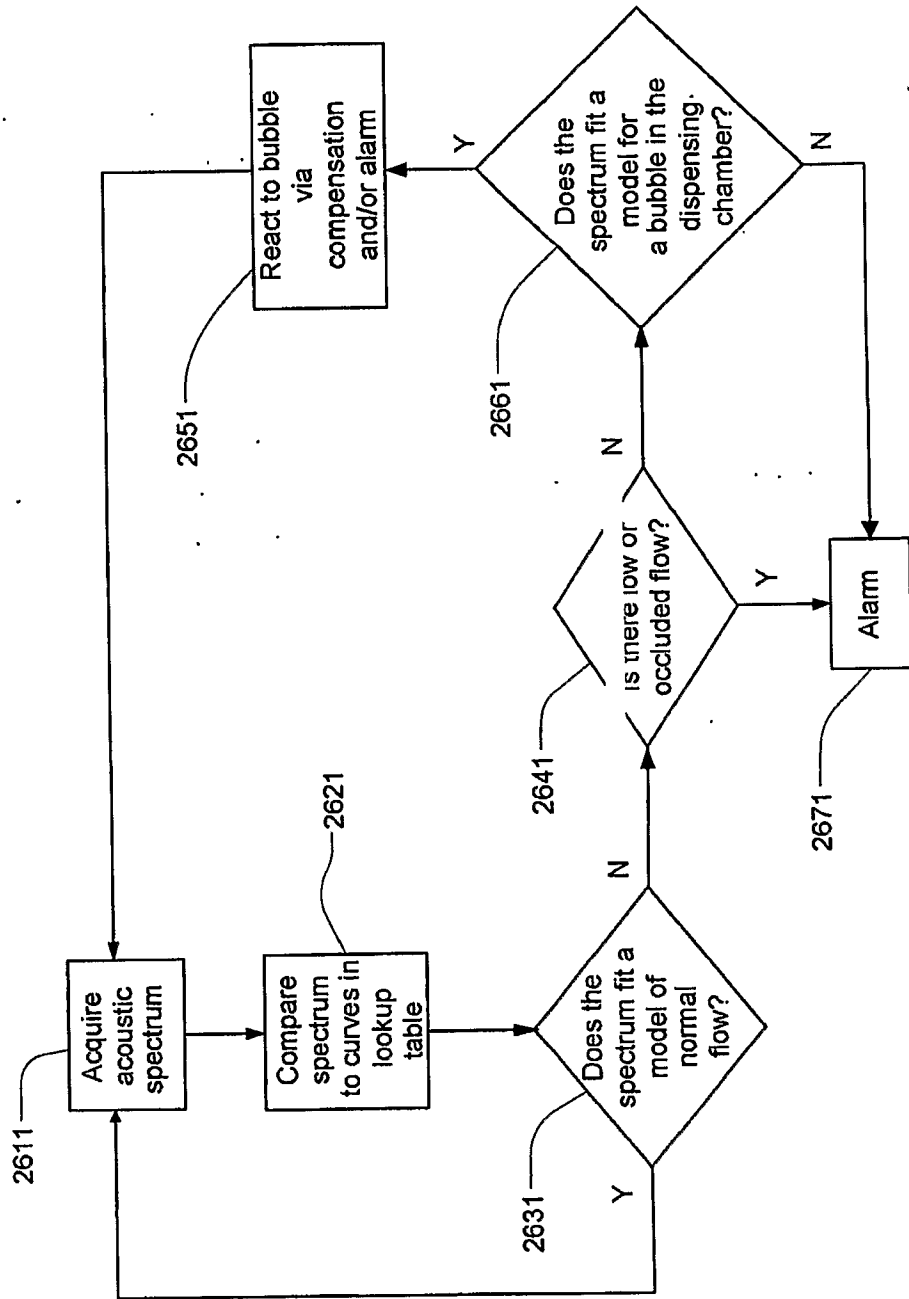

FIG. 12

+

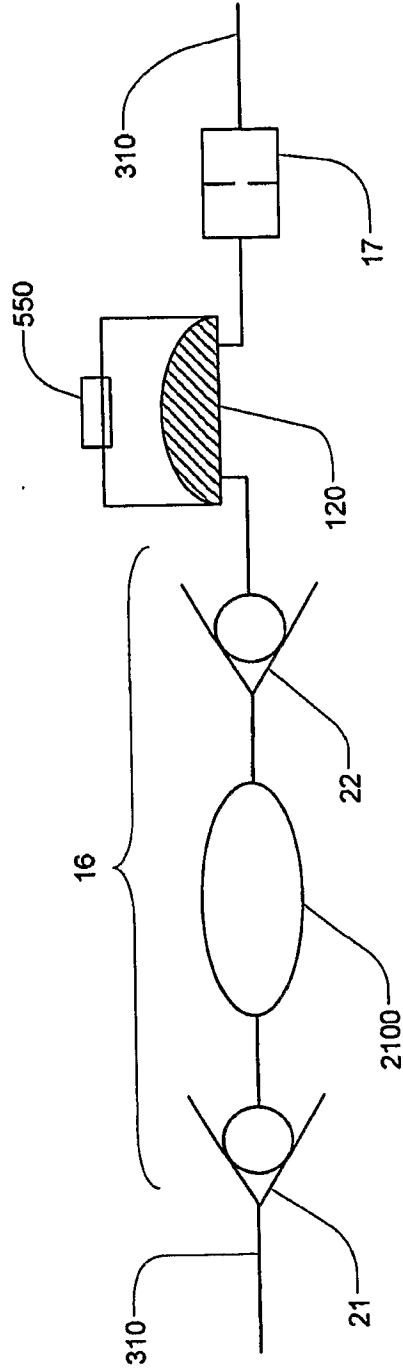

FIG. 13

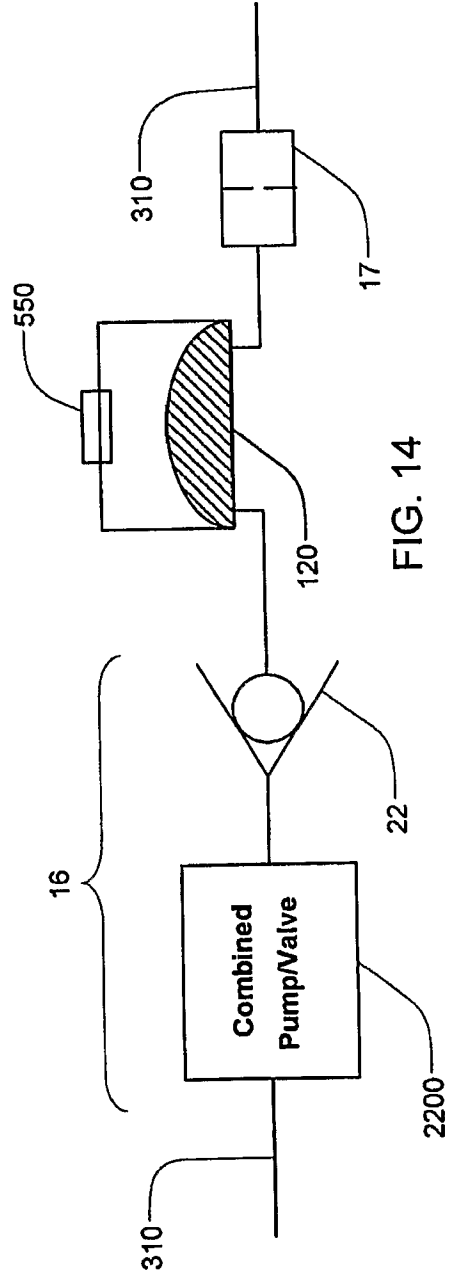

FIG. 14

+

+

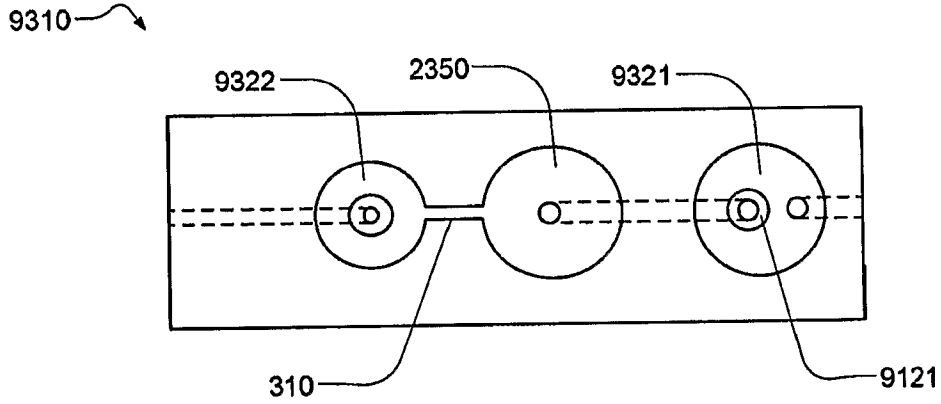

FIG. 15A

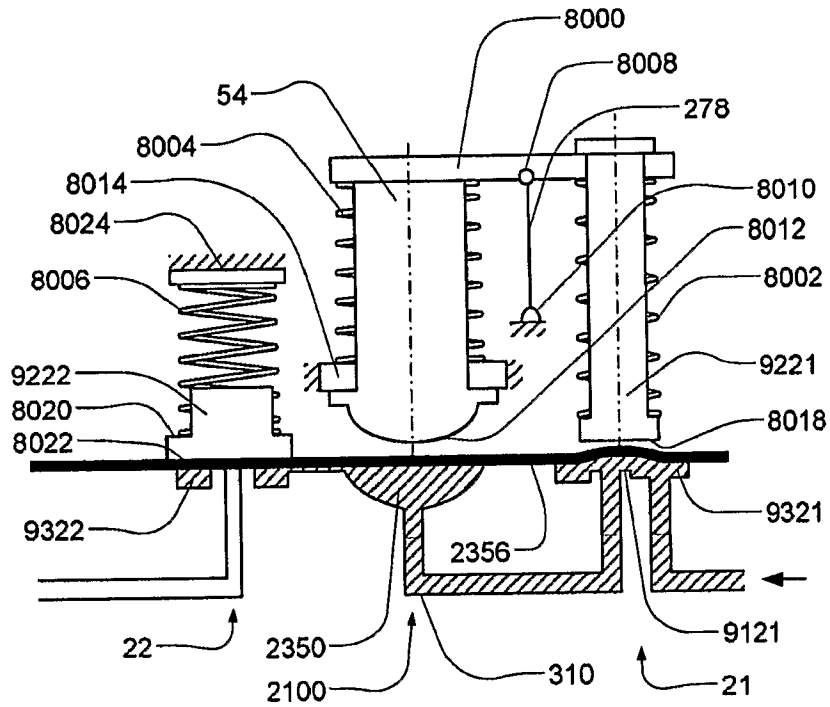

FIG. 15B

+



+

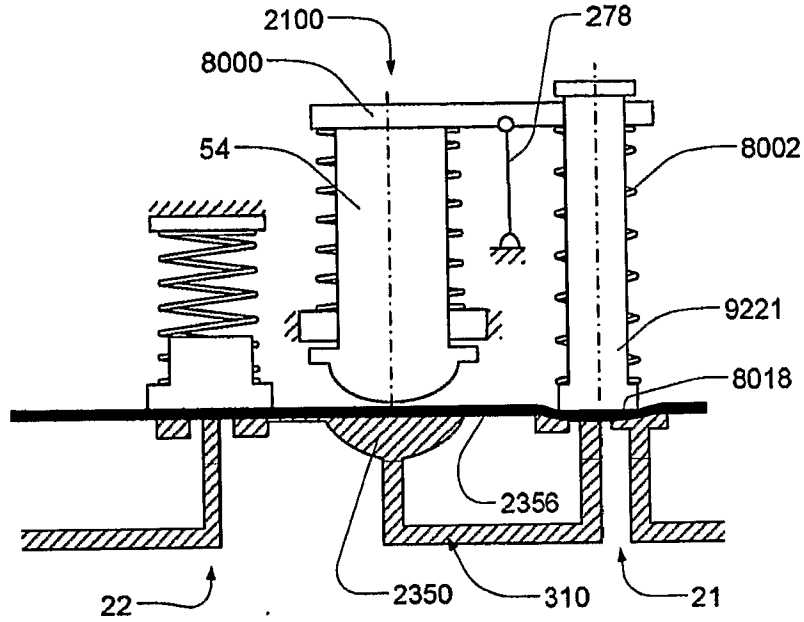

FIG. 15C

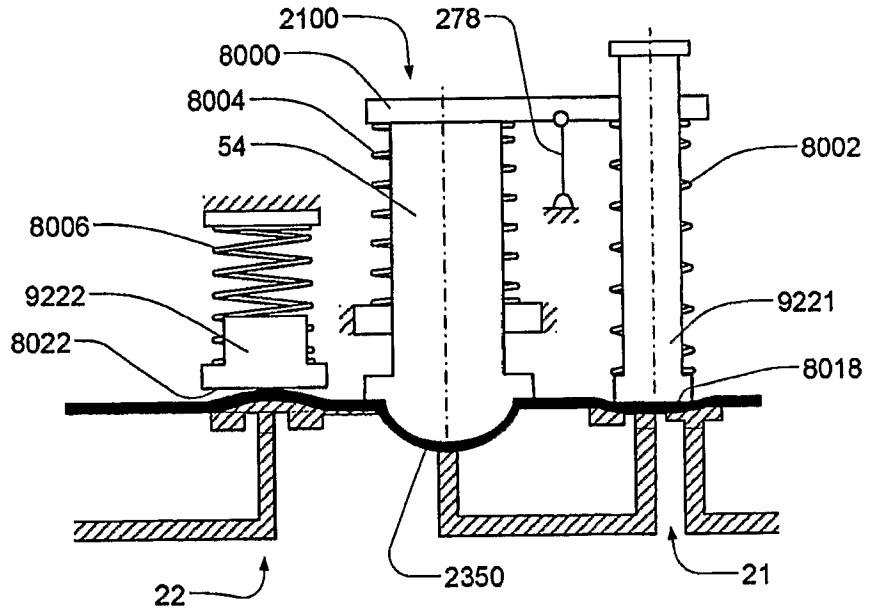

FIG. 15D

+

+

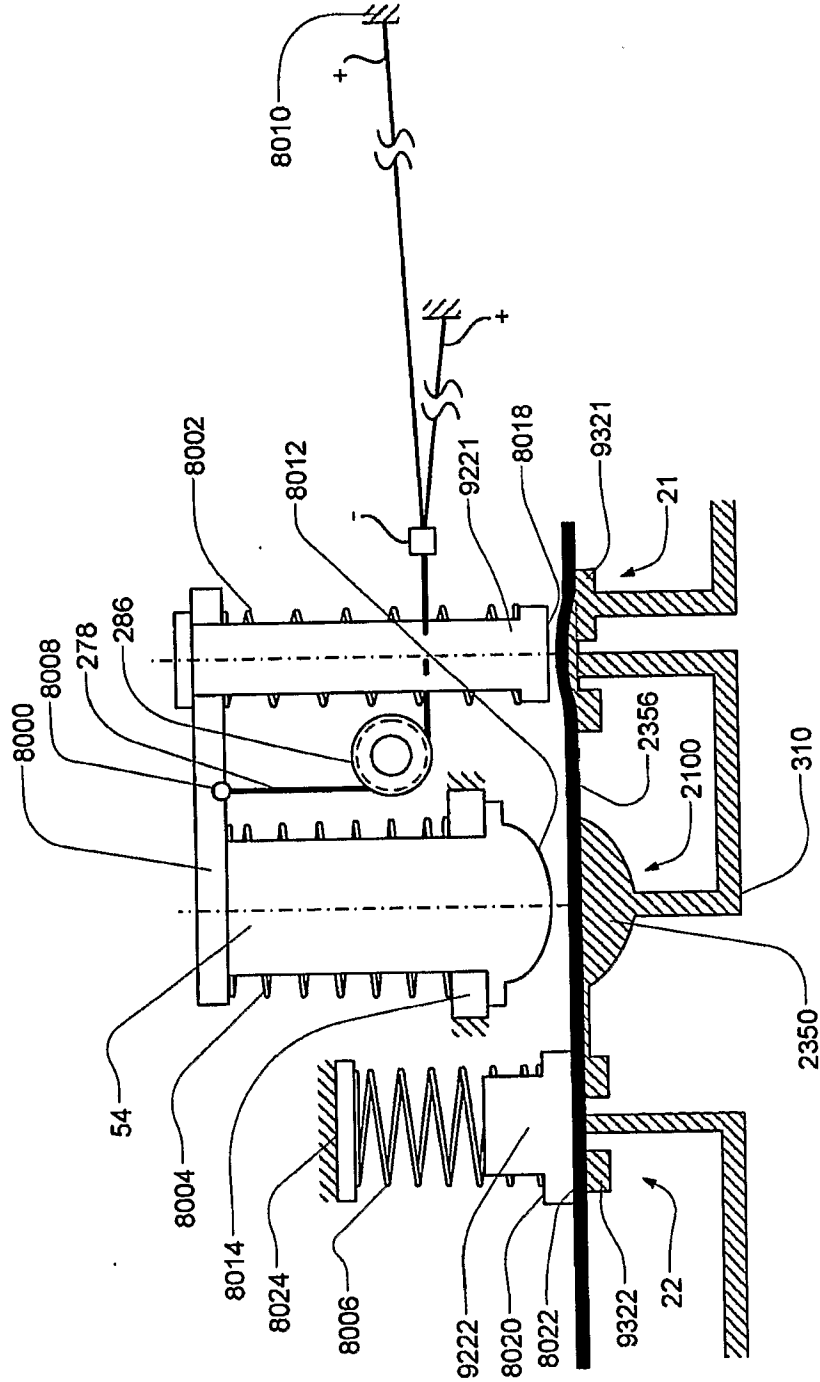

FIG. 16

+

+

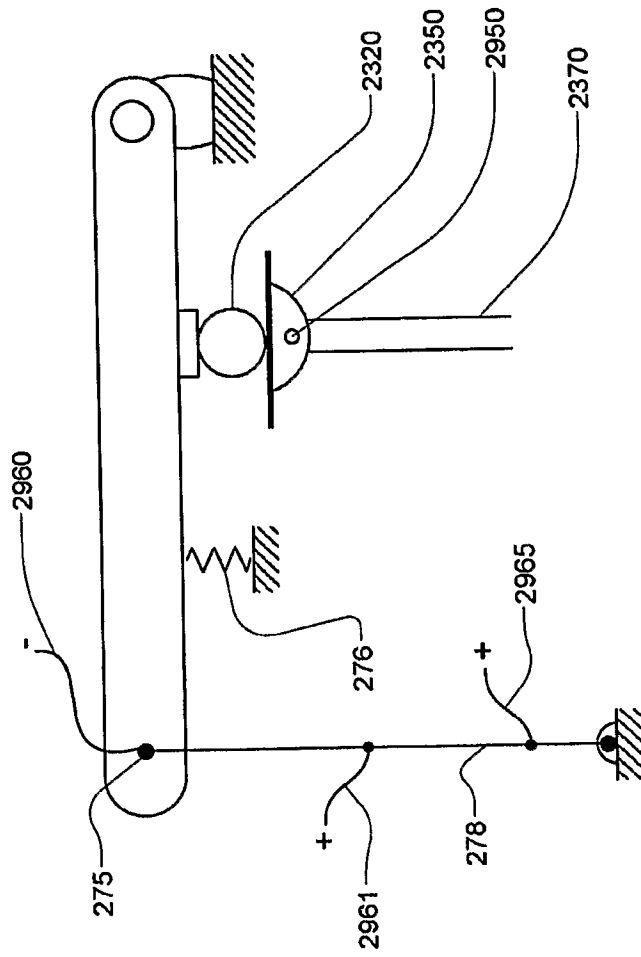

FIG. 17

+

+

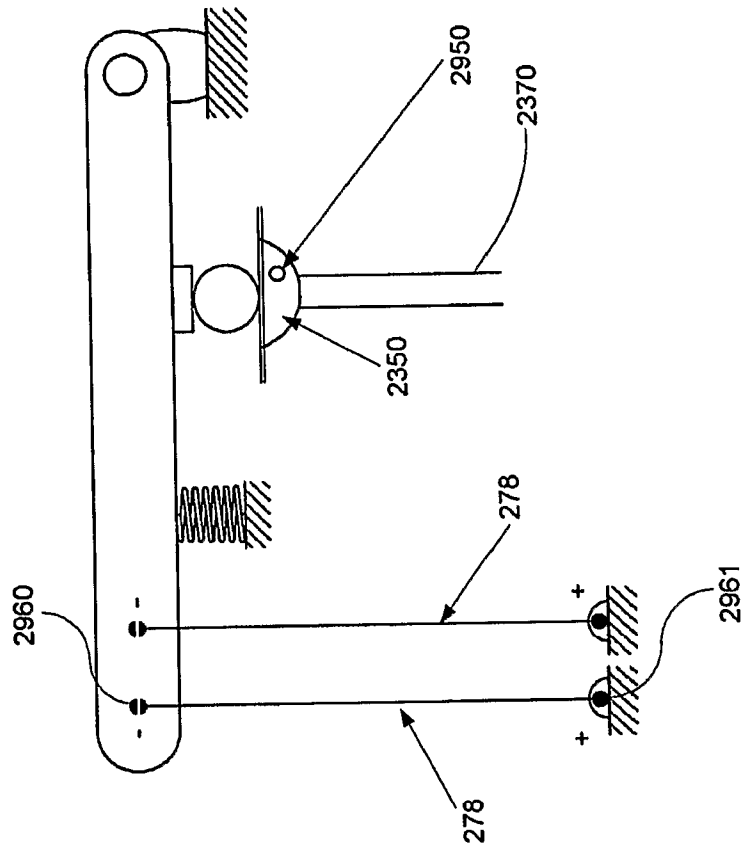

FIG. 18

+

+

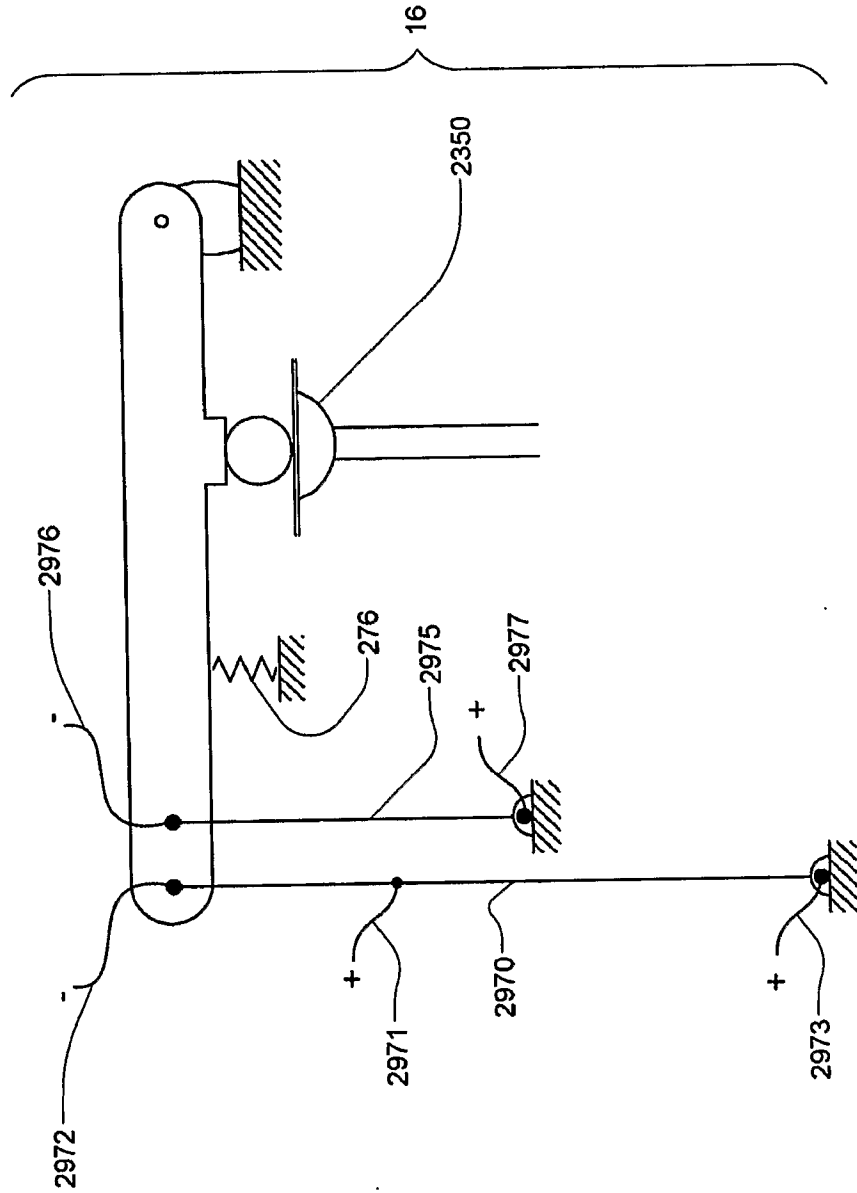

FIG. 19

+

+

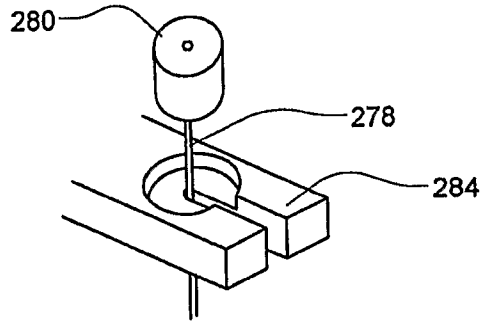

FIG. 20A

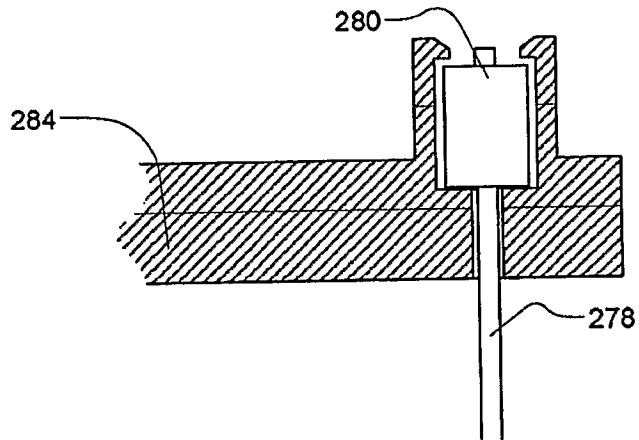

FIG. 20B

+

+

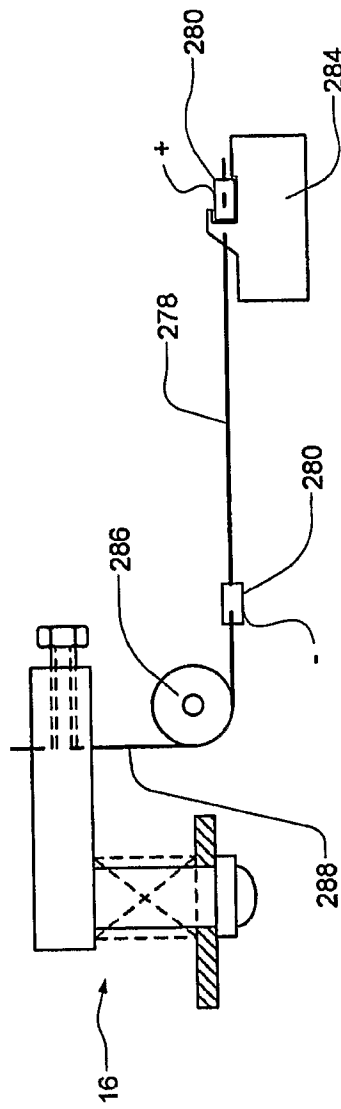

FIG. 21A

+

+

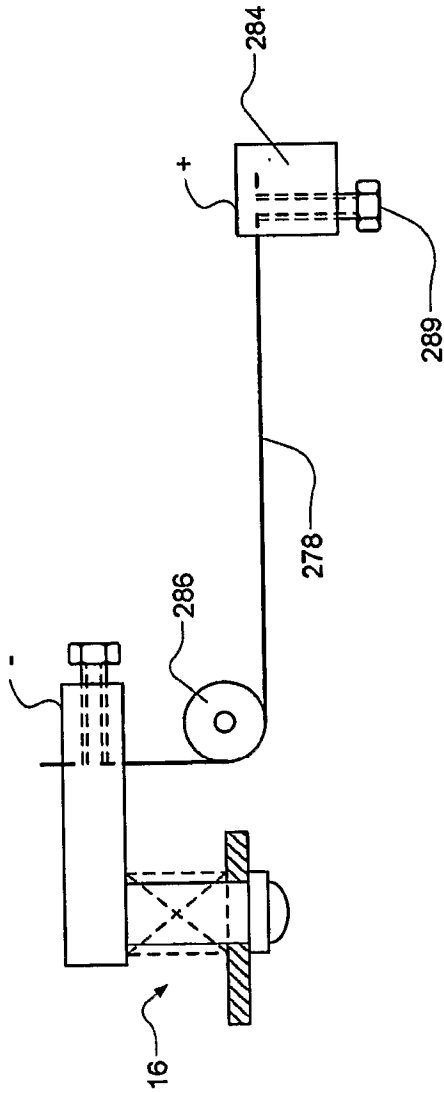

FIG. 21B

+



+

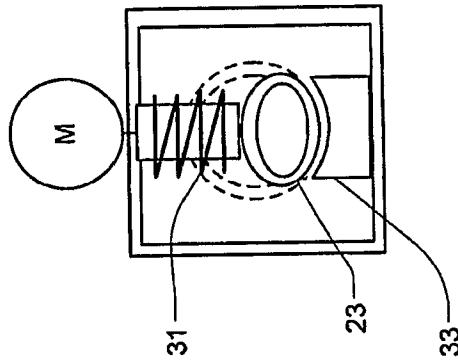

FIG. 23

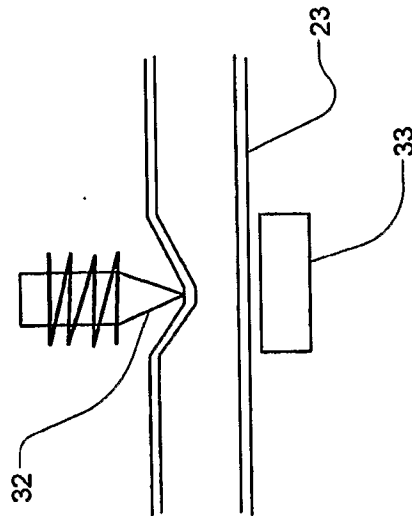

FIG. 22

+

+

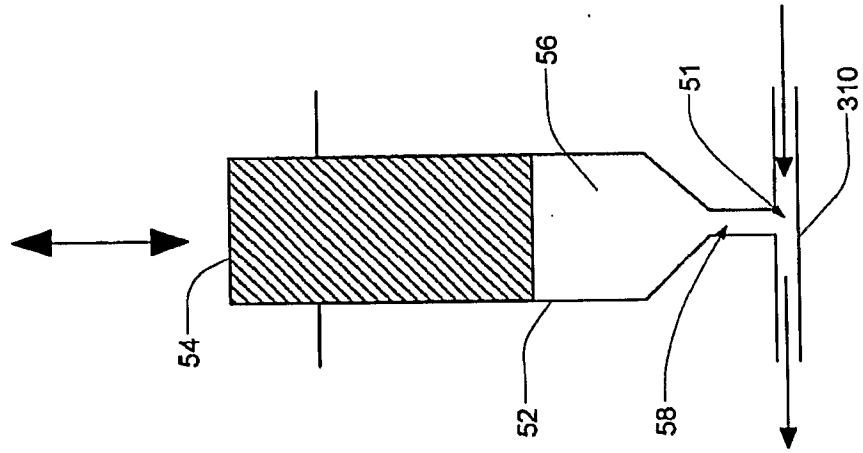

FIG. 25

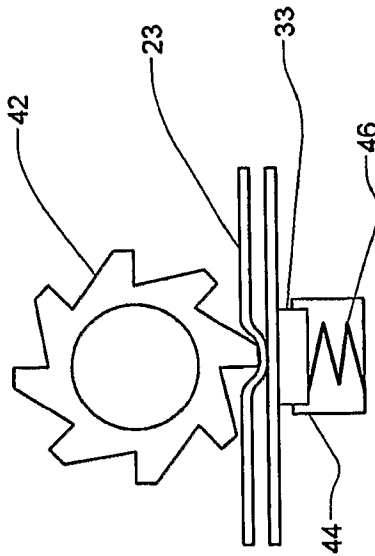

FIG. 24

+

+

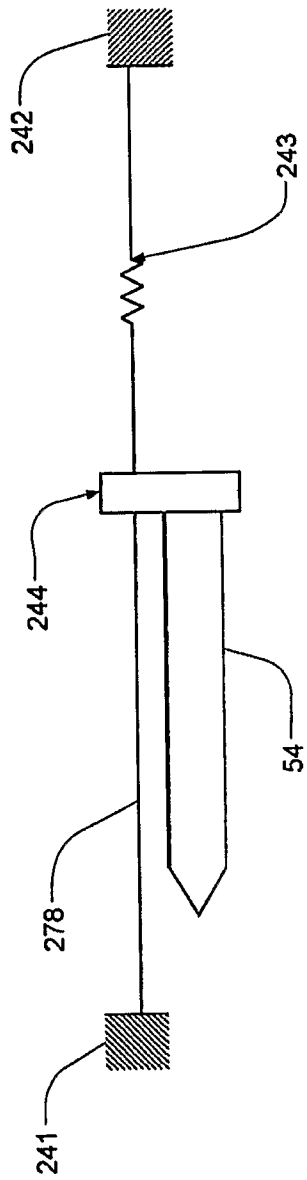

FIG. 26

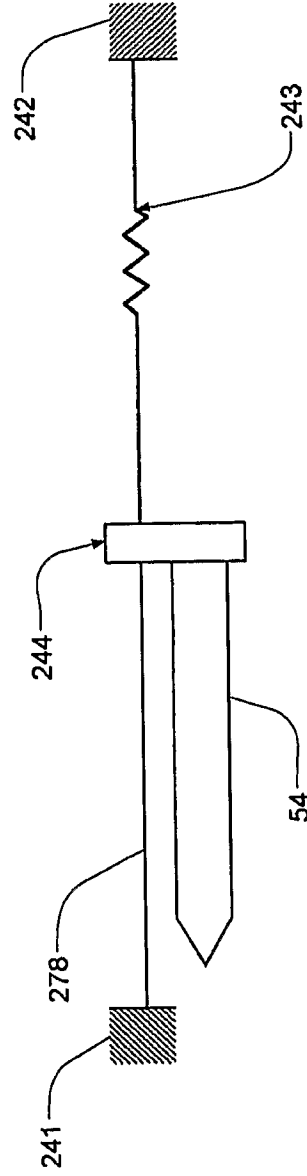

FIG. 27

+

+

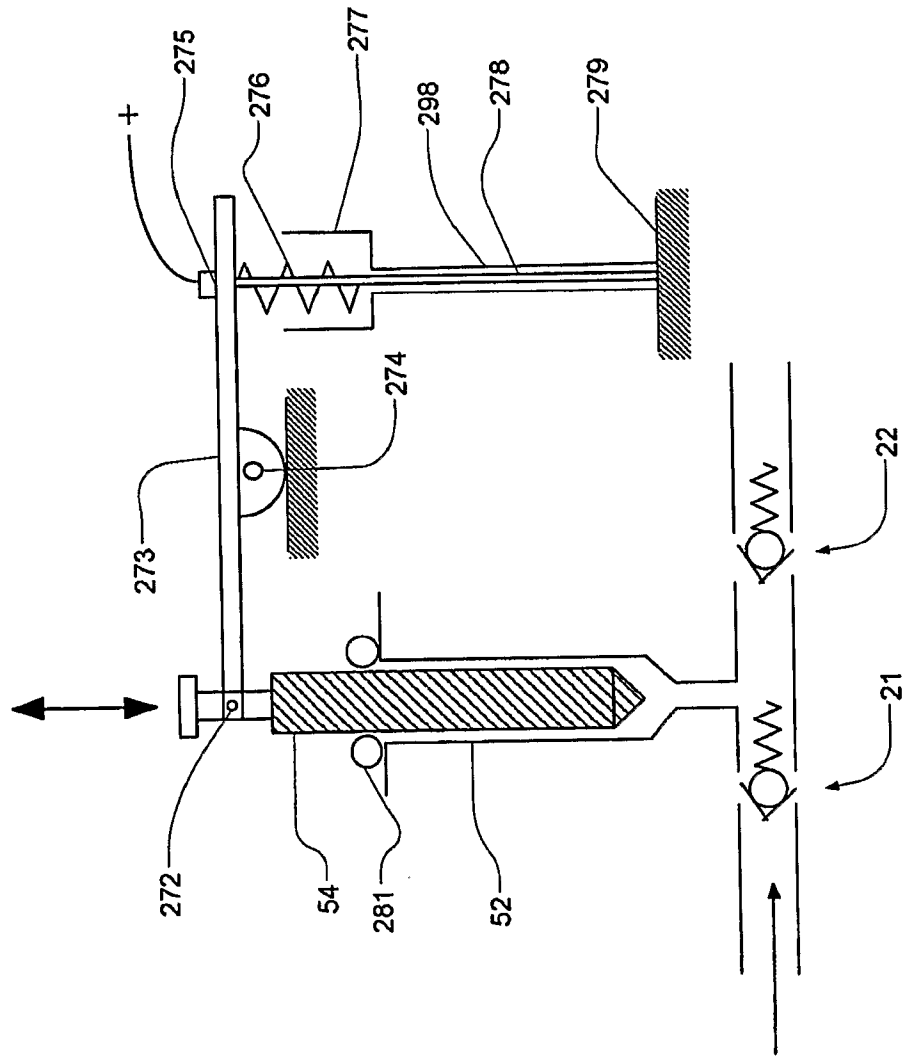

FIG. 28

+

+

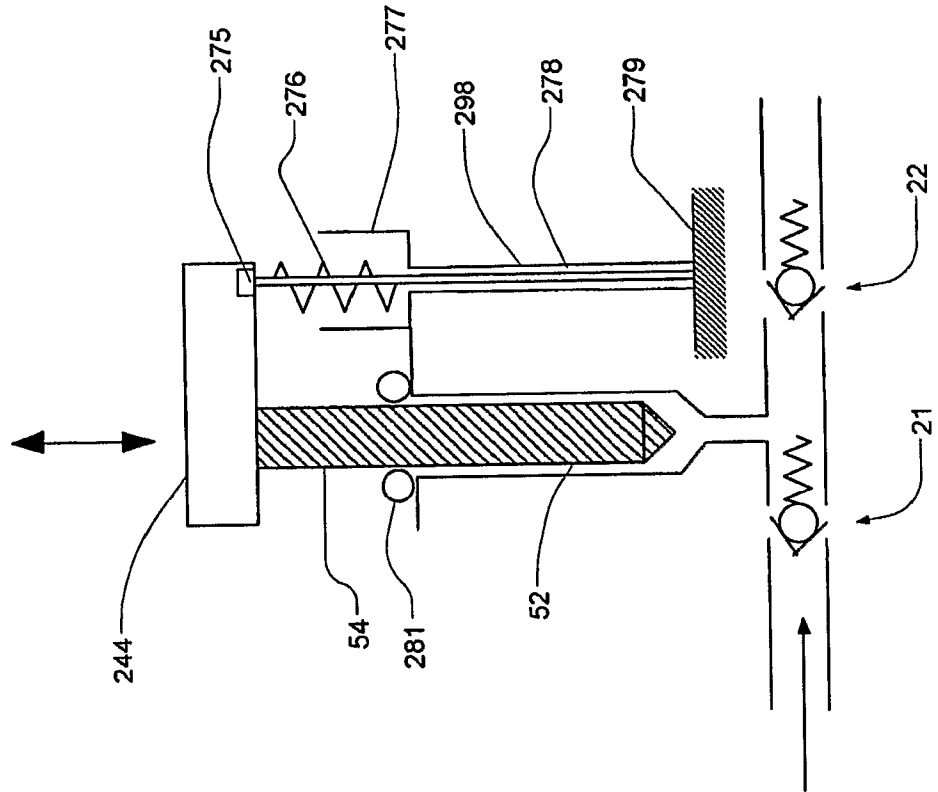

FIG. 29

+

+

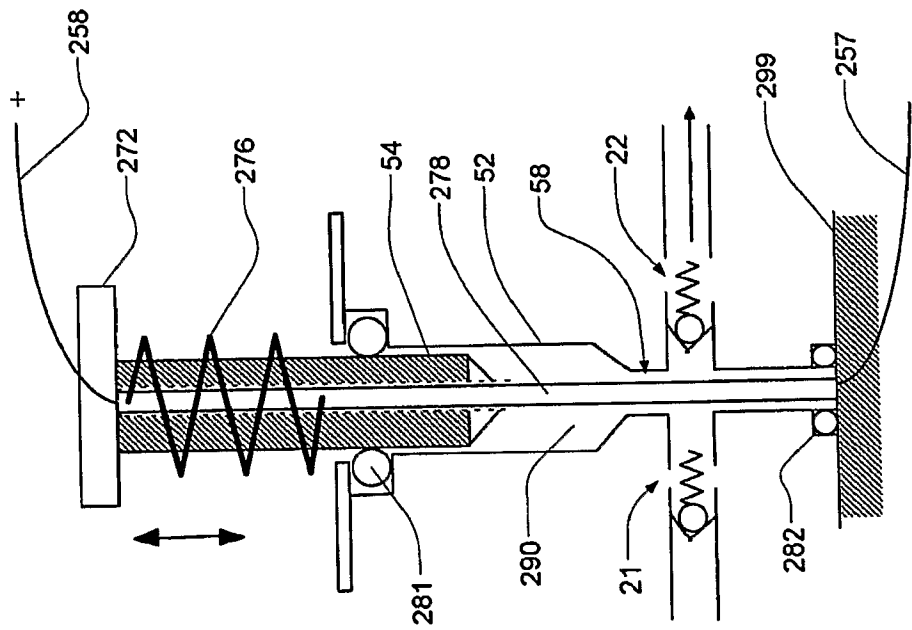

FIG. 30

+

+

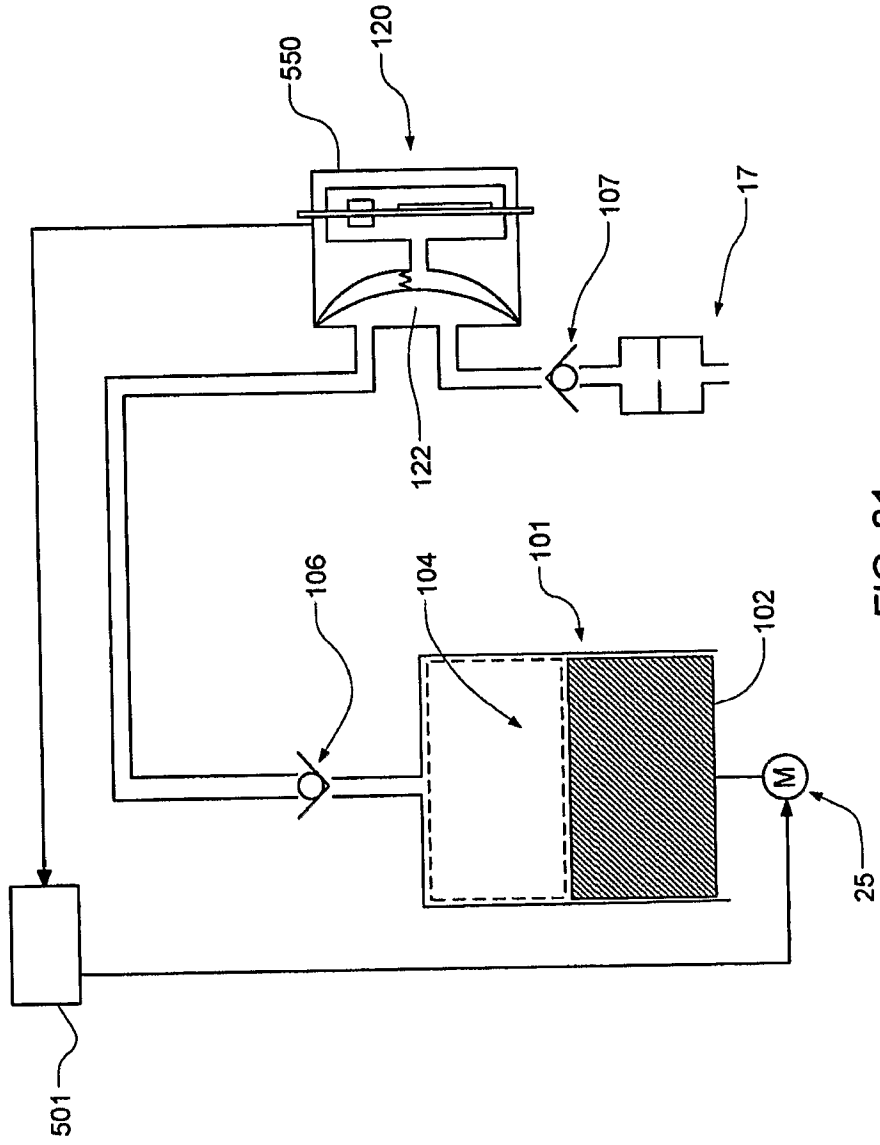

FIG. 31

+

+

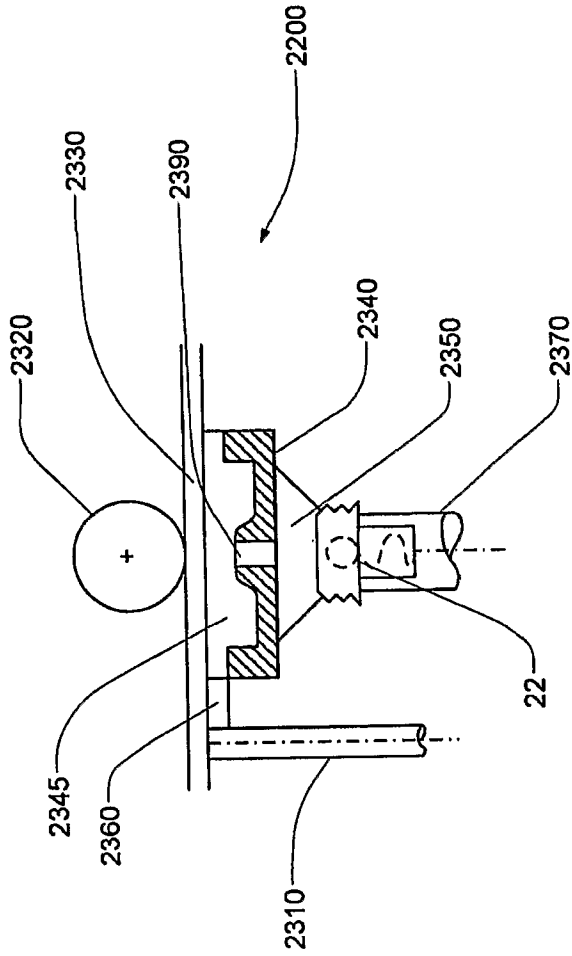

FIG. 32

+



+

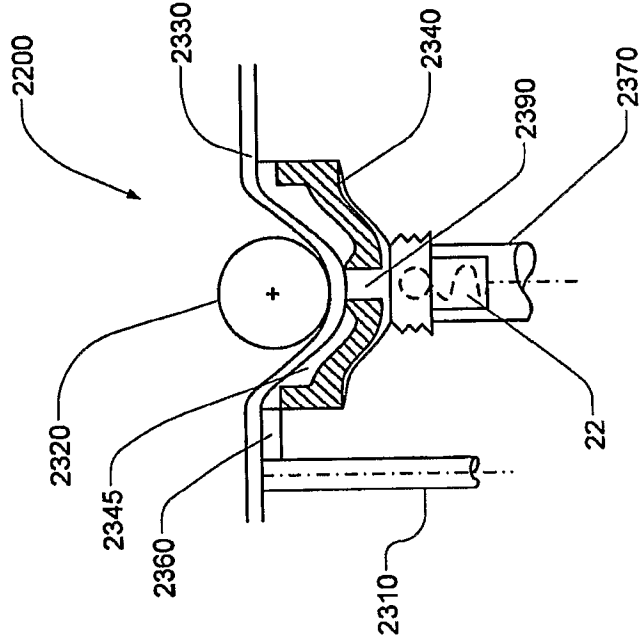

FIG. 34

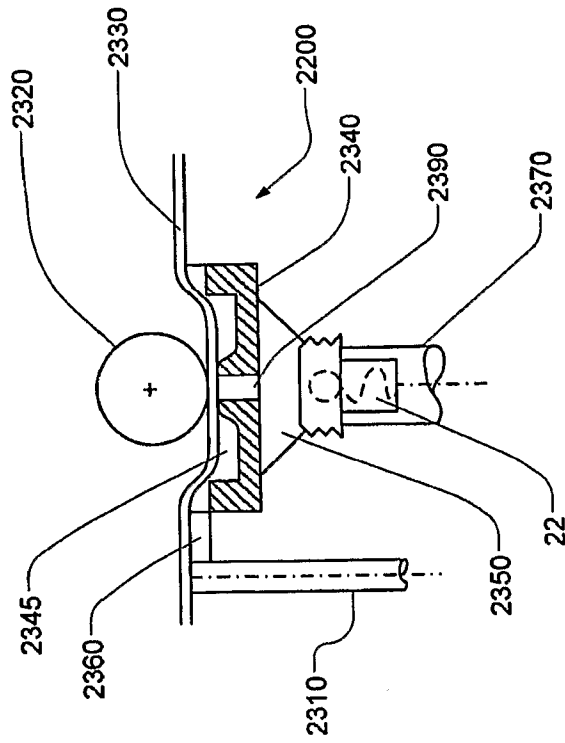

FIG. 33

+

+

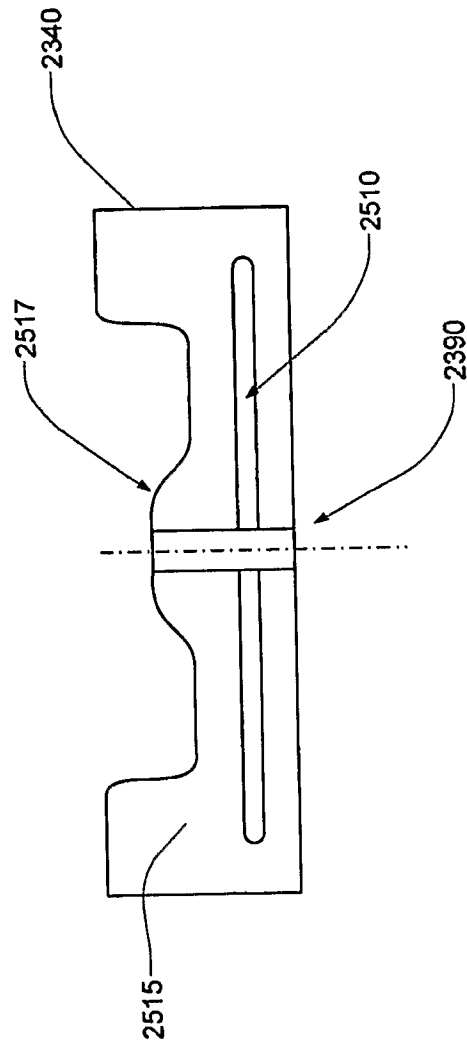

FIG. 35

+

+

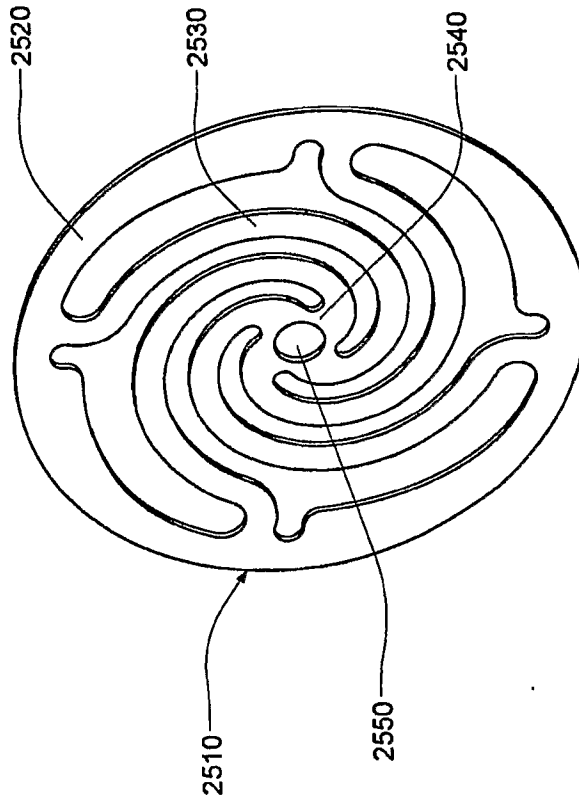

FIG. 36

+

+

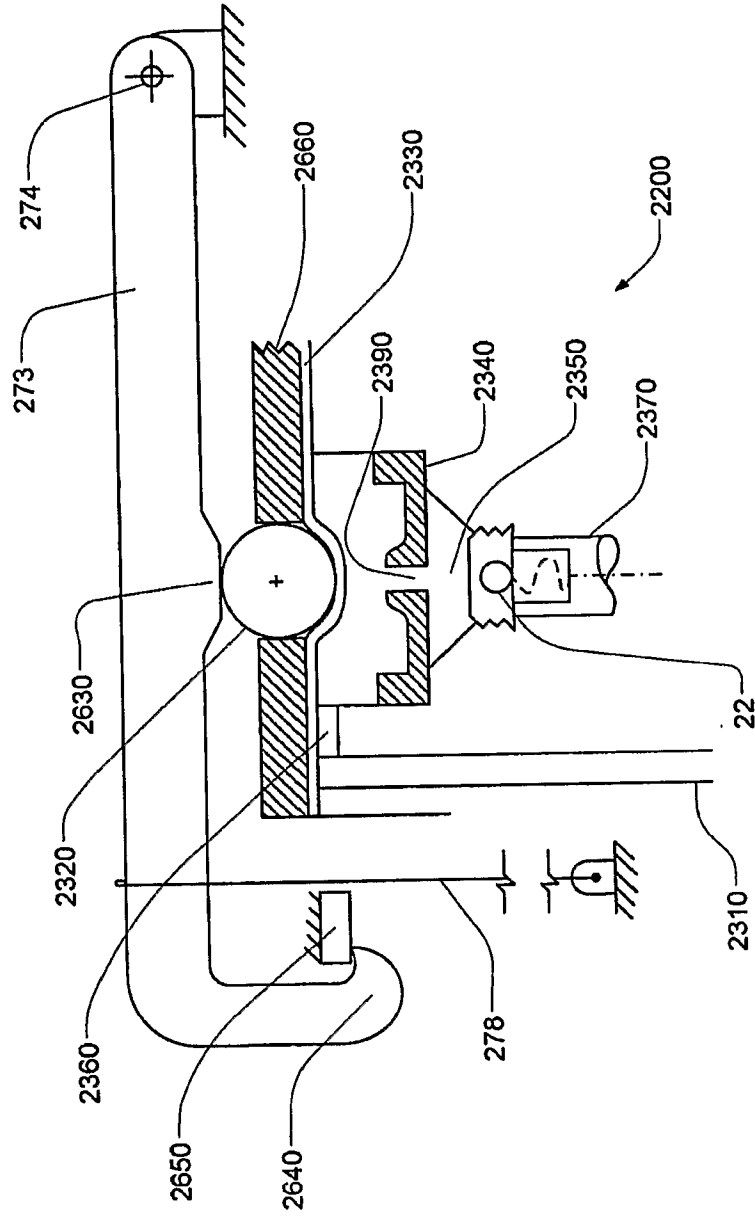

FIG. 37

+

+

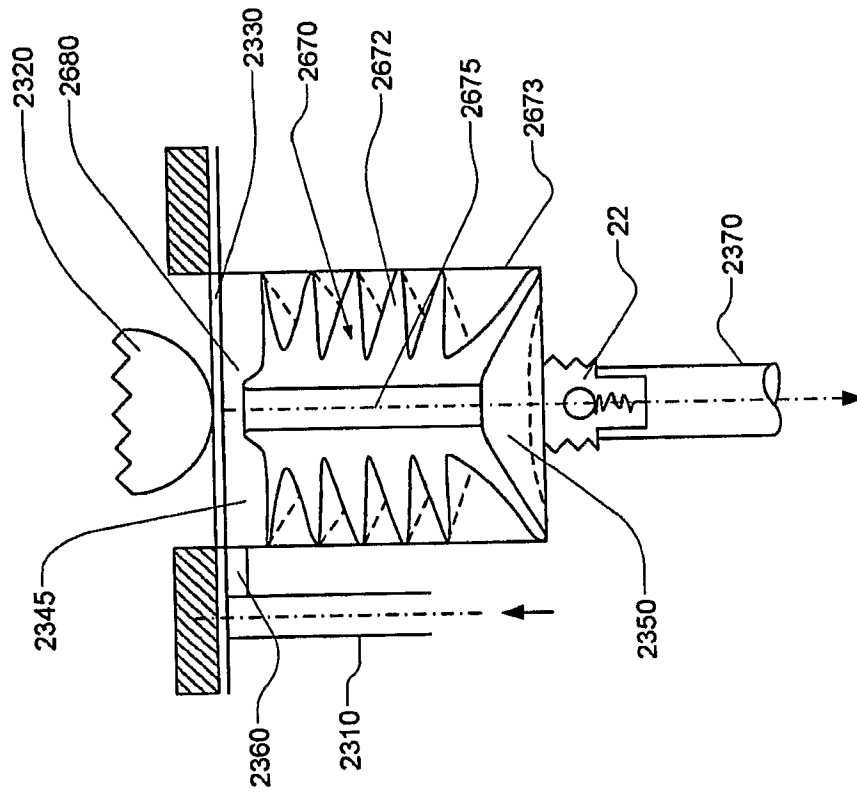

FIG. 38

+

+

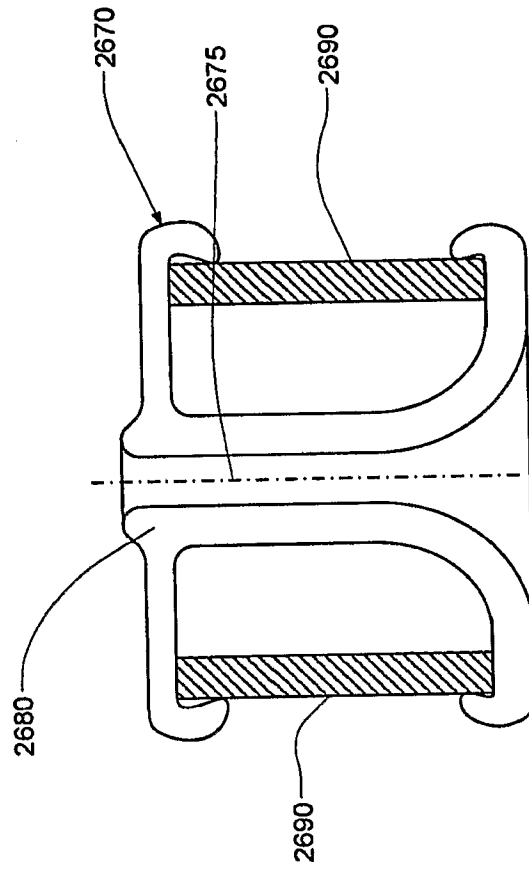

FIG. 39

+

+

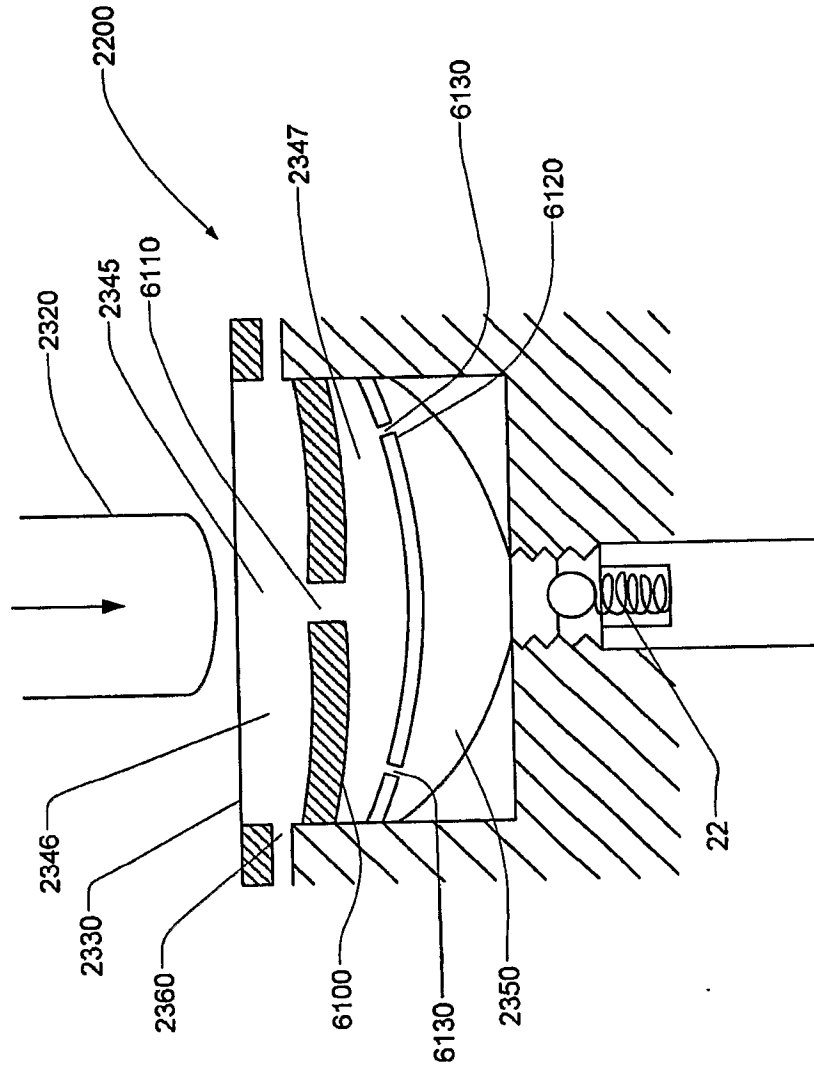

FIG. 40

+

+

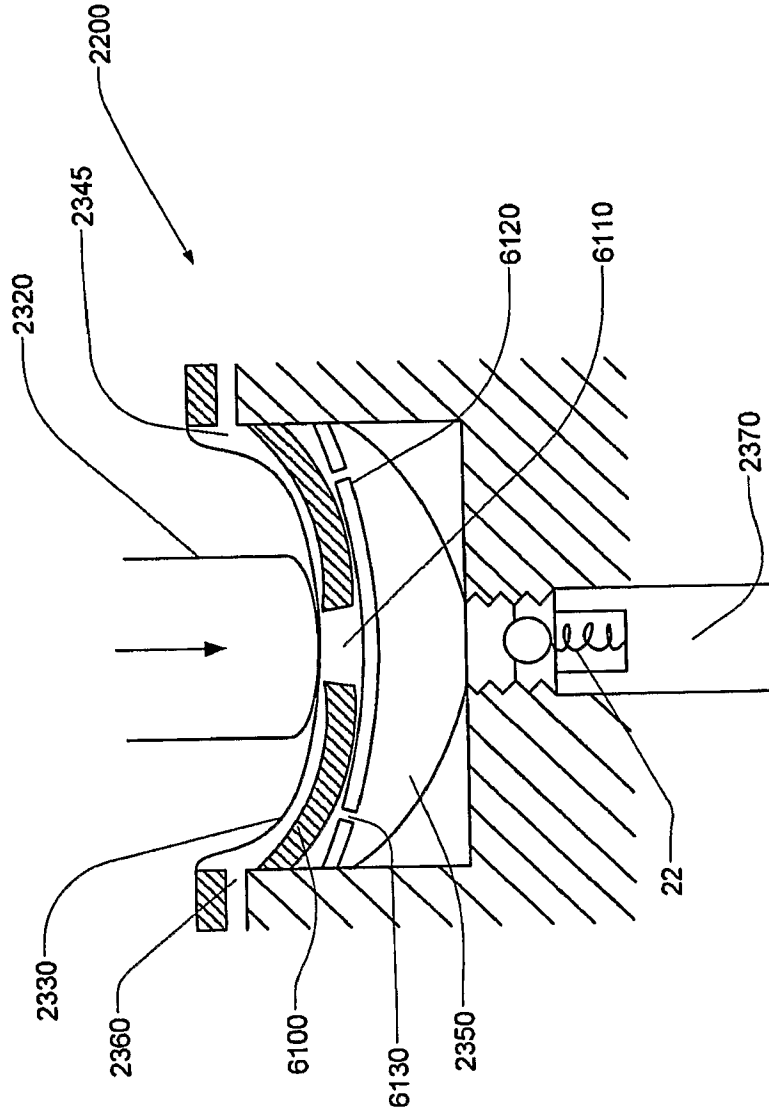

FIG. 41

+



+

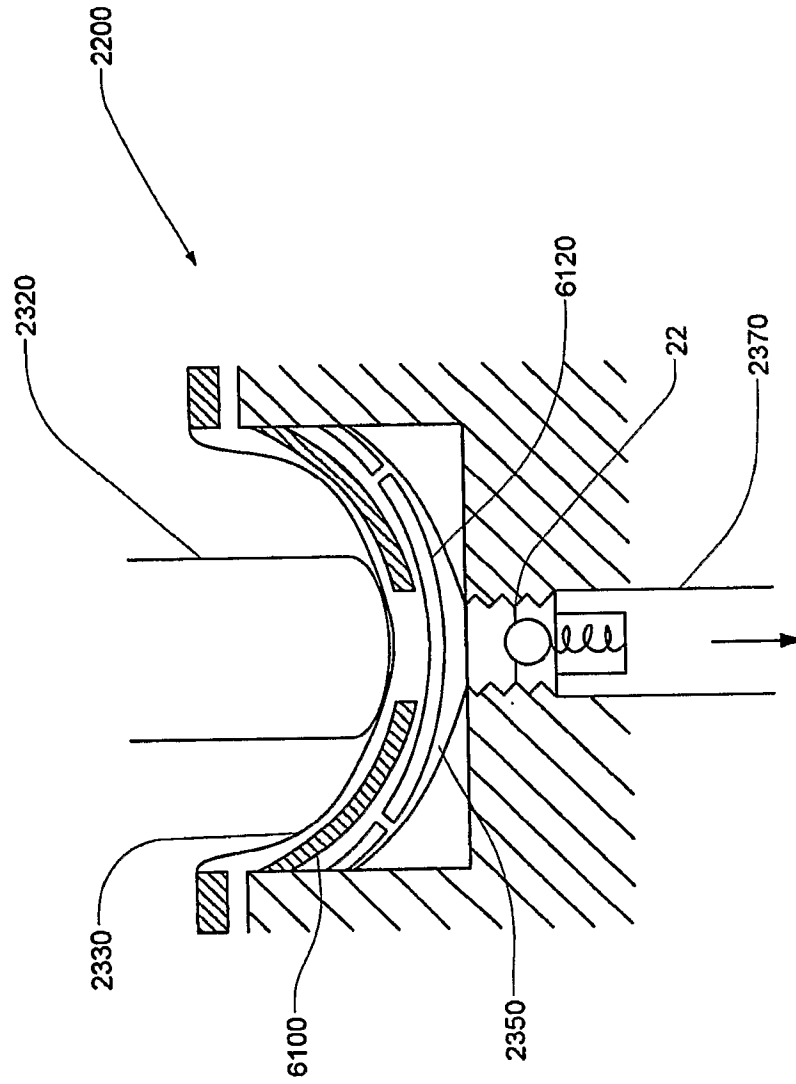

FIG. 42

+

+

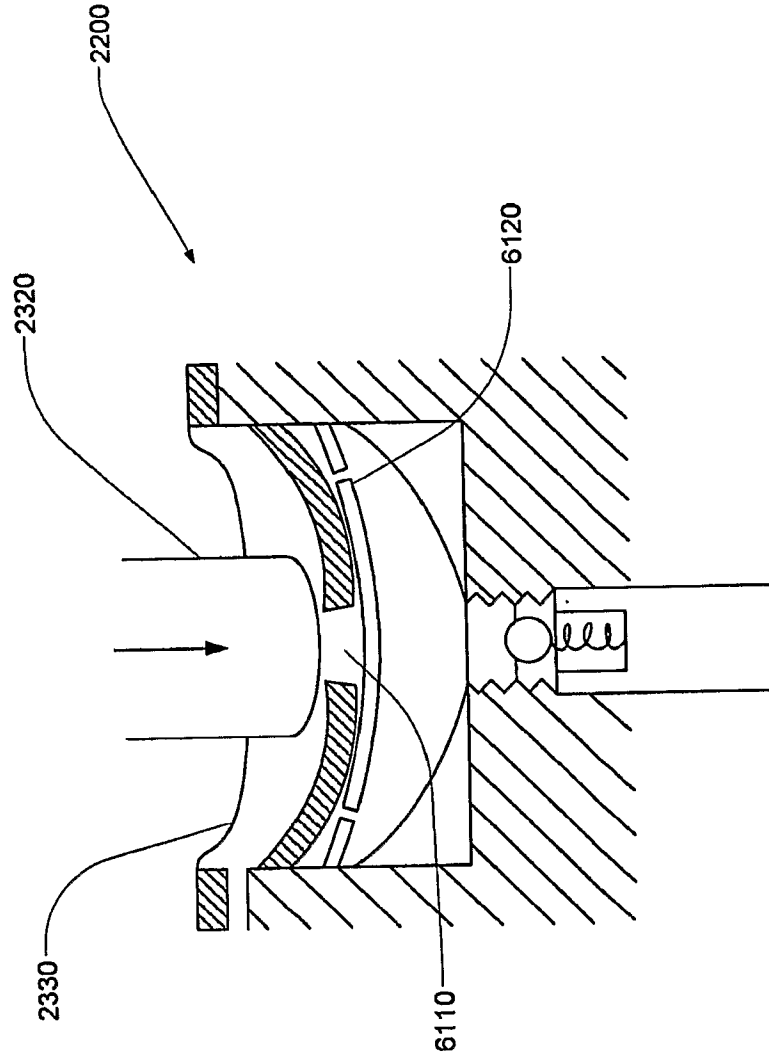

FIG. 43

+

+

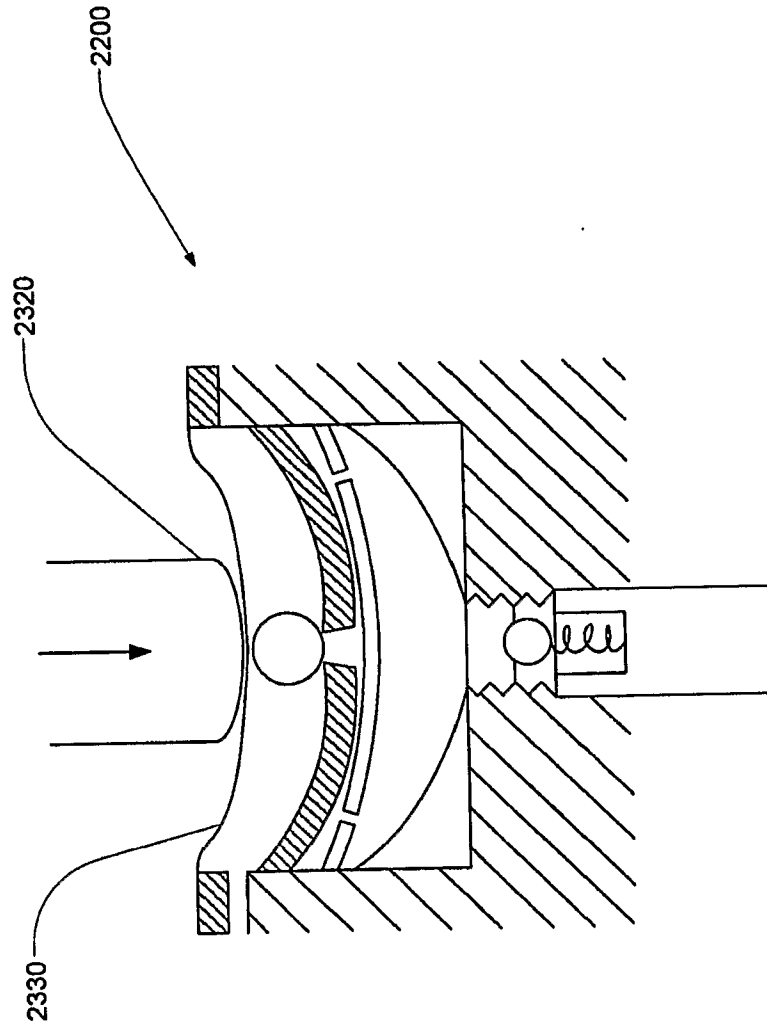

FIG. 44

+

+

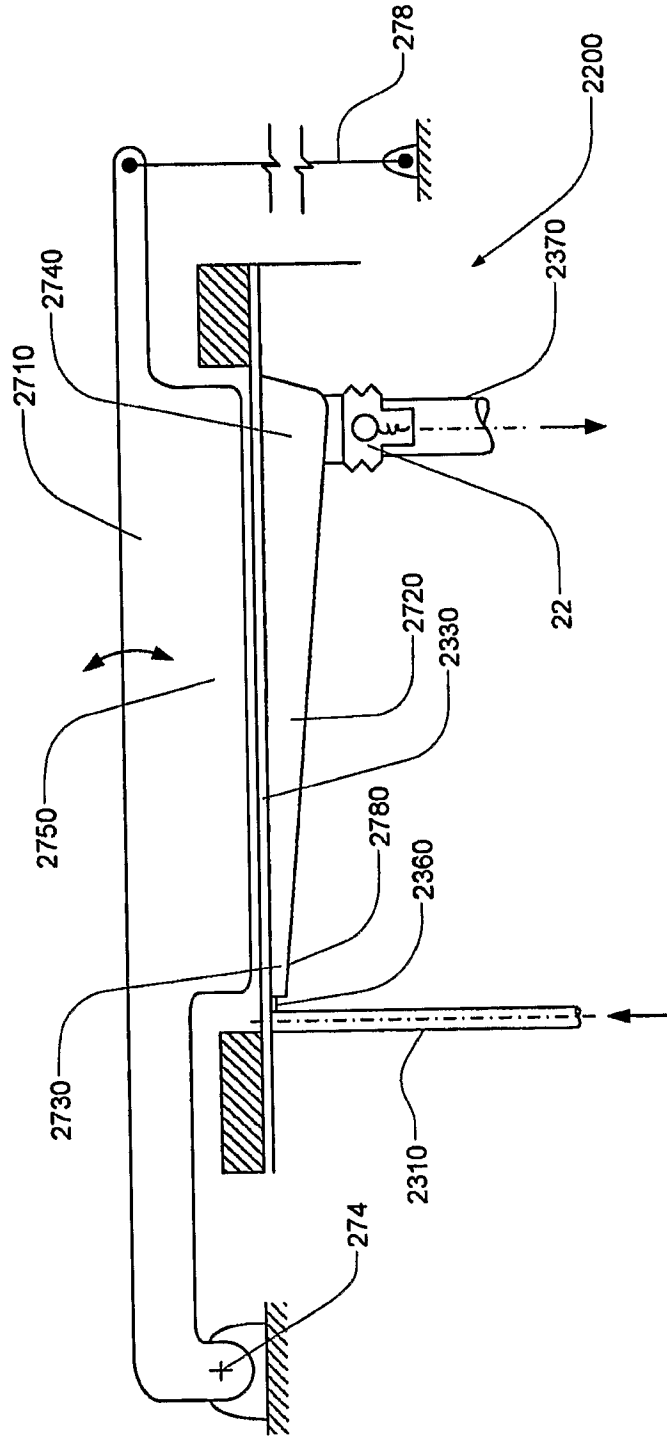

FIG. 45

+

+

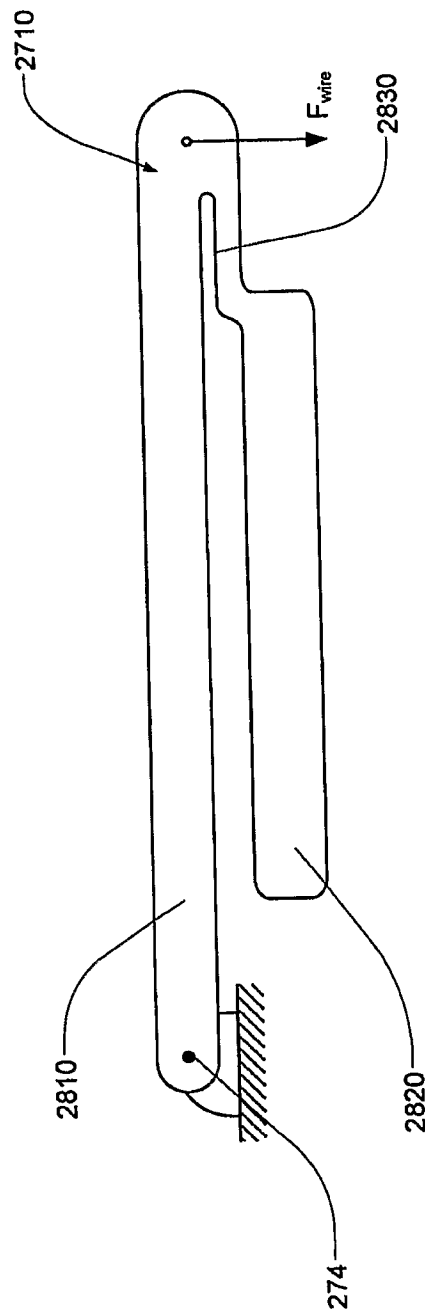

FIG. 46

+

+

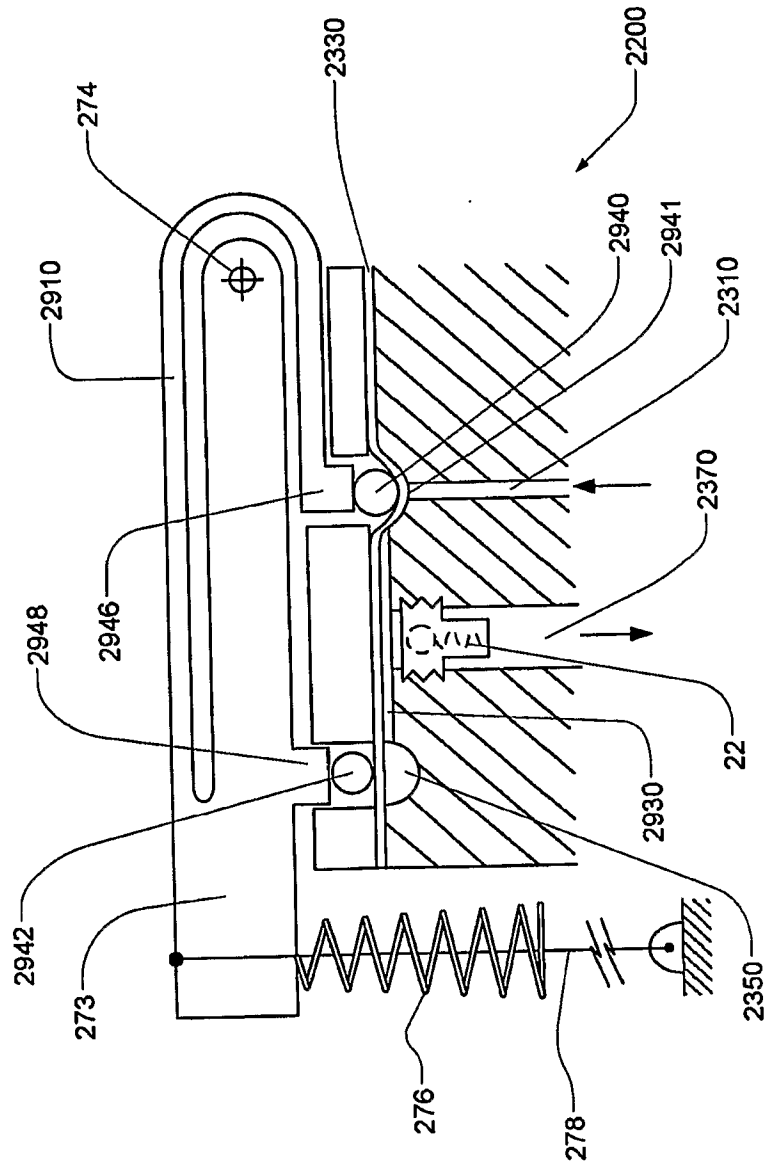

FIG. 47

+

+

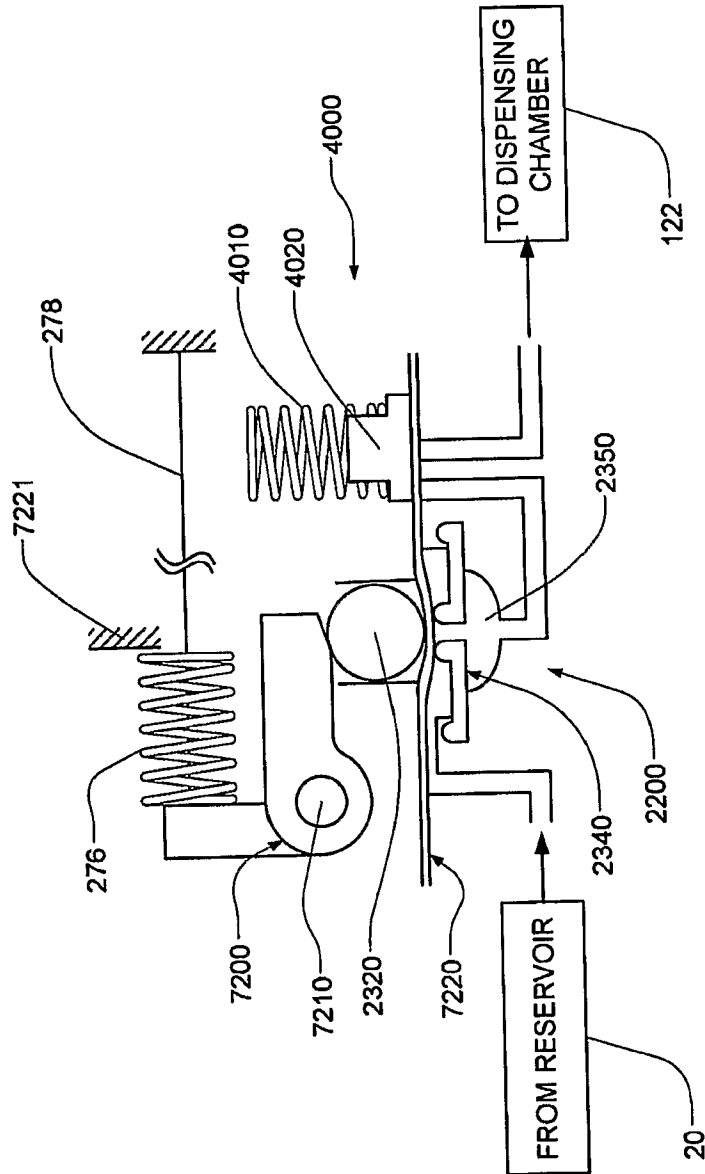

FIG. 48

+

+

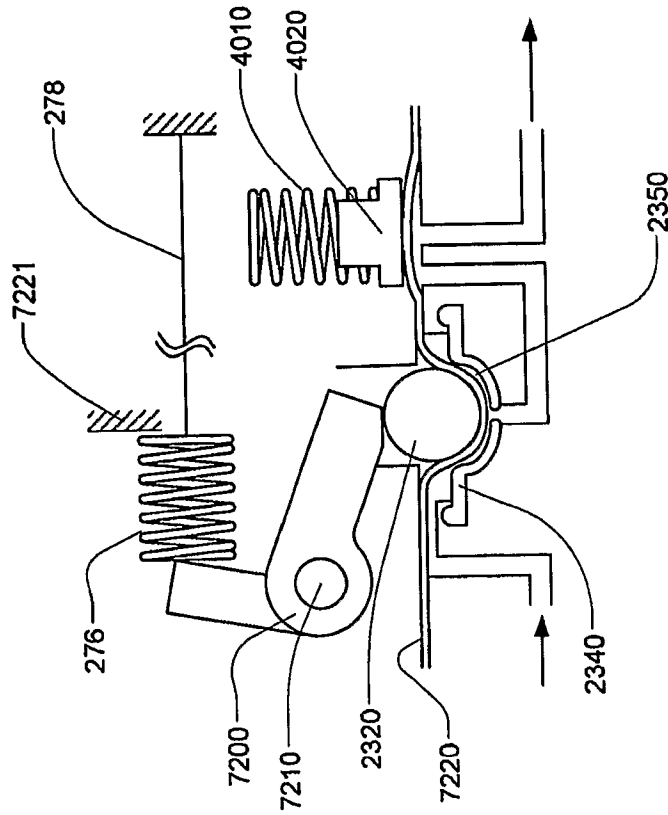

FIG. 49

+



+

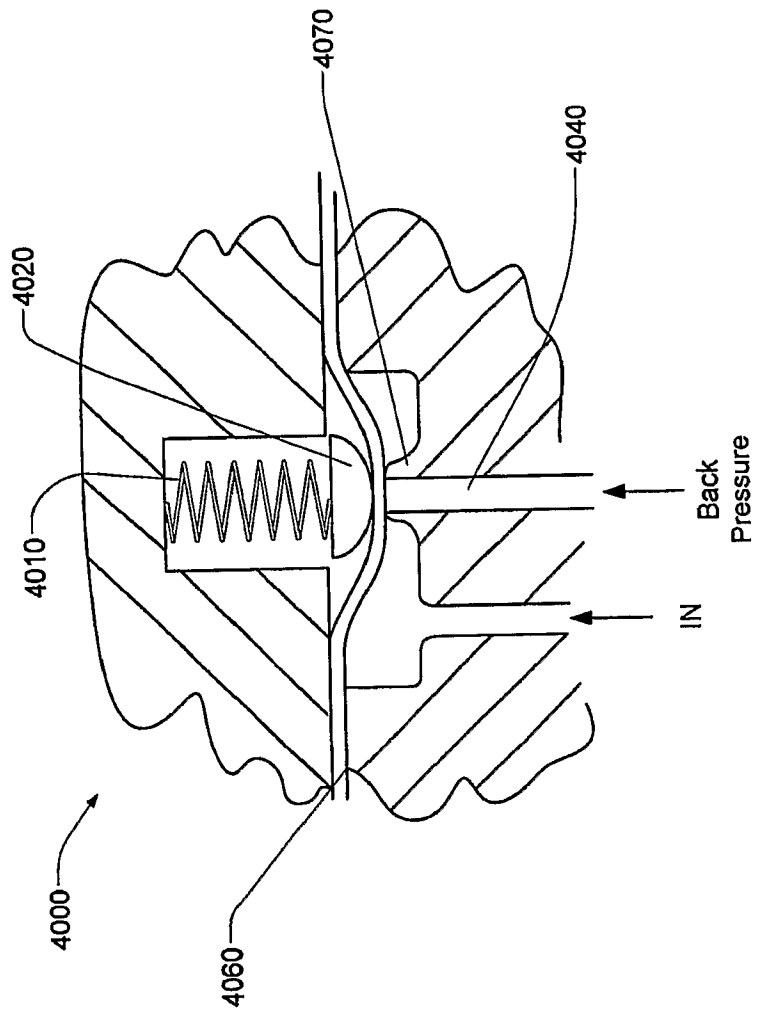

FIG. 50

+

+

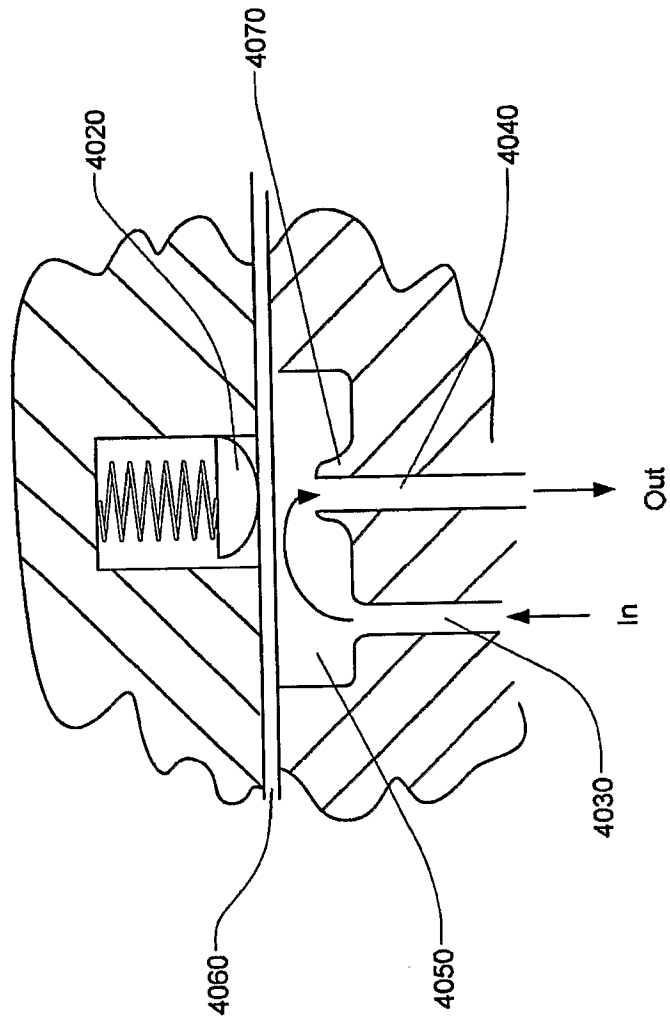

FIG. 51

+

+

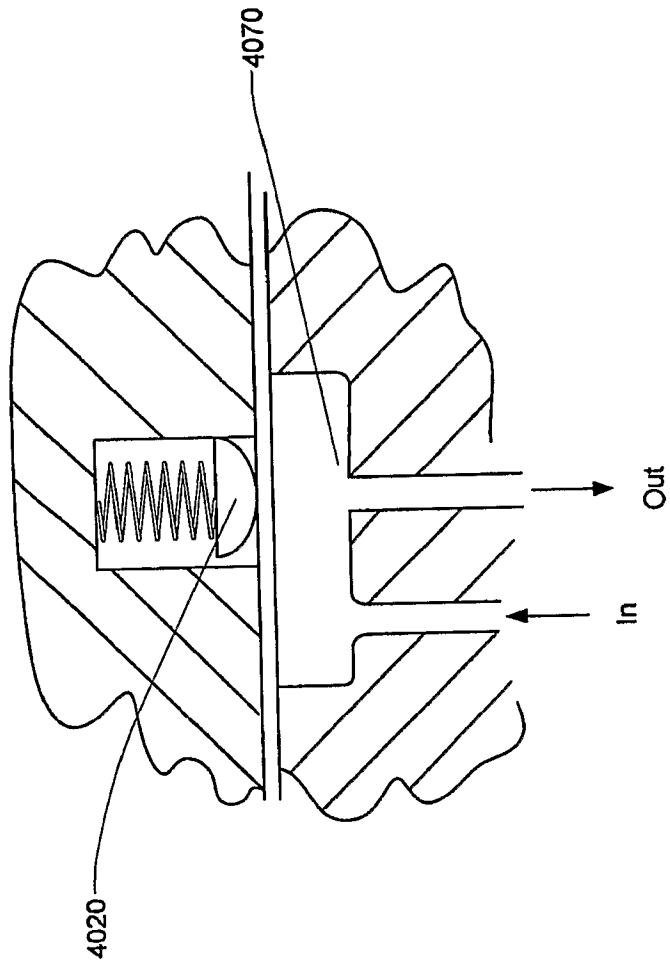

FIG. 52

+

+

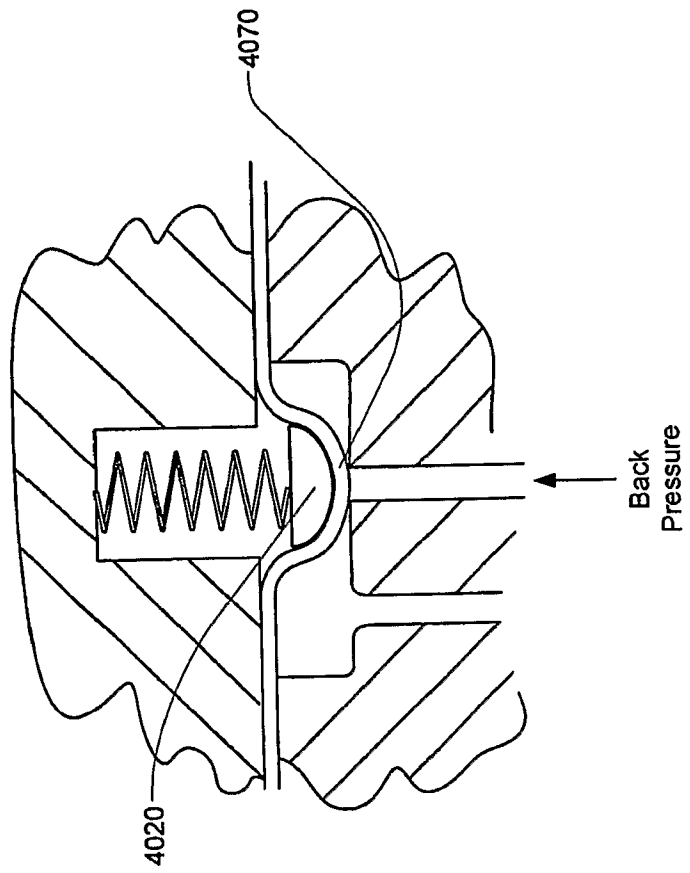

FIG. 53

+

+

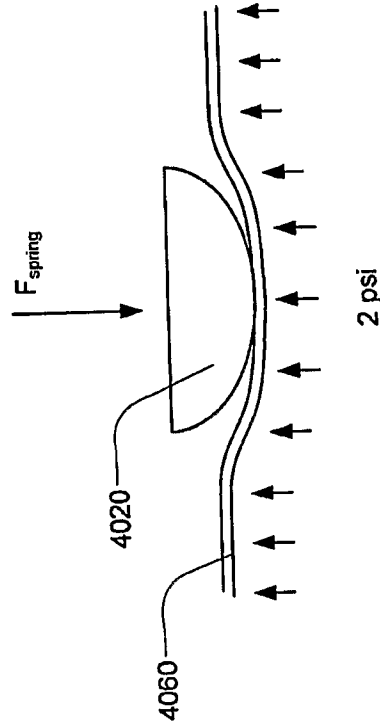

FIG. 55

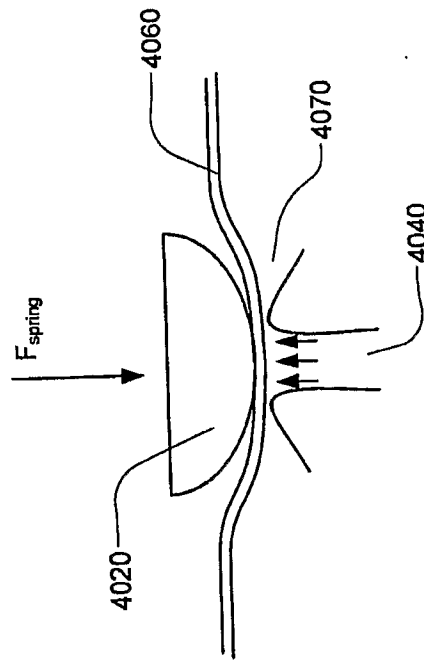

FIG. 54

+

+

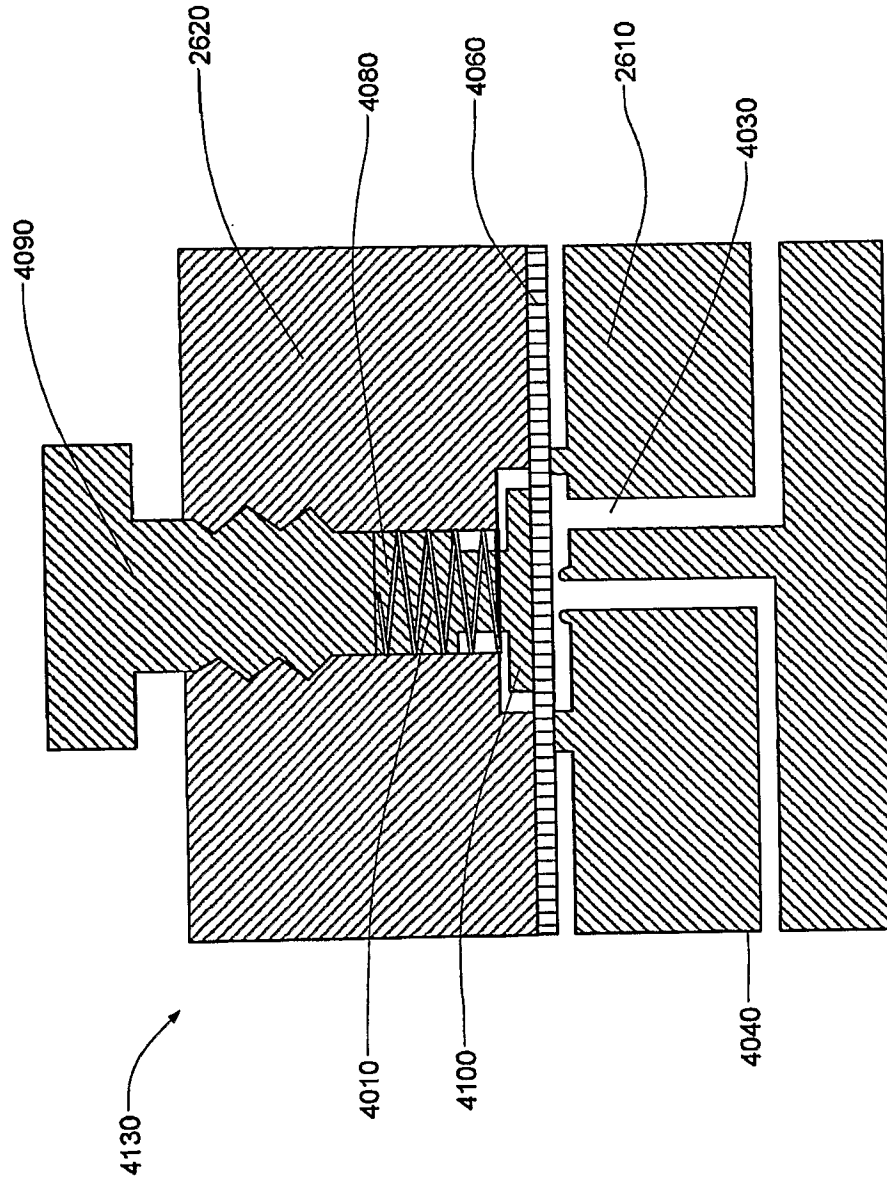

FIG. 56

+

+

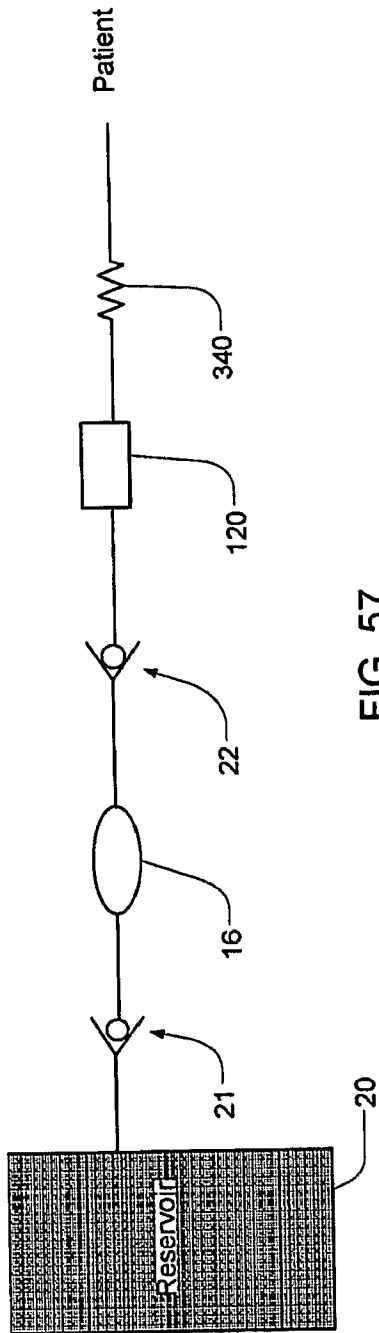

FIG. 57

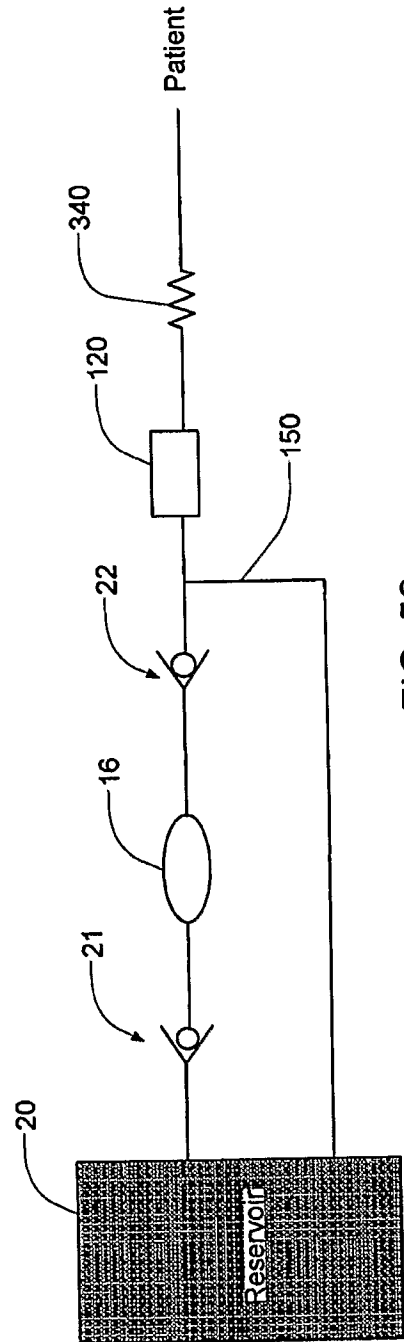

FIG. 58

+

+

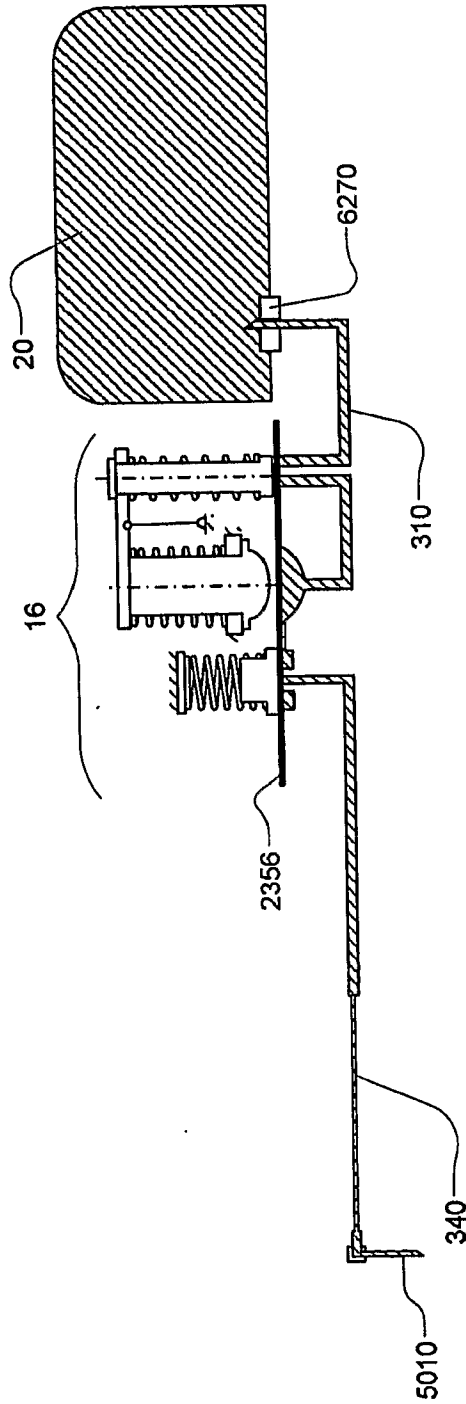

FIG. 59A

+



+

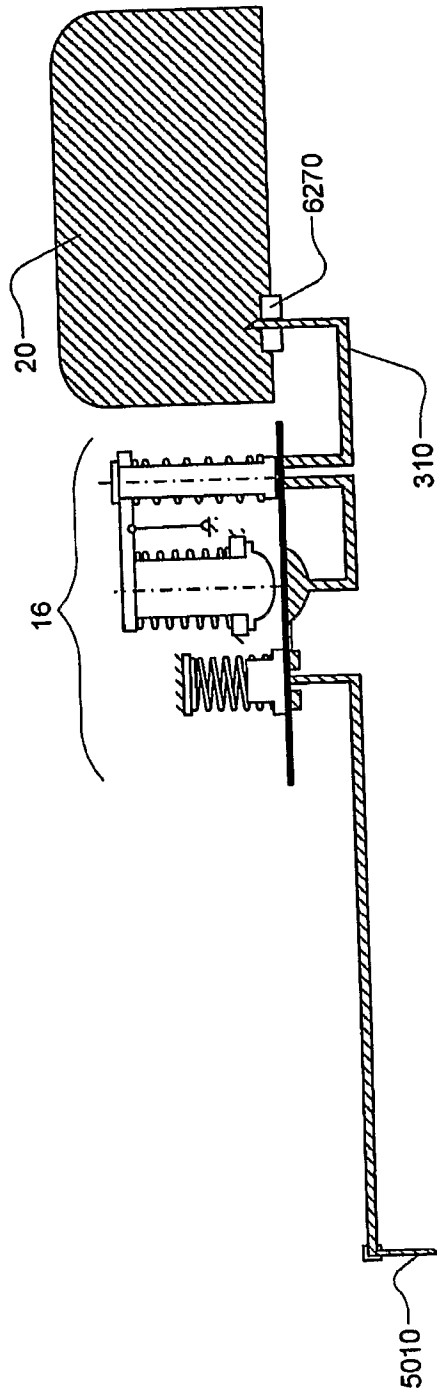

FIG. 59B

+

+

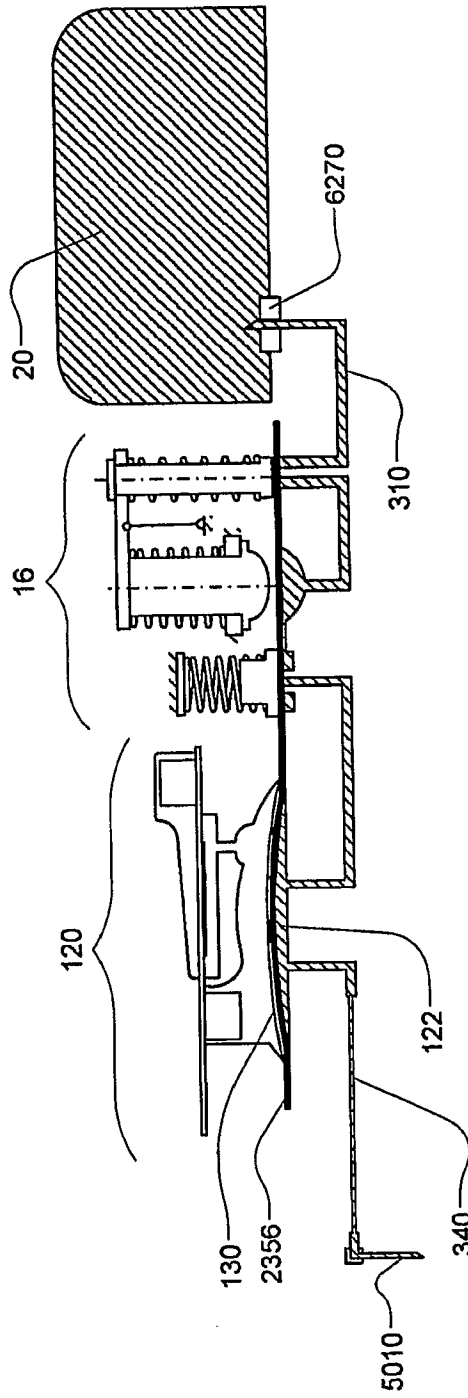

FIG. 59C

+

+

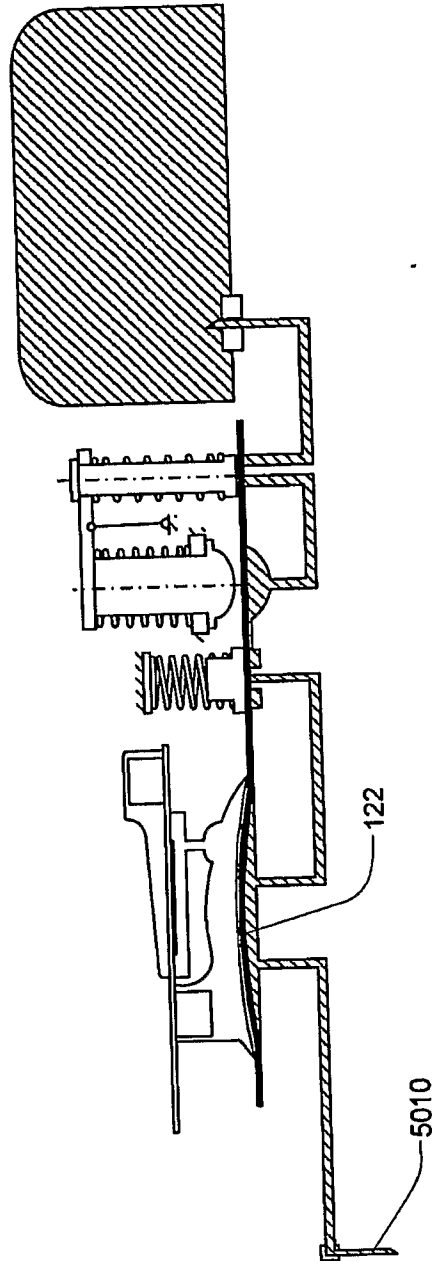

FIG. 59D

+

+

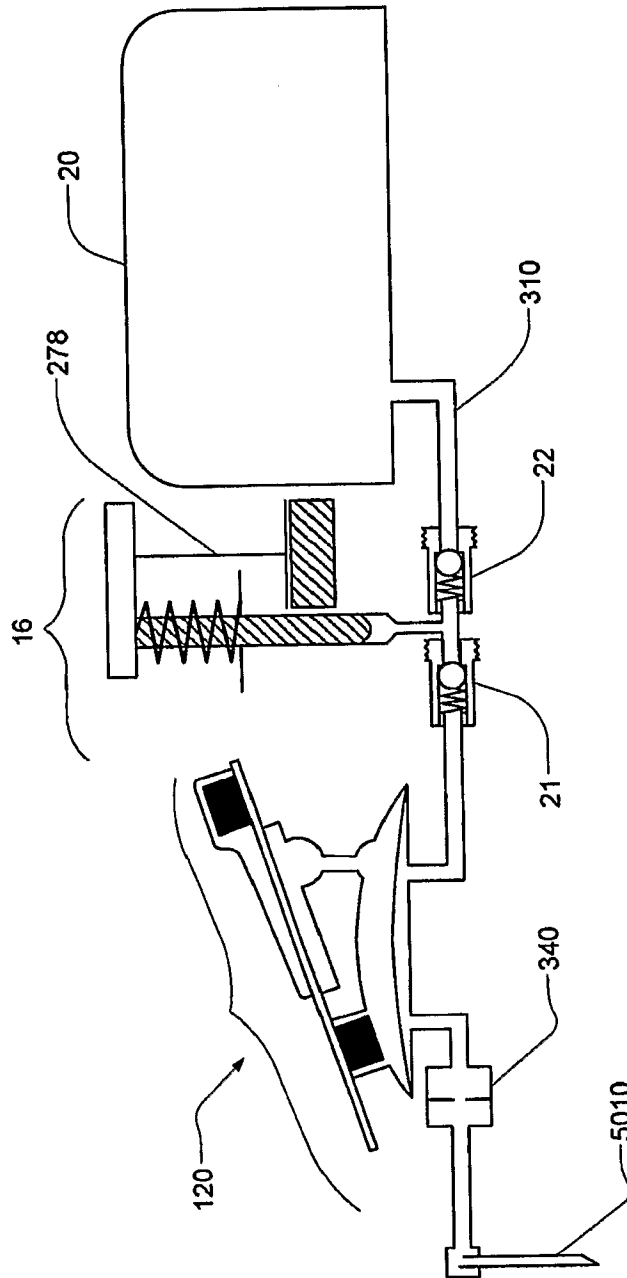

FIG. 59E

+

+

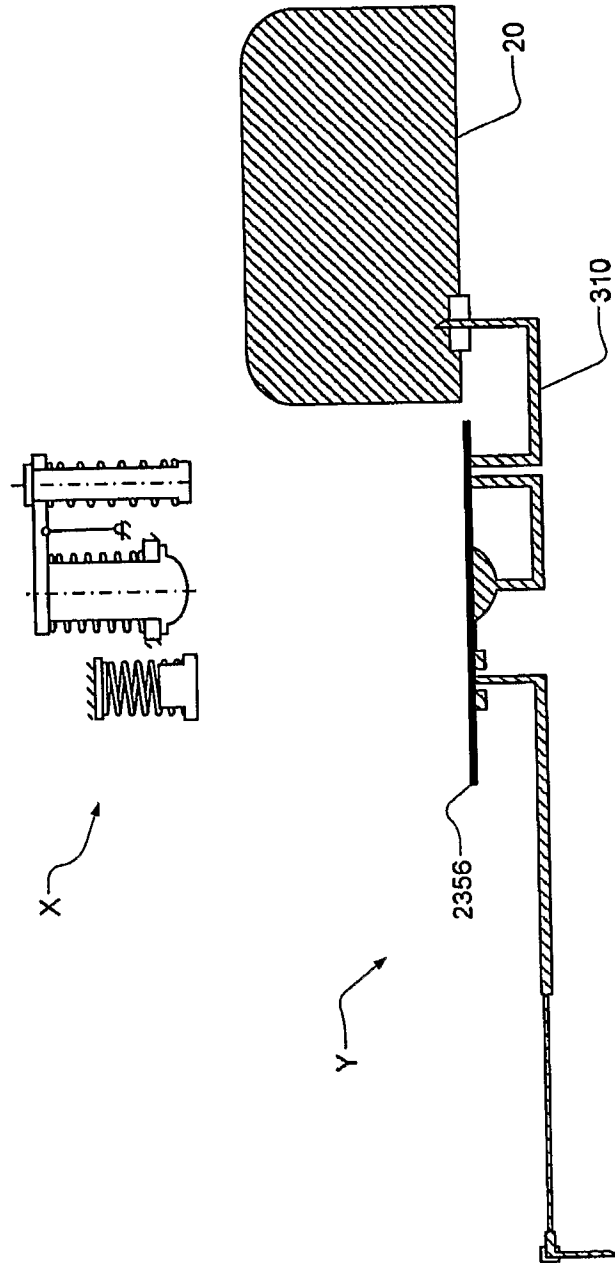

FIG. 60A

+

+

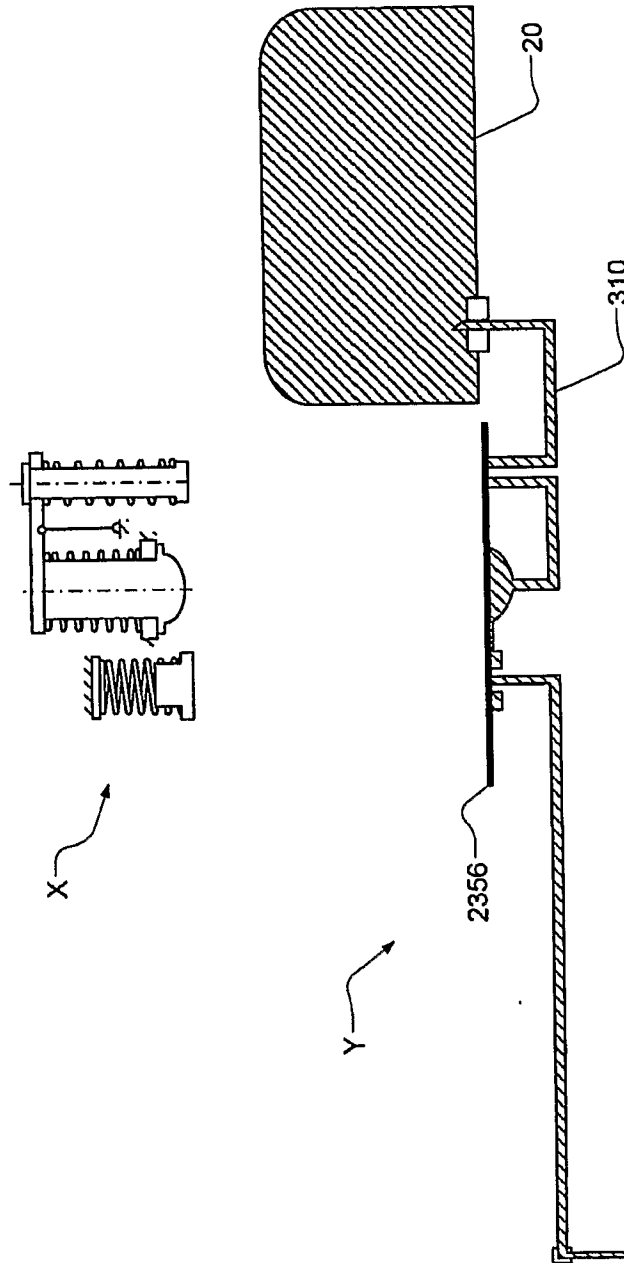

FIG. 60B

+

+

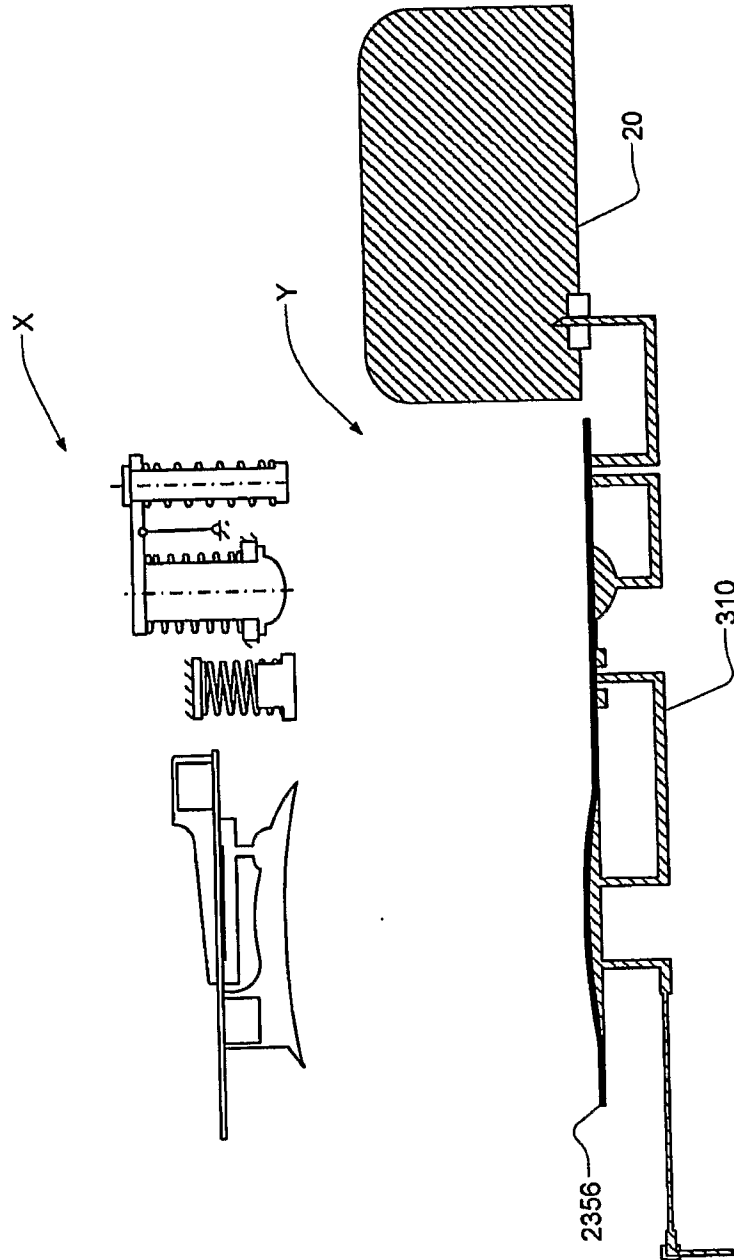

FIG. 60C

+

+

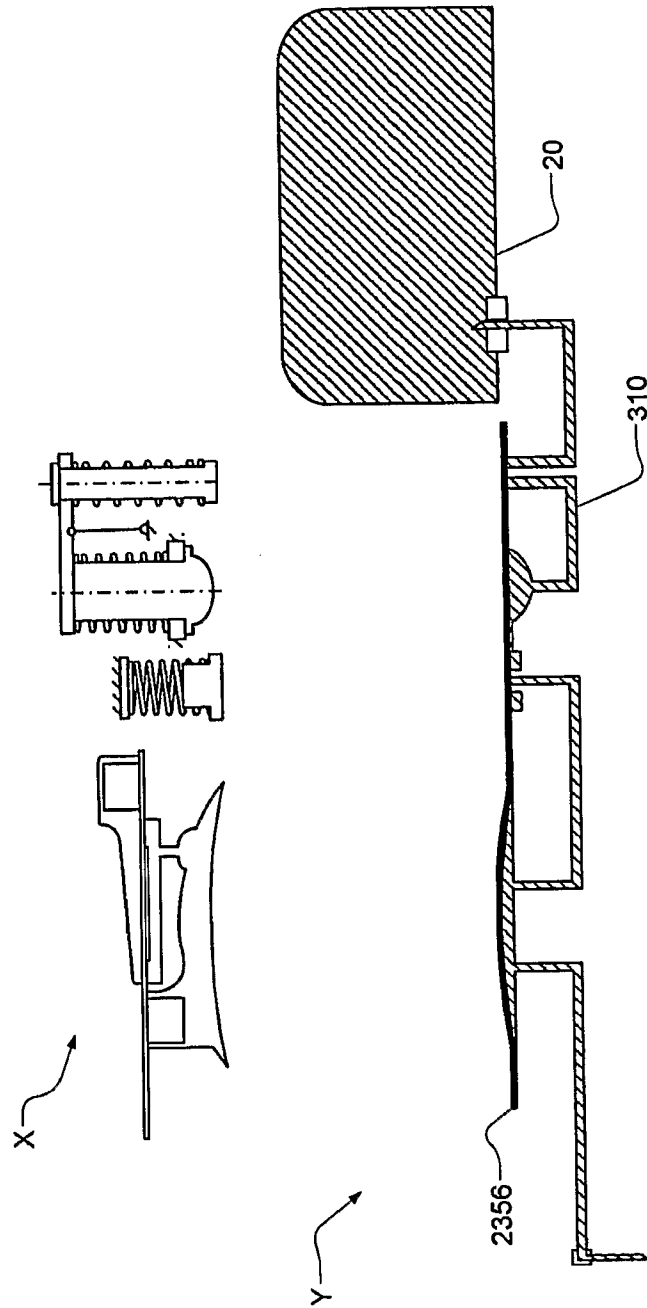

FIG. 60D

+



+

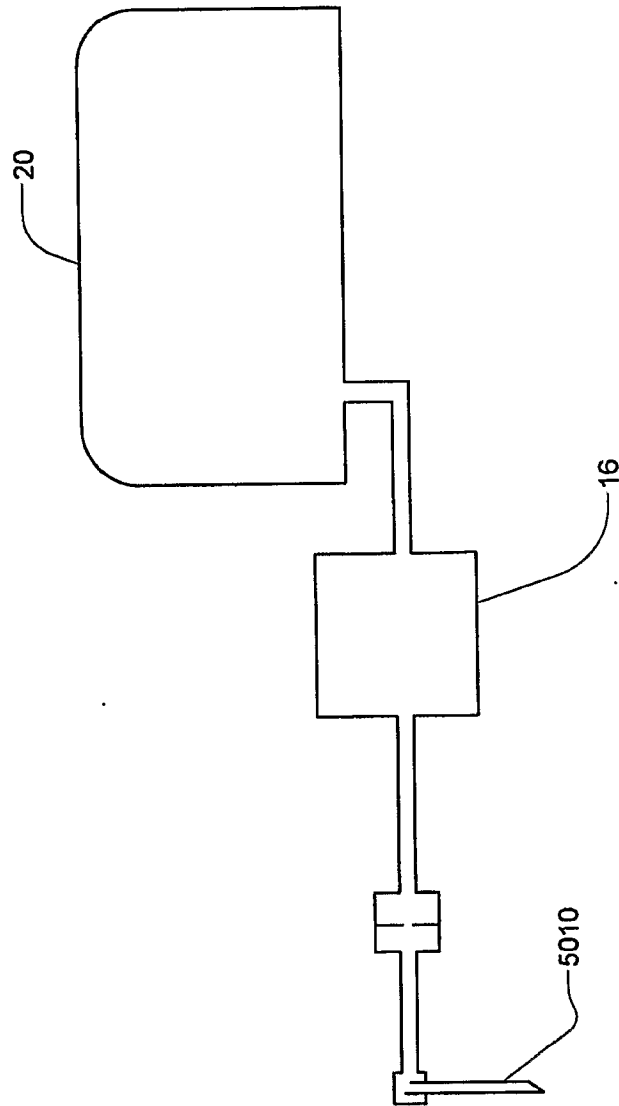

FIG. 61A

+

+

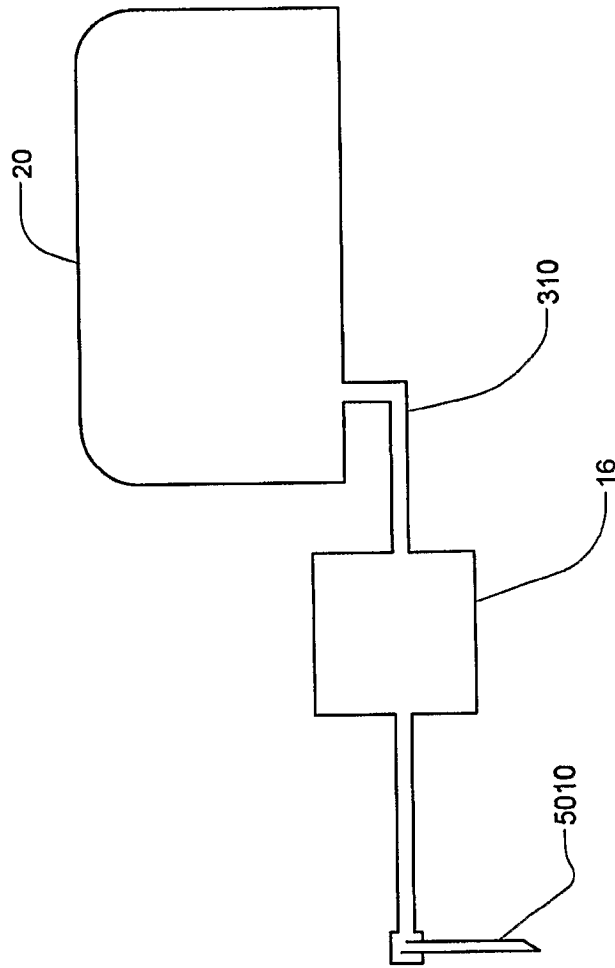

FIG. 61B

+

+

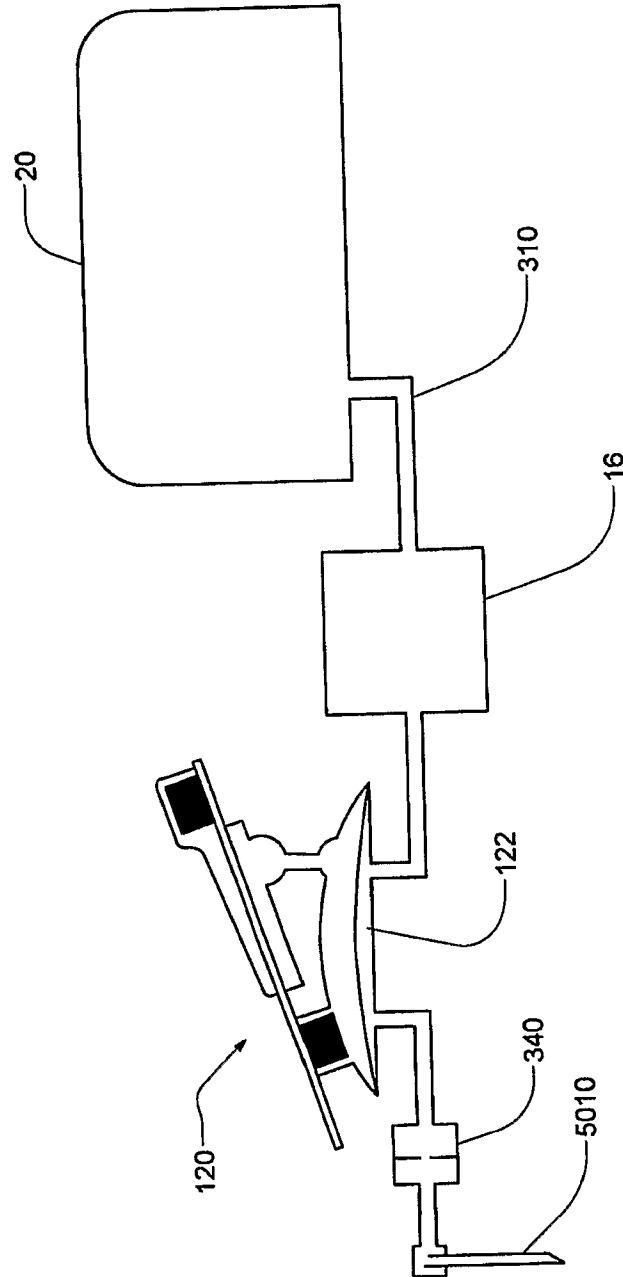
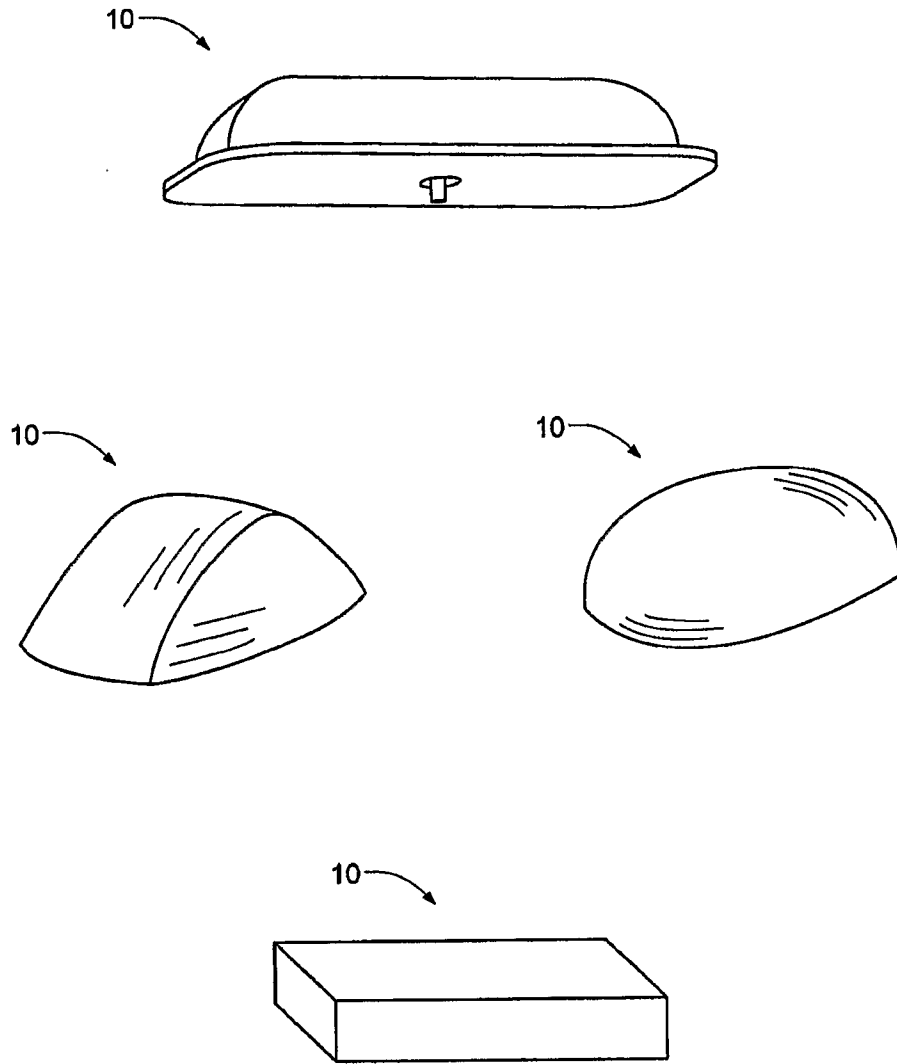

FIG. 61C

+

+



+

+

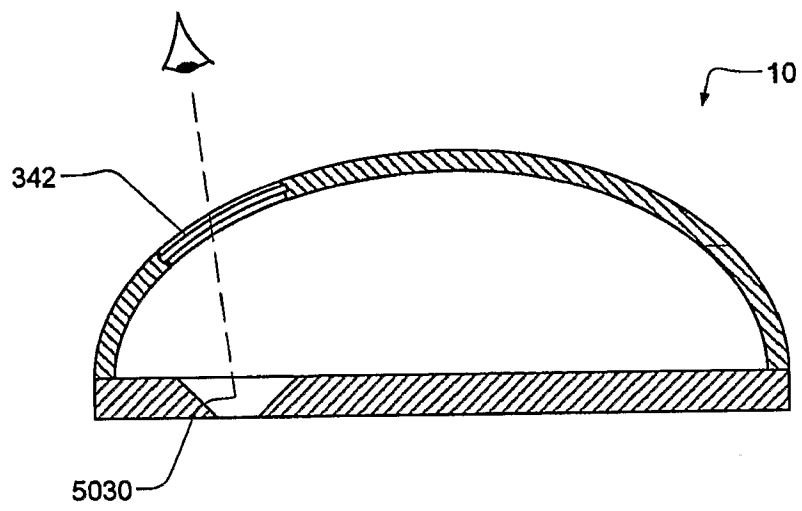

FIG. 62B

+

+

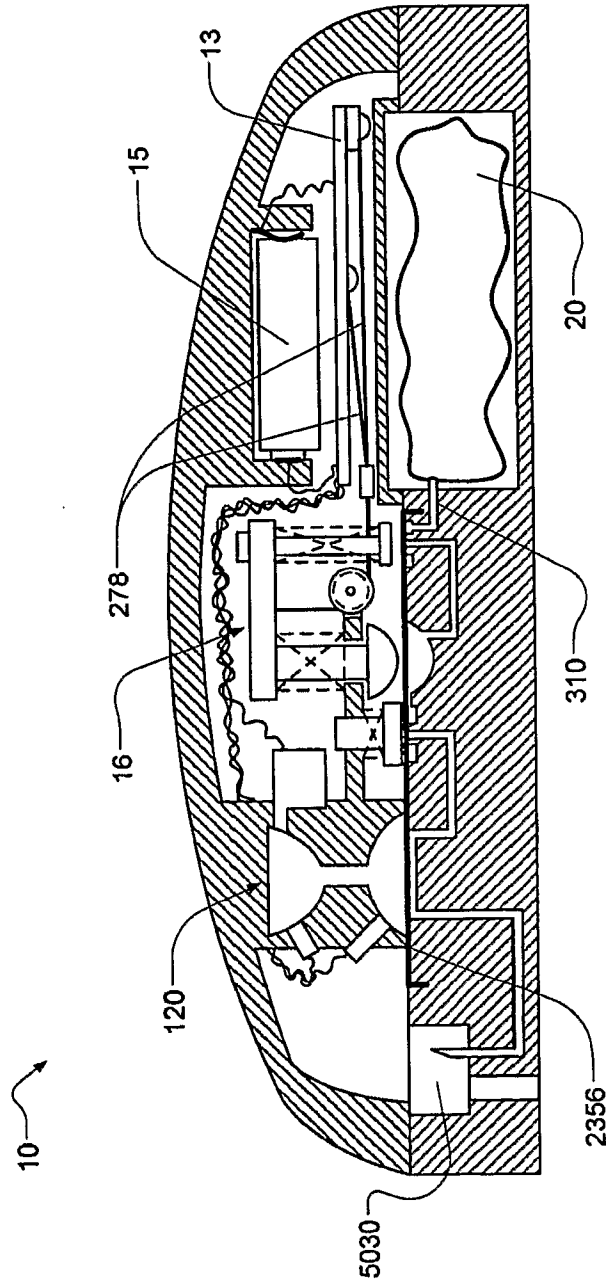

FIG. 63A

+

+

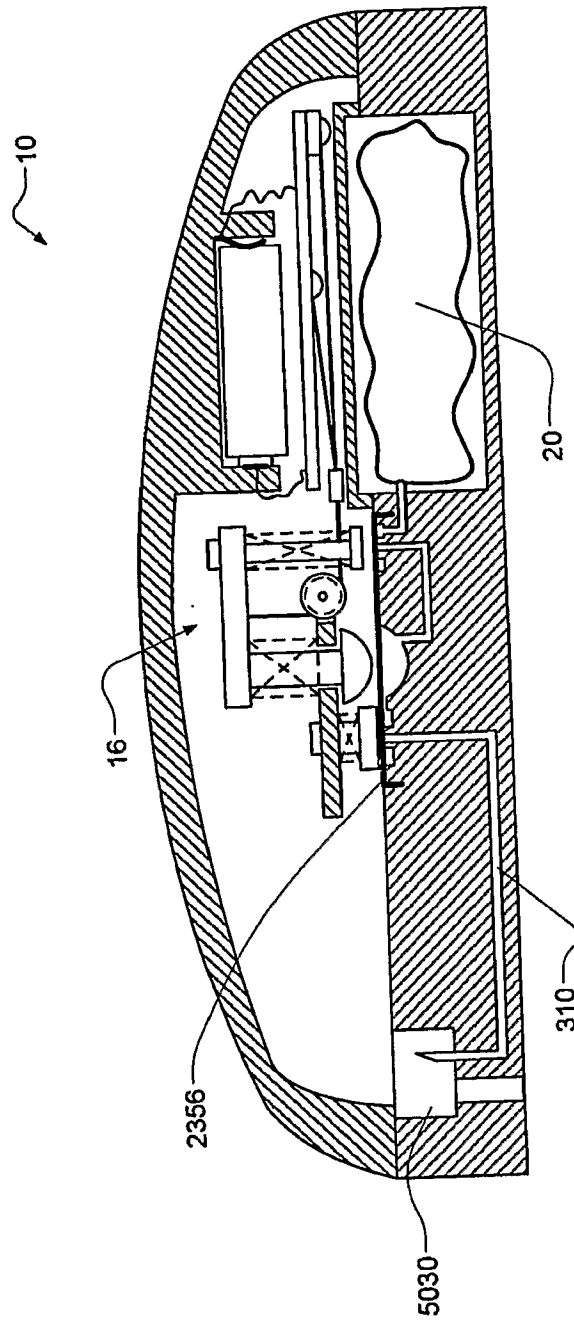

FIG. 63B

+

+

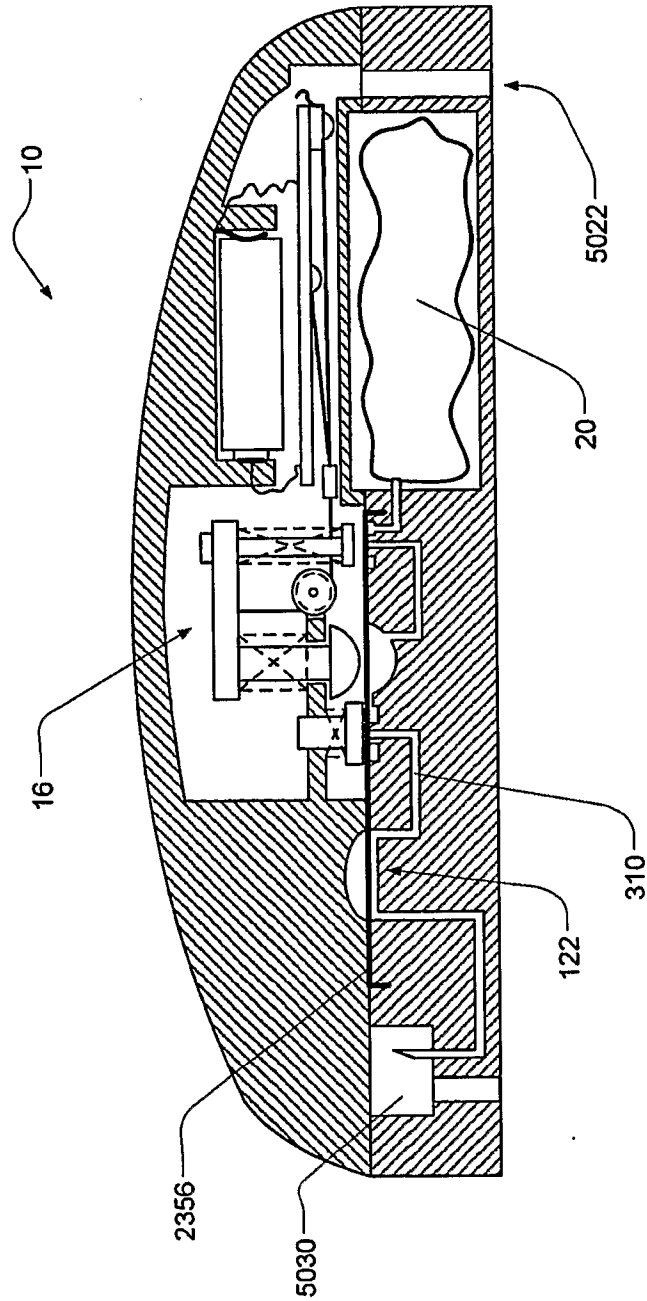

FIG. 63C

+



+

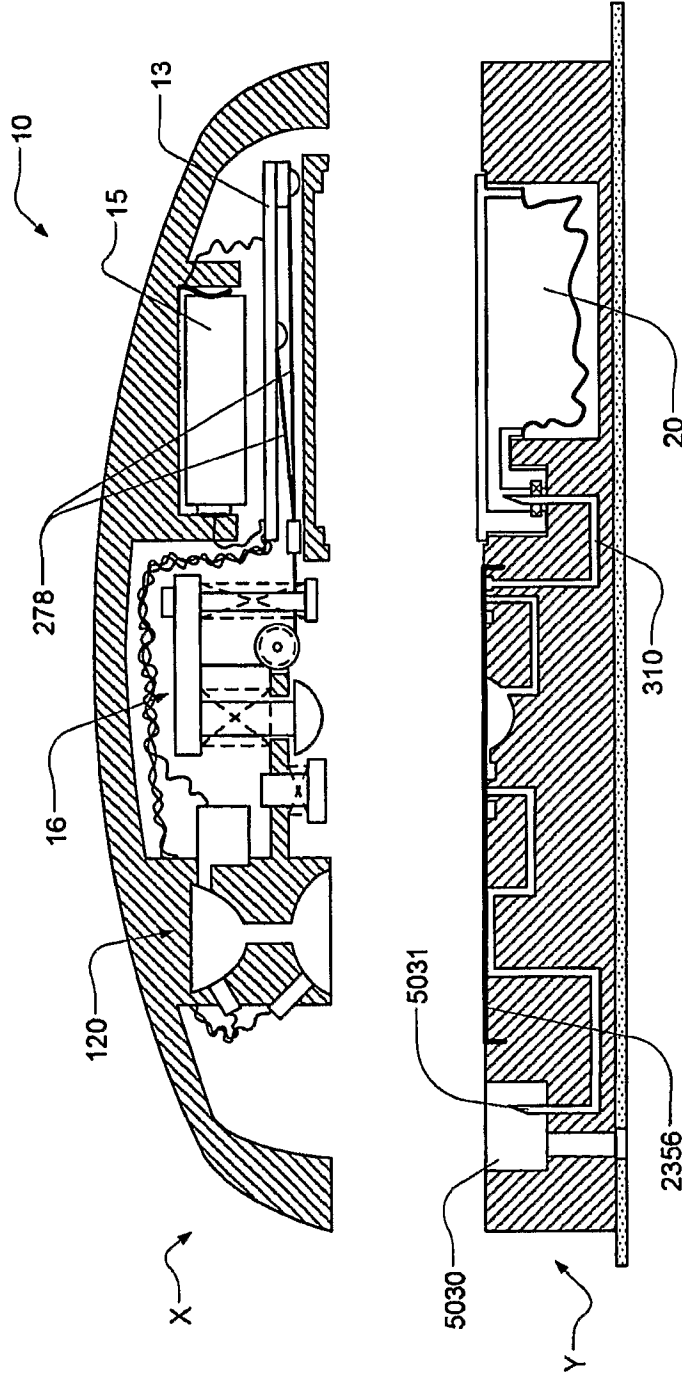

FIG. 64A

+

+

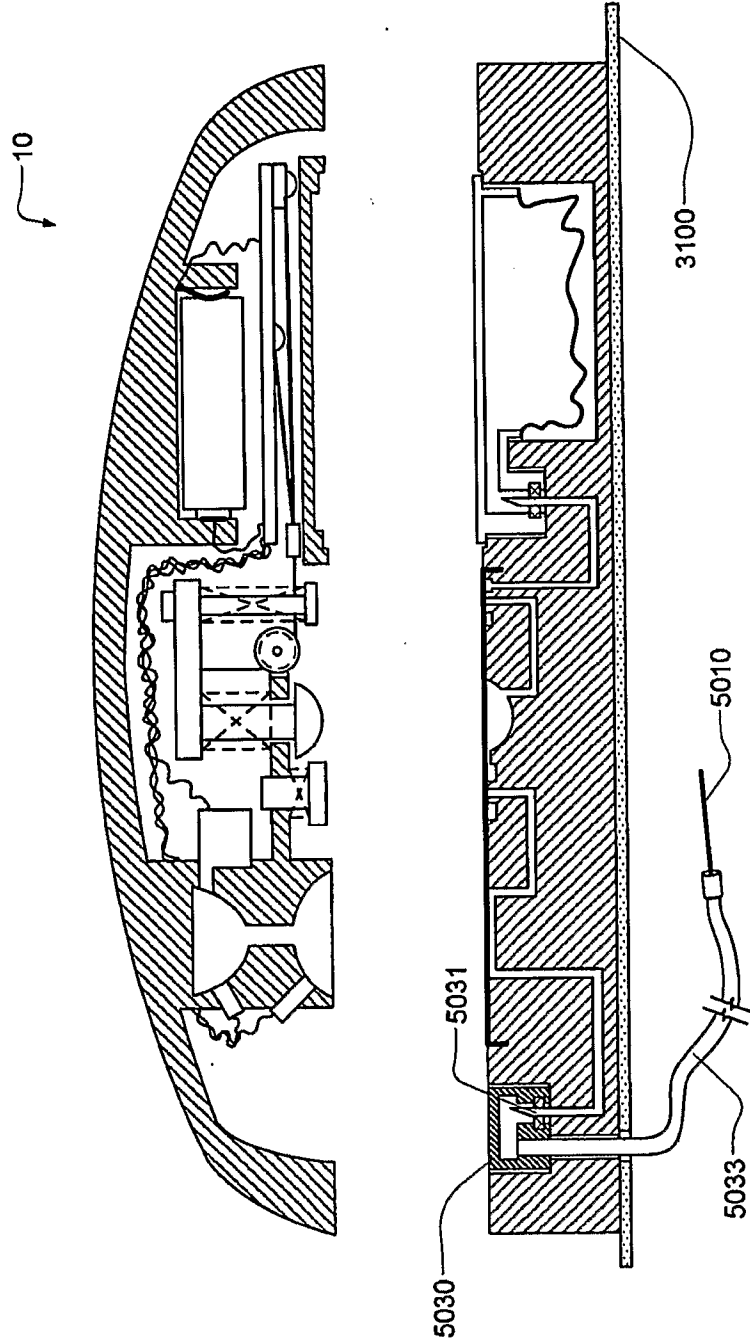

FIG. 64B

+

+

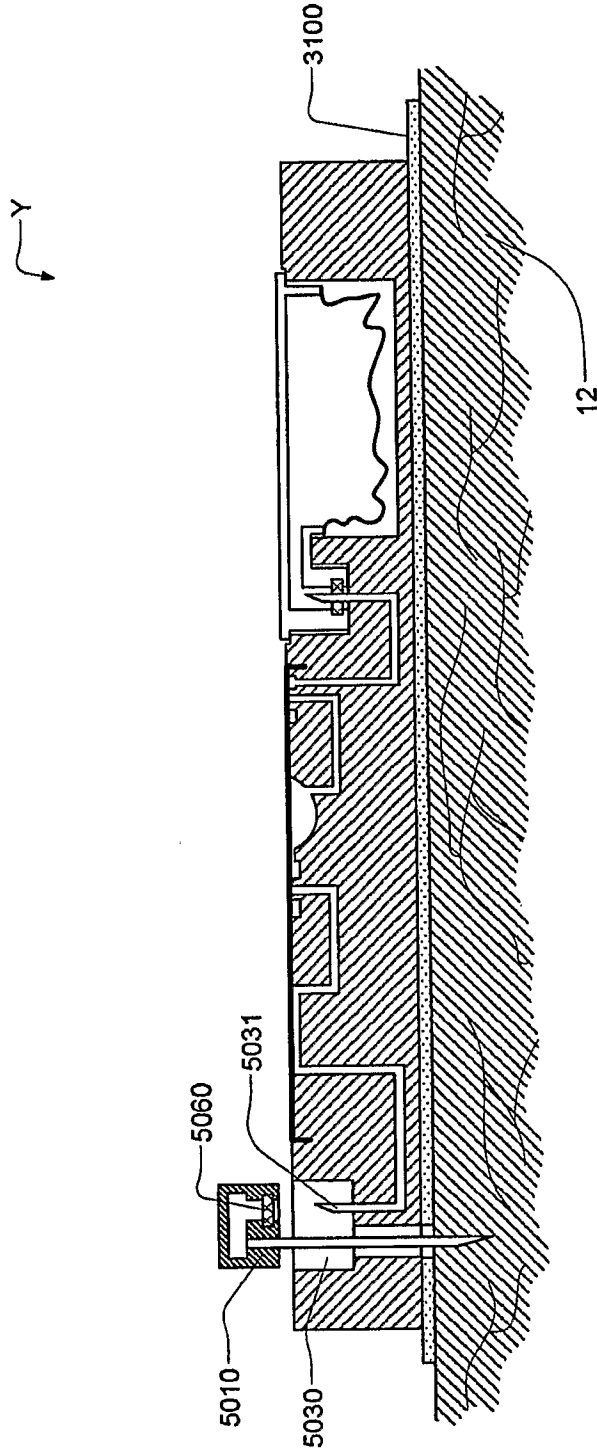

FIG. 64C

+

+

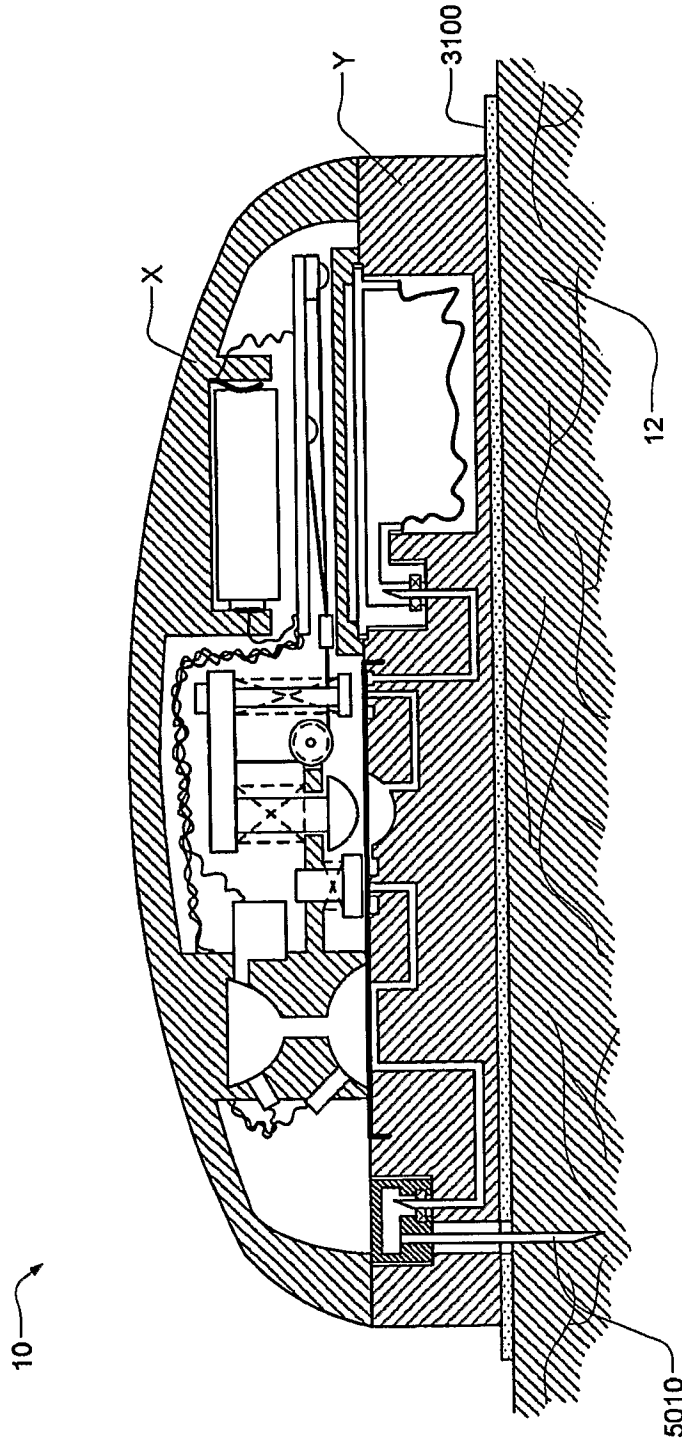

FIG. 64D

+

+

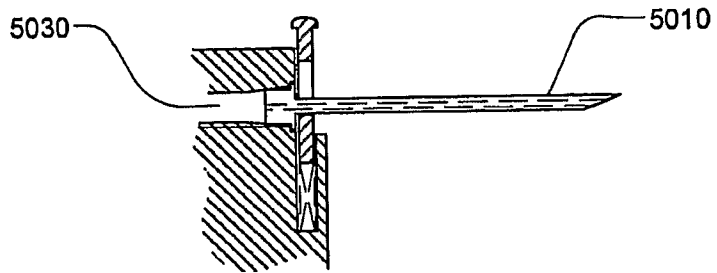

FIG. 65A

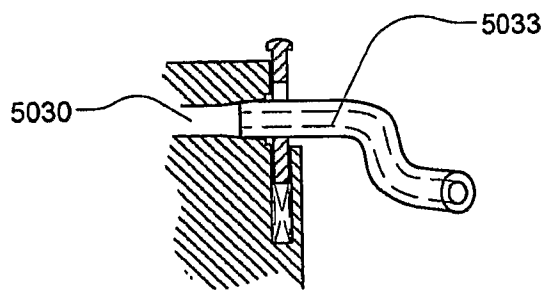

FIG. 65B

+

+

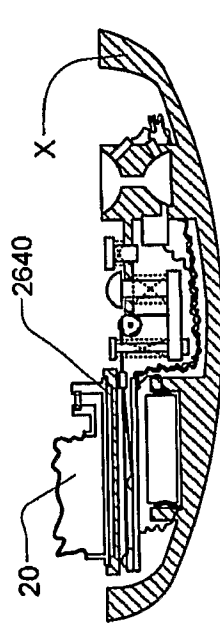
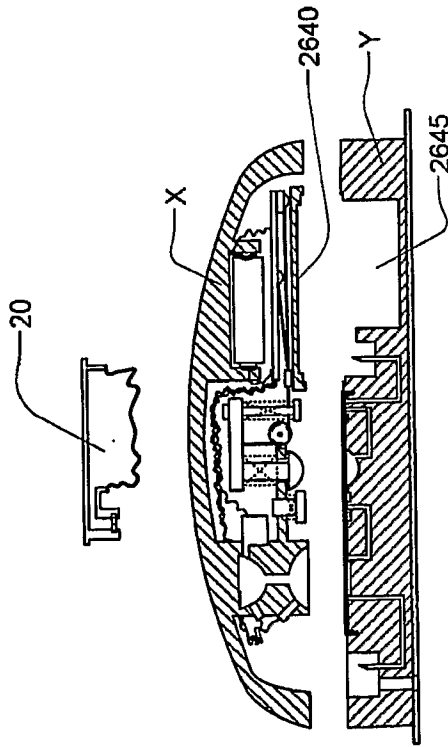

FIG. 66B

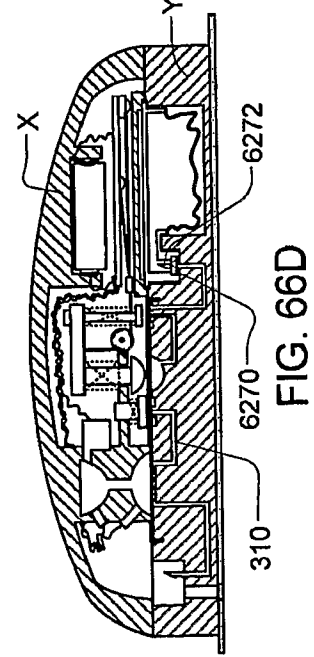
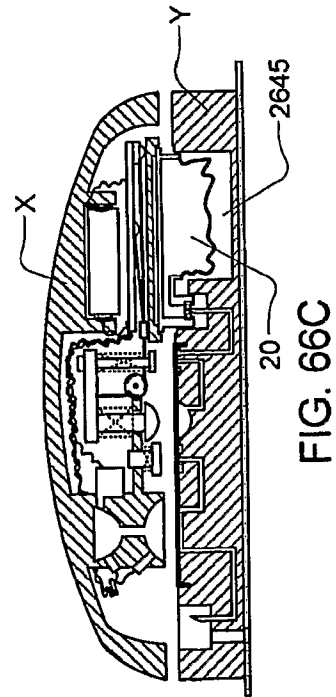

FIG. 66D

+

+

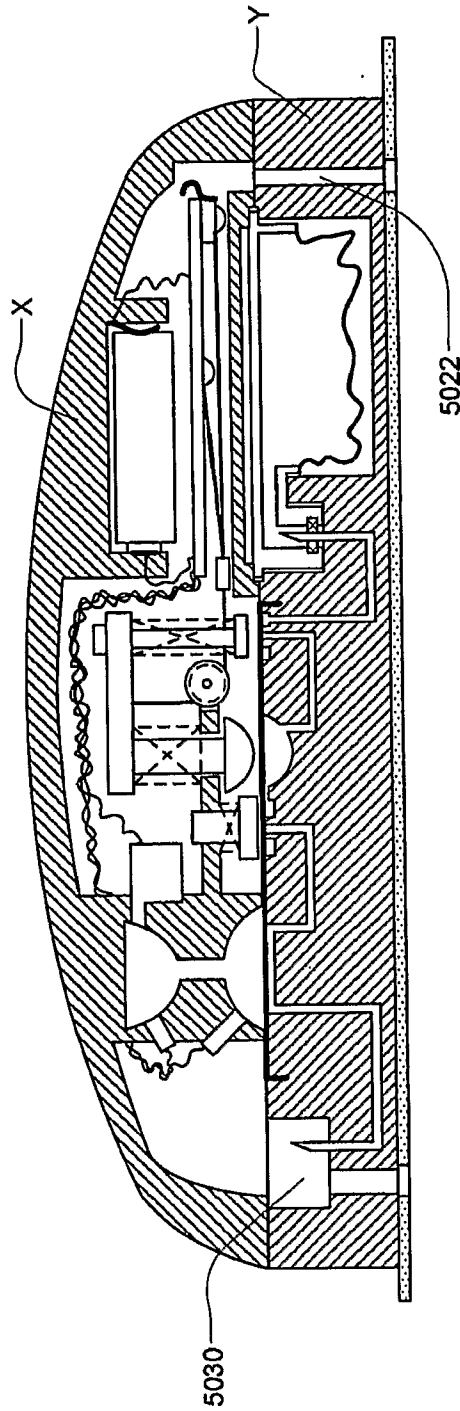

FIG. 67A

+

+

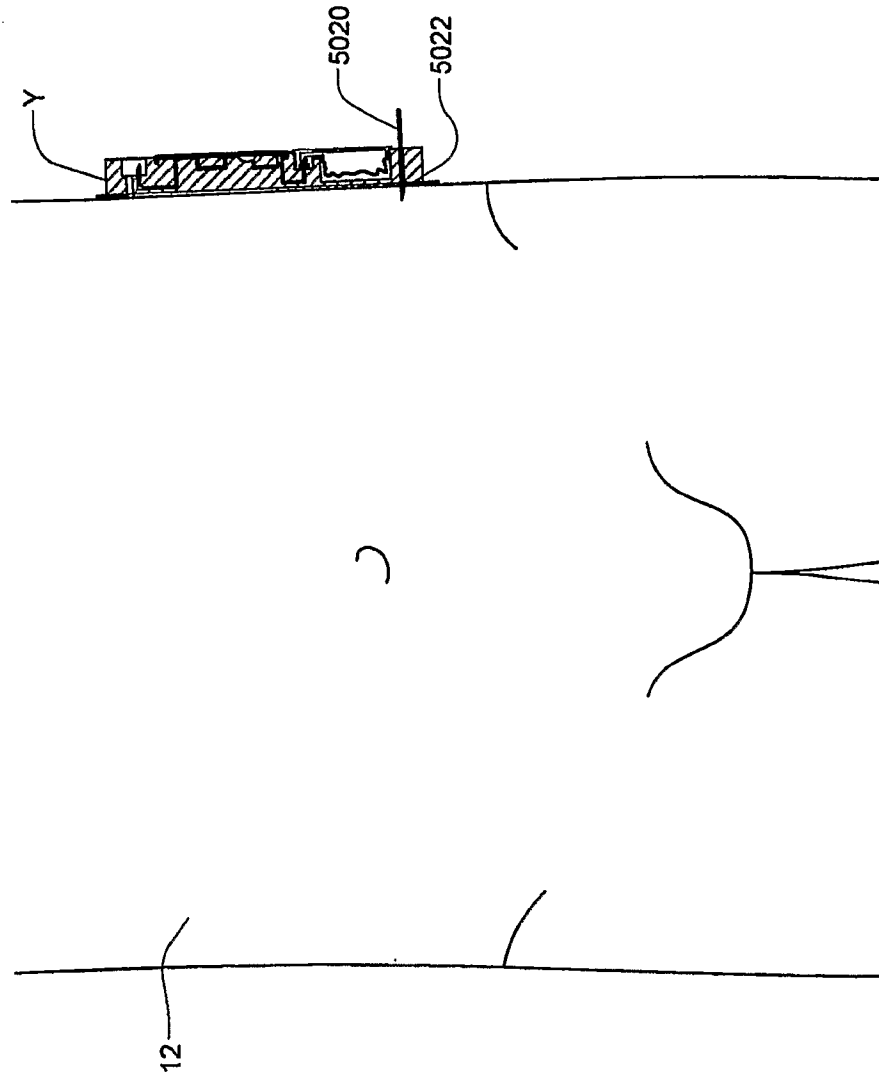

FIG. 67B

+



+

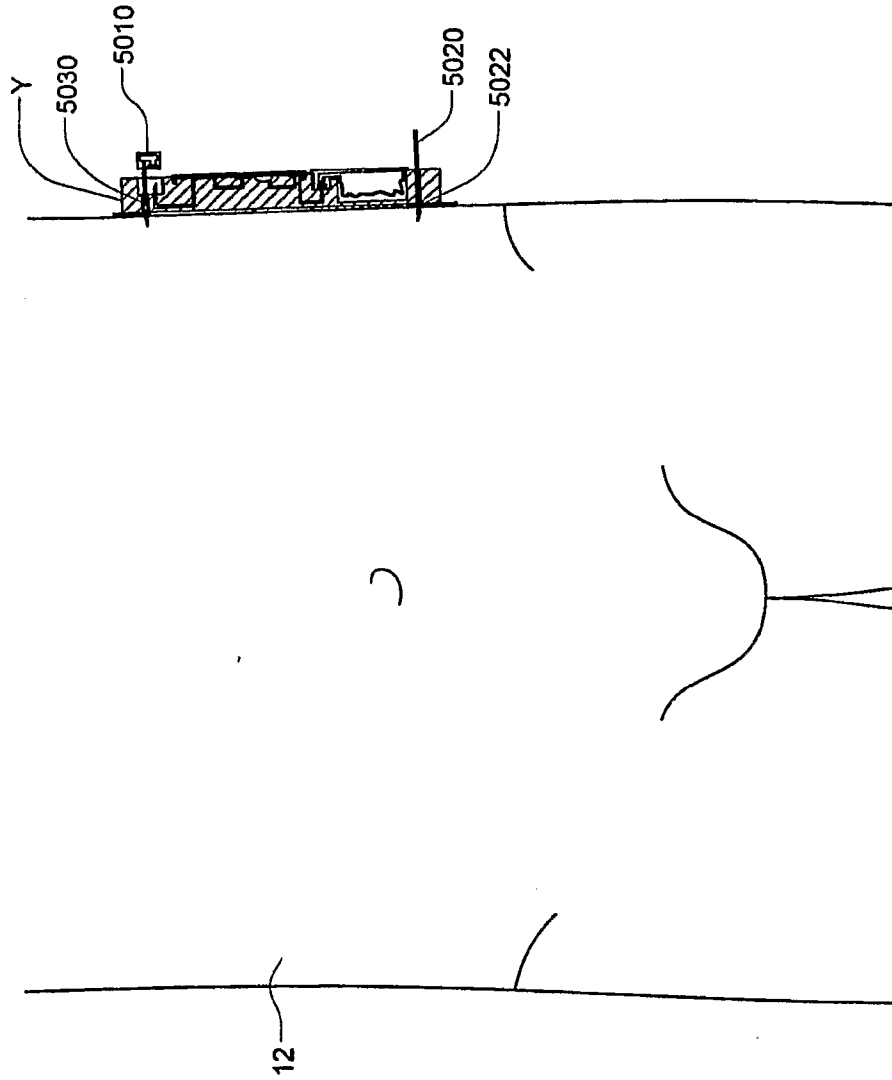
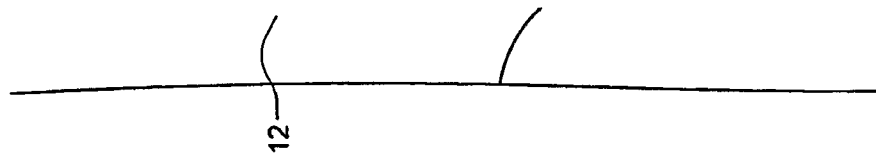
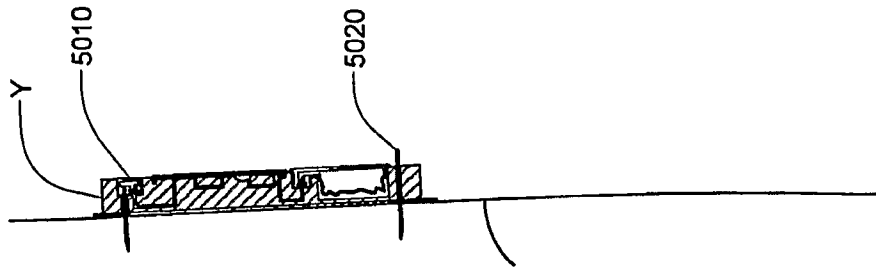

FIG. 67C

+

+



~

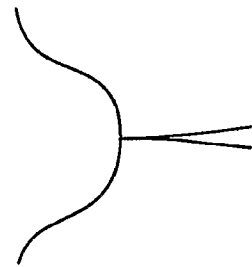

FIG. 67D

+

+

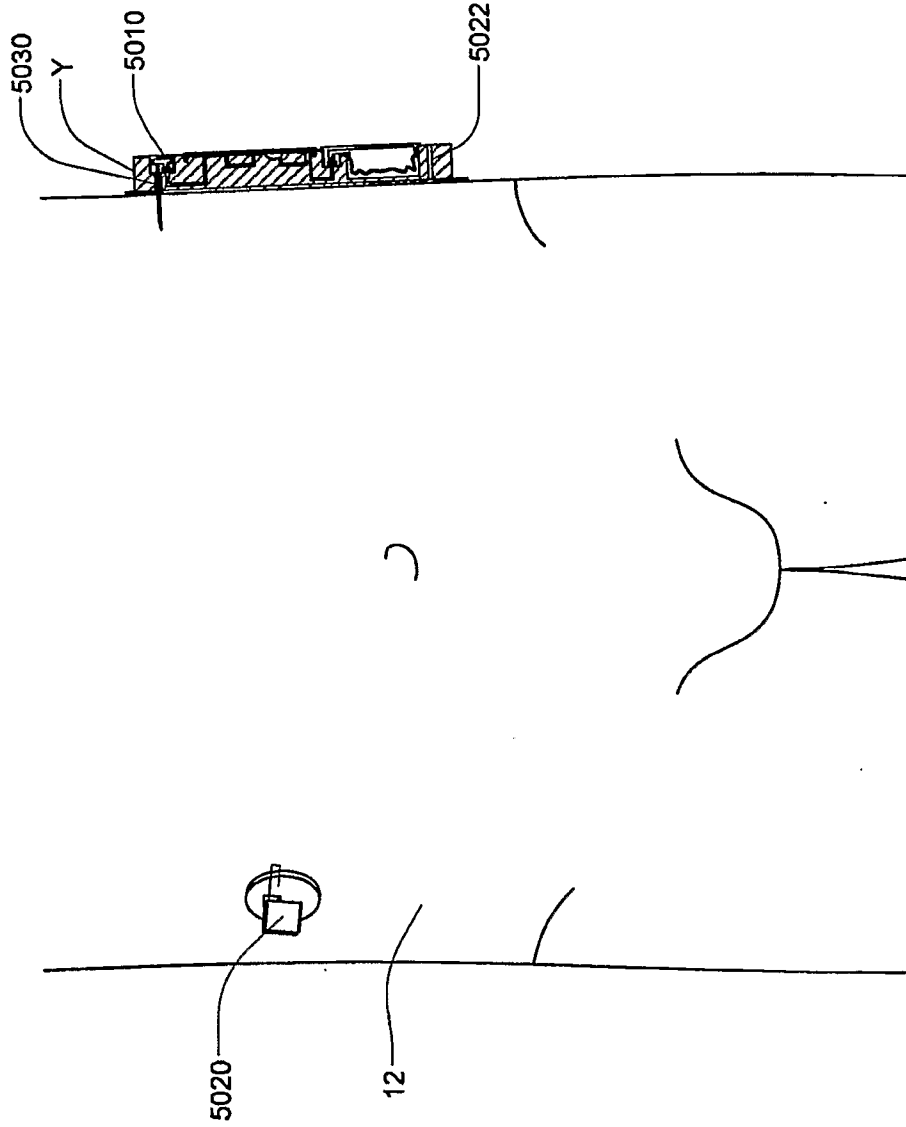

FIG. 67E

+

+

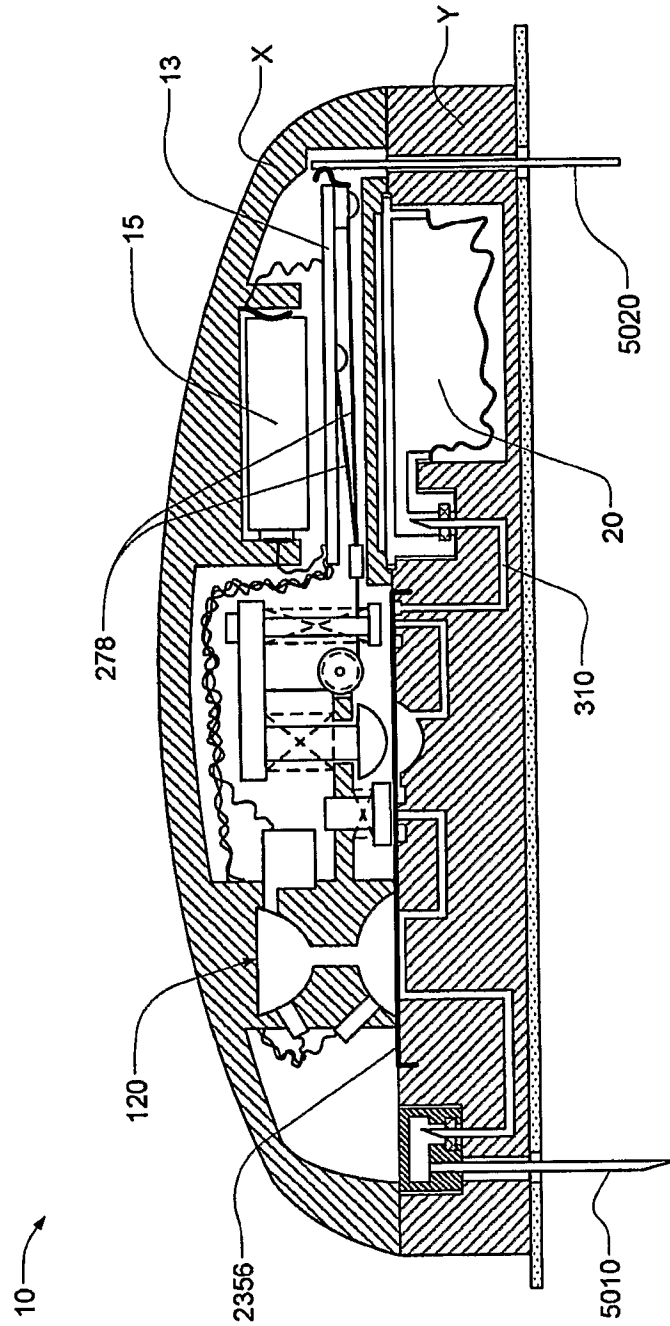

FIG. 67F

+

+

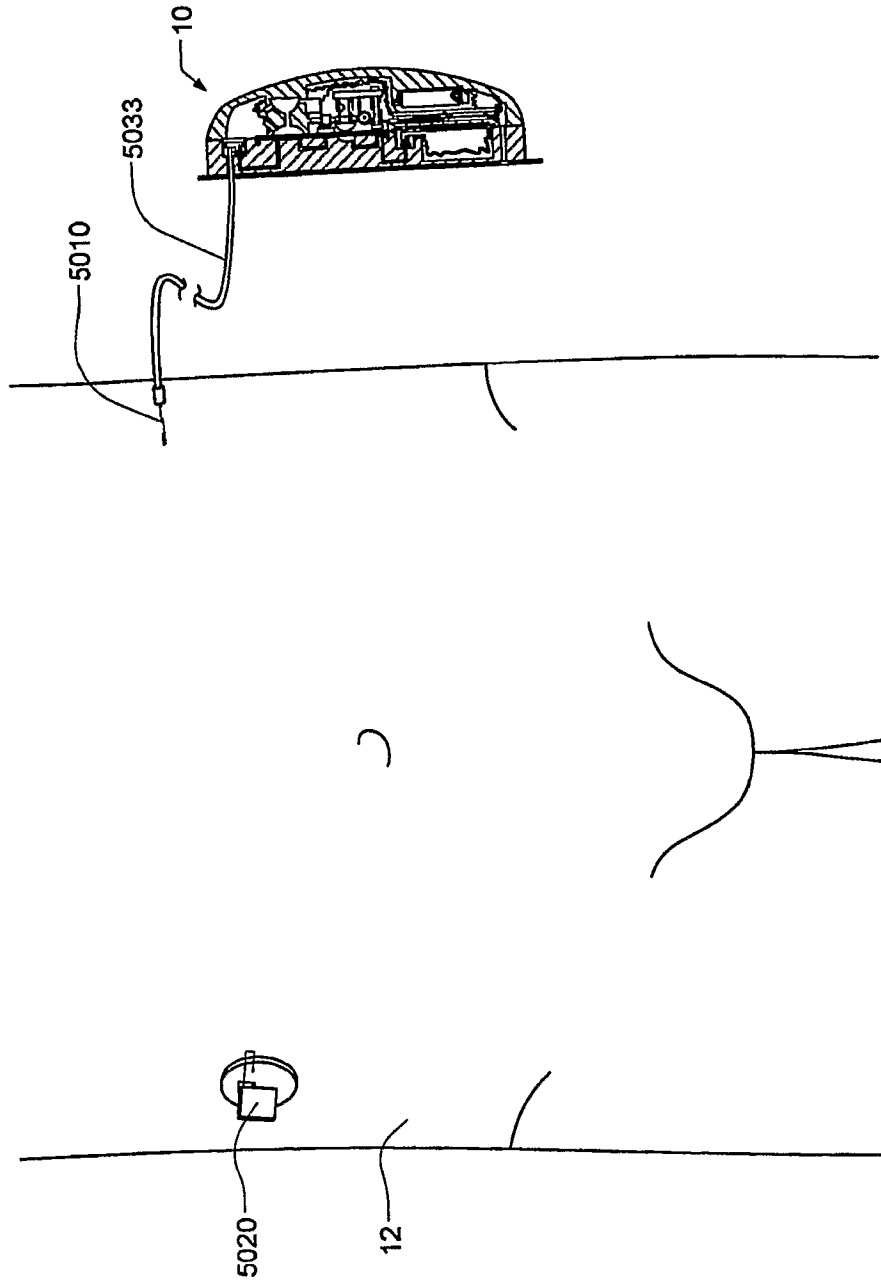

FIG. 68

+

+

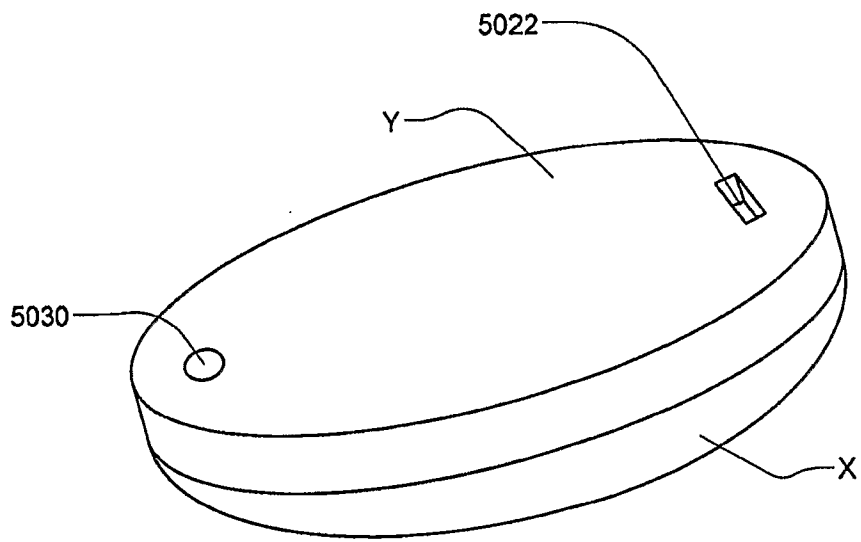

FIG. 69A

+

+

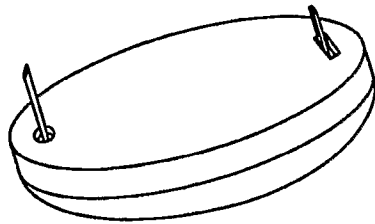

FIG. 69B

+

+

FIG. 70A	FIG. 70B
FIG. 70C	FIG. 70D

FIG. 70

+



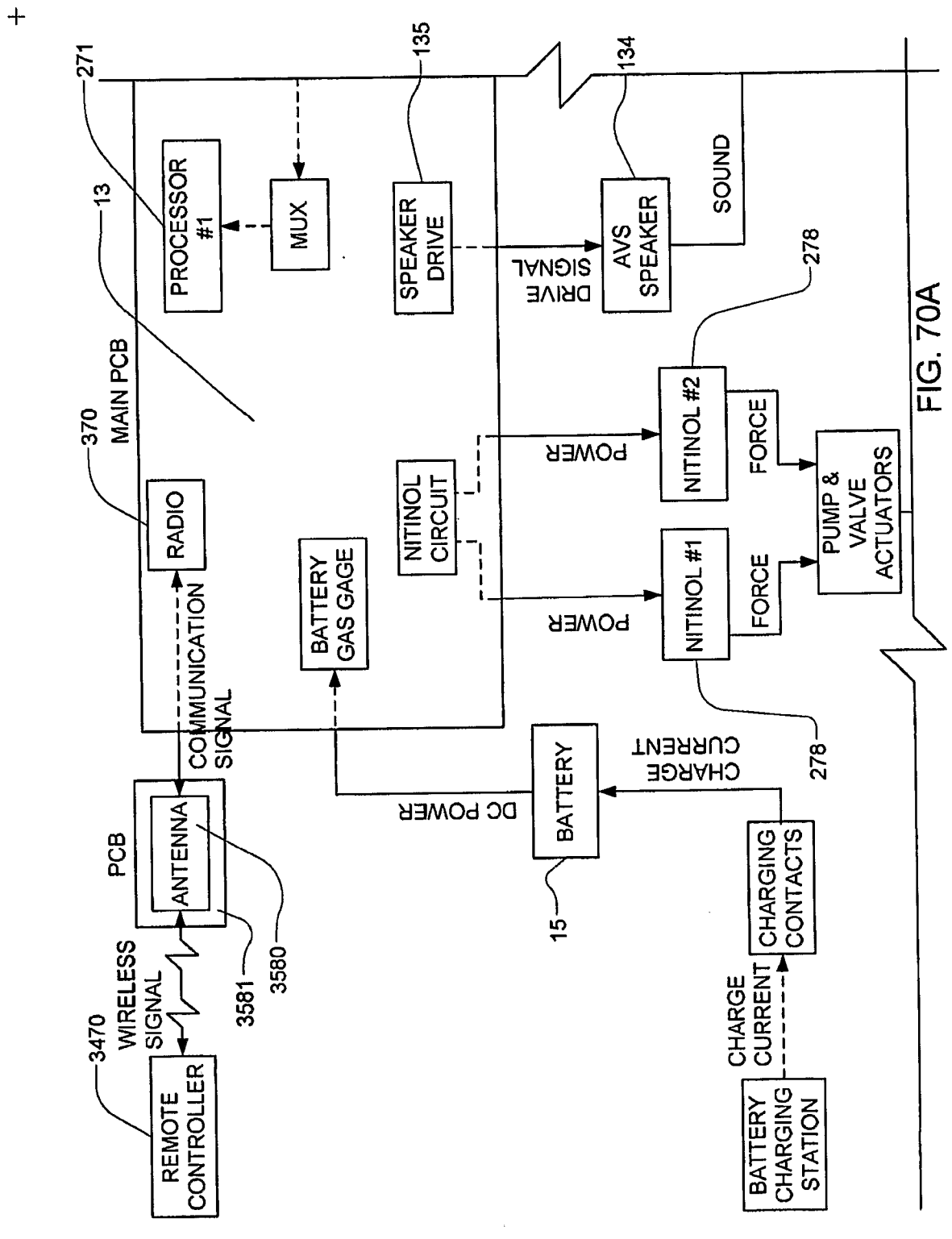

FIG. 70A

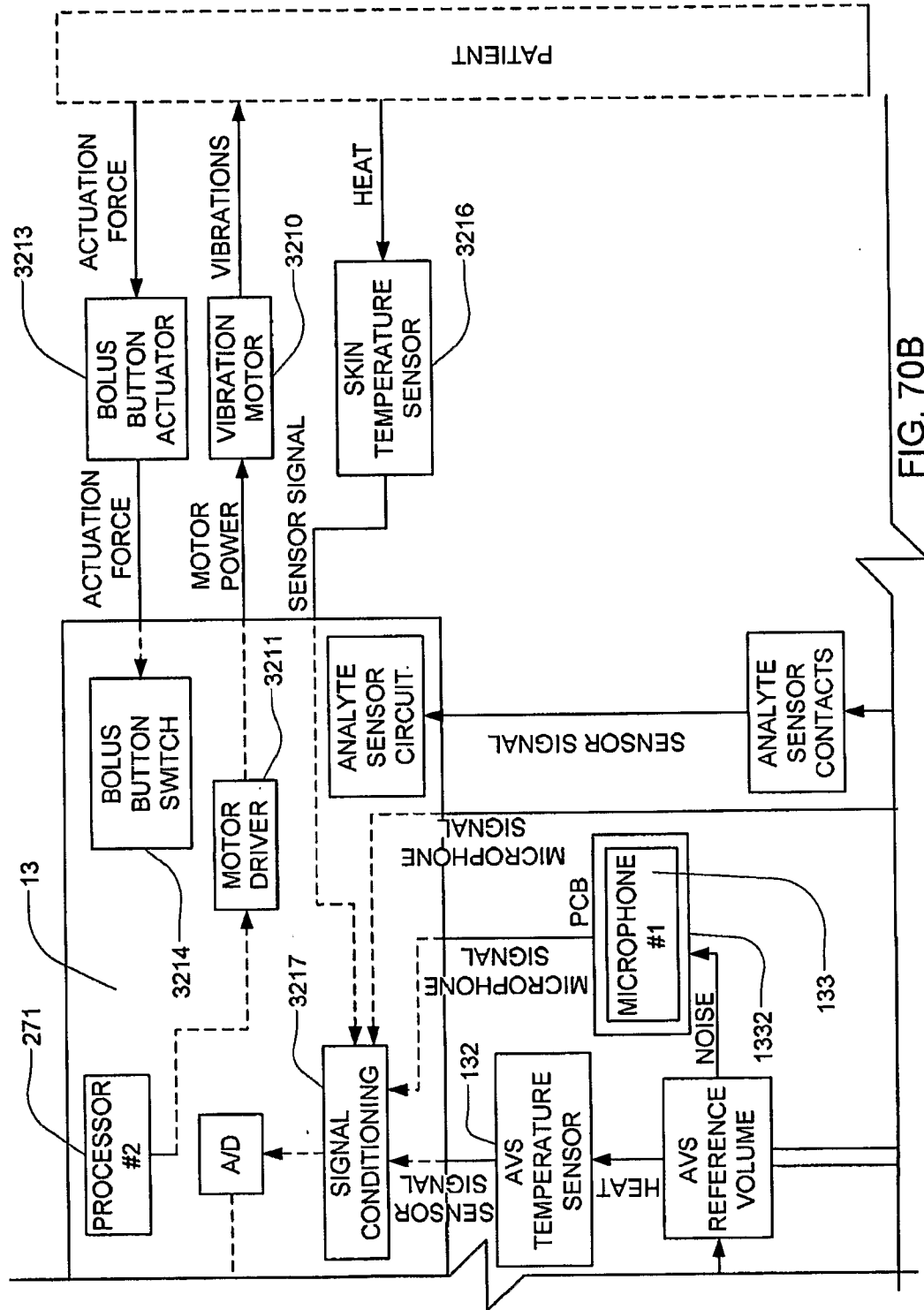

FIG. 70B

+

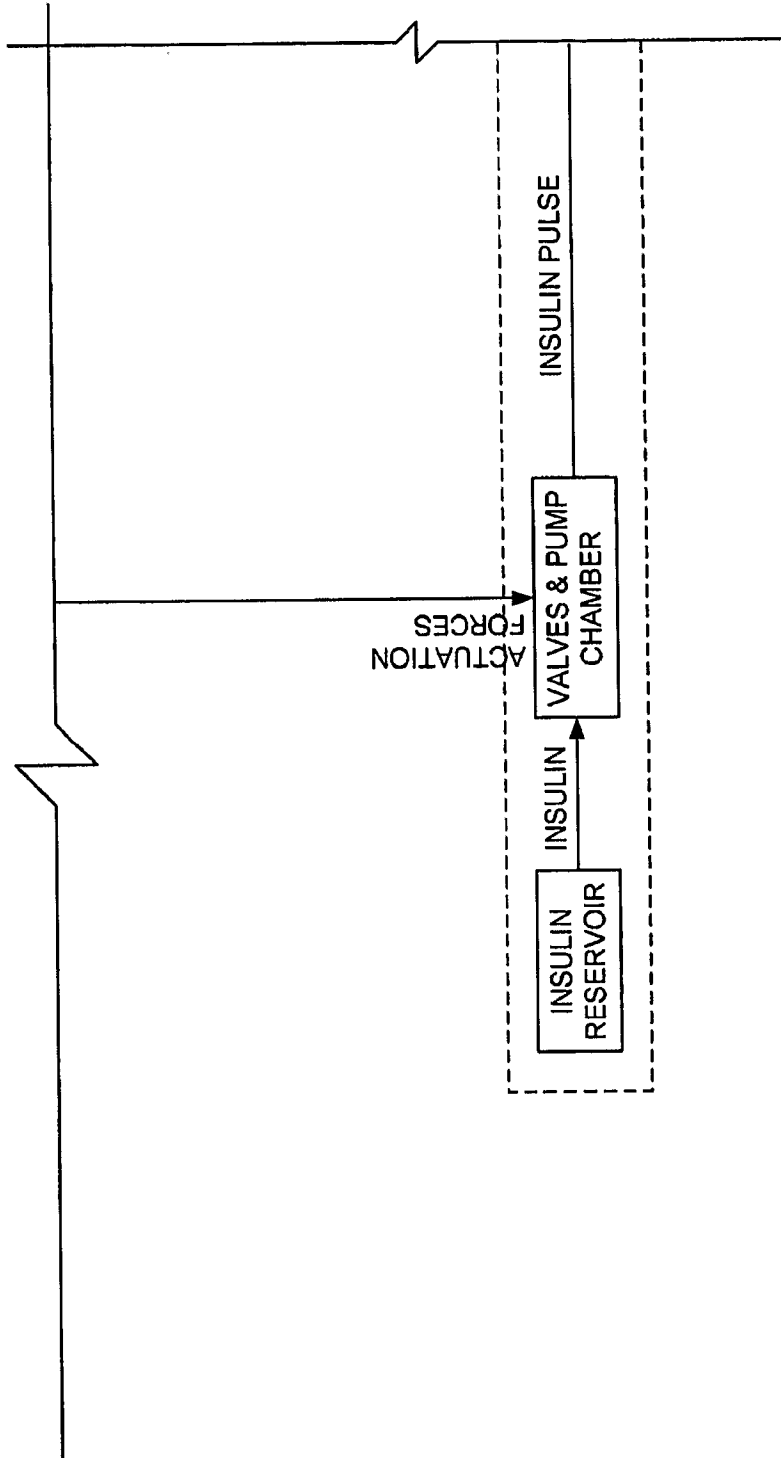

FIG. 70C

+

+

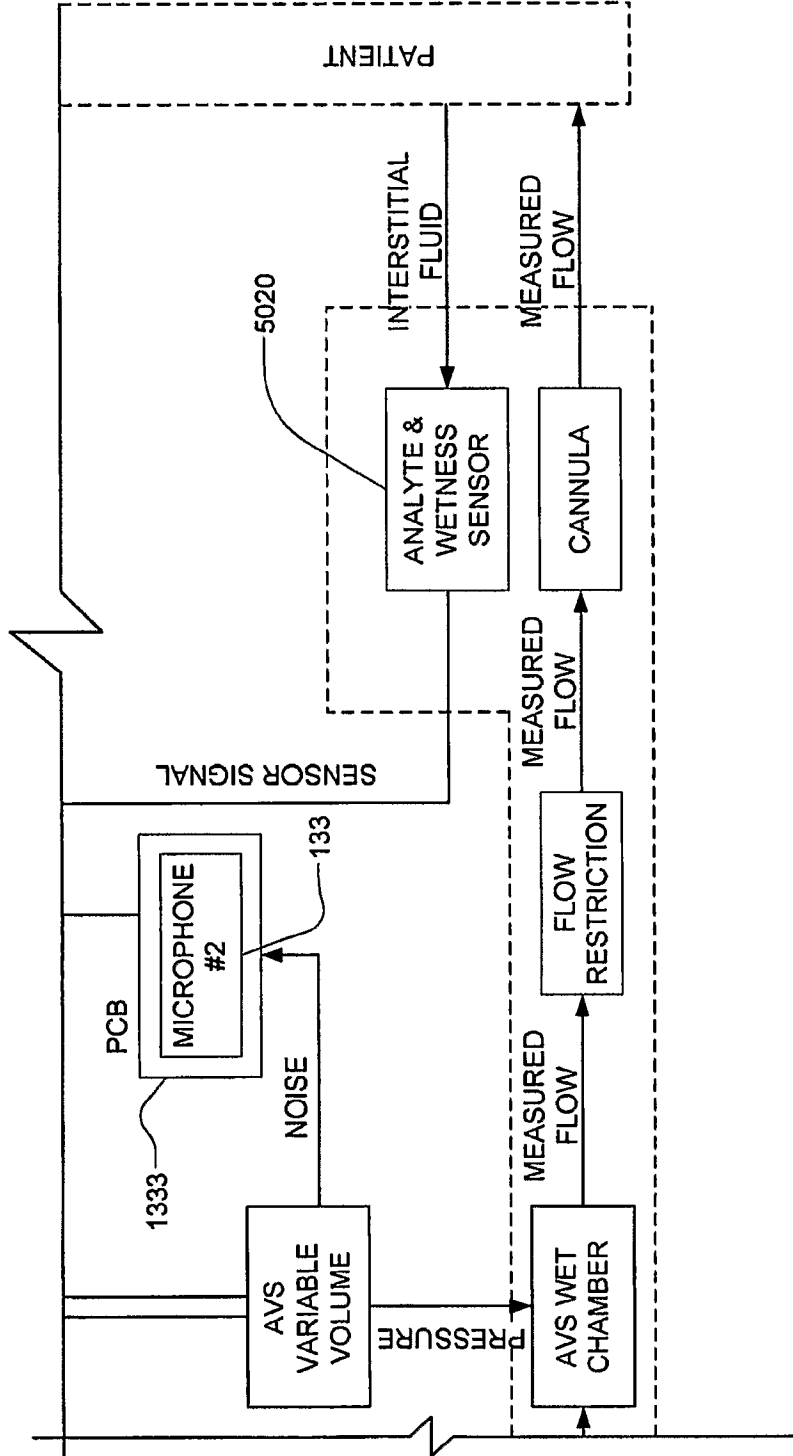

FIG. 70D

+

+

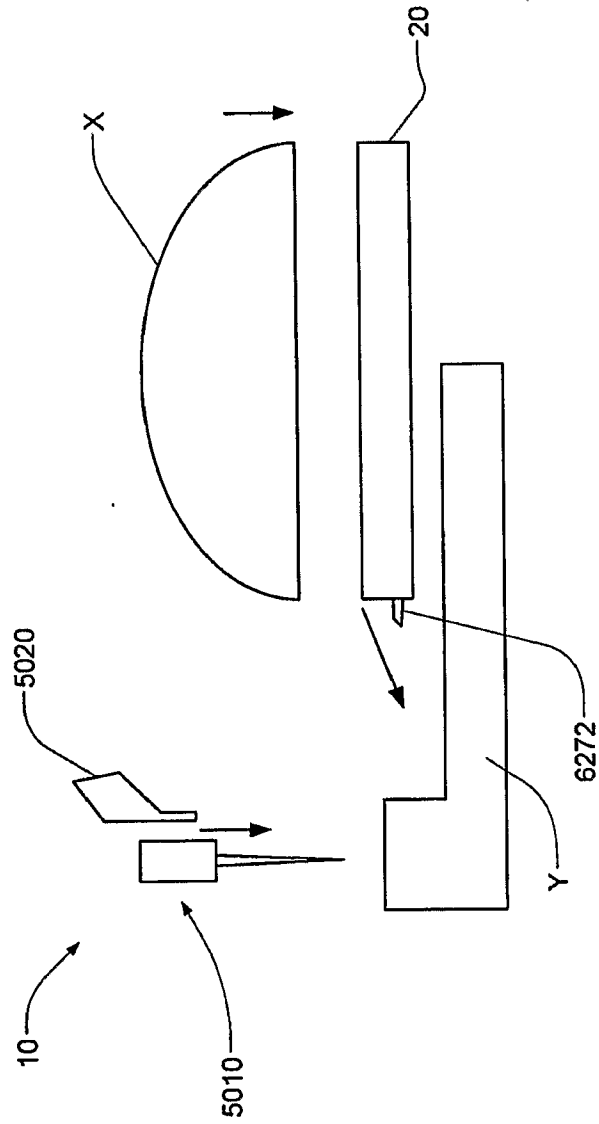

FIG. 71

+

+

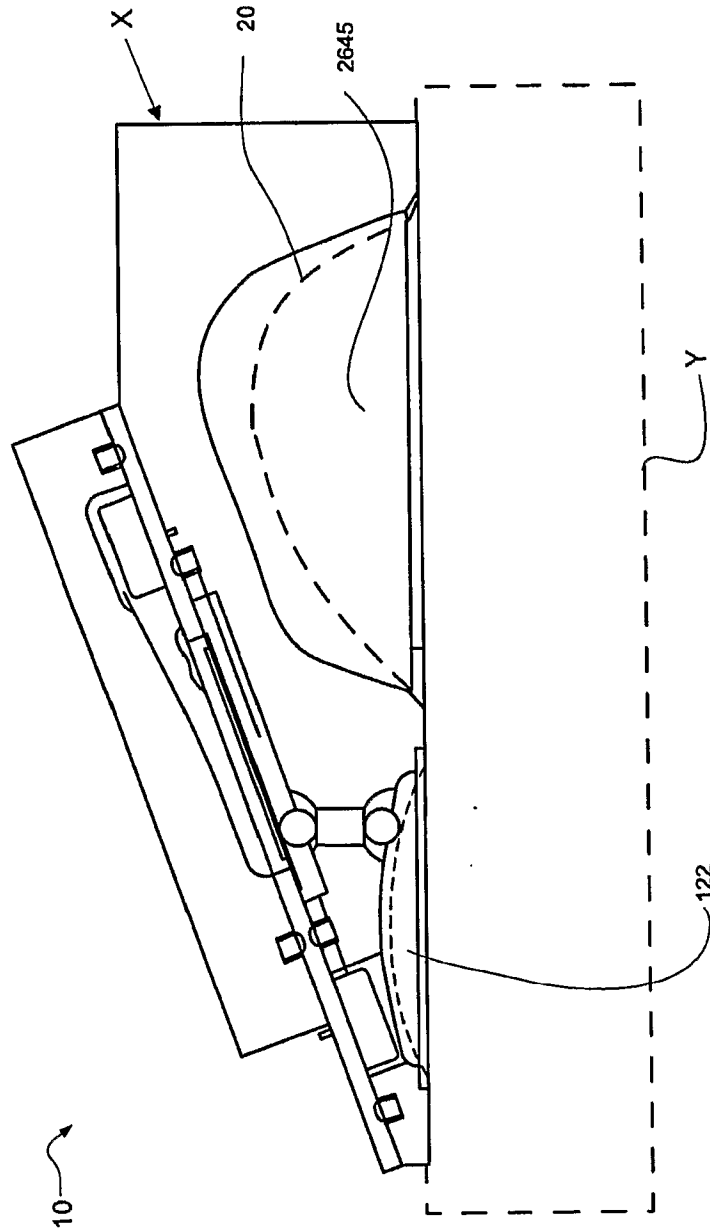

FIG. 72

+

+

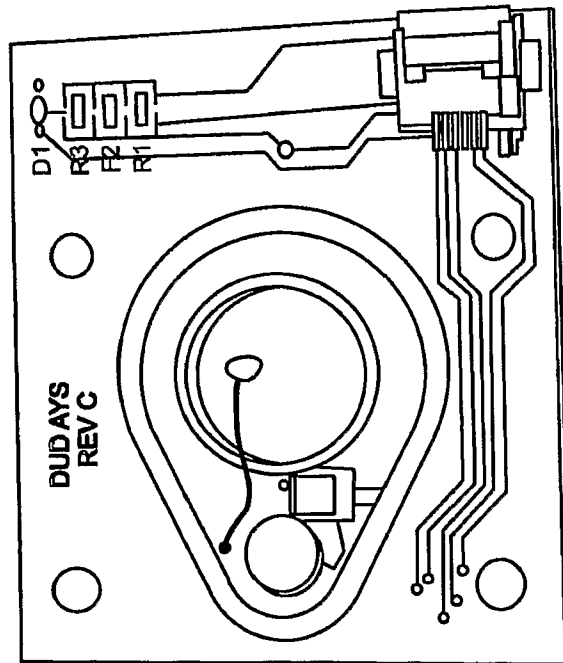

FIG. 73

+

+

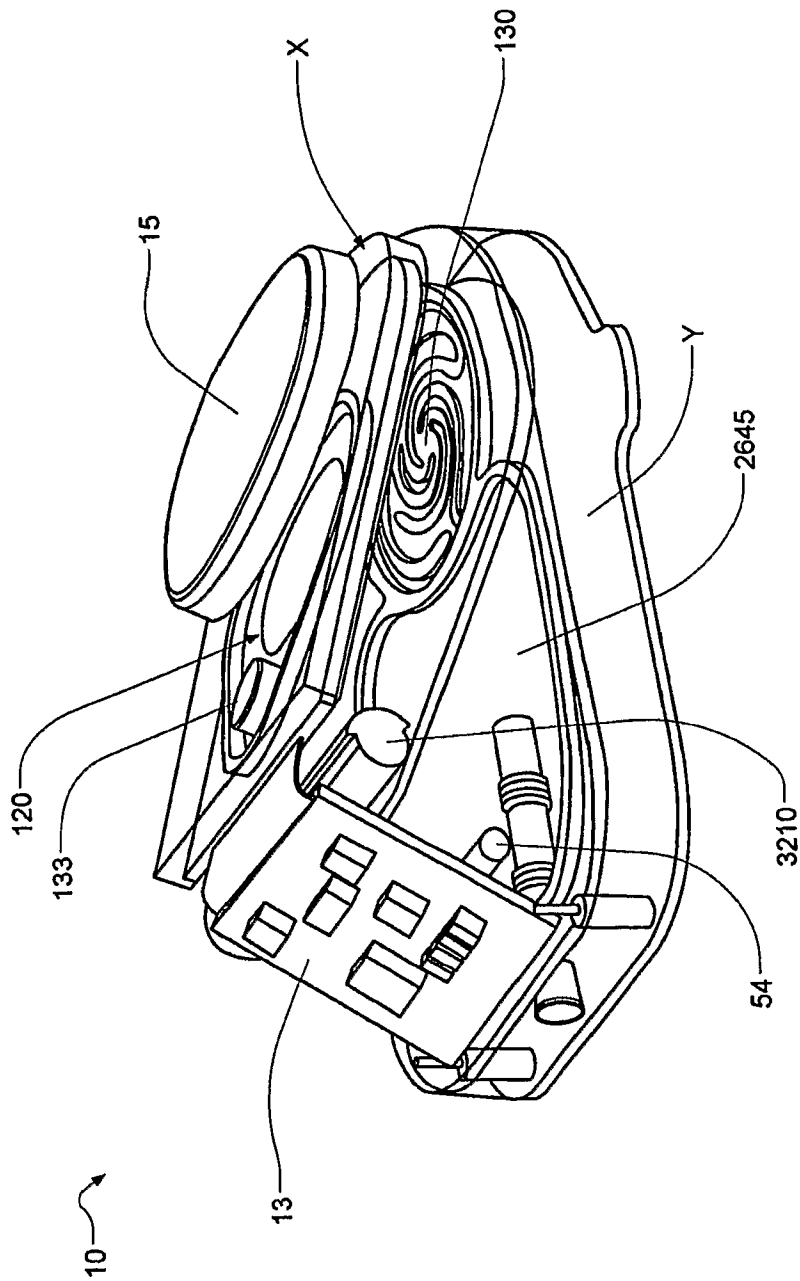

FIG. 74

+



+

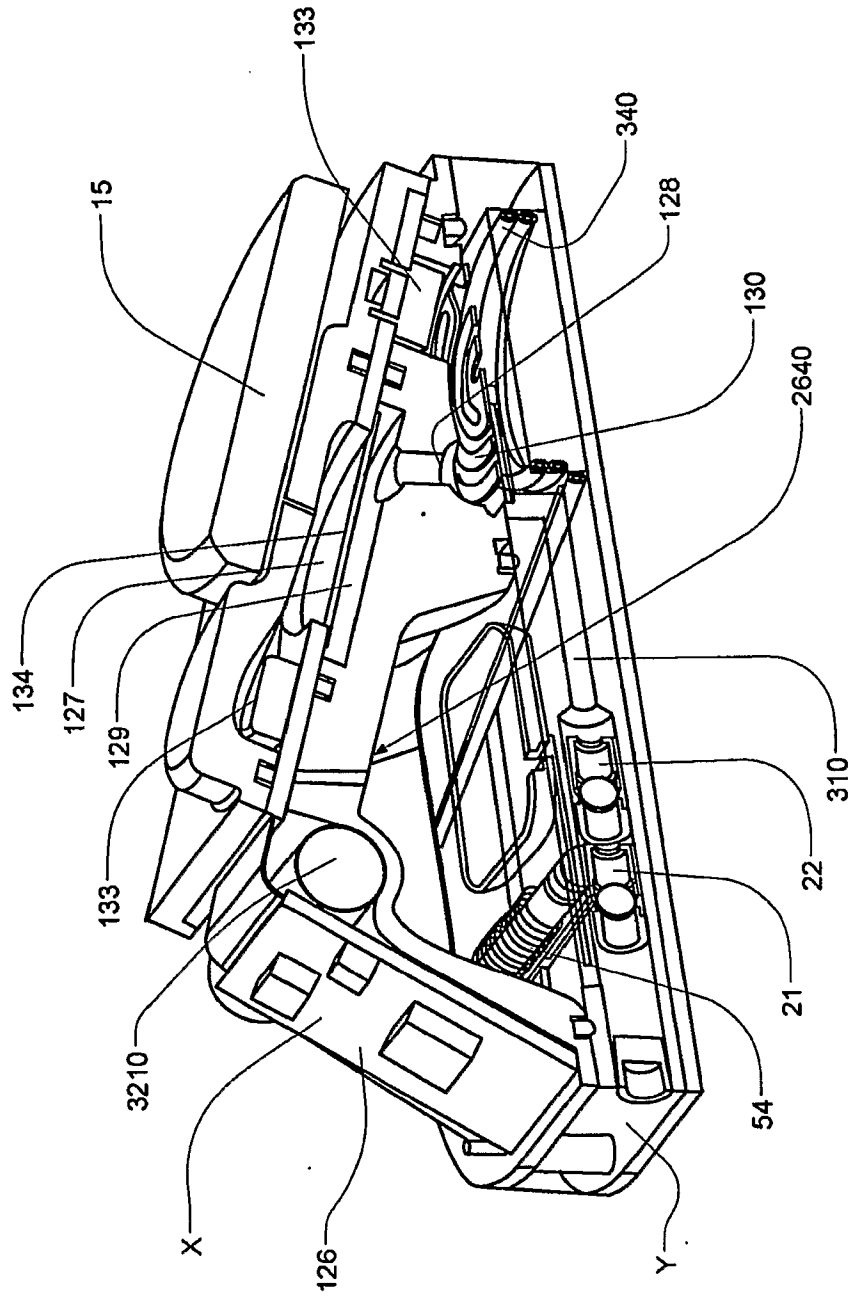

FIG. 75

+

+

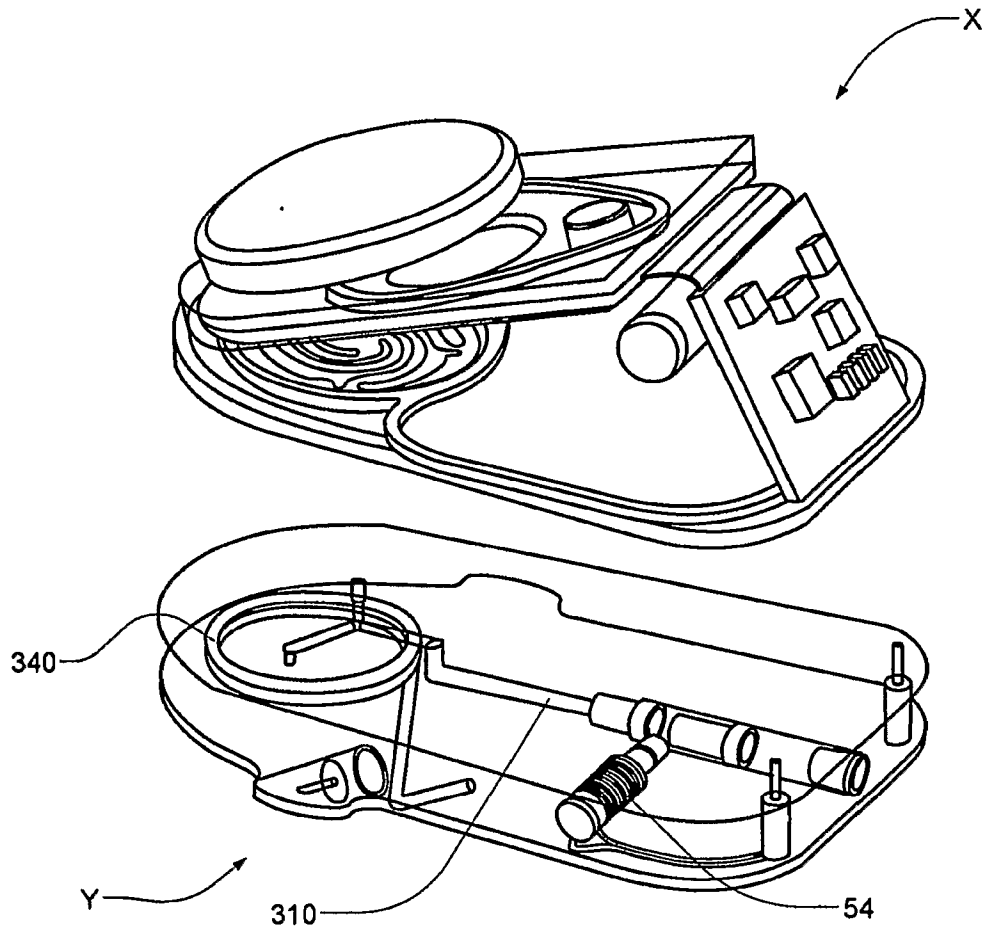

FIG. 76

+

+

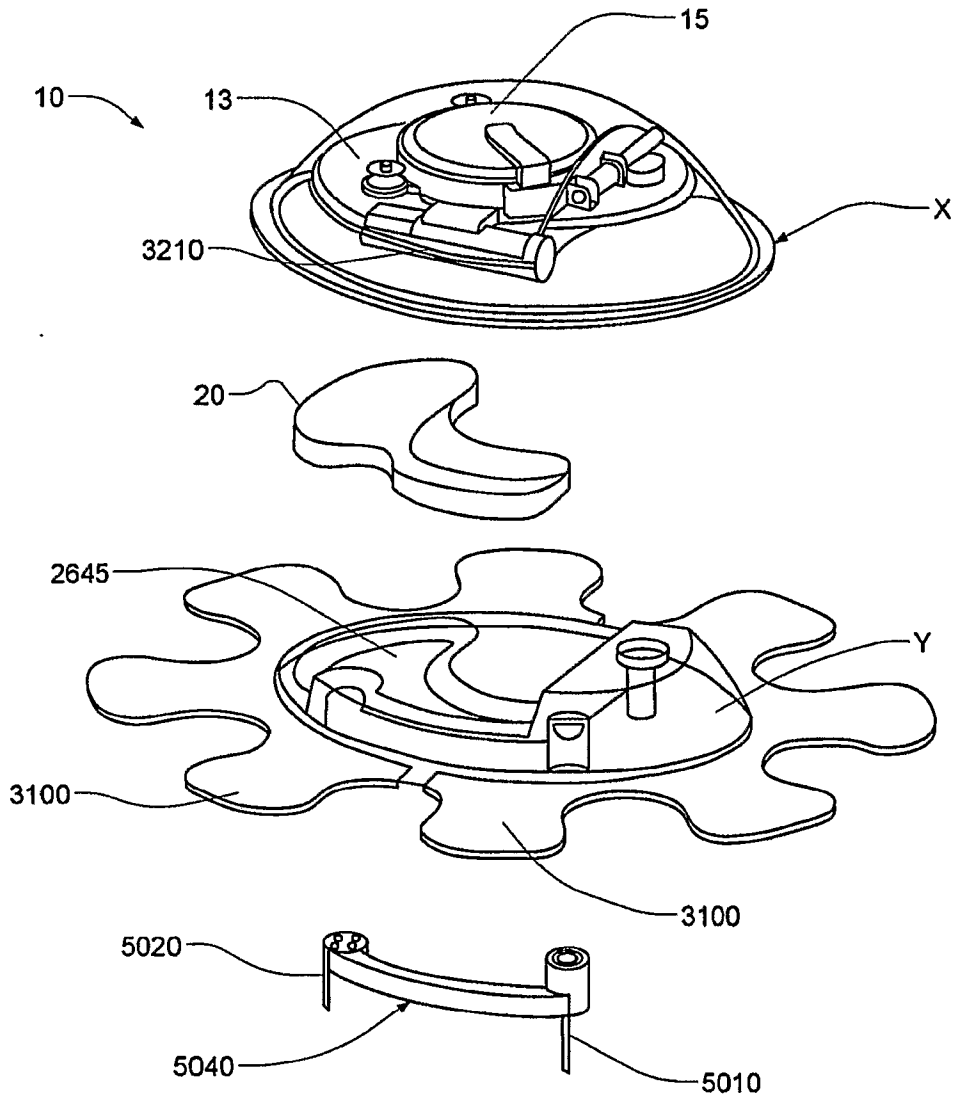

FIG. 77

+

SUBSTITUTE SHEET (RULE 26)

SUBSTITUTE SHEET (RULE 26)

+

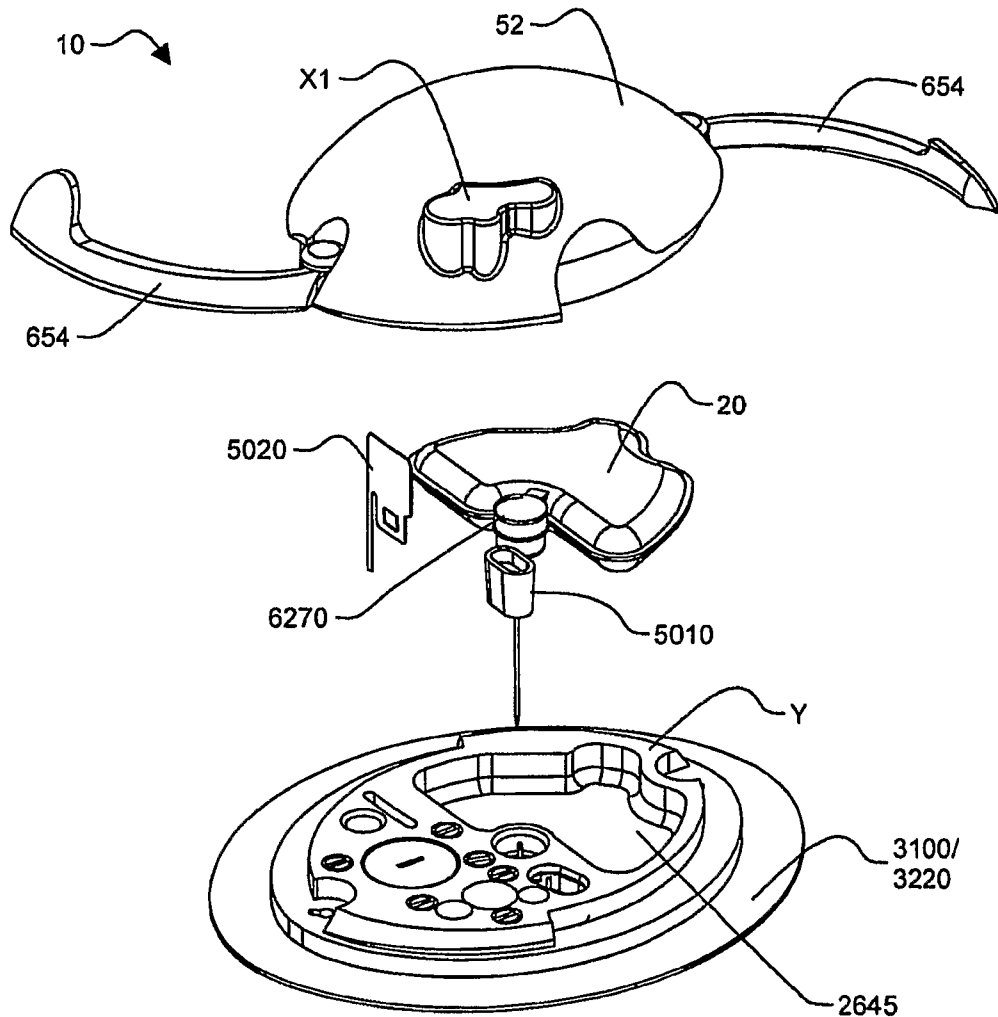

FIG. 78

+

+

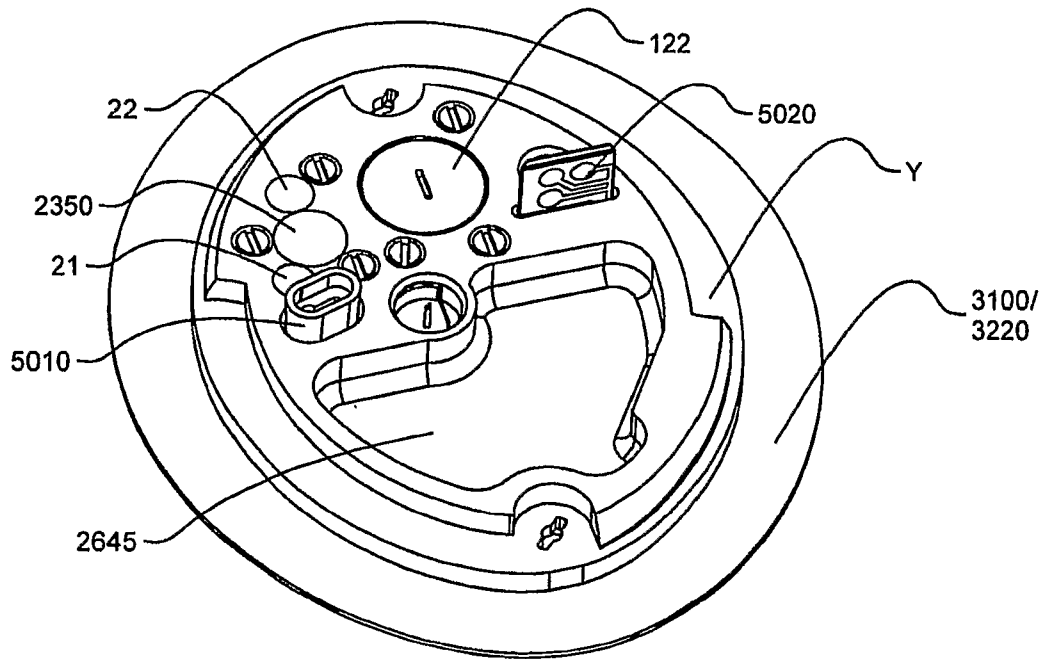

FIG. 79

+

**SUBSTITUTE SHEET (RULE 26)**

**SUBSTITUTE SHEET (RULE 26)**

+

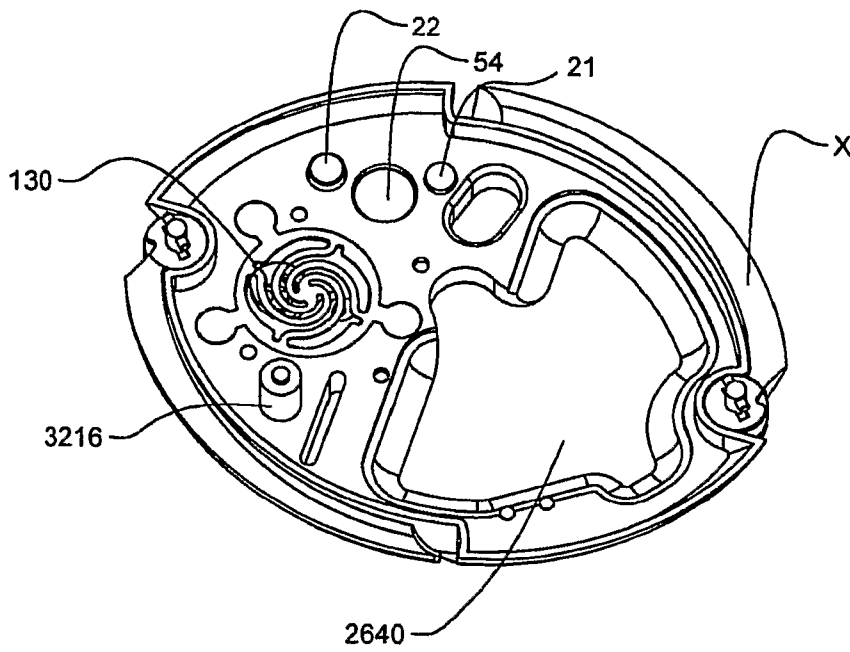

FIG. 80

+

**SUBSTITUTE SHEET (RULE 26)**

**SUBSTITUTE SHEET (RULE 26)**

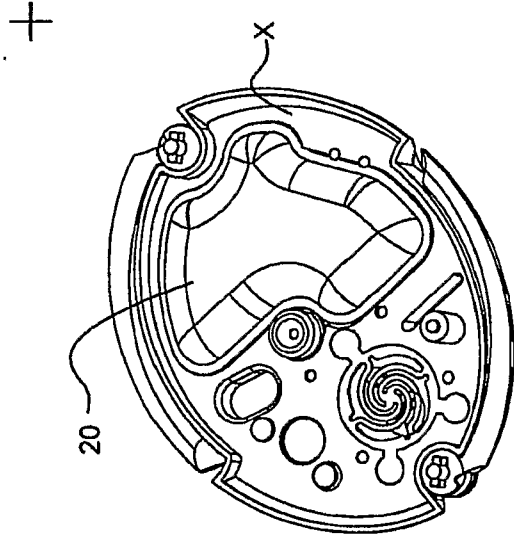

FIG. 81B

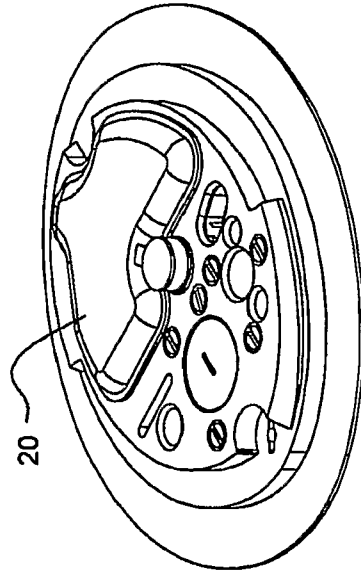

FIG. 81C

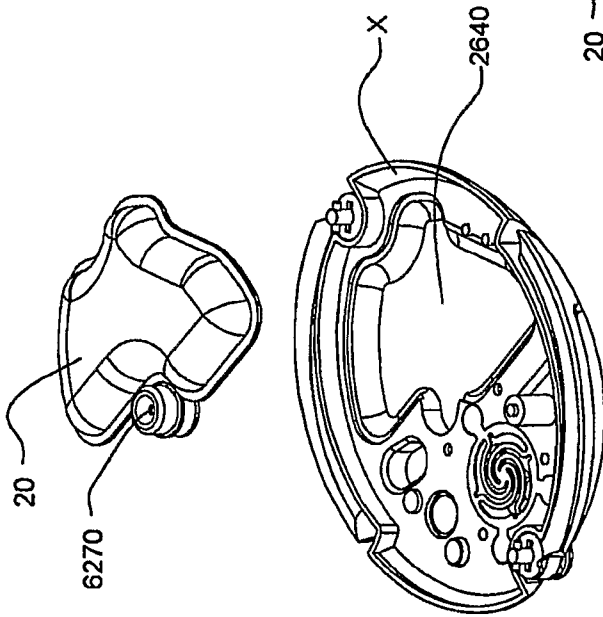

FIG. 81A

SUBSTITUTE SHEET (RULE 26)

SUBSTITUTE SHEET (RULE 26)

+

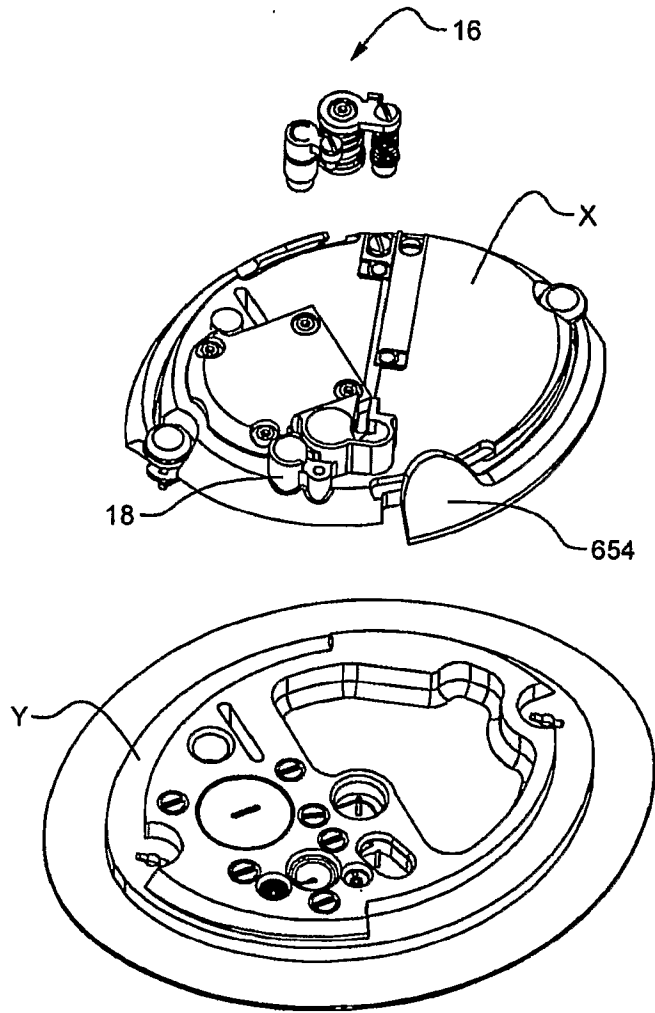

FIG. 82

+



+

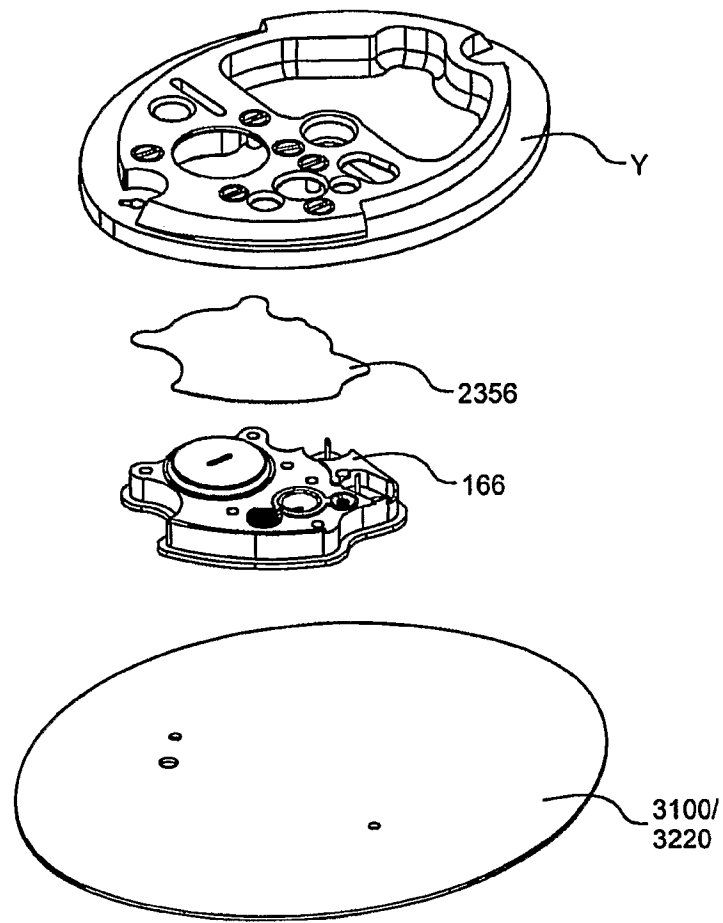

FIG. 83

+

+

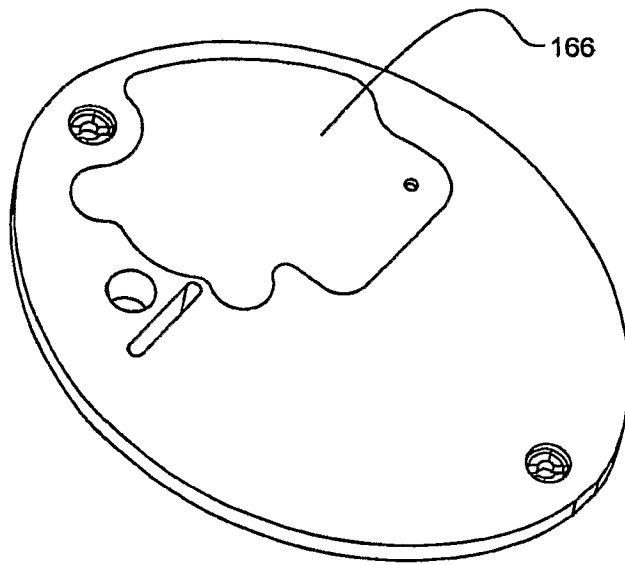

FIG. 84

+

+

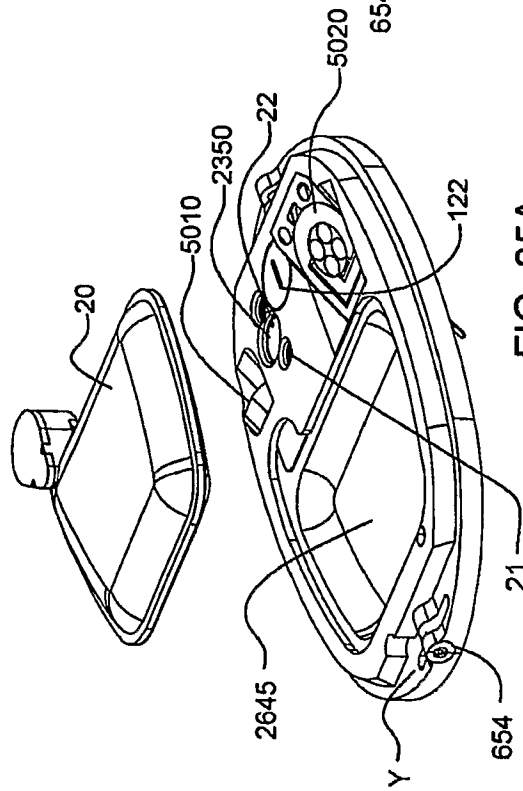
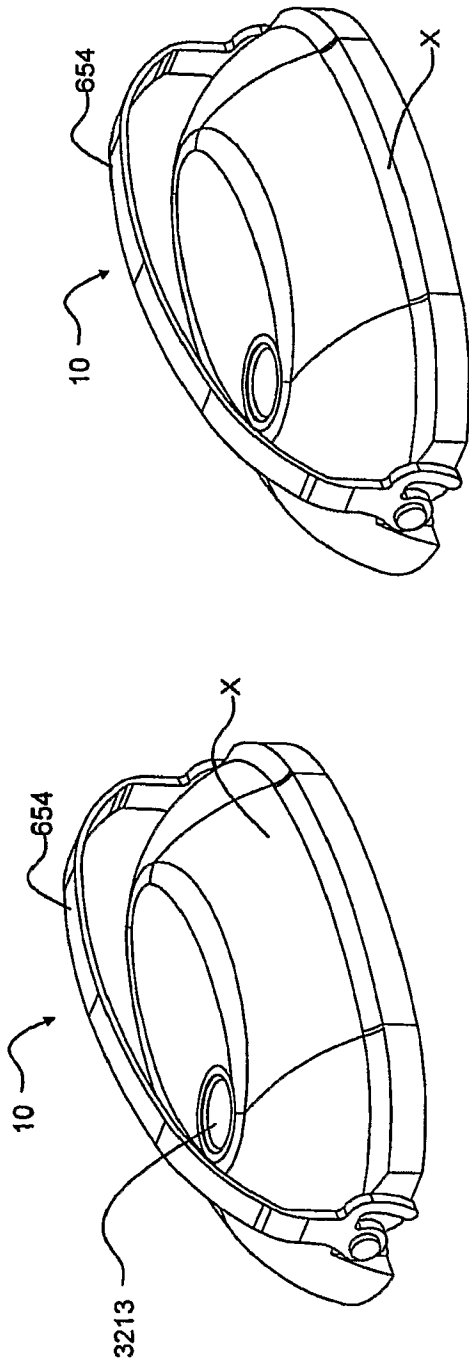

FIG. 85B

FIG. 85A

+

+

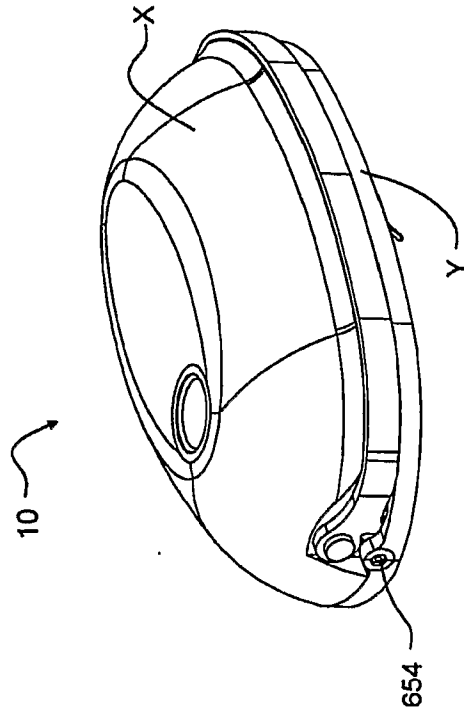

FIG. 85D

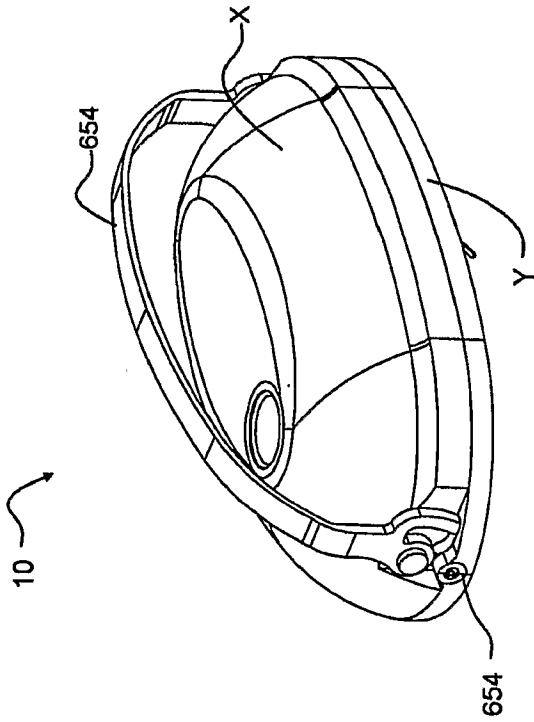

FIG. 85C

+

+

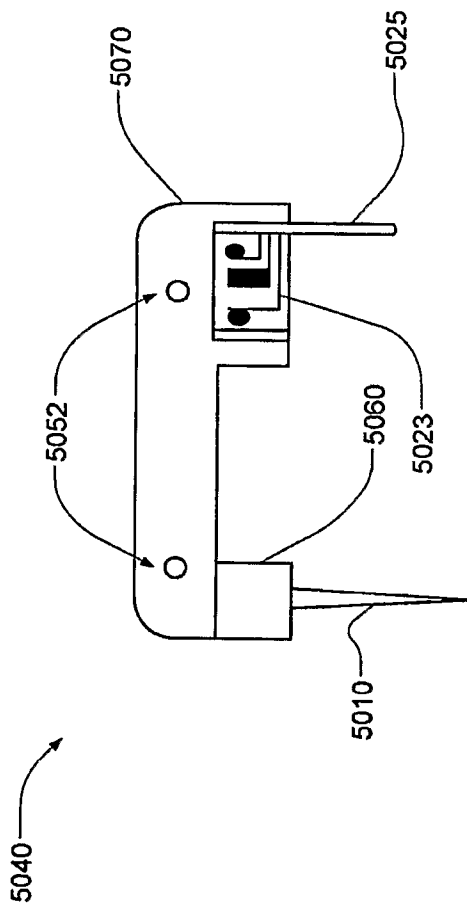

FIG. 86A

+

+

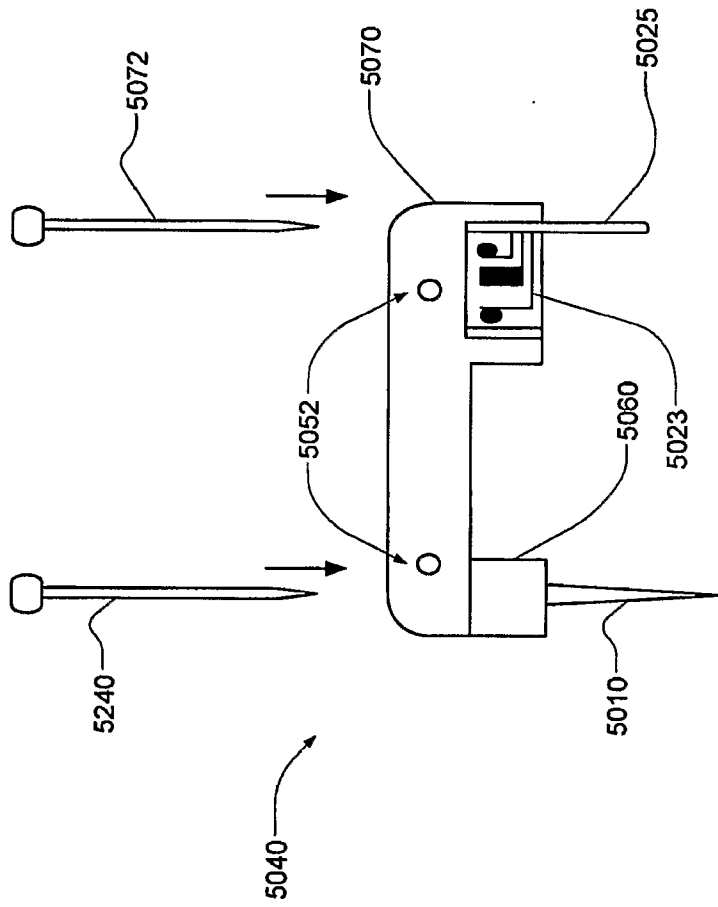
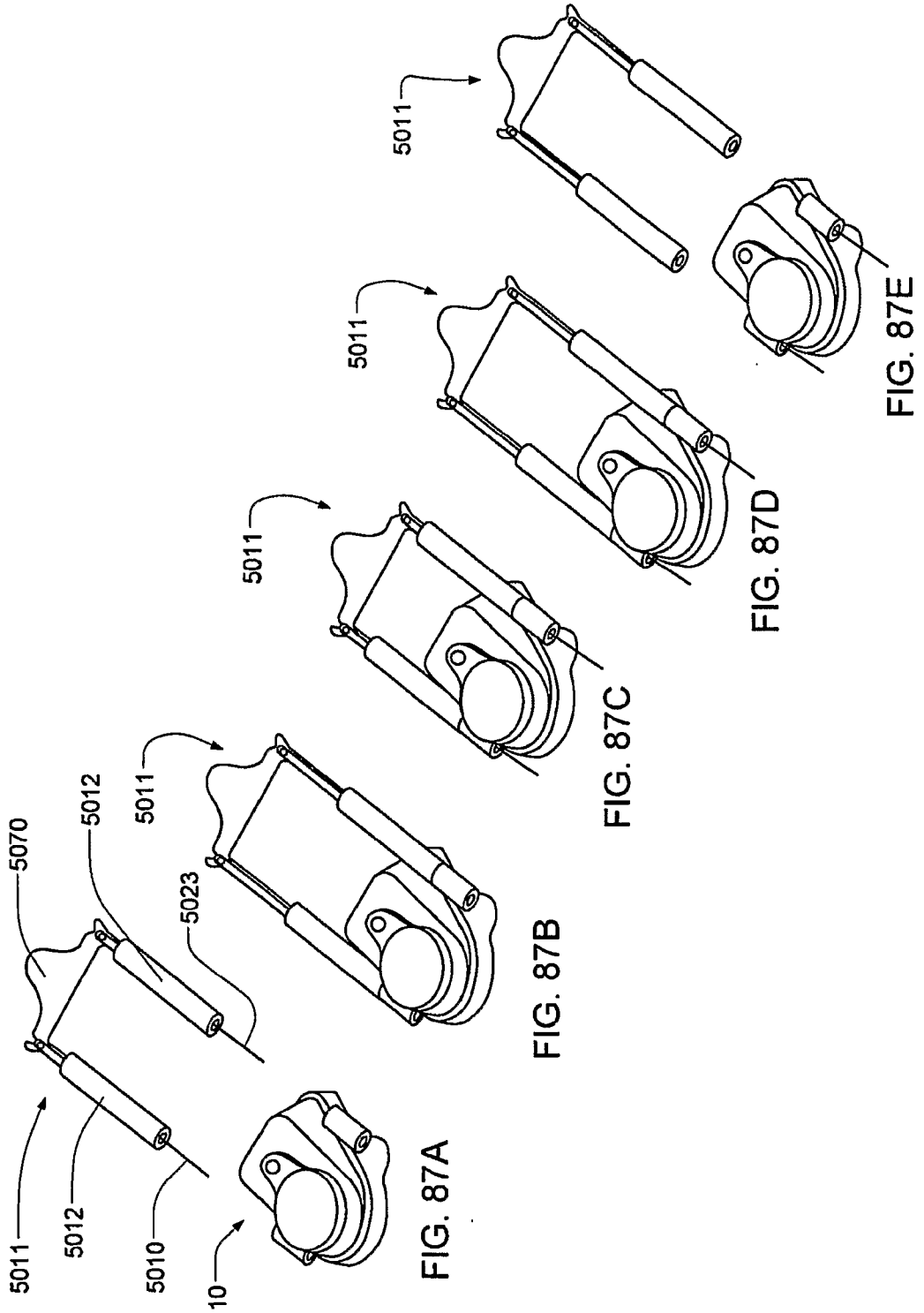

FIG. 86B

+

+



+

+

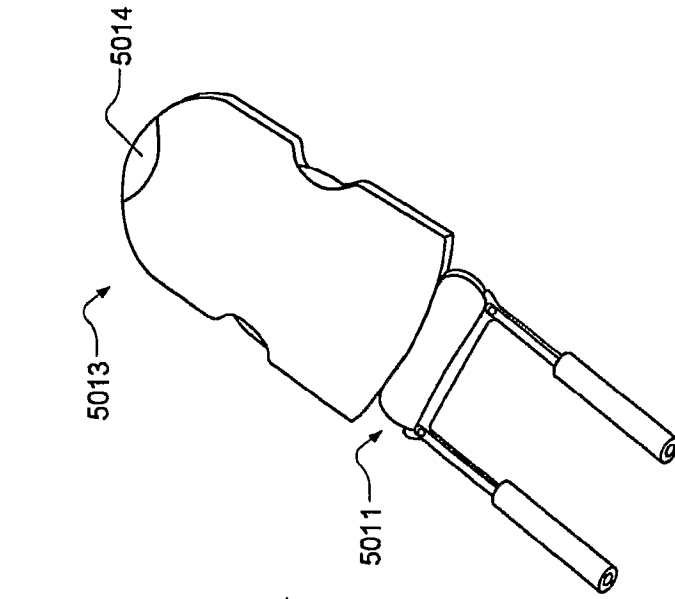

FIG. 88B

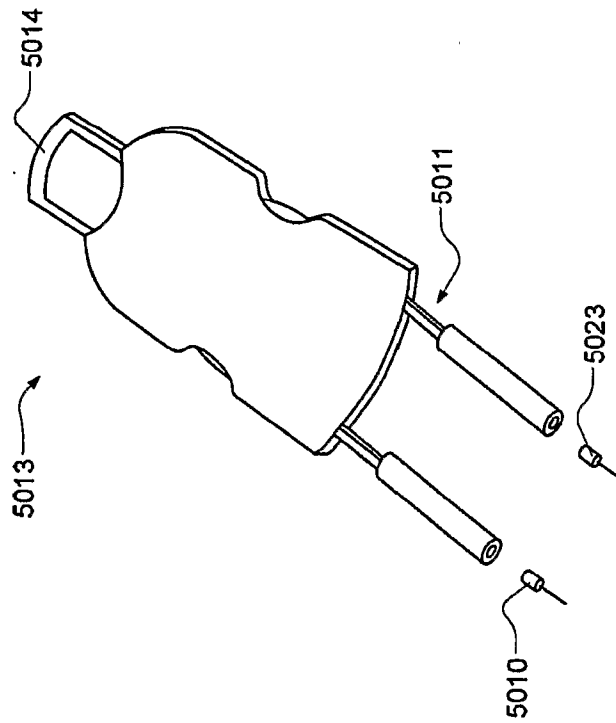

FIG. 88A

+



+

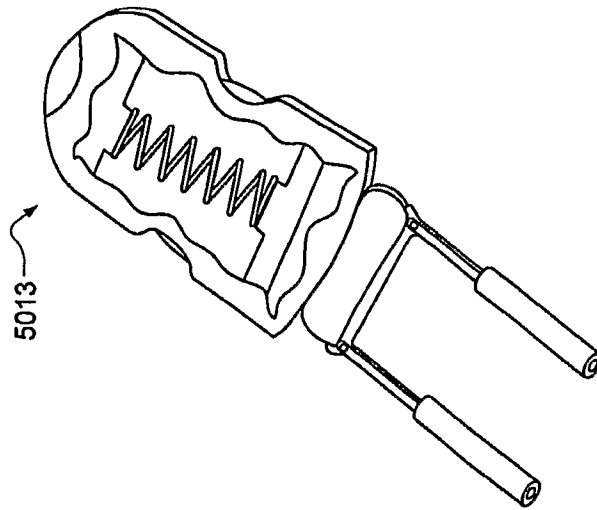

FIG. 88D

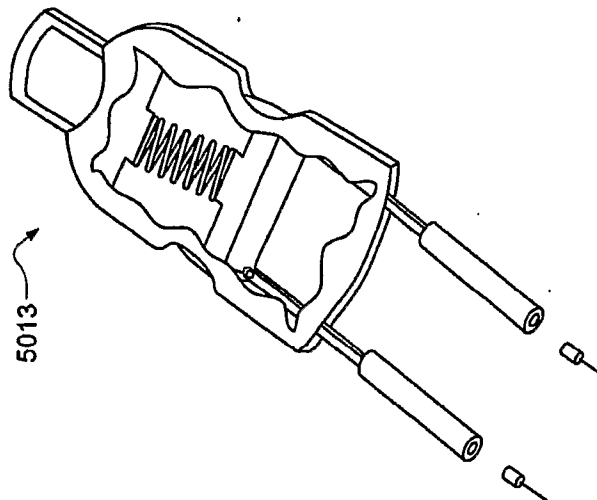

FIG. 88C

+

+

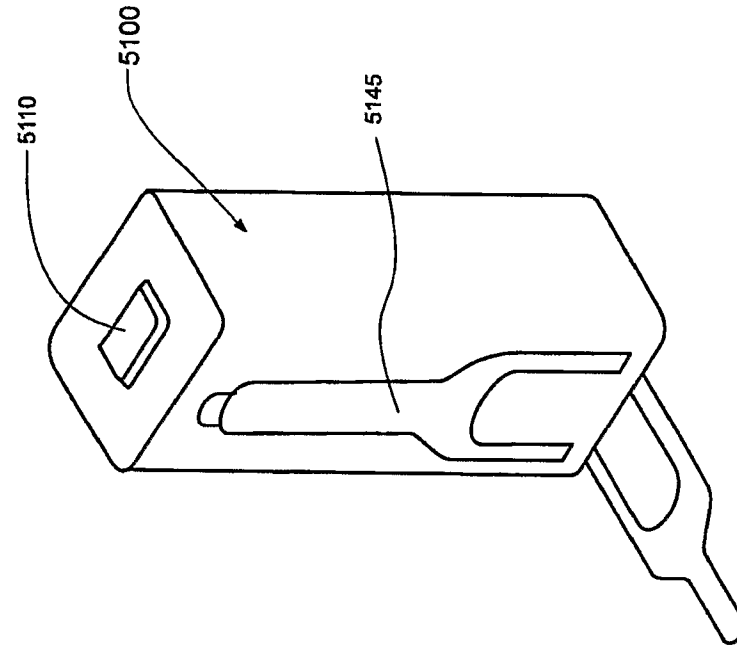

FIG. 89B

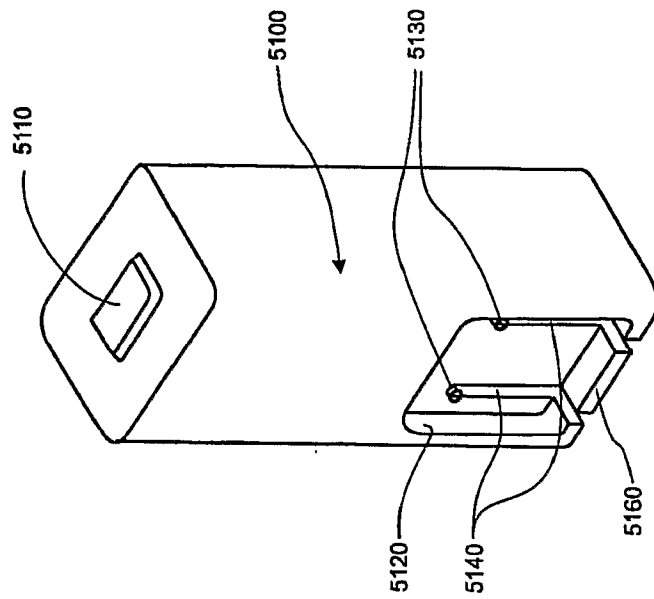

FIG. 89A

+

+

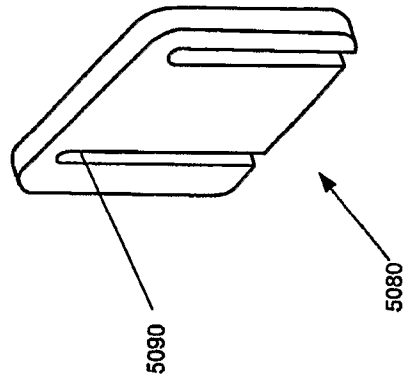

FIG. 90

+

+

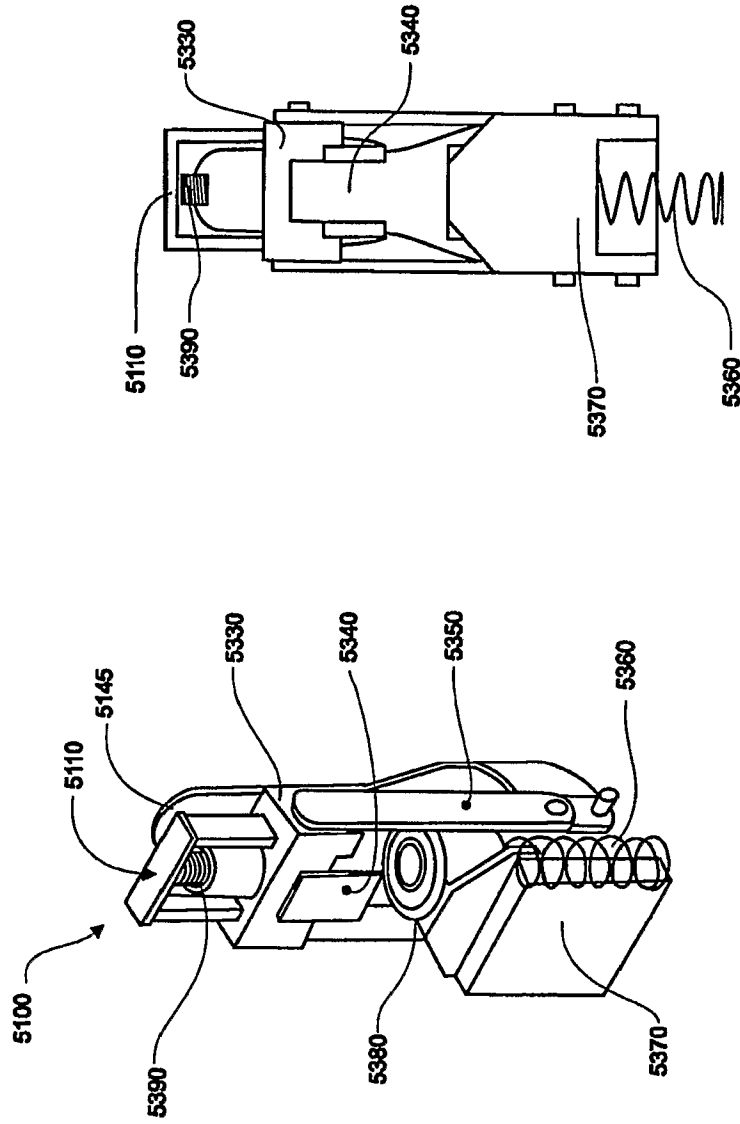

FIG. 91A

FIG. 91B

+

+

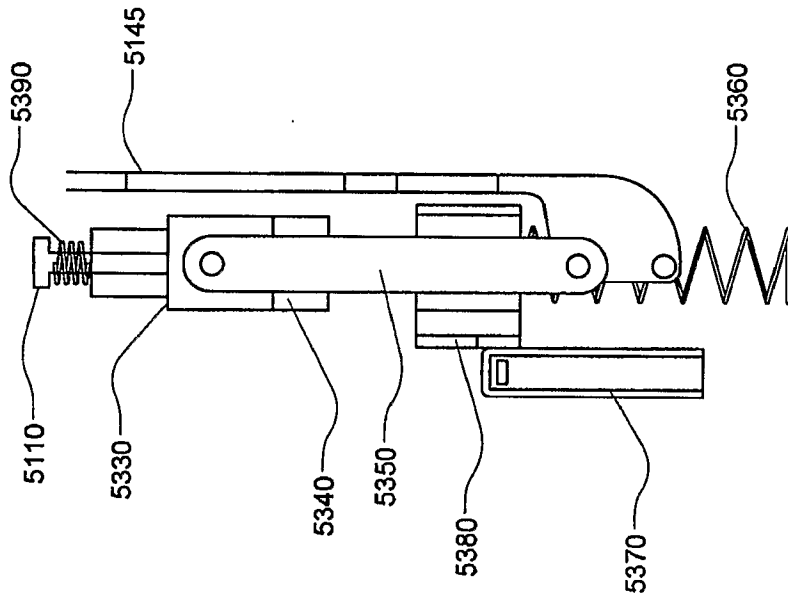

FIG. 91C

+

+

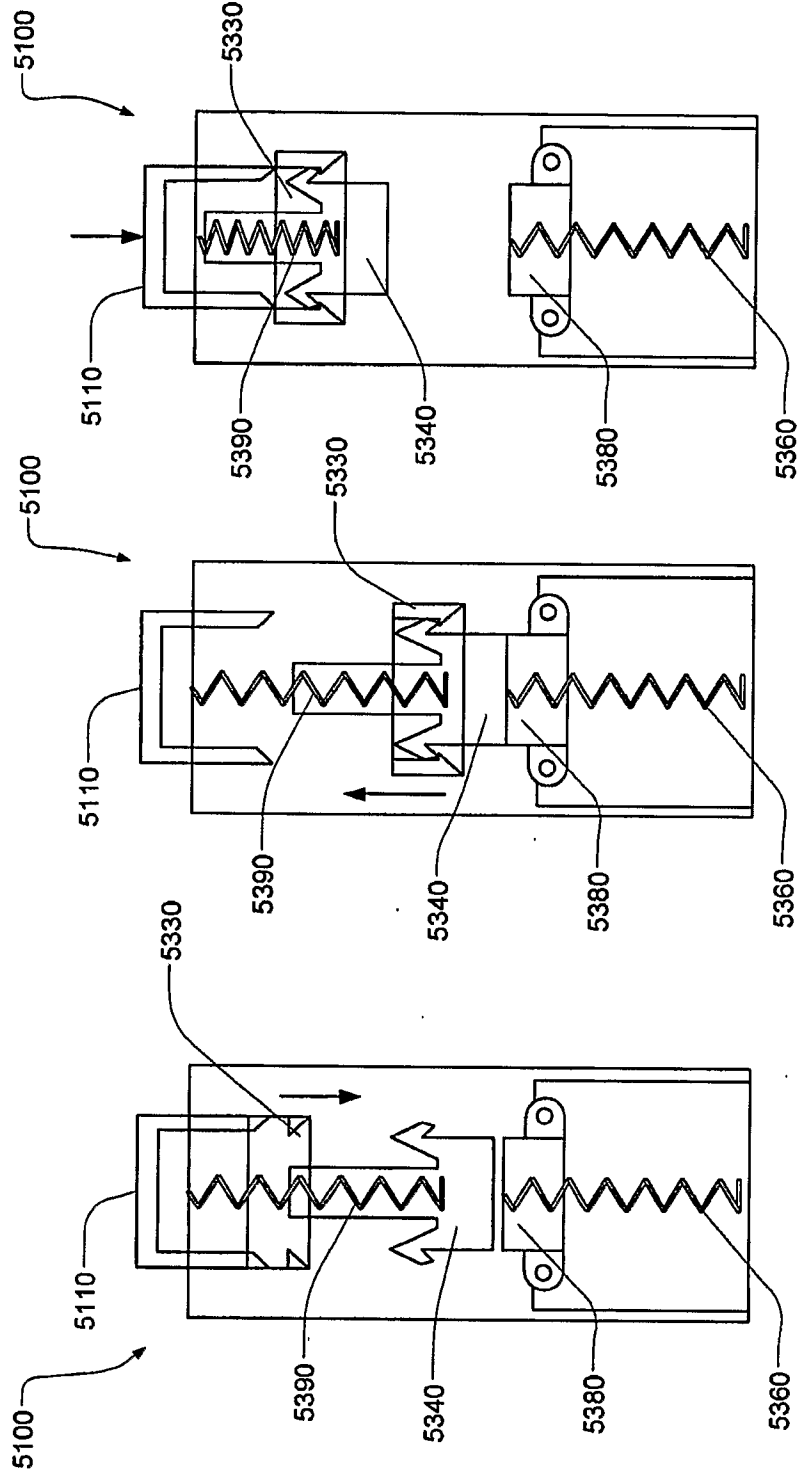

FIG. 92A

FIG. 92B

FIG. 92C

+

+

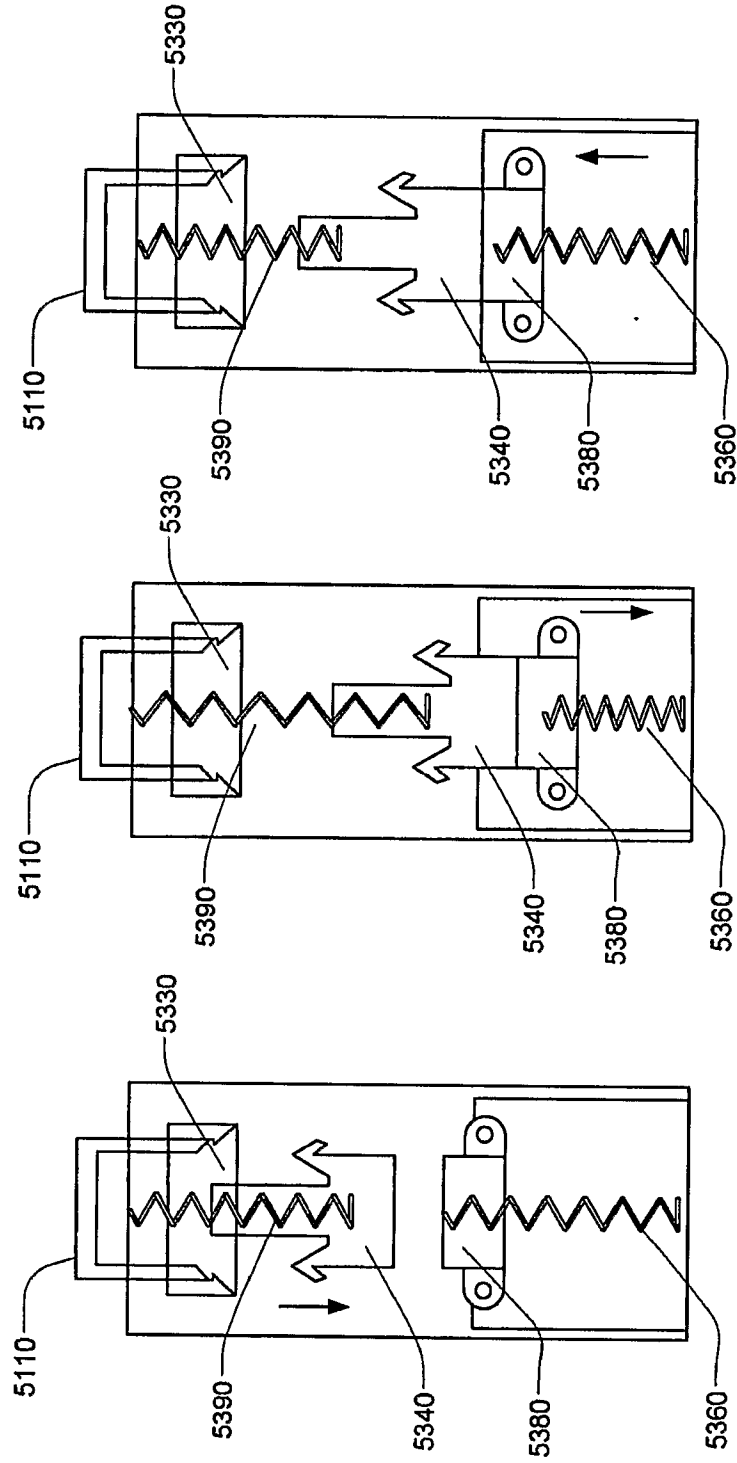

FIG. 92F

FIG. 92E

FIG. 92D

+

+

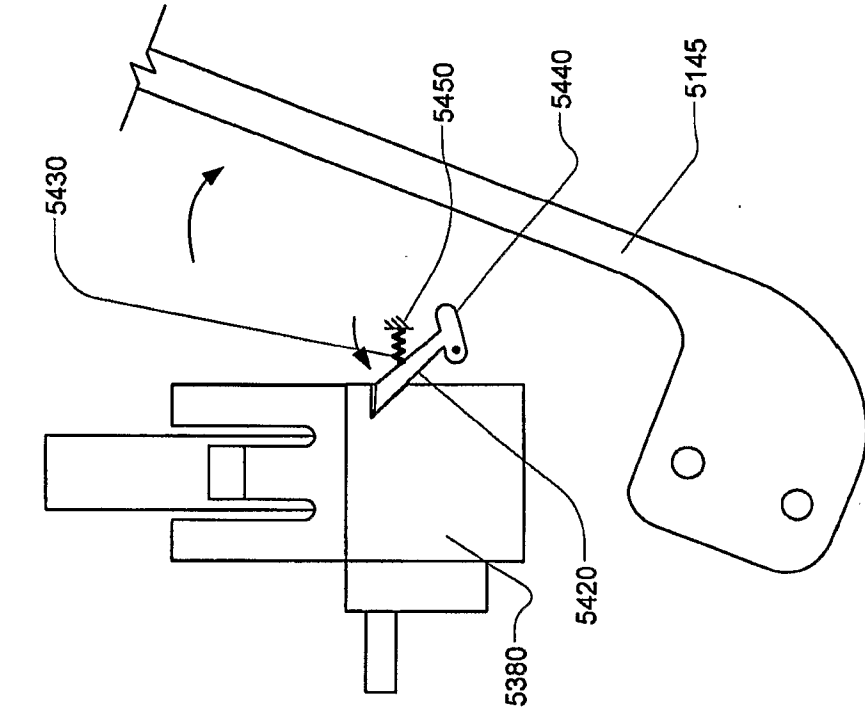

FIG. 92H

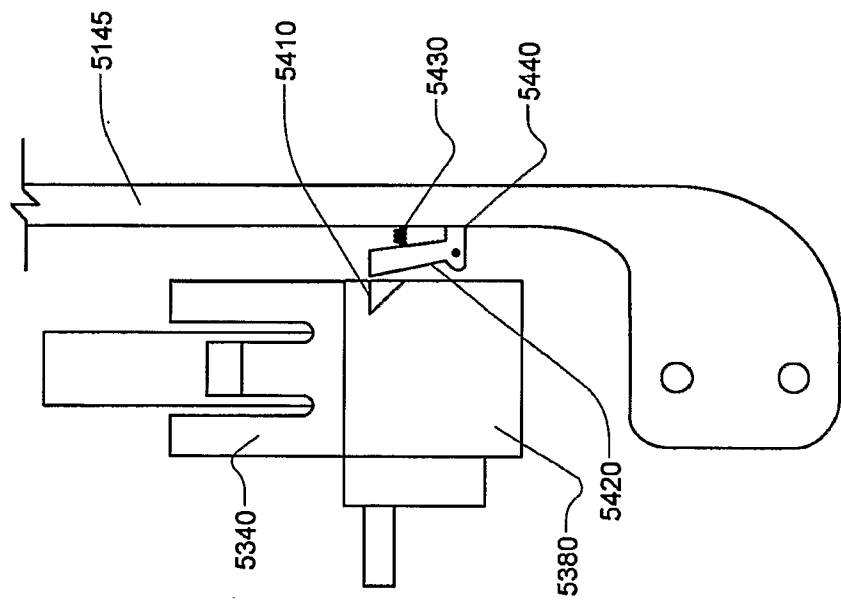

FIG. 92G

+



+

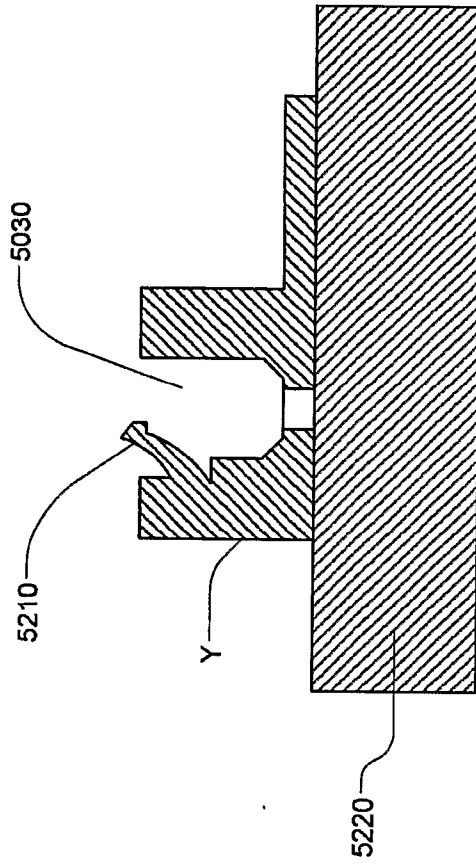

FIG. 93A

+

+

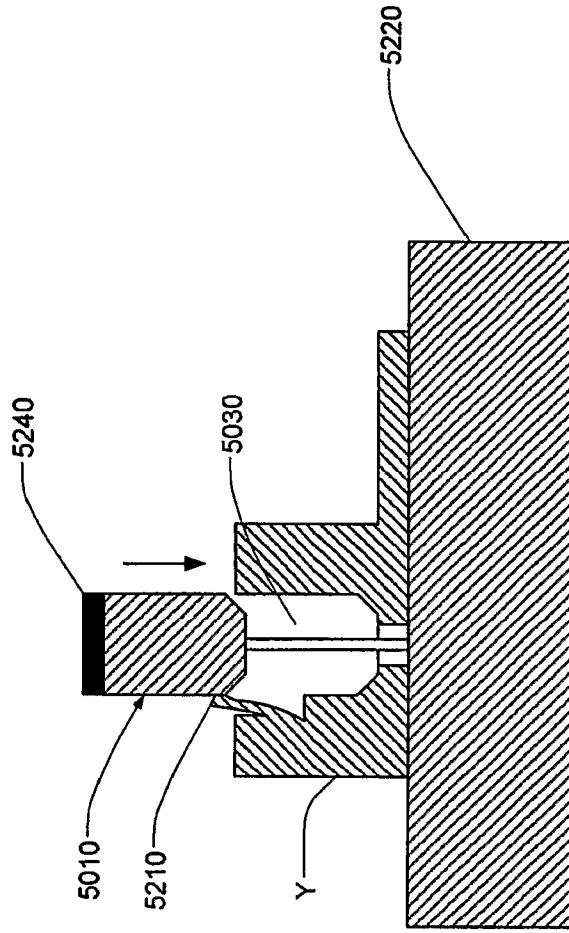

FIG. 93B

+

+

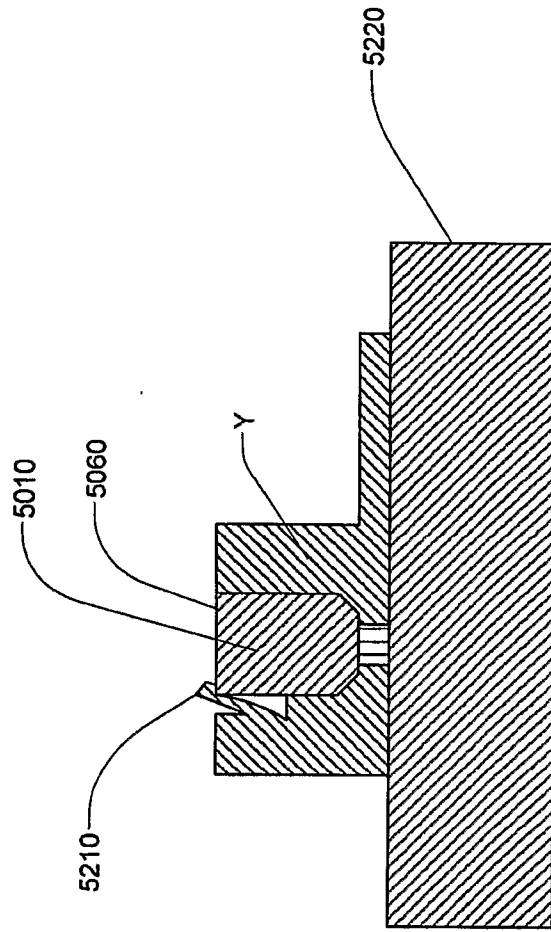

FIG. 93C

+

+

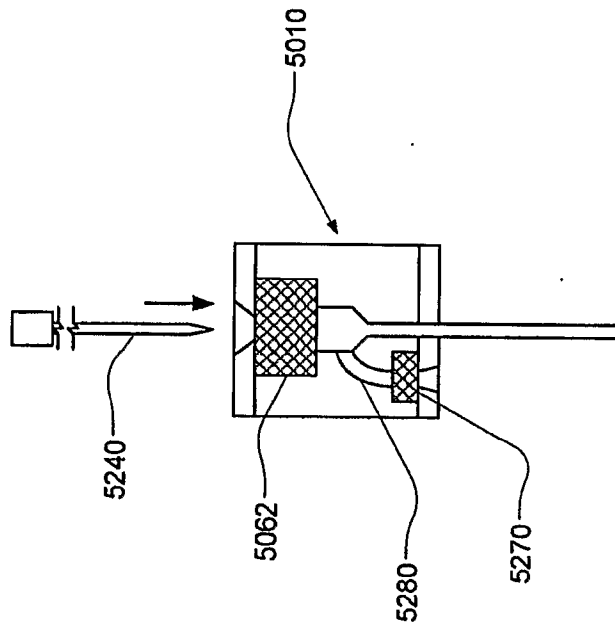

FIG. 94A

+

+

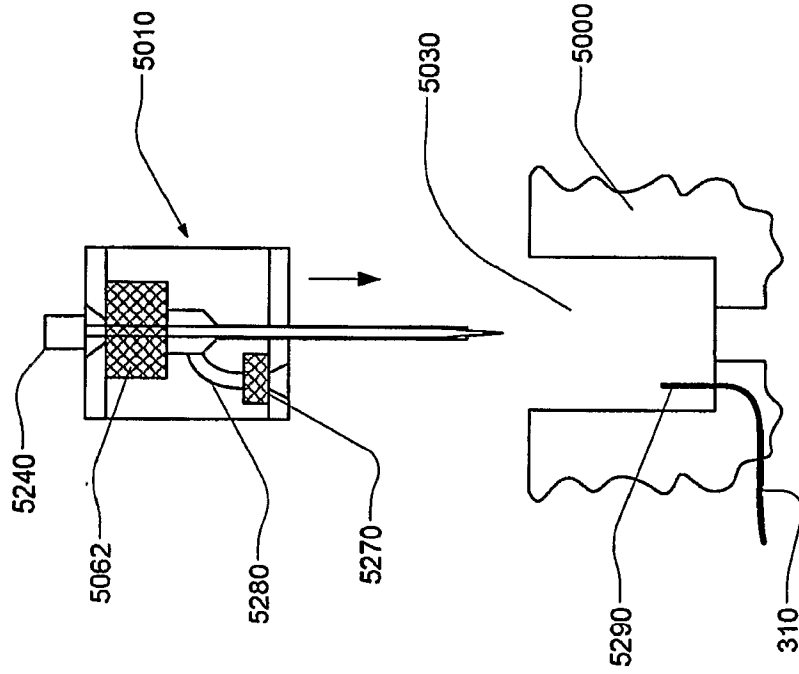

FIG. 94B

+

+

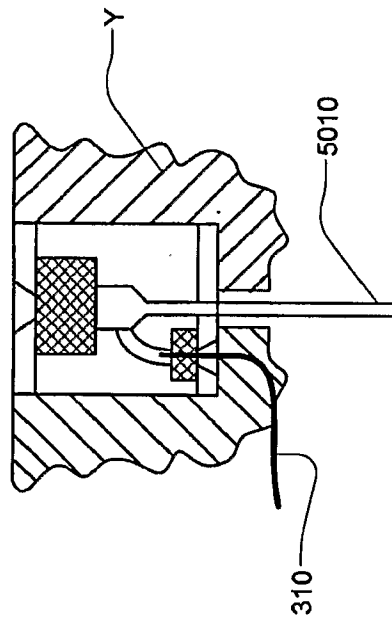

FIG. 94C

+

+

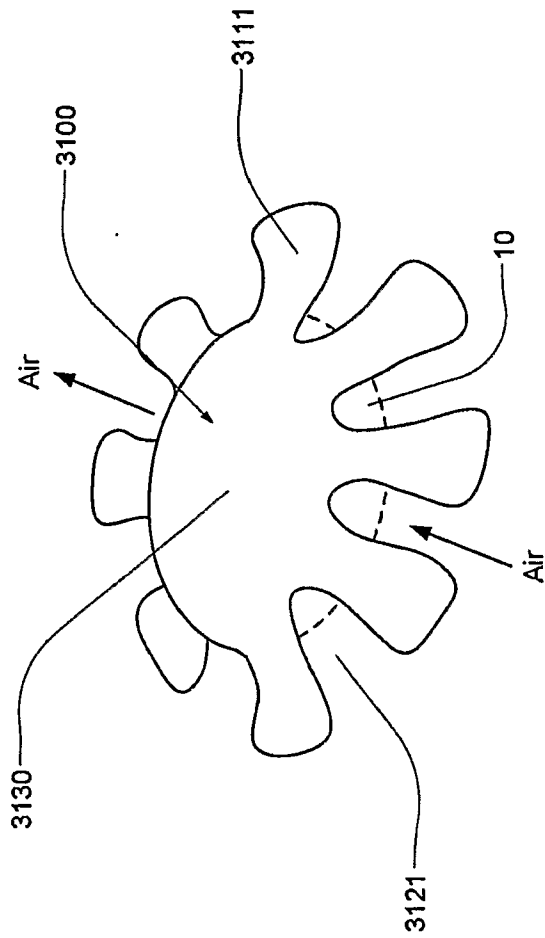

FIG. 95

+

+

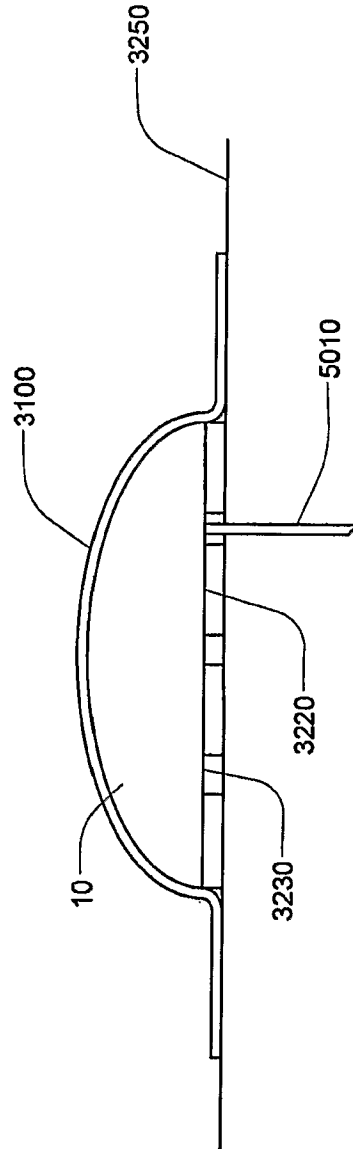

FIG. 96

+



+

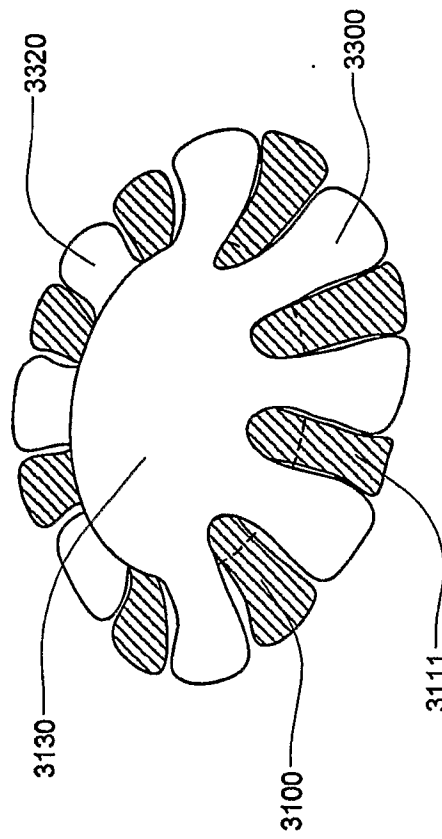

FIG. 97

+

+

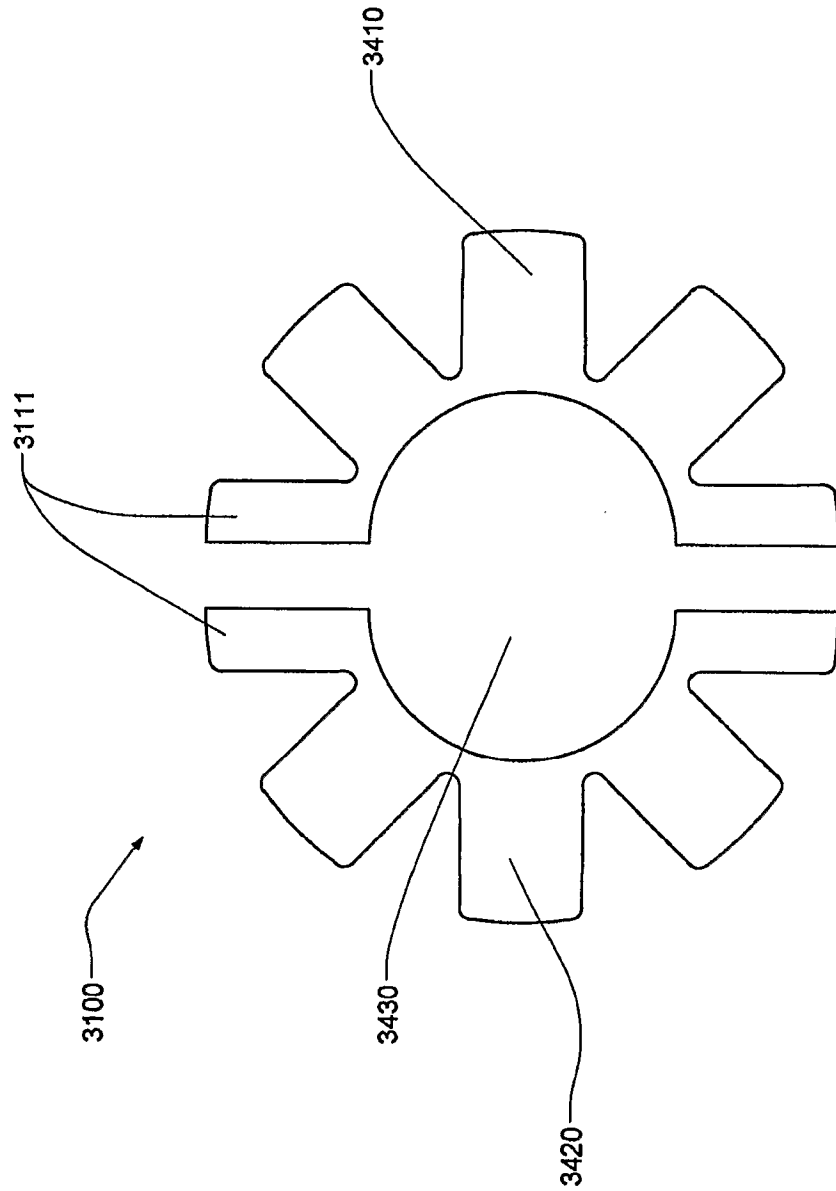

FIG. 98

+

+

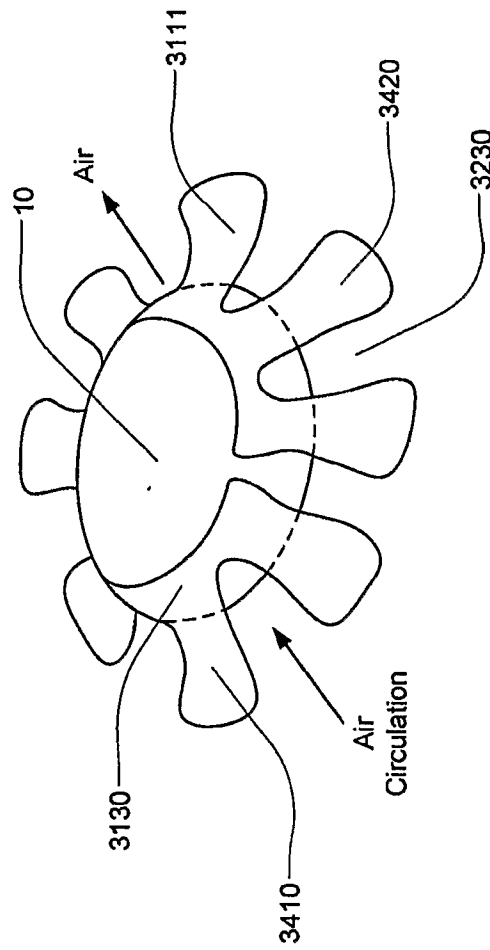

FIG. 99

+

+

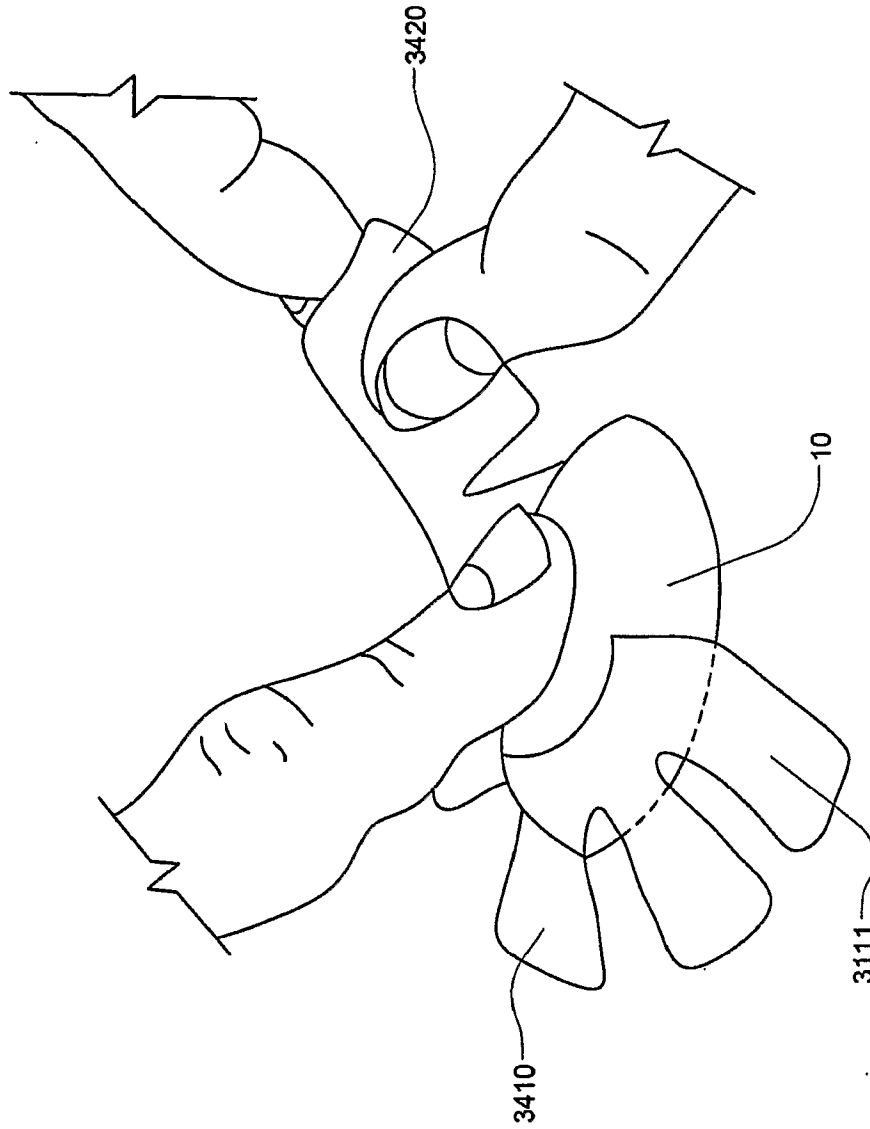

FIG. 100

+

+

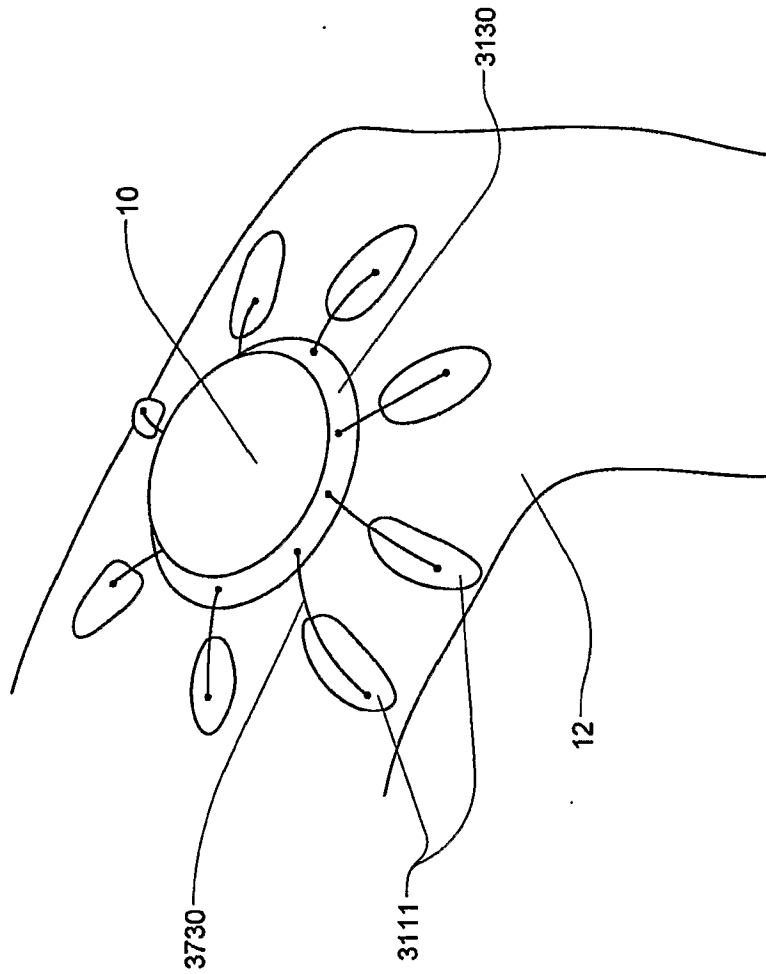

FIG. 101

+

+

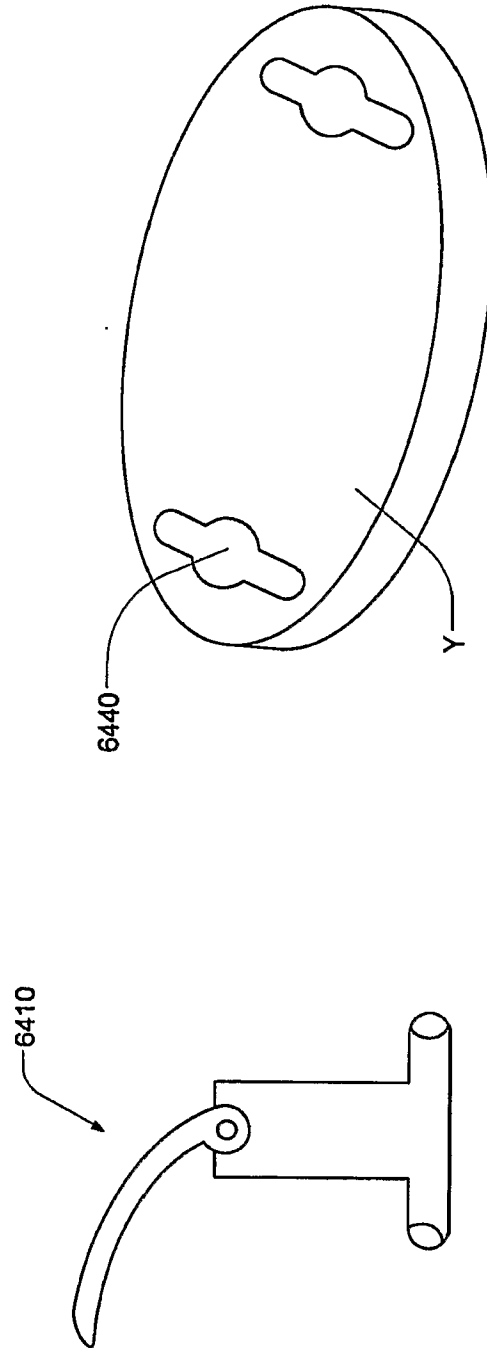

FIG. 102B

FIG. 102A

+

+

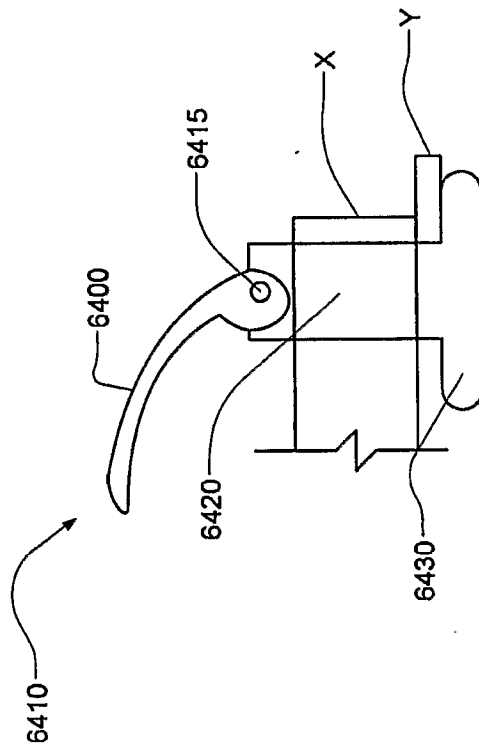

FIG. 102C

+

+

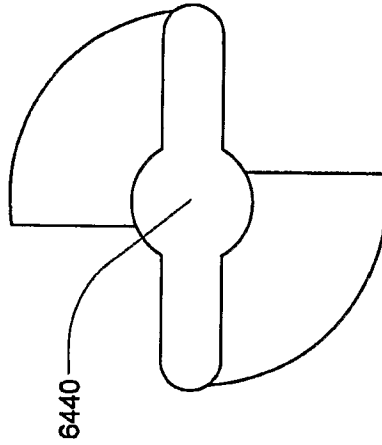

FIG. 103B

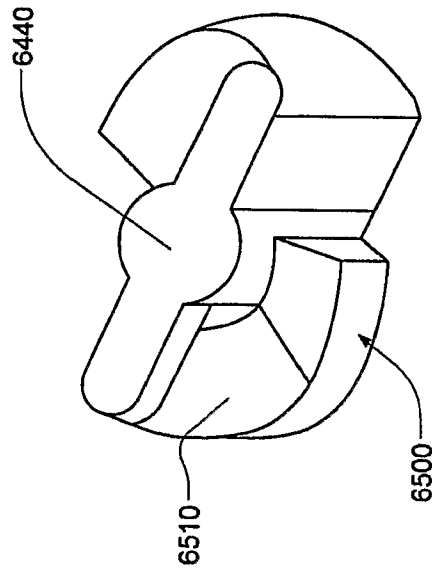

FIG. 103A

+



+

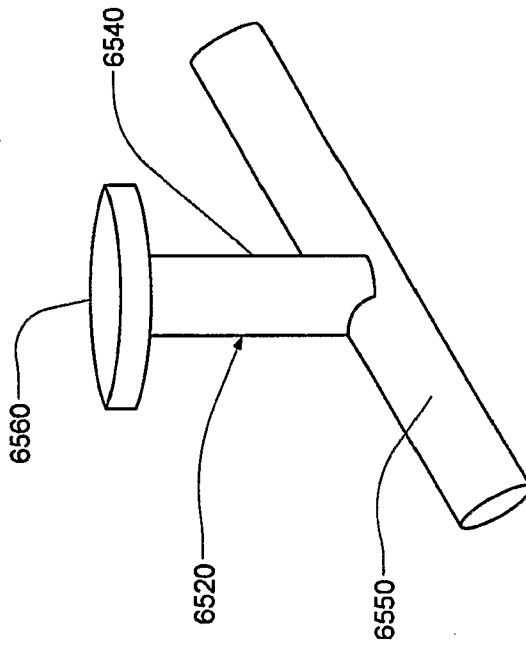

FIG. 103C

+

+

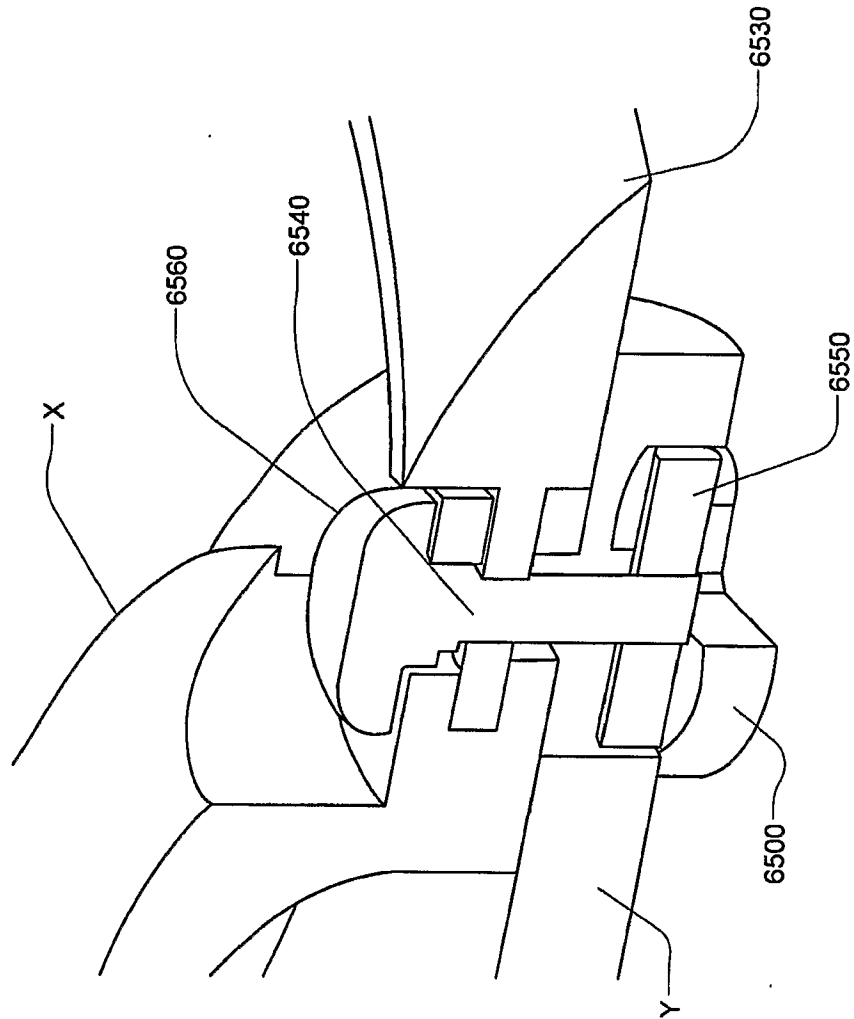

FIG. 103D

+

+

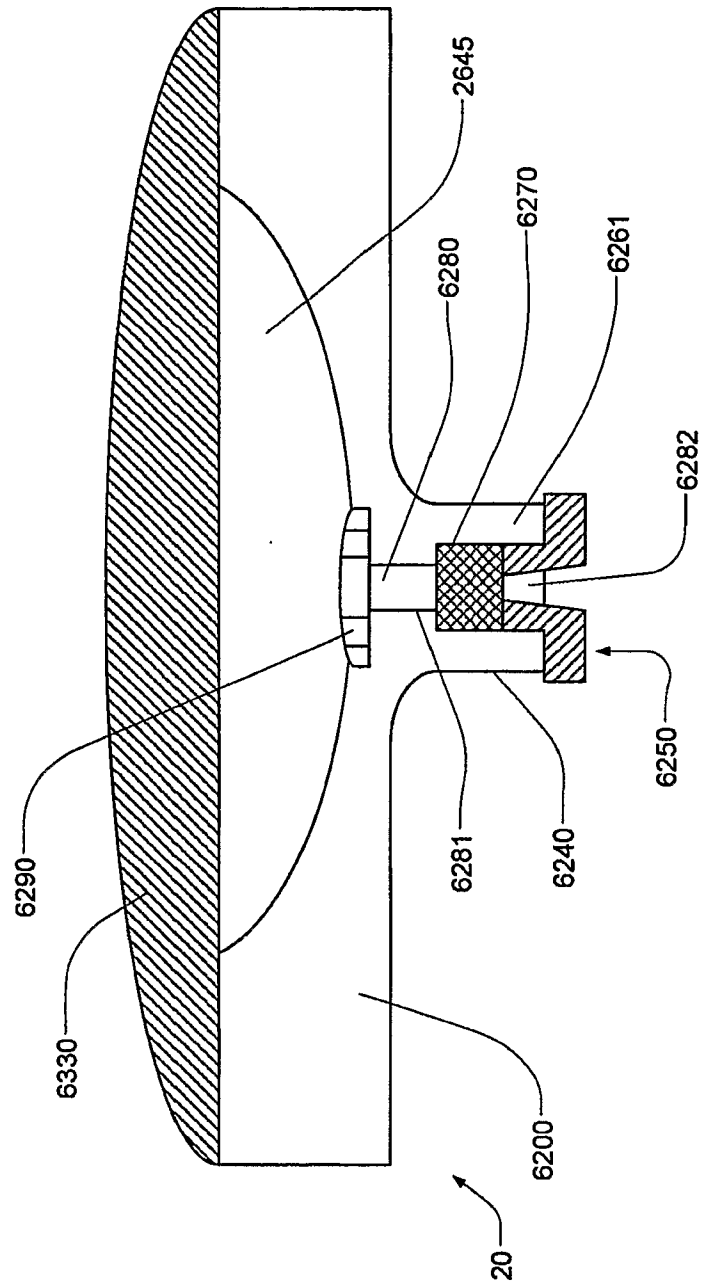

FIG. 104

+

+

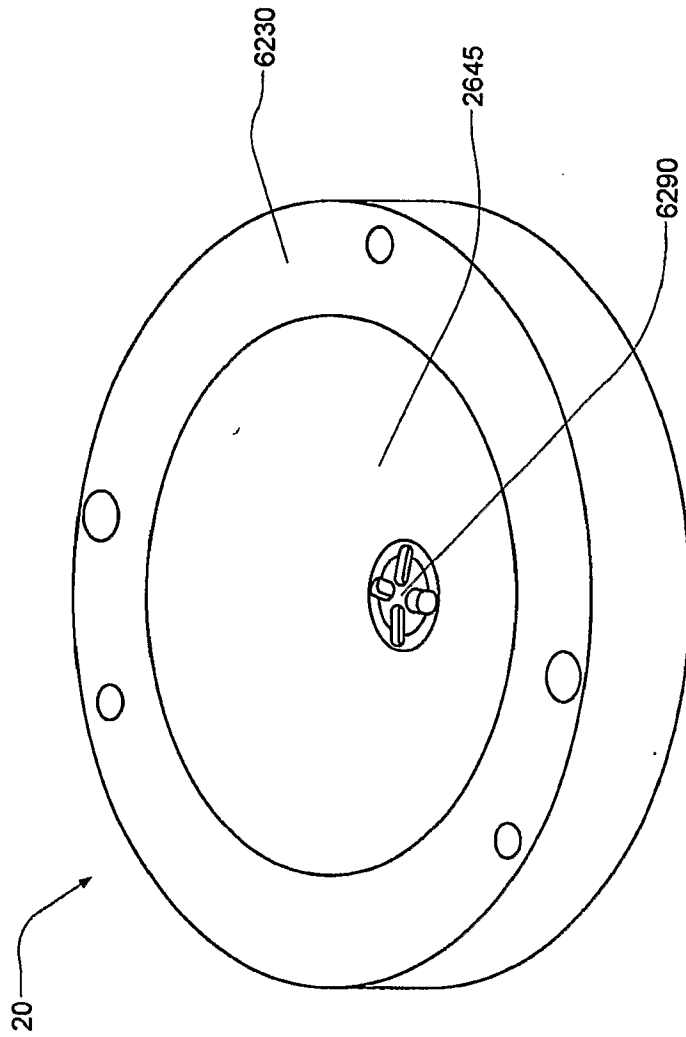

FIG. 105

+

+

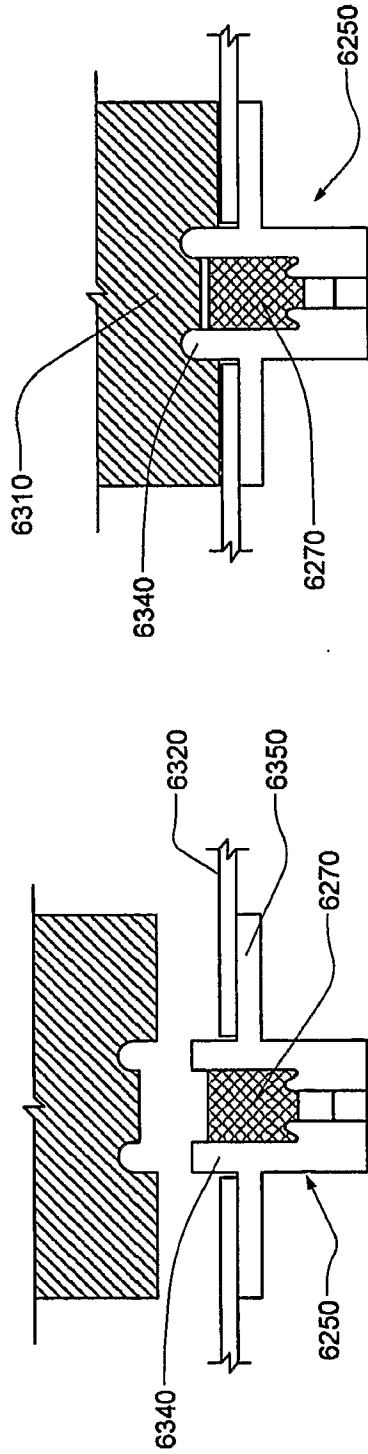

FIG. 106B

FIG. 106A

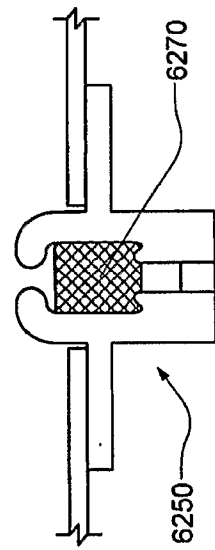

FIG. 106C

+

+

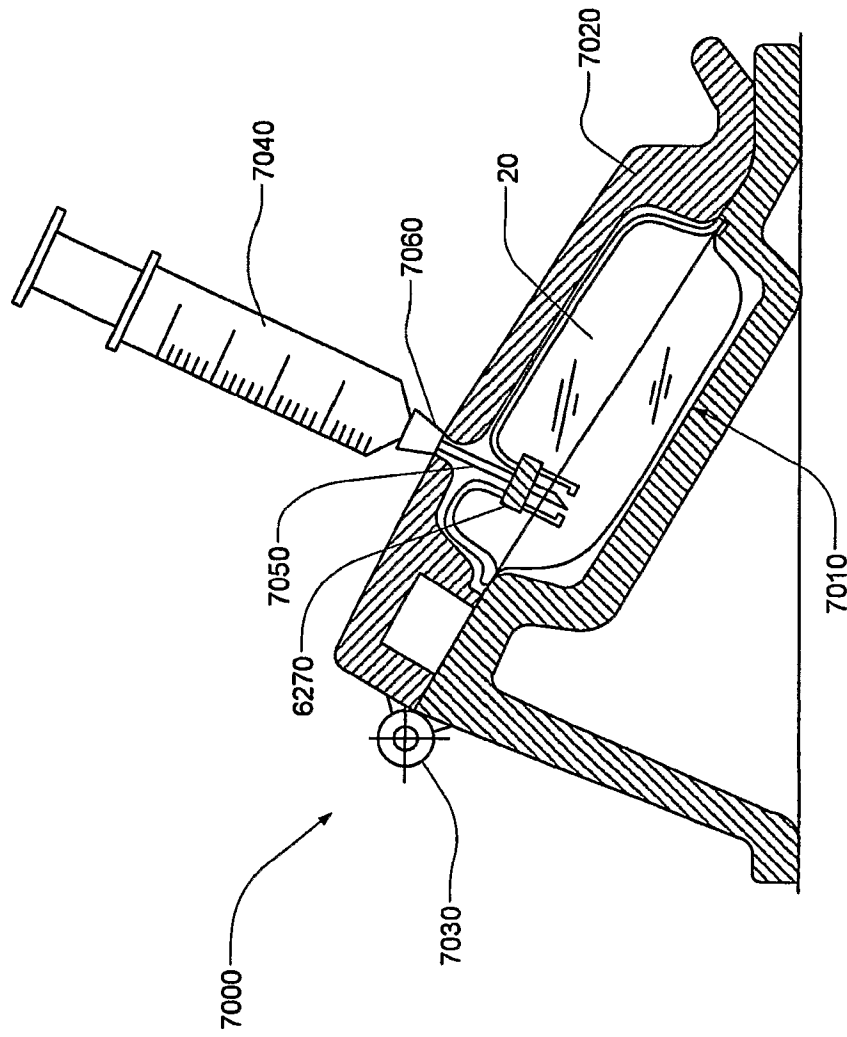

FIG. 107

+

+

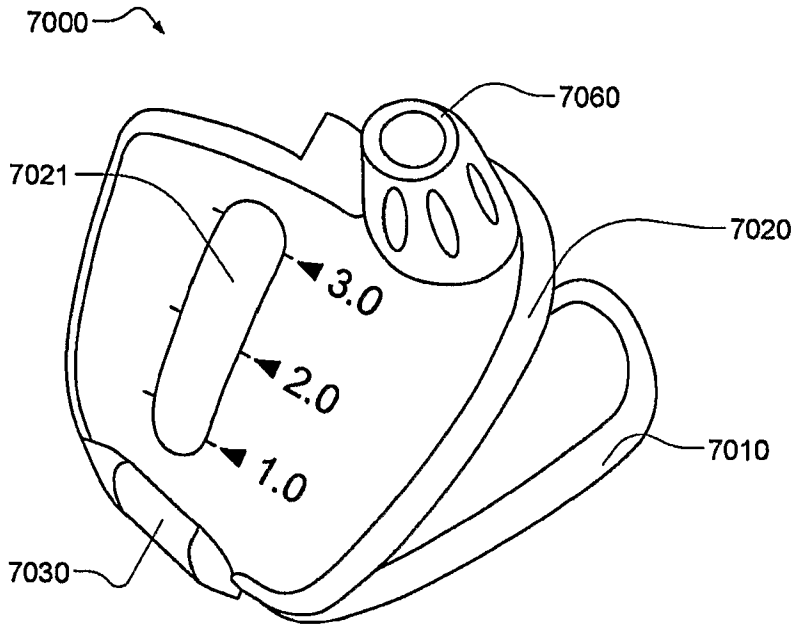

FIG. 108A

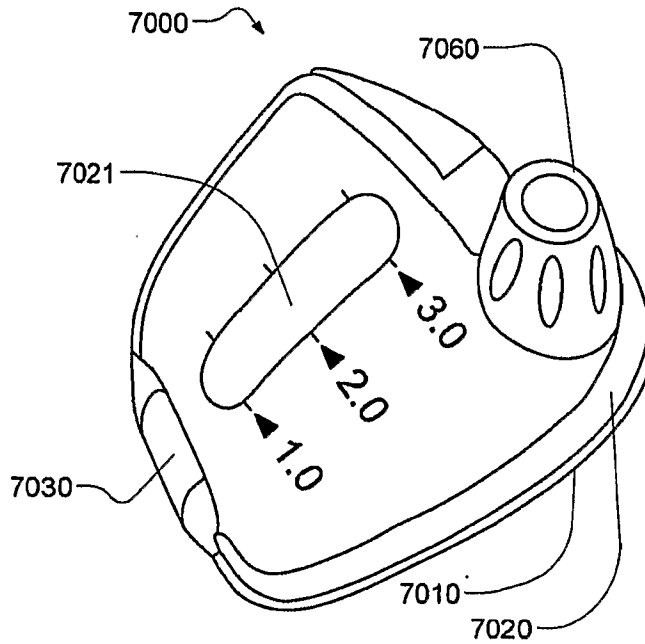

FIG. 108B

+

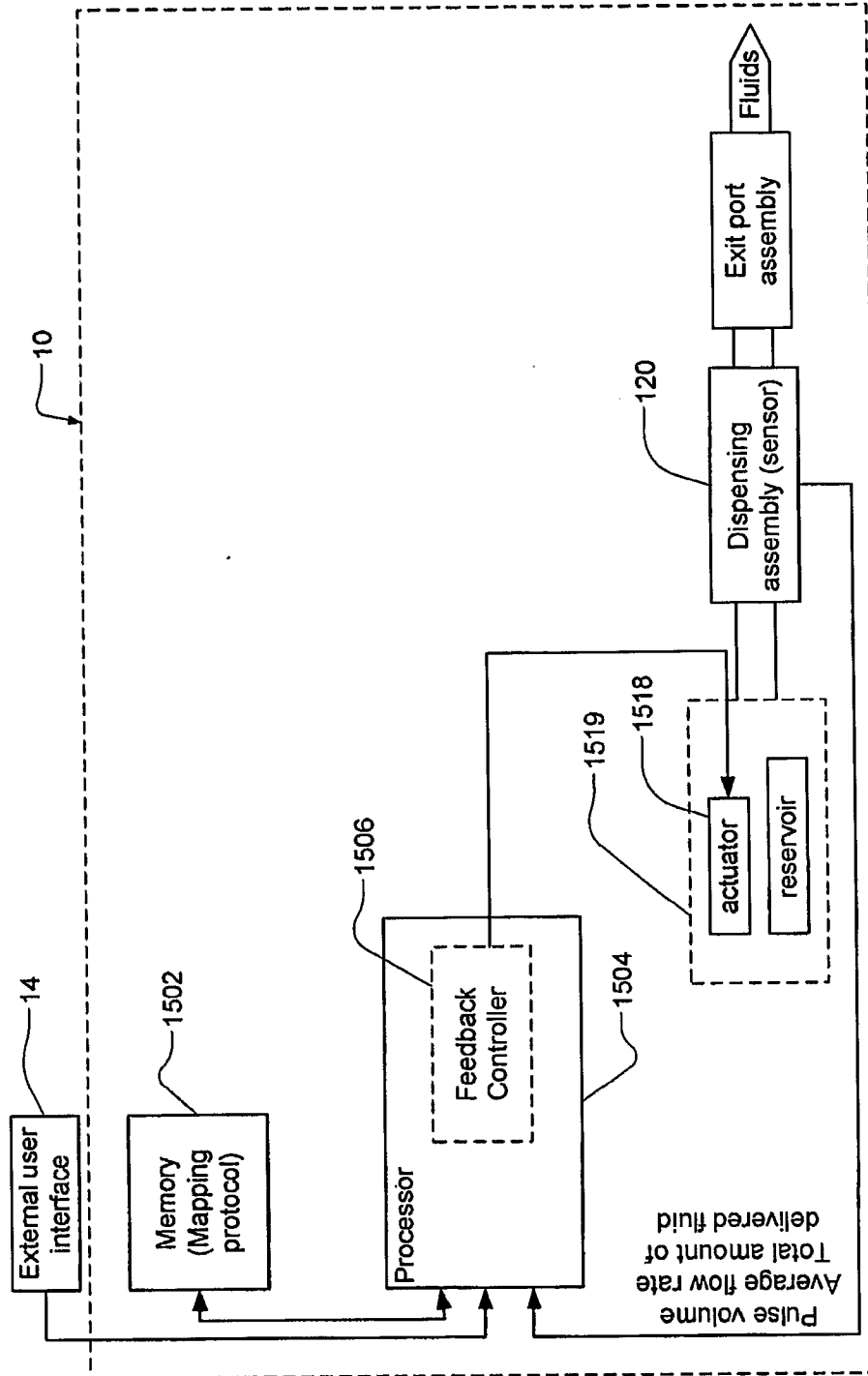

FIG. 109A



+

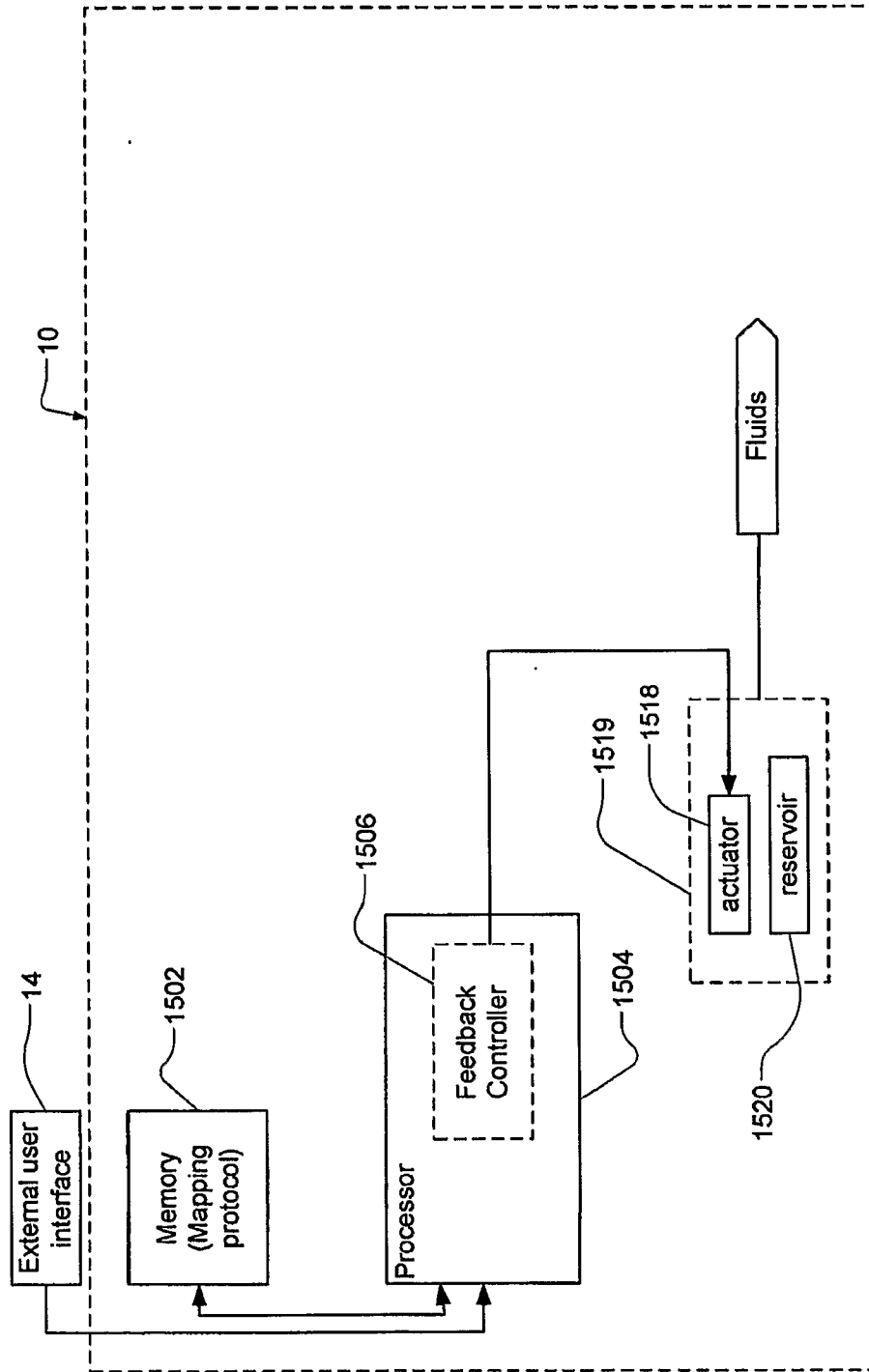

FIG. 109B

+

+

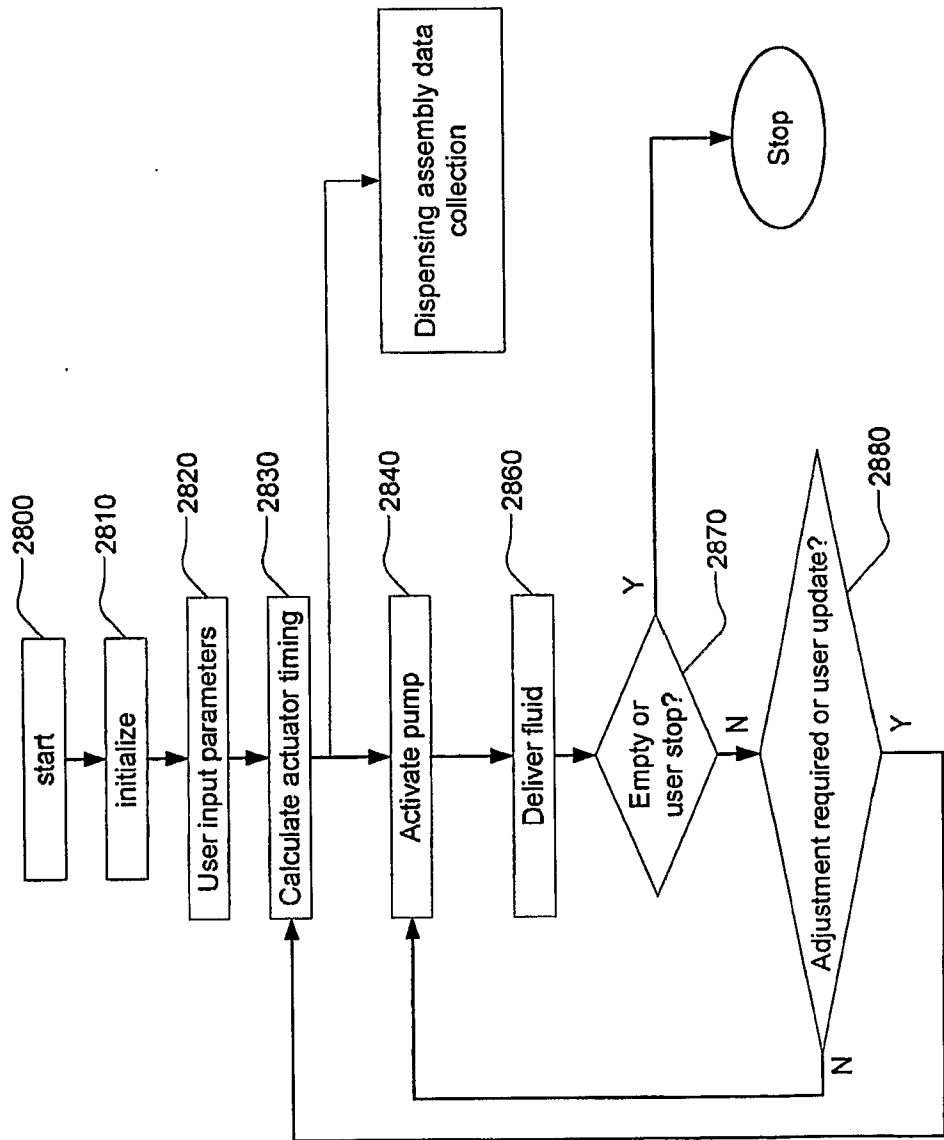

FIG. 110A

+

+

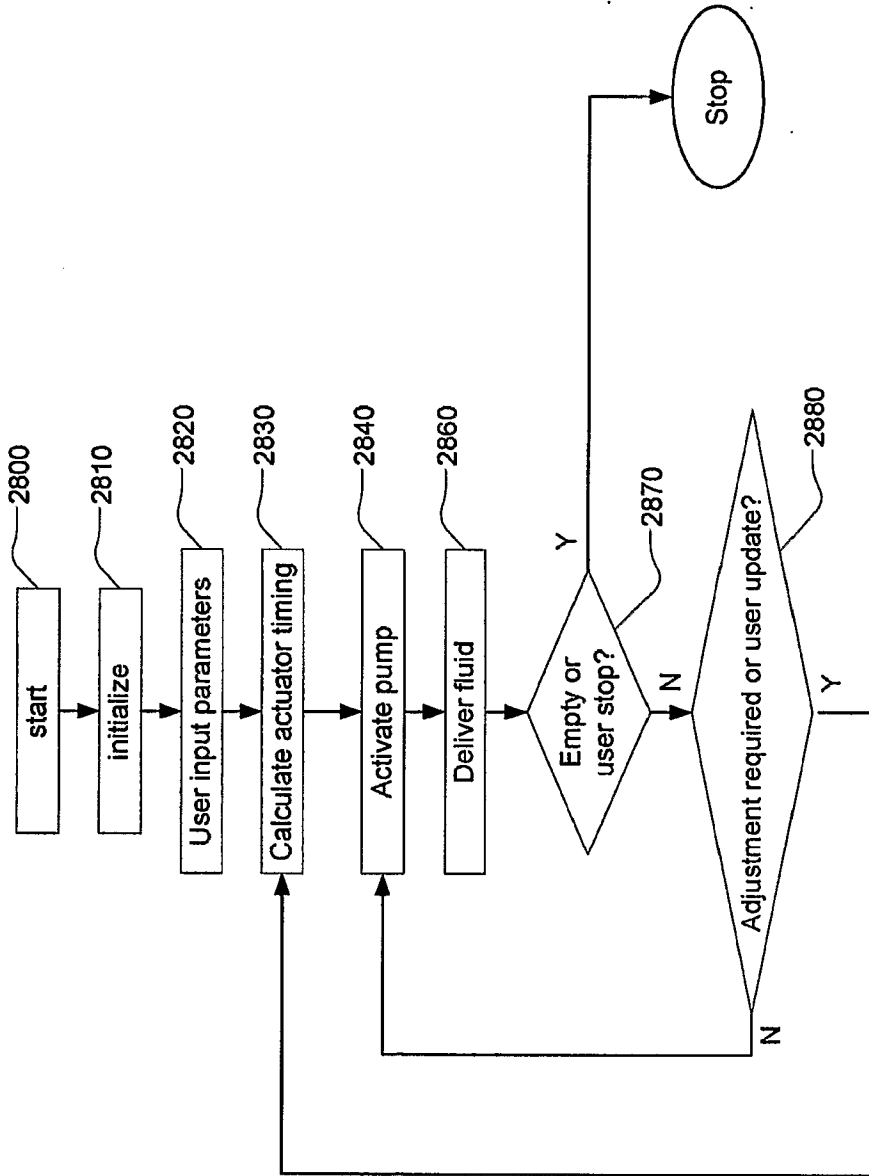

FIG. 110B

+

+

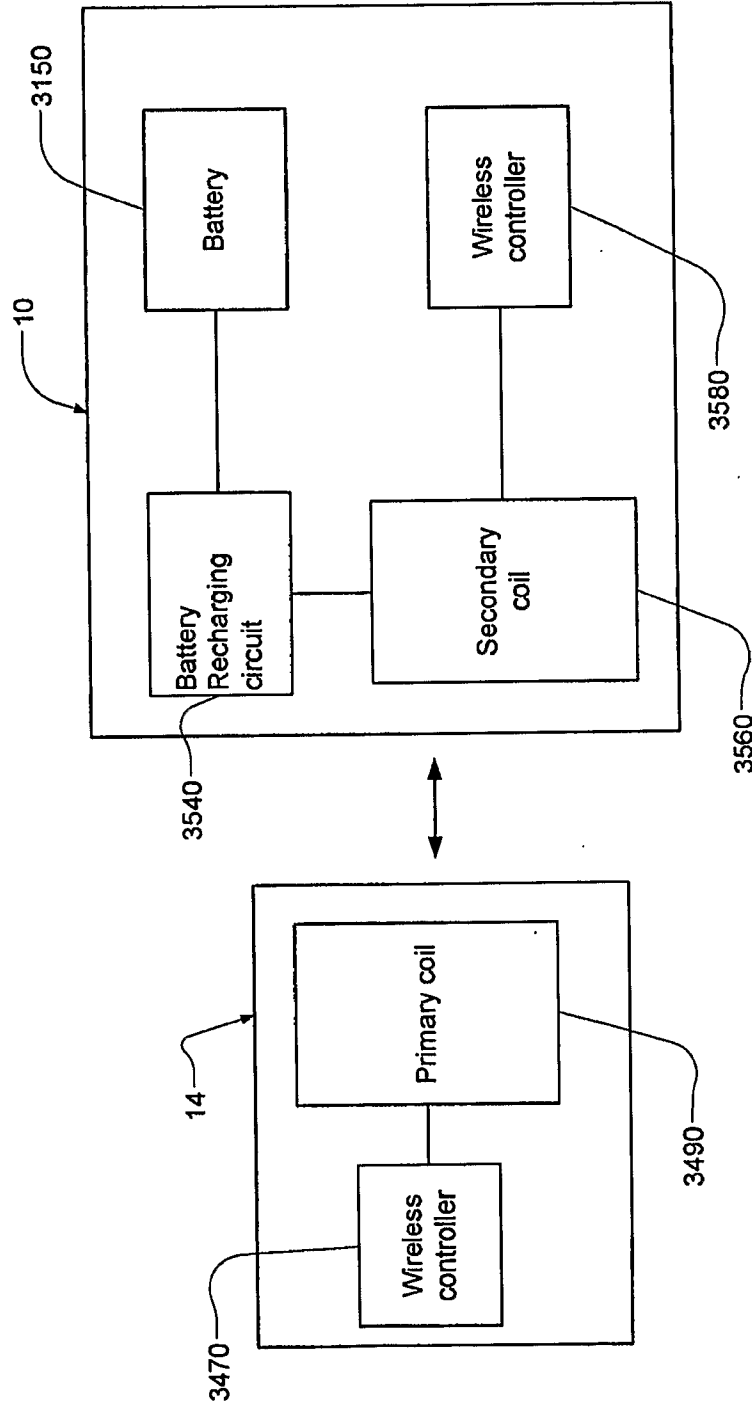

FIG. 111

+

+

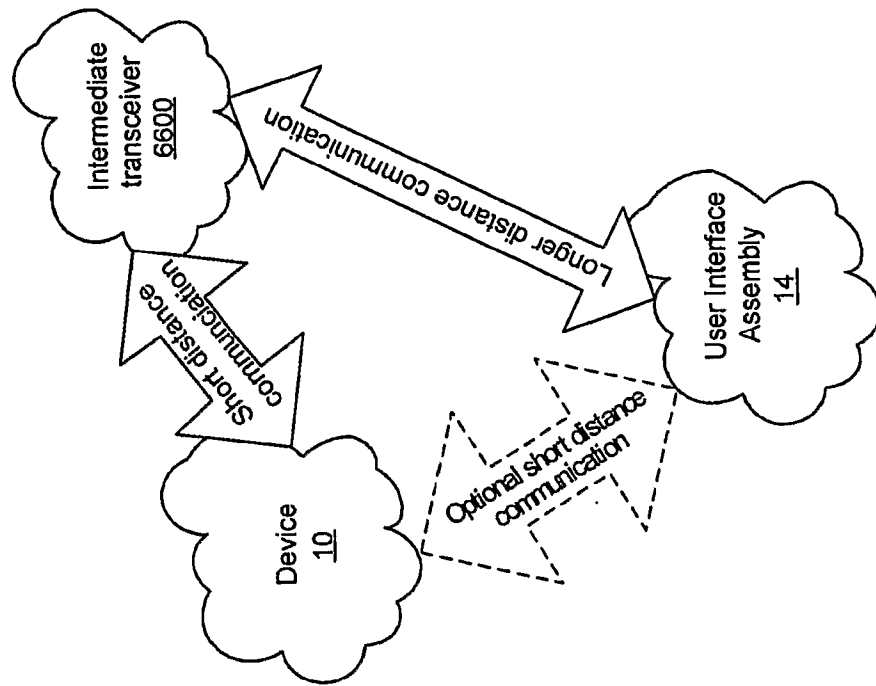

FIG. 112

+

+

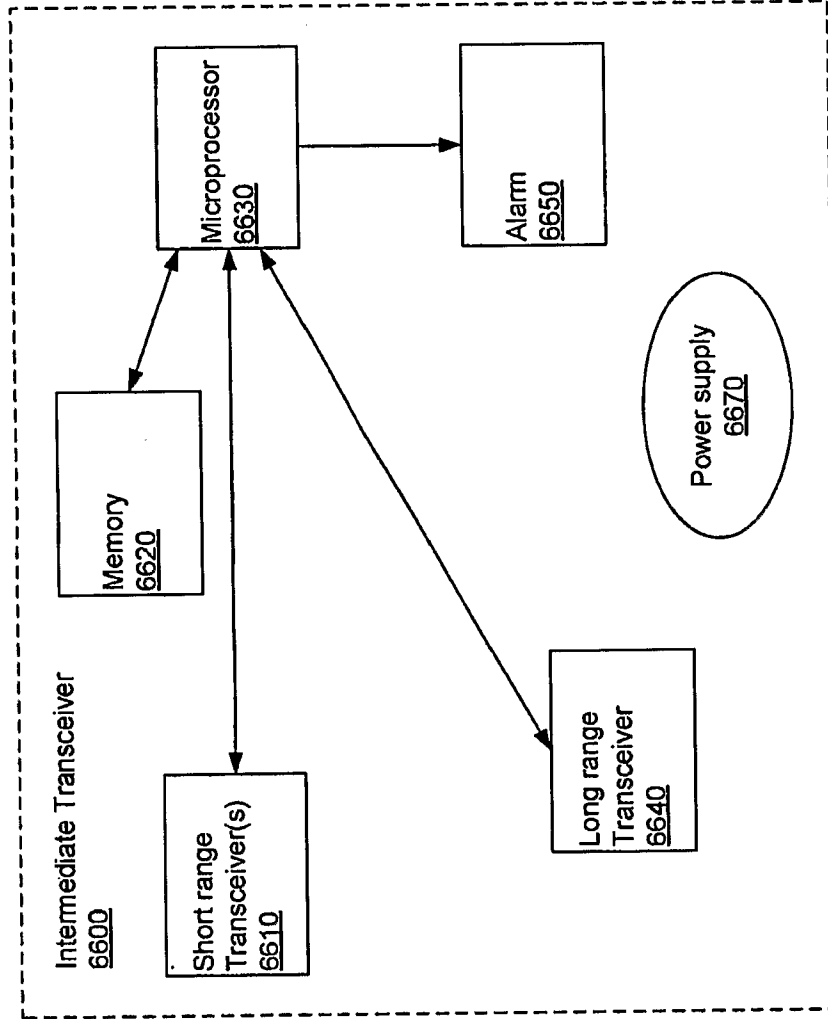

FIG. 113

+

+

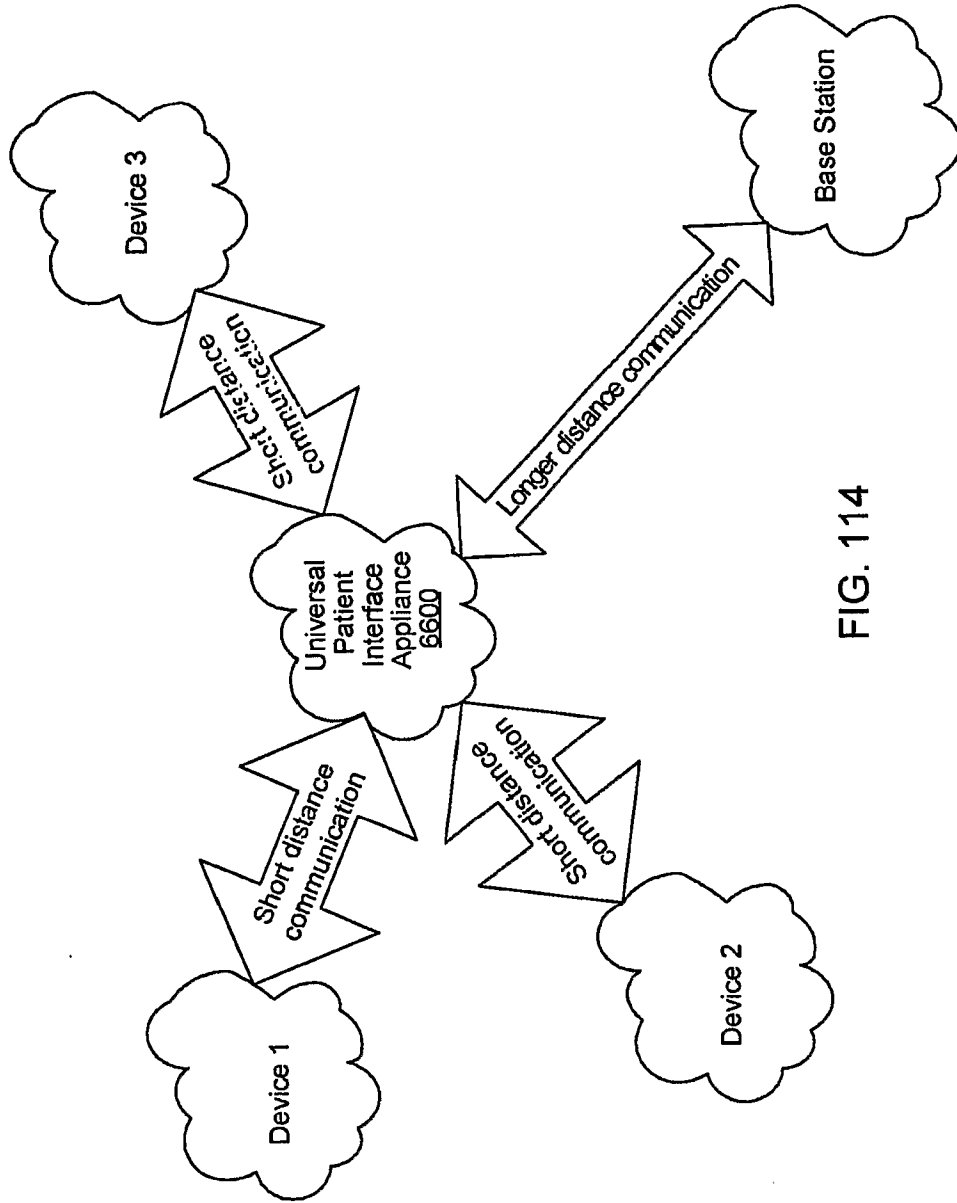

FIG. 114

+

+

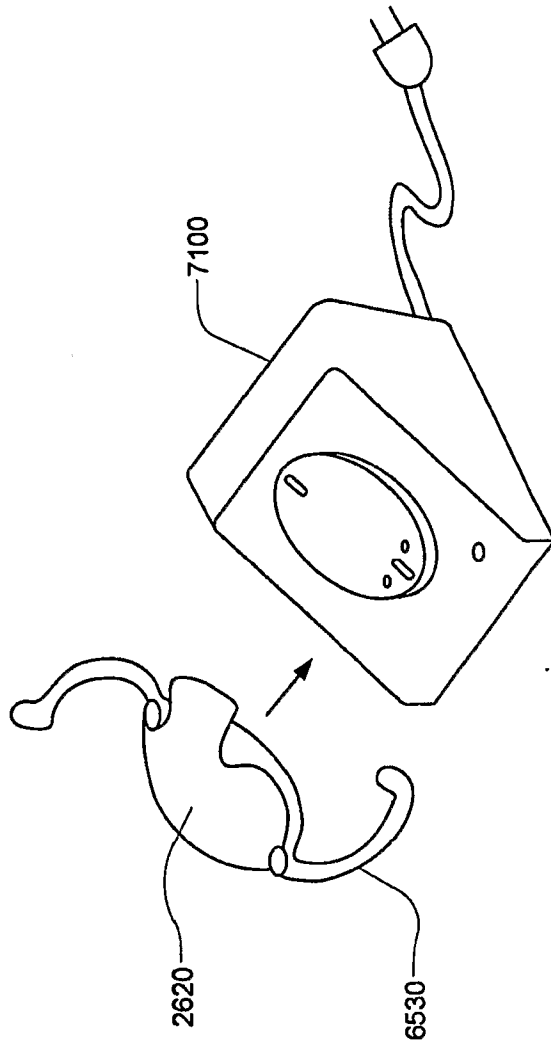

FIG. 115

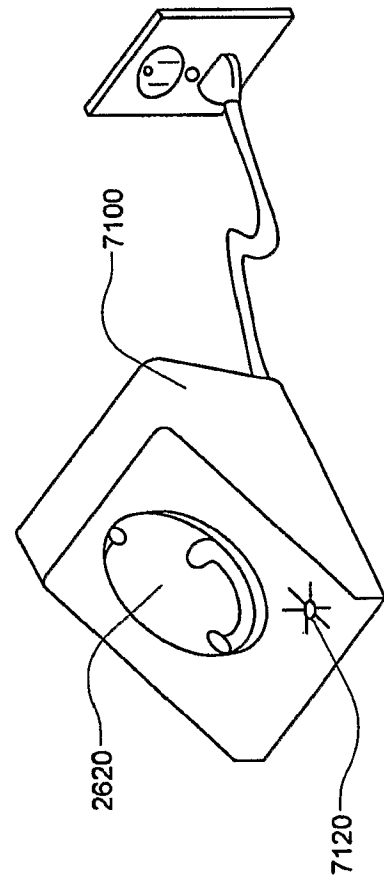

FIG. 116

+



+

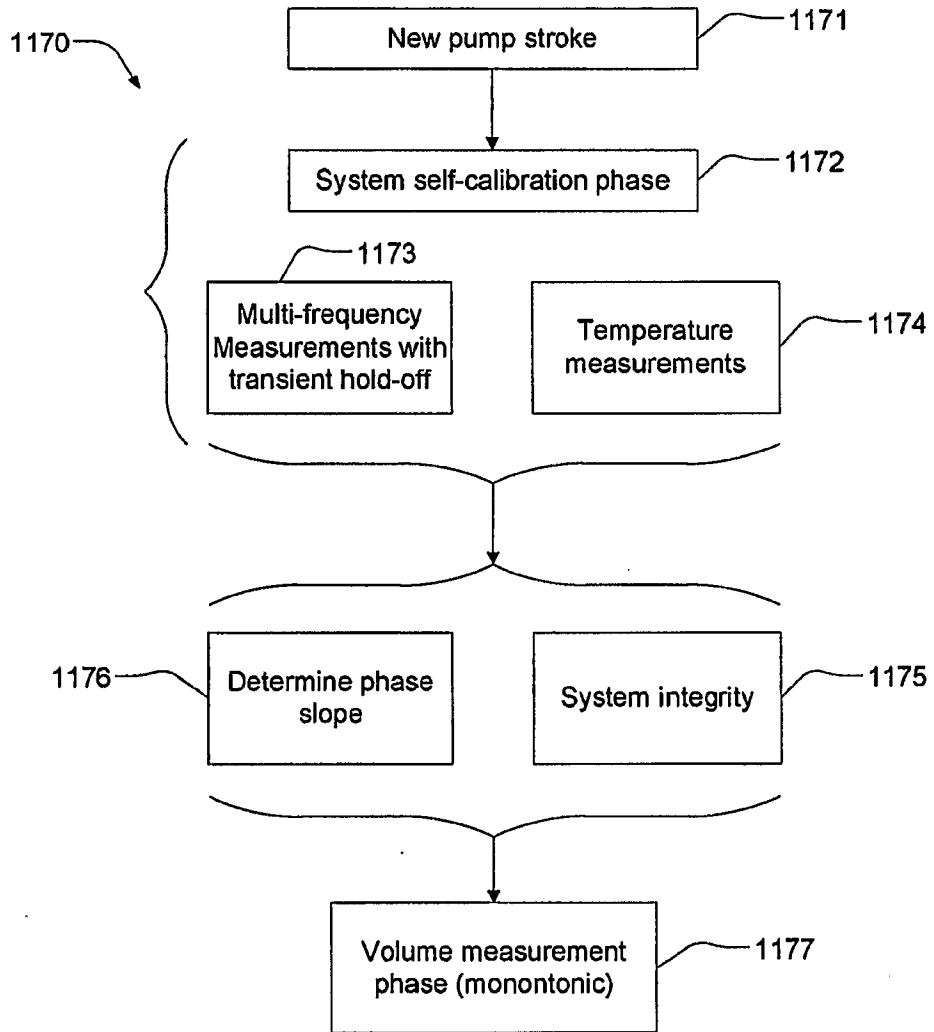

FIG. 117

+