

No. 856,313.

PATENTED JUNE 11, 1907.

A. C. TERRELL.
FLUE CONSTRUCTION FOR RANGES.

APPLICATION FILED JAN. 26, 1906.

2 SHEETS—SHEET 1.

Fig. 1.

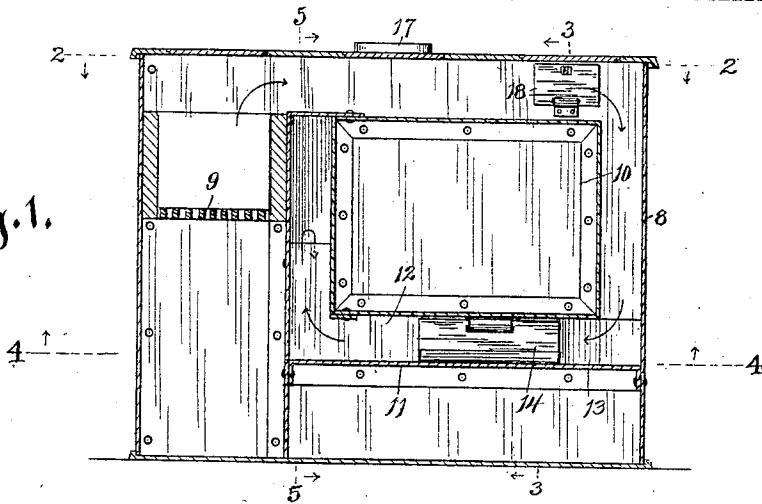

Fig. 2.

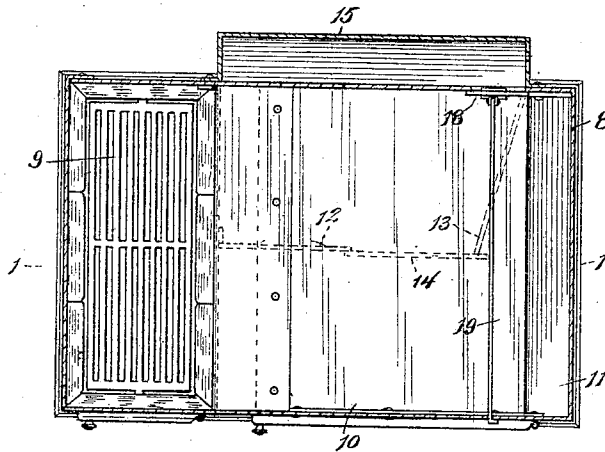
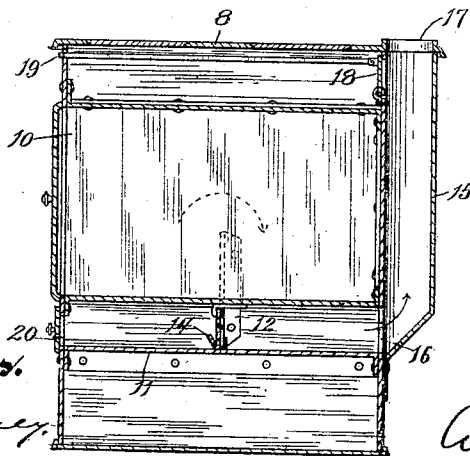

Fig. 3.



Witnesses:

W. Keene
Anna F. Schmidt

Inventor:

Albert C. Terrell

By Benedict, Morsell & Caldwell
Attorneys.

No. 856,313.

PATENTED JUNE 11, 1907.

A. C. TERRELL.
FLUE CONSTRUCTION FOR RANGES.

APPLICATION FILED JAN. 25, 1906.

2 SHEETS—SHEET 2.

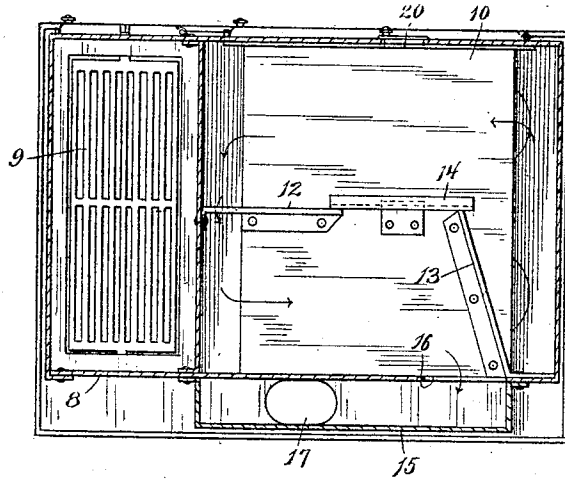

Fig. 2.

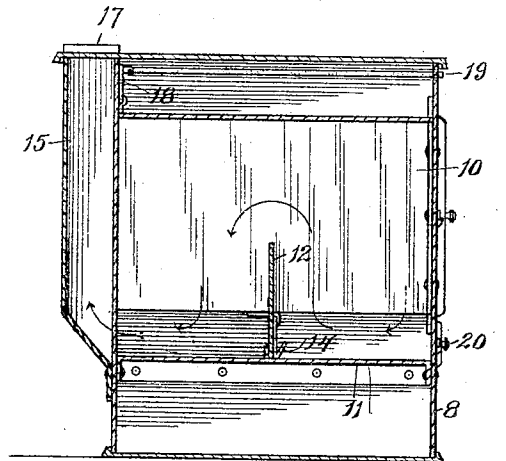

Fig. 5.

Witnesses:
C. H. Keeney
Anna F. Schmittbauer

Inventor:
Albert C. Terrell
By *Benedict, Morsell & Caldwell*
Attorneys.

UNITED STATES PATENT OFFICE.

ALBERT C. TERRELL, OF BEAVER DAM, WISCONSIN.

FLUE CONSTRUCTION FOR RANGES.

No. 856,813.

Specification of Letters Patent.

Patented June 11, 1907.

Application filed January 25, 1906. Serial No. 297,727.

To all whom it may concern:

Be it known that I, ALBERT C. TERRELL, residing in Beaver Dam, in the county of Dodge and State of Wisconsin, have invented new and useful Improvements in Flue Constructions for Ranges, of which the following is a description, reference being had to the accompanying drawings, which are a part of this specification.

This invention relates to flue constructions for ranges and has for its object to provide a flue construction which will convey the heated products of combustion around as much of the oven as possible, so as to produce an even heating effect throughout.

With the above and other objects in view the invention consists in the flue construction herein described and all equivalents thereof.

Referring to the accompanying drawings in which like characters of reference indicate the same parts in the several views:—

Figure 1 is a longitudinal sectional view of a range provided with a flue construction in accordance with this invention; Fig. 2 is a sectional plan view thereof taken on the plane of line 2—2 of Fig. 1; Fig. 3 is a transverse sectional view taken on the plane of line 3—3 of Fig. 1; Fig. 4 is a sectional plan view of the range in an inverted position taken on the plane of line 4—4 of Fig. 1; and, Fig. 5 is a transverse sectional view taken on the plane of line 5—5 of Fig. 1.

In these drawings 8 represents an ordinary range casing provided with a fire box containing a grate 9 and the rectangular oven compartment 10, all of the usual construction and arrangement. A false bottom 11 is located beneath the oven and is spaced therefrom, extending from the wall of the fire box to the end of the range casing and from the front wall to the rear wall of the range casing, to provide a flue space between it and the bottom of the oven. A partition 12 in the flue space beneath the oven extends from the wall of the fire box and co-operates with an obliquely extending partition 13 in this same flue space, running from the rear corner of the oven which is at the greater distance from the fire box to the middle of said flue space, and with a swinging door 14 pivotally connected to the bottom of the oven and normally hanging closed, to divide the flue space into separate front and rear sections.

The end wall of the oven is spaced from

the wall of the fire box to provide a flue space between them, which flue space is closed at its upper end and has extending into it for nearly half the height of the oven an upward extension of the partition 12, part way, dividing the flue space between the oven and the fire box. A supplemental back 15 in the form of a shell is applied to the back of the range casing to form a flue space between it and the back of the oven, which flue space extends from the level of false bottom 11 to the range top and from the plane of the fire box wall to the plane of the oven wall which is farther from the fire box. This flue space formed by the supplemental back 15 has communication with the rear section of the flue space beneath the oven at the end thereof which is farther from the fire box through an opening 16 in the rear wall of the range frame and has an outlet through a smoke pipe collar 17 on the range top. The flue space behind the oven may also have communication with the flue space above the oven, when it is desired to produce a direct draft for starting the fire, for an opening is provided in the rear wall of the range frame between these two flue spaces, which opening is normally closed by a door 18 controlled by a rod 19 extending through the front wall of the range frame to be operated in the usual manner. This direct draft door is located as far from the fire box as possible in order that the direct draft when the fire is being started will cross the top of the oven and give the oven the benefit of its heat.

The front of the range frame is provided with a door 20 beneath the oven door through which the swinging door 14 may be opened for the purpose of clearing out soot accumulating in the back section of the flue space beneath the oven.

Instead of the flue for the hot air and gases from the fire box extending over the top of the oven, down one end thereof, and only beneath a portion of the bottom of the oven before connecting with the chimney, as usual, in this invention it passes over the entire top surface of the oven, then down around the end of the oven, then beneath the front portion of the bottom of the oven, then through the flue space formed between the end of the oven and the fire box, passing up one side of said flue space and down the other, then through the rear section of the flue space beneath the oven to the opening 16, and finally through the flue space at the rear

of the oven to the smoke pipe. The hot air and gases are thus carried completely around five sides of the oven, and in the intermediate portion of their course, after having passed
 5 around the top and bottom and ends of the oven, they are brought against the heated wall of the fire box to become re-heated and thus impart a greater heat to the rear portion
 10 of the oven bottom and to the oven back during the remainder of their course than would otherwise be done.

With this invention the heating produced upon the oven is not local to a portion only thereof but is evenly distributed throughout
 15 the same, which improves the working of the oven and utilizes more of the heat of the fire.

What I claim as my invention is:—

1. In a range flue construction, a range frame containing a fire box and an oven with
 20 a flue space extending from the fire box entirely around the oven and back to the wall of the fire box and then beneath a portion of the oven and around the back thereof, whereby the hot air and gases are caused to become
 25 reheated after having spent a portion of their heat in warming the oven in order that they may produce a greater heating effect throughout the remainder of their course.

2. In a range flue construction, a range
 30 frame containing a fire box and an oven spaced therefrom with a flue space extending from the fire box over the oven, around the end of the oven, beneath a portion of the oven to the space between the oven and the
 35 fire box, beneath the remainder of the oven and along the back of the oven to the outlet, whereby the hot air and gases are caused to travel entirely around the top and bottom
 40 and ends of the oven and around the back of the oven.

3. In a range flue construction, a range frame containing a fire box and an oven spaced therefrom and from the range frame
 45 at the top and one end to form flue spaces, a false bottom in the range frame beneath the oven and spaced therefrom to form a flue space therebetween, and partition means between the oven and the false bottom and the
 50 wall of the fire box for dividing the flue space beneath the oven so that only one section of

said flue space is in communication with the flue space between the end of the oven and the range frame, the flue space between the end of the oven and the fire box wall being closed at its upper end and divided partway
 55 by the partition means, a supplemental back secured to the range frame behind the oven and forming a flue space therebetween having connection with the other section of the flue space beneath the oven at the end thereof
 60 which is farther from the fire box, the flue space of the supplemental back having an outlet.

4. In a range flue construction, a range frame containing a fire box and an oven spaced
 65 therefrom and from the range frame at the top and one end to form flue spaces, a false bottom in the range frame beneath the oven and spaced therefrom to form a flue space therebetween, partition means between the
 70 oven and the false bottom and the wall of the fire box for dividing the flue space beneath the oven so that only one section of said flue space is in communication with the flue space between the end of the oven and the range
 75 frame, a hinged door in said partition means, a door on the range front through which said hinged door is accessible for cleaning the flue space beneath the oven, the flue space between the end of the oven and the fire box
 80 wall being closed at its upper end and divided partway by the partition means, a supplemental back secured to the range frame behind the oven and forming a flue space therebetween having communication with the
 85 other section of the flue space beneath the oven at the end thereof which is farther from the fire box, a direct draft door in the range frame between the flue space above the oven and the flue space behind the oven with oper-
 90 ating means therefor, and a stove pipe collar on the top of the range frame forming an outlet for the flue space behind the oven.

In testimony whereof, I affix my signature, in presence of two witnesses.

ALBERT C. TERRELL.

Witnesses:

PETER BEULE,
 A. F. REEDE.