

[54] **MARINE MUFFLERS**

[72] Inventor: **William M. Betts**, 302 Northeast 45th Court, Pompano Beach, Fla. 33064

[22] Filed: **June 15, 1970**

[21] Appl. No.: **46,423**

[52] U.S. Cl. .... **181/57, 181/61**

[51] Int. Cl. .... **F01n 1/08**

[58] Field of Search ..... **181/39, 43, 47, 51, 52, 57, 181/61, 70, 68, 69**

[56]

**References Cited**

**UNITED STATES PATENTS**

2,877,860	3/1959	Hoffar .....	181/39 UX
2,933,148	4/1960	Hendry .....	181/61 X
3,187,837	6/1965	Beeching .....	181/69 X
1,067,200	7/1913	Shlosberg .....	181/70
1,991,014	2/1935	Compo .....	181/47
3,220,506	11/1965	Vernet .....	181/61 X

3,080,939	3/1963	Kelly .....	181/61 UX
2,122,086	6/1938	Chase .....	181/70 X
2,511,597	6/1950	Marx .....	181/61 UX
3,077,240	2/1963	Betts .....	181/61 X

*Primary Examiner*—Richard B. Wilkins

*Assistant Examiner*—John F. Gonzales

*Attorney*—Erwin A. Yaeger

[57]

**ABSTRACT**

A muffler for marine engines comprising a shell or body composed of two half sections integrally joined to produce an outer chamber having an inlet and an outlet port, an inner chamber in the shell having a perforated or foraminous cone at one end of said inner chamber, said cone establishing communication between the chambers, the inner chamber having laterally extending ports at its end remote from the cone, said ports communicating with the outer chamber and with the outlet of said outer chamber. The halves of the outer shell can be fitted together in numerous ways to thereby align or disalign the inlet and outlet ports of the shell.

**5 Claims, 7 Drawing Figures**

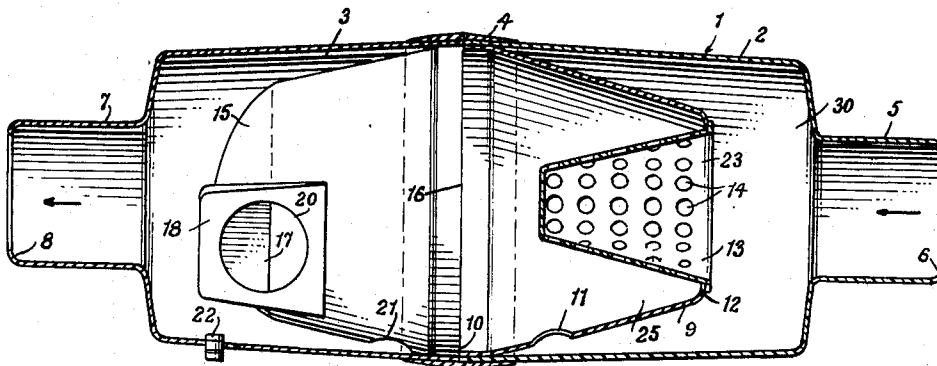

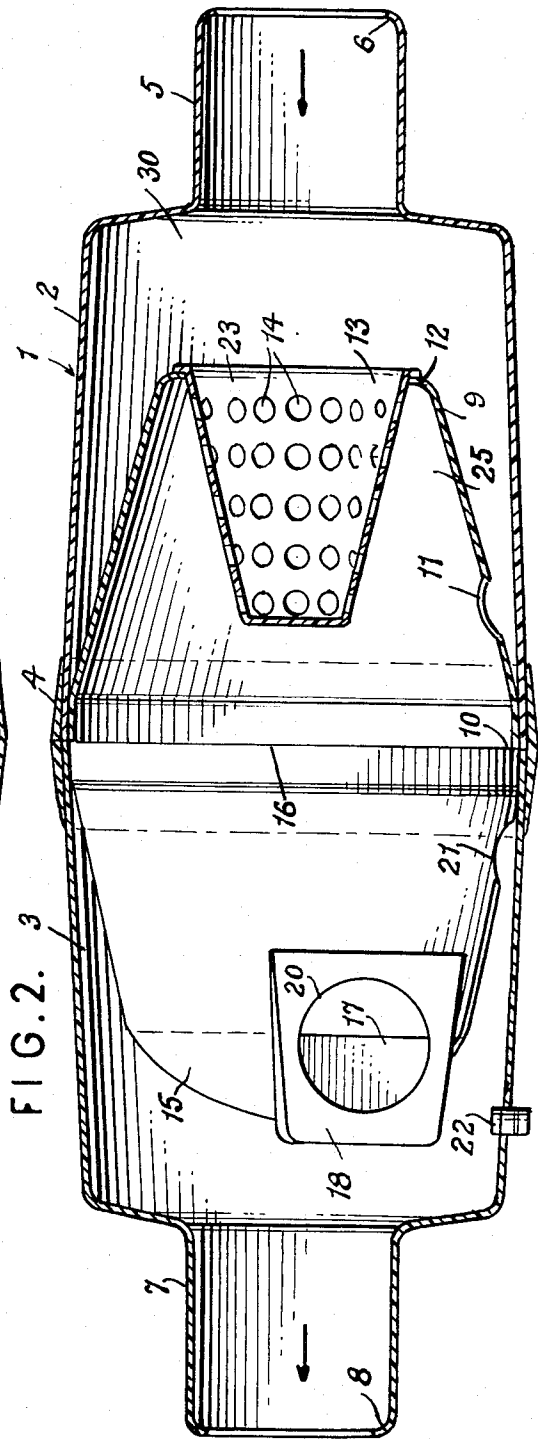
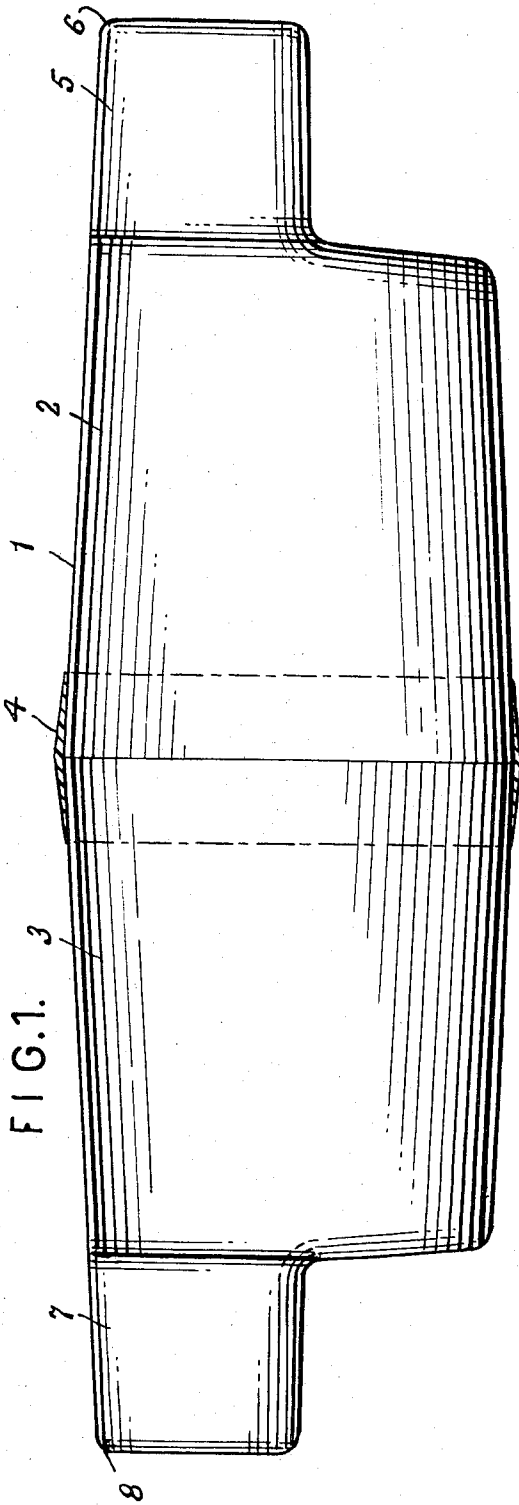

INVENTOR  
**William M. Betts**  
BY *Ernest A. Long*  
ATTORNEY

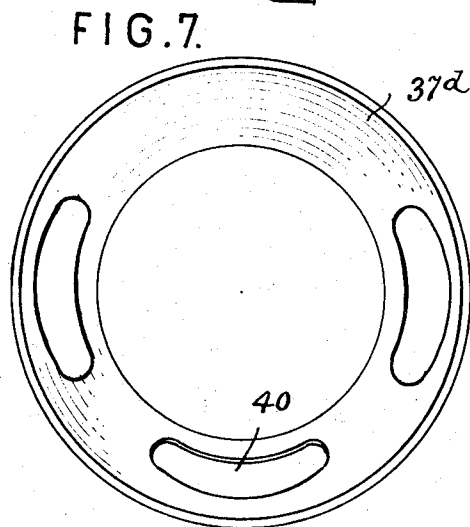
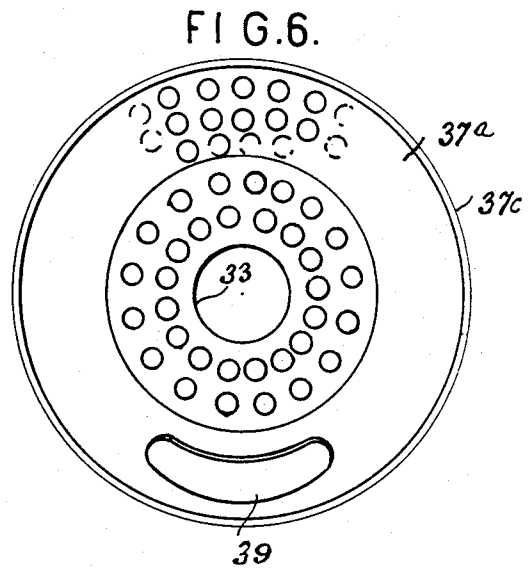
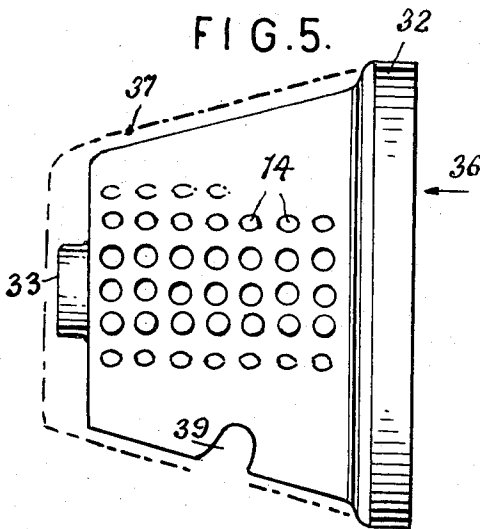
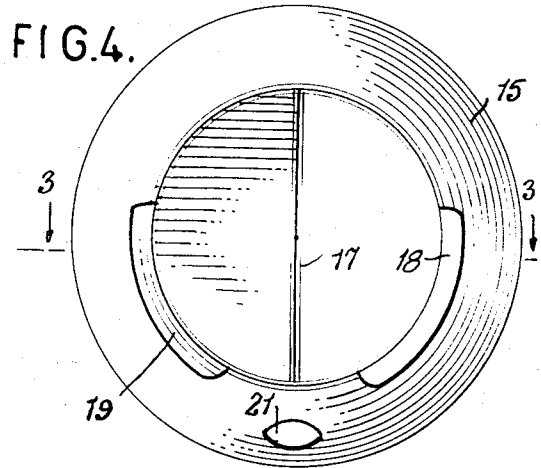
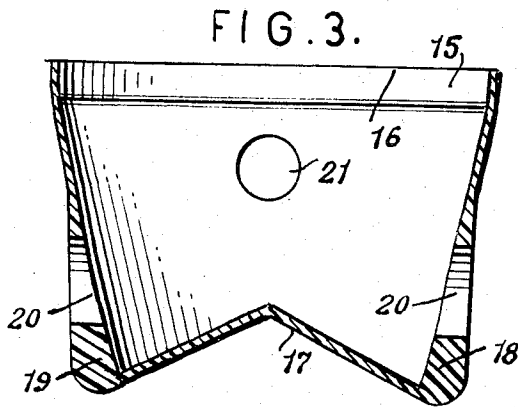

INVENTOR  
**William M. Betts**  
BY *James A. [Signature]*  
ATTORNEY

## MARINE MUFFLERS

It is an object of the invention to provide a muffler, and one particularly adapted for use in connection with marine engines and so constructed as to provide for a minimum of noise and back pressure. It is another object of the invention to provide a muffler composed of a molded seamless material such as fiber glass, thus avoiding rust, corrosion and electrolysis formation and resulting in long life and light weight.

In the accompanying drawings, wherein an illustrative embodiment of the invention is disclosed,

FIG. 1 is an elevational view of a muffler constructed in accordance with the invention;

FIG. 2 is a longitudinal sectional view of the same;

FIG. 3 is a sectional view of one of the baffles, the view being taken substantially on the line 3—3 of FIG. 4, looking in the direction of the arrows;

FIG. 4 is an end view of the baffle shown in FIG. 3;

FIG. 5 is a slightly modified form of baffle;

FIG. 6 is an end view of the baffle shown in FIG. 5, looking in the direction of the arrows 36; and,

FIG. 7 in another type of baffle, using liner FIG. 6.

In the accompanying drawings, with particular reference to FIGS. 1 and 2, the outer body or shell of the muffler is generally indicated at 1 and is of the form shown, the same being preferably composed of a suitable heat-resistant plastic material such as fiber glass.

The outer body or shell 1 is composed of two similar half sections indicated respectively at 2 and 3. These sections are circular at one end and have these circular larger ends disposed in abutment and these ends are joined together by an overlying laminated fiber glass strip or band 4. This strip or band is permanently secured in position over the joint between the halves 2 and 3 of the shell, and such strip or band consists of a fiber glass mat and liquid resin mixed with a catalyst which causes the strip or band to be bonded to and halves of the shell thus bonding them together and resulting in a permanent joint between them. The result is a strong, hollow, seamless one-piece body or shell for the muffler.

At one end the shell-half 2 is formed with a port nipple or boss constituting an inlet into the outer chamber 30 of the shell. A hose or tubing extending from the engine can be attached to the boss 5. The end of the boss 5 is slightly inturred or flanged as shown at 6 to facilitate a ready attachment of the hose.

The second half 3 of the shell 1 is also provided with a boss 7, constituting an outlet port for the muffler, said boss having an inturred end or flange 8 similar to that shown at 6 on the boss 5.

In assembling the two halves 2 and 3 of the shell 1, these halves may be fitted together in such a manner that the inlet and outlet openings 5 and 7 are in axial alignment as shown in FIG. 2 or if desired the halves of the shell can be so assembled that the inlet will be disaligned to any desired extent from the outlet 7 to meet any special mounting requirements or for any other purpose. This is possible due to the off-center arrangement of the ports 5 and 7 to the shell sections on which they are formed.

Contained within the section 2 of the outer shell or body 1 is a conical member or baffle 9 having its larger end 10 of circular form located at the transverse center line of the shell 1 and secured in the section 2 thereof. This conical member 9 has one or more drain holes 11 communicating with the outer chamber 30, and in its smaller end 12 is fitted a perforated frusto-conical member or cone 13. This cone 13 has its smaller end facing toward the center of the shell and the cone is all-over perforated as at 14 so that it is in fact foraminous.

The section 3 of the shell 1 contains an insert 15 constituting a baffle and which is substantially cup-shaped and has its larger end secured to section 3 at the center of the shell 1. The two baffles 9 and 15 thus co-operate in the formation of an inner chamber 25. The opposite end of the insert or baffle 15 is closed and is indented as shown at 17 for exhaust deflection. Provided at opposite sides of this indentation are lugs 18, 19, formed integrally with the baffle 15 each of these lugs being

apertured as shown at 20, the apertures extending laterally through the baffle 15 and communicating with the interior chamber 25. When fitting the baffle 15 in the shell section 3, the baffle may be rotatively adjusted relatively to the outlet hole 21 is at the bottom and is kept in position as shown in FIG. 2 while the port 7 is rotated to suit any special installation requirement. Also, as heretofore stated, the exhaust outlet 7 may be axially disaligned from the inlet 5. These positions are arranged during the assembly of the muffler, thus creating a number of arrangements to suit installation requirements.

A drain hole 21 is provided in the wall of the baffle 15 and another drain hole, normally closed by a plug 22, is provided in the wall of the shell section 3.

A muffler constructed in accordance with the present invention tends to materially reduce noise and gas odors and also facilitates installation. The opening 23 at the larger end of the perforated cone 13, and which end faces the inlet port 5, is preferably slightly larger than the inlet port. Also, the holes 14 in the cone equal or possible exceed in combined area the square area of the inlet port 5.

The holes 20 extending through the lug portions 18 and 19 are arranged transverse to the longitudinal axis of the shell of the muffler. The total area of the holes 20, 20 and 21 exceeds an area defined by the port 5 or 7.

The arrangement described is such that there is a continuous mixing of water and gases as these fluids impinge against the inner wall surfaces of the outer chamber 30 to pass therefrom into the inner chamber 25; out through the lateral openings 20, 20 and thence out of the outlet port 7. Very little noise and odor is the result.

By the provision of the foraminous cone 13, and by possibly varying the size of the holes extending through it, the sound frequency is mixed, broken up and lessened. By forcing the hot gases and water (the latter being injected into the exhaust line in advance of the muffler) through the openings, an atomizing and mixing effect is obtained when the fluids impinge and bounce off the wall of the chamber 25. This action cools the gases quickly, not only reducing noise but also eliminating much of the odor being absorbed by the watery vapors.

In the embodiment of the invention shown in FIGS. 5, 6 and 7, there is seen a frusto-conical member or baffle 32. The baffle 32 is all-over perforated as at 14 or is foraminous and is mounted in the manner of the baffle 13. A relatively large hole 33, preferably of greater area than the area of the outlet port 7, is provided in the end wall of the baffle 32. For strength and possible greater sound reduction a lining 37a can, if desired, be used inside of the baffle 32. Said lining is perforated as seen in FIG. 6. An outer covering 37c might also be fitted over the baffle 32 as shown in dotted lines 37 in FIG. 5. An aperture 39 is provided in the baffle 32 and also in the covering 37c. Another arrangement is one in which a baffle 37d provided with a number of apertures 40 is employed alone or in conjunction with any of the other baffles herein disclosed.

In the described embodiments, a light-weight one-piece heat-resistant muffler is provided and one in which several adjustments of the inlet and outlet ports relatively to one another can be made during the assembly of the parts. This is possible due to the offset disposition of the ports that are respectively located in the half sections of the shell and also due to the fact that those portions of the shell which come together are of circular formation.

What I claim is:

1. A muffler comprising, an outer shell composed of two half sections attached end-to-end to form a hollow outer shell, one of the sections having an inlet and the other section having an outlet, the sections being rotatably adjustable before their attachment to one another to either axially align or disalign the inlet and outlet, an inner shell section located within and spaced from the outer shell, the inner shell having wall openings communication with the interior of the outer shell, the inner shell having an end opening located adjacent to the inlet of the outer shell, said end opening containing a per-

3

forated cone having a larger end facing the inlet and having its smaller end directed into the inner shell.

2. A muffler according to claim 1 wherein an end area of the inner shell is provided with its openings directed laterally and communicating with the interior of the outer shell, and the end of the inner shell that is located adjacent to said lateral openings being indented to provide angular exhaust deflecting surfaces adjacent to said openings.

3. A muffler having a shell constituting an outer chamber, an inner chamber located within the outer chamber, said inner chamber being composed of a pair of frusto-conical sections having their larger ends meeting to co-operate in the formation of a hollow body tapered at its opposite ends, the first of said ends being composed of a foraminous cone having a smaller end directed into the inside of the inner chamber, the outer chamber having an inlet opening, the larger end of the foraminous cone being directed toward said opening, the second end of the inner chamber being closed at its smaller end and being provided with exhaust openings in its side wall.

4

4. A muffler according to claim 3, wherein the closed end wall of the second end of the inner chamber is indented to form a pair of deflecting surfaces arranged angularly to deflect exhaust vapors toward the openings in the side wall of the second end of the inner chamber.

5. A muffler having a shell defining an outer hollow chamber provided with inlet and outlet openings, an inner chamber located within the outer chamber, said inner chamber being composed of a pair of frusto-conical sections meeting at their larger ends so that the frusto-conical sections have their smaller ends respectively directed toward the inlet and outlet openings in the outer shell, one of the frusto-conical sections having a foraminous end wall composed of a perforated cone which has a small end directed away from the small end of the frusto-conical section to which it is attached, the second frusto-conical section having outlet openings in its side wall only.

\* \* \* \* \*

20

25

30

35

40

45

50

55

60

65

70

75