



- (51) International Patent Classification:
B65D 5/50 (2006.01) *B65D 81/05* (2006.01)
- (21) International Application Number:
PCT/US2015/019838
- (22) International Filing Date:
11 March 2015 (11.03.2015)
- (25) Filing Language: English
- (26) Publication Language: English
- (30) Priority Data:
61/967,133 11 March 2014 (11.03.2014) US
- (71) Applicant: GRAPHIC PACKAGING INTERNATIONAL, INC. [US/US]; Law Department-9th Floor, 1500 Riveredge Parkway, Suite 100, Atlanta, GA 30328 (US).

- (72) Inventors: **BOERSMA, Harmen**; Scholeksterstraat 24, NL-8446 JP Heerenveen (NL). **KNIJPSTRA, Rene**; Molenlaan 17, NL-8461 LJ Rottum (NL). **HILARIDES, Jouke**; Skerwald 1, NL-8618 NE Oosthem (NL).
- (74) Agent: **CLAERBOUT, Andrew N.**; Womble Carlyle Sandridge & Rice LLP, P.O. Box 7037, Atlanta, GA 30357-0037 (US).
- (81) Designated States (*unless otherwise indicated, for every kind of national protection available*): AE, AG, AL, AM, AO, AT, AU, AZ, BA, BB, BG, BH, BN, BR, BW, BY, BZ, CA, CH, CL, CN, CO, CR, CU, CZ, DE, DK, DM, DO, DZ, EC, EE, EG, ES, FI, GB, GD, GE, GH, GM, GT, HN, HR, HU, ID, IL, IN, IR, IS, JP, KE, KG, KN, KP, KR, KZ, LA, LC, LK, LR, LS, LU, LY, MA, MD, ME, MG, MK, MN, MW, MX, MY, MZ, NA, NG, NI, NO, NZ, OM,

[Continued on next page]

(54) Title: CARTON WITH INSERT

(57) Abstract: A carton for holding an article. The carton can comprise a plurality of panels that extends at least partially around an interior of the carton. The plurality of panels can comprise a first panel and a second panel. An insert can comprise a central panel, an inner side panel foldably connected to the central panel, and an inner flap foldably connected to the inner side panel. The first panel can at least partially overlap the central panel, the inner side panel can be spaced apart from the second panel, and at least a portion of the inner flap can extend from the inner side panel to the second panel.

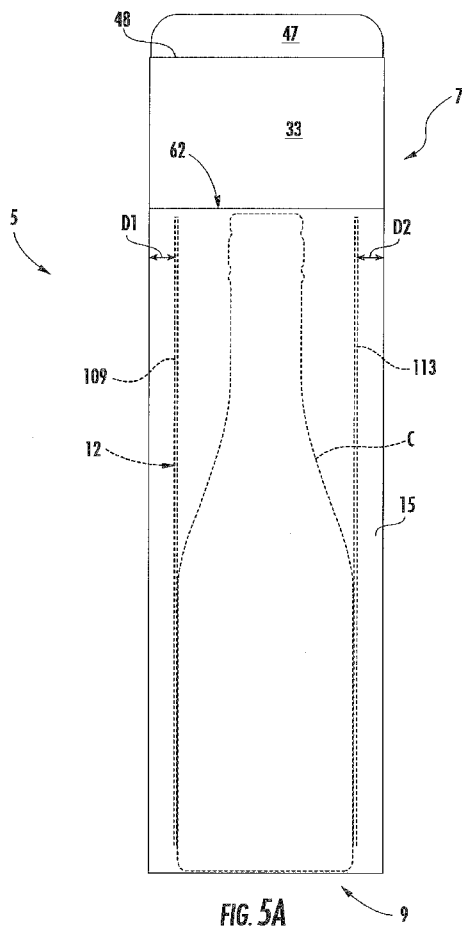

WO 2015/138537 A1

PA, PE, PG, PH, PL, PT, QA, RO, RS, RU, RW, SA, SC, SD, SE, SG, SK, SL, SM, ST, SV, SY, TH, TJ, TM, TN, TR, TT, TZ, UA, UG, US, UZ, VC, VN, ZA, ZM, ZW.

(84) Designated States (unless otherwise indicated, for every kind of regional protection available): ARIPO (BW, GH, GM, KE, LR, LS, MW, MZ, NA, RW, SD, SL, ST, SZ, TZ, UG, ZM, ZW), Eurasian (AM, AZ, BY, KG, KZ, RU, TJ, TM), European (AL, AT, BE, BG, CH, CY, CZ, DE, DK, EE, ES, FI, FR, GB, GR, HR, HU, IE, IS, IT, LT, LU, LV, MC, MK, MT, NL, NO, PL, PT, RO, RS, SE, SI, SK, SM, TR), OAPI (BF, BJ, CF, CG, CI, CM, GA, GN, GQ, GW, KM, ML, MR, NE, SN, TD, TG).

Declarations under Rule 4.17:

- as to applicant's entitlement to apply for and be granted a patent (Rule 4.17(ii))
- as to the applicant's entitlement to claim the priority of the earlier application (Rule 4.17(iii))

Published:

- with international search report (Art. 21(3))

CARTON WITH INSERT**CROSS REFERENCE TO RELATED APPLICATIONS**

[0001] This application claims the benefit of U.S. Provisional Patent Application No. 61/967,133, filed March 11, 2014.

INCORPORATION BY REFERENCE

[0002] The disclosure of U.S. Provisional Patent Application No. 61/967,133, which was filed on March 11, 2014, is hereby incorporated by reference for all purposes as if presented herein in its entirety.

BACKGROUND OF THE DISCLOSURE

[0003] The present disclosure generally relates to cartons for holding beverage containers or other types of articles. More specifically, the present disclosure relates to cartons having an insert.

SUMMARY OF THE DISCLOSURE

[0004] In general, one aspect of the disclosure is directed to a carton for holding an article. The carton can comprise a plurality of panels that extends at least partially around an interior of the carton. The plurality of panels can comprise a first panel and a second panel. An insert can comprise a central panel, an inner side panel foldably connected to the central panel, and an inner flap foldably connected to the inner side panel. The first panel can at least partially overlap the central panel, the inner side panel can be spaced apart from the second panel, and at least a portion of the inner flap can extend from the inner side panel to the second panel.

[0005] In another aspect, the disclosure is generally directed to, in combination, a carton blank and an insert blank for forming a carton and an insert at least partially disposed in the carton for holding an article. The carton blank can comprise a plurality of panels comprising a first panel and a second panel. The insert blank can comprise a central panel, an inner side panel foldably connected to the central panel, and an inner flap foldably connected to the inner side panel. The first panel can be for at least partially overlapping the central panel when the carton is formed from the carton blank and the insert blank. The inner side panel can be for being spaced apart from the second panel and at least a portion of the inner flap can be for extending from the inner side panel to the second panel when the carton and the insert are formed from the carton blank and the insert blank.

[0006] In another aspect, the disclosure is generally directed to a blank for forming a carton for holding an article. The blank can comprise a first portion comprising a plurality of panels comprising a first panel and a second panel. The blank further can comprise a second portion for forming an inner spacer feature in the carton formed from the blank. The second portion can comprise a central panel, an inner side panel foldably connected to the central panel, and an inner flap foldably connected to the inner side panel. The first panel can be for at least partially overlapping the central panel when the carton is formed from the blank. The inner side panel can be for being spaced apart from the second panel and at least a portion of the inner flap can be for extending from the inner side panel to the second panel when the carton is formed from the blank.

[0007] In another aspect, the disclosure is generally directed to a method of forming a carton for holding an article. The method can comprise obtaining a carton blank and an insert blank. The carton blank can comprise a plurality of panels comprising a first panel and a second panel, and the insert blank can comprise a central panel, an inner side panel foldably connected to the central panel, and an inner flap foldably connected to the inner side panel. The method further can comprise forming an interior of the carton at least partially defined by the plurality of panels of the carton blank. The forming the interior of the carton can comprise forming an open-ended sleeve. The method also can comprise forming an insert from the insert blank. The first panel can at least partially overlap the central panel, the inner side panel can be spaced apart from the outer side panel, and at least a portion of the inner flap can extend from the inner side panel to the outer side panel.

[0008] In another aspect, the disclosure is generally directed to a carton for holding an article. The carton can comprise a plurality of panels that extends at least partially around an interior of the carton, the plurality of panels comprising a first panel, a second panel, and a third panel. An insert can comprise a central panel, an inner side panel foldably connected to the central panel, and an inner flap foldably connected to the inner side panel. The central panel can be at least partially secured to the first panel, the inner side panel can be spaced apart from the second panel, and the inner flap can be at least partially secured to the third panel.

[0009] Those skilled in the art will appreciate the above stated advantages and other advantages and benefits of various additional embodiments reading the following detailed description of the embodiments with reference to the below-listed drawing figures. It is within the scope of the present disclosure that the above-discussed aspects be provided both individually and in various combinations.

BRIEF DESCRIPTION OF THE DRAWINGS

- [0010] According to common practice, the various features of the drawings discussed below are not necessarily drawn to scale. Dimensions of various features and elements in the drawings may be expanded or reduced to more clearly illustrate the embodiments of the disclosure.
- [0011] Fig. 1 is a plan view of a carton blank used to form a carton according to a first exemplary embodiment of the disclosure.
- [0012] Fig. 2 is a plan view of an insert blank according to the first exemplary embodiment of the disclosure.
- [0013] Figs. 3 and 4 are perspective views of a partially formed carton and insert according to the first exemplary embodiment of the disclosure.
- [0014] Fig. 5A is a side view of the partially formed carton showing the insert and an article in phantom according to the first exemplary embodiment of the disclosure.
- [0015] Fig. 5B is a top perspective view of the partially formed carton of Fig. 5A showing the insert and the article in the interior of the carton.
- [0016] Figs. 6A and 6B are perspective views of the erected carton according to the first exemplary embodiment of the disclosure.
- [0017] Fig. 7 is a plan view of an insert blank according to a second exemplary embodiment of the disclosure.
- [0018] Fig. 8 is a plan view of an insert blank according to an alternative embodiment of the disclosure.
- [0019] Fig. 9 is a plan view of a blank used to form a carton according to a third exemplary embodiment of the disclosure.
- [0020] Corresponding parts are designated by corresponding reference numbers throughout the drawings.

DETAILED DESCRIPTION OF THE EXEMPLARY EMBODIMENTS

[0021] The present disclosure generally relates to cartons that contain an article or articles such as containers, bottles, cans, etc. The articles can be used for packaging food and beverage products, for example. The articles can be made from materials suitable in composition for packaging the particular food or beverage item, and the materials include, but are not limited to, aluminum and/or other metals; glass; aseptic bricks; paperboard; plastics such as PET, LDPE, LLDPE, HDPE, PP, PS, PVC, EVOH, and Nylon; and the like, or any combination thereof.

[0022] Cartons according to the present disclosure can accommodate articles of any shape. For the purpose of illustration and not for the purpose of limiting the scope of the disclosure, the following detailed description describes a beverage container (e.g., a glass bottle) as disposed within the carton embodiments. In this specification, the terms “inner,” “interior,” “outer,” “exterior,” “front,” “back,” “lower,” “bottom,” “upper,” and “top” indicate orientations determined in relation to fully erected and upright cartons.

[0023] Fig. 1 is a plan view of the interior side 1 of a carton blank, generally indicated at 3, used to form a carton 5 (Figs. 6A and 6B) according to the first exemplary embodiment of the disclosure. The carton 5 can be used to house an article such as a container C (Figs. 5A and 5B). In one embodiment, the container C generally can be a bottle (e.g., a wine or liquor bottle). Alternatively, the article could be any suitable shape and/or size. In the illustrated embodiment, the carton 5 is sized to house one container C, but it is understood that the carton 5 may be sized and shaped to hold containers of a different or same quantity in more than one layer and/or in different row/column arrangements (e.g., 1x2, 2x2, 1x6, 3x6, 2x6x2, 3x5, 4x5, 2x9, 2x6, 4x4, etc.). In the illustrated embodiment, the carton 5 includes a spacer insert 12 (Fig. 4) that reinforces and stabilizes the container in the carton and that can help retain the containers in a central portion of the interior of the carton, spaced apart from the sides of the carton.

[0024] The carton blank 3 has a longitudinal axis L1 and a lateral axis L2. The carton blank 3 can include a lateral centerline CT, as shown in Fig. 1. In the illustrated embodiment, the blank 3 comprises a back panel 15 foldably connected to a first side panel 17 at a first longitudinal fold line 19. A front panel 21 is foldably connected to the first side panel 17 at a second longitudinal fold line 23. A second side panel 25 is foldably connected to the back panel 15 at a third longitudinal fold line 27. An attachment flap 29 is foldably connected to the back panel 21 along a fourth longitudinal fold line 31. Any of the front panel 15, the back panel 21, the first and second side panels 17, 25, and the attachment flap 29 could be omitted or could be otherwise shaped, arranged, positioned, and/or configured without departing from the disclosure. For example, the attachment flap 29 could be foldably connected to the second side panel 25. In an alternative embodiment, the attachment flap 29

could be omitted, and the blank could include two panels (e.g., two front panels) that are overlapped when the carton is formed.

[0025] The back panel 15 is foldably connected to a first top end flap 33 and a first bottom end flap 35. The first side panel 17 is foldably connected to a second top end flap 37 and a second bottom end flap 39. The second side panel 25 is foldably connected to a third top end flap 41 and a third bottom end flap 43. The front panel 21 is foldably connected to a fourth bottom end flap 45. In the illustrated embodiment, a tuck-in flap 47 can be foldably connected to the first top panel 33 along a lateral fold line 48. When the carton 5 is erected, the top end flaps 33, 37, 41 close a top end 7 of the carton, and the bottom end flaps 35, 39, 43, 45 close a bottom end 9 of the carton. In accordance with an alternative embodiment of the present disclosure, different flap arrangements can be used for at least partially closing the ends 7, 9 of the carton 5.

[0026] In one embodiment, the top end flaps 33, 37, 41 extend along a first marginal area of the blank 3 and are foldably connected at a first lateral fold line 62 that extends along the width of the blank. In the illustrated embodiment, the bottom end flaps 35, 39, 43, 45 extend along a second marginal area of the blank 3 and are foldably connected at a second lateral fold line 64 that also extends along the width of the blank. The lateral fold lines 62, 64 may be, for example, substantially straight, or offset at one or more locations to account for blank thickness or for other factors. The lateral fold lines 62, 64 could be omitted or could be otherwise shaped, arranged, positioned, and/or configured without departing from the disclosure.

[0027] Fig. 2 illustrates an interior surface 101 of an insert blank 103 used to form the spacer insert 12 (Figs. 4, 5A, and 5B) for use in the carton 5 according to the exemplary embodiment of the disclosure. The insert blank 103 could be any suitable material (e.g., corrugated cardboard, paperboard, and/or other materials). In one embodiment, the insert blank 103 can be a different material than the carton blank 3. For example, the insert blank material could be a less expensive, uncoated, unprinted paperboard, and the carton blank material could be a relatively more expensive paperboard that is coated and/or printed on at least one side. The insert blank material and the carton blank material could be other suitable materials without departing from the disclosure. Additionally, the insert blank material and the carton blank material could be the same material without departing from the disclosure.

[0028] As shown in Fig. 2, the insert blank has a longitudinal axis L1 and a lateral axis L2. In the illustrated embodiment, the insert blank 103 includes a central panel 107, a first inner side panel 109 foldably connected to the central panel 107 along a longitudinal fold line 111, and a second inner side panel 113 foldably connected to the central panel 107 along a longitudinal fold line 115. In the illustrated embodiment, a first inner or end flap 127 is foldably connected to the first inner side panel

109 along a longitudinal fold line 129, and a second inner or end flap 131 is foldably connected to the second inner side panel 113 along a longitudinal fold line 133. As shown in Fig. 2, the first end flap 127 includes several tabs 135, interrupting the longitudinal fold line 129. The tabs 135 can be separable from the first inner side panel 109 along respective tear or cut lines 137 (e.g., generally U-shaped cut lines). Similarly, the second bottom flap 131 includes several tabs 139, which interrupt the longitudinal fold line 133. The tabs 139 can be separable from the second inner side panel 113 along respective tear or cut lines 141 (e.g., generally U-shaped cut lines). The tabs 135, 139 at the ends of the end flaps 127, 131 generally are shorter than the tabs extending along the middle portions of the end flaps 127, 131 in the illustrated embodiment. In an alternative embodiment, the insert blank 103 can include any suitable number of tabs 135, 139. The insert blank 103 could be omitted or could be otherwise shaped, arranged, positioned, and/or configured without departing from the disclosure. For example, one or more of the tabs 135, 139 could be replaced by openings or other features.

[0029] As shown in Figs. 3 and 4, in one exemplary embodiment, the carton 5 and insert 12 can be assembled from the carton blank 3 and the insert blank 103. In the illustrated embodiment, the carton 5 can be formed by folding the panels 15, 17, 21, 25 along the longitudinal fold lines 19, 23, 27, 31 and attaching the attachment flap 29 to the interior surface of the second side panel 25 (e.g., by gluing) to form an open-ended sleeve 150 (Figs. 3 and 4). In one embodiment, the glued attachment flap 29 and side panel 25 can generally cooperate to form the second side panel in the sleeve 150 and the carton 5. The sleeve 150 can be folded flat as shown in Fig. 3, or can be opened to form an interior 152 with the front panel 21 disposed opposite the back panel 15 and the side panels 17, 15 disposed opposite on another as shown in Fig. 4. The sleeve 150 could be otherwise formed without departing from the disclosure.

[0030] In one embodiment, the insert 12 can be formed by folding the insert blank 103 along longitudinal fold lines 111, 115, 129, 133 so that the inner side panels 109, 113 extend generally perpendicular with respect to the central panel 107 and the end flaps 127, 131 are generally perpendicular to the inner side panels 109, 113 (Fig. 4). In one embodiment, the end flap 127 can be folded along the fold line 129 so that the tabs 135 extend inwardly, and the end flap 131 can be folded along the fold line 133 so that the tabs 139 extend outwardly, as shown in Fig. 4. As shown in Fig. 4, the insert 12 can be inserted into the sleeve 150 so that the end flaps 127, 131 are in face-to-face contact with the front panel 21 and the central panel 107 is in face-to-face contact with the back panel 15. In one embodiment, the end flaps 127, 131 could be at least partially glued to the front panel 21 and/or the central panel 107 could be at least partially glued to the back panel 15 to help secure the insert 12 in the interior 152 of the open-ended sleeve 150 and the carton 5. In an alternative embodiment, the insert 12 could be otherwise oriented (e.g., the end flaps 127, 131 in face-to-face

contact with the back panel 15 or one of the side panels 17, 25) and/or the end flaps 127, 131 and/or the central panel 107 could be spaced apart from the panels 15, 17, 21, 25.

[0031] In one embodiment, the insert 12 could be formed along with the open-ended sleeve 150 (e.g., the end flaps 127, 131 could be glued in face-to-face contact with the front panel 21 of the blank 3, or the central panel 107 could be glued in face-to-face contact with the back panel 15, and the sleeve 150 could be formed around the insert 12). For example, the end flaps 127, 131 could be glued to the front panel 21 of the blank 3, and the blank could be folded along the longitudinal fold lines 19, 23, 27, 31 to position the back panel 15 in overlapping relationship with the central panel 107. In one embodiment, the central panel 107 is glued to the back panel 15. The attachment flap 29 can be glued to the interior surface of the second side panel 25 to form the open-ended sleeve 150 (Figs. 3 and 4). The open-ended sleeve 150 and/or the insert 12 could be otherwise formed without departing from the disclosure.

[0032] As shown in Figs. 4, 5A, and 5B, the inner side panels 109, 113 can be spaced apart from the side panels 17, 25. For example, the inner side panel 109 can be spaced apart from the side panel 17 by a distance D1 (e.g., approximately the distance between the fold line 129 and the outer edge 143 of the end flap 127), and the inner side panel 113 can be spaced apart from the side panel 25 by a distance D2 (e.g., approximately the distance between the fold line 133 and the outer edges 145 of the tabs 139). In the illustrated embodiment, the distances D1, D2 are generally equal. Alternatively, the distances D1, D2 could be different. As shown in Fig. 4, the outer edge 143 of the end flap 127 can be disposed adjacent the side panel 17, the outer edges 145 of the tabs 139 can be disposed adjacent the side panel 25 (e.g., the combination of the side panel 25 and the attachment flap 29), and the inner side panels 109, 113 can be generally parallel to the side panels 17, 25. In an alternative embodiment, the outer edges 143, 145 could be spaced apart from the side panels 17, 25 and/or the inner side panels 109, 113 could be oblique with respect to the side panels 17, 25 and/or the central panel 107. The insert 12 could be otherwise formed and/or inserted into the sleeve 150 without departing from the scope of the disclosure.

[0033] As shown in Fig. 3, the sleeve 150 and insert 12 can be collapsed into a flattened configuration, such as by folding the sleeve 150 along fold lines 19, 23, 27, 31 and the insert 12 along fold lines 111, 115, 129, 133. The flattened configuration can be convenient for storage and/or shipping of the carton 5. The carton 5 can be loaded with a container C by folding the open-ended sleeve 150 along fold lines 19, 23, 27, 31, 111, 115, 129, 133 to the opened configuration of Fig. 4 and closing the bottom end 9 (Figs. 5A and 6A). The bottom end 9 can be closed, in one embodiment, by folding the bottom end flaps 35, 39, 43, 45 along the fold line 64 to overlap and interlock the bottom end flaps (Fig. 6A). In one embodiment, the bottom end flaps could be glued together. As shown in Figs. 5A and 5B, a container C can be inserted into the interior 152 of the

sleeve 150 and the insert 12 through the open top end 7. Accordingly, as shown in Figs. 5A and 5B, the container C can be retained by at least the inner side panels 109, 113, the central panel 107, the front panel 21, and the closed bottom end 9, wherein the side panels 17, 25 are spaced apart from the inner side panels 109, 113 and the container C by the respective distances D1, D2.

[0034] As shown in Fig. 6B, the top end 7 can be closed by folding the top end flaps 37, 41 along the fold line 62, and folding the top end flap 33 along the fold line 62 to overlap the top end flaps 37, 41. In the illustrated embodiment, the tuck-in flap 47 can be folded along the fold line 48 and inserted into the interior 152 of the sleeve 150 between the front panel 21 and the top end flaps 37, 41. The carton 5 could be loaded and/or the ends 7, 9 could be closed by other steps without departing from the disclosure. Additionally, other closing and loading sequences can be used without departing from the disclosure.

[0035] The erected carton 5 according to the illustrated embodiment is shown in Figs. 5A and 5B. The insert 12 can retain the container C in the carton 5 while the outer carton is larger than the container (e.g., the side panels 17, 25 are wider than the bottle). Accordingly, an outer carton that is larger than the container can be used for a larger presence on a store shelf or for larger surface for printed material, for example, while the insert 12 retains the container C in the interior 152 of the carton 5.

[0036] Fig. 7 is a plan view of an insert blank 303 for forming an insert (not shown) according to a second embodiment of the disclosure. The second embodiment is generally similar to the first embodiment, except for variations noted and variations that will be apparent to one of ordinary skill in the art. Accordingly, similar or identical features of the embodiments have been given like or similar reference numbers. As shown in Fig. 7, the insert blank 303 is generally similar to the insert blank 103 of the first embodiment, except the insert blank 303 has a slightly different shape. For example, the first end flap 327 has a different shape than the first end flap 127 of the first embodiment. Additionally, the second end flap 331 as shown in Fig. 7 is similar to the second end flap 131 of the first embodiment, except that the tabs 339 of the second end flap 331 extend adjacent respective openings 342 (e.g., the tabs 339 are spaced from a portion of the second inner side panel 113 by the openings 342). The insert blank 303 could be otherwise shaped, arranged, positioned, and/or configured without departing from the disclosure. For example, in an alternative embodiment shown in Fig. 8, the insert blank 303' can be generally similar to the insert blank 303 except that the end flaps 327', 331' and the openings 342' can have generally different shapes than the end flaps 327, 331 and the openings 342 of Fig. 7.

[0037] Fig. 9 is a plan view of a blank 403 for forming carton with an integrated spacing feature (not shown) according to a third embodiment of the disclosure showing exemplary dimensions. The third embodiment is generally similar to the first embodiment, except for variations noted and variations that will be apparent to one of ordinary skill in the art. Accordingly, similar or identical features of the embodiments have been given like or similar reference numbers. As shown in Fig. 9, the blank 403 has a first (e.g., outer) portion 404 and a second (e.g., inner) portion 406. In the illustrated embodiment, the outer portion 404 is generally the same as the carton blank 3 of the first embodiment without the attachment flap 29. Accordingly, the outer portion 404 forms an outer carton (not shown) similar to the outer carton 5 of the first embodiment. The inner portion 406 is generally the same as the insert blank 303 of the second embodiment and forms an integrated spacing feature (not shown) in the interior of the outer carton formed by the outer portion 404. The integrated spacing feature can be generally similar to the insert 12 of the first embodiment (e.g., Figs. 4, 5A, and 5B). In the illustrated embodiment, the end flap 527 of the inner portion 406 is foldably connected to the second side panel 425 of the outer portion 404 along a longitudinal fold line 449. In one embodiment, the outer portion 404 could be considered a carton blank and the inner portion 406 could be considered an insert blank, wherein the insert blank is foldably connected to the carton blank along a fold line (e.g., fold line 449). The blank 403 could be otherwise shaped, arranged, and/or configured without departing from the disclosure. For example, the inner portion 406 could be foldably connected to the front panel 21 in an alternative embodiment.

[0038] In one embodiment, a carton with an integrated spacing feature (not shown) can be formed by the blank 403 by folding the blank along the longitudinal fold line 449 so that the inner portion 406 is in face-to-face contact with the outer portion 404. In one embodiment, the central panel 107 can be glued to the back panel 15. The blank can be folded along the longitudinal fold lines 19, 23, 27, 111, 115, 129, 133 and the end flaps 331, 527 can be glued in face-to-face contact with the front panel 21 to form an open-ended sleeve (not shown) with the inner portion 406 disposed within the outer portion 404. The sleeve can look similar to the sleeve 150 of the first embodiment shown in Fig. 4 except that the attachment flap 29 is omitted and the end flap 527 is foldably connected to the second side panel 425. Additionally, the integrated spacing feature would have an opposite orientation than the insert 12 of the first embodiment shown in Fig. 4 so that the inner side panel 109 is proximate the second side panel 425 and the inner side panel 113 is proximate the first side panel 17. The carton could be loaded and closed as shown in described in the first embodiment. The carton could be formed, loaded, and/or closed by other steps without departing from the disclosure. Additionally, other forming, closing, and/or loading sequences can be used without departing from the disclosure.

[0039] Any of the features of the various embodiments of the disclosure can be combined with, replaced by, or otherwise configured with other features of other embodiments of the disclosure without departing from the scope of this disclosure. Further, it is noted that the reinforcing inserts and insert blanks of the various embodiments can be incorporated into a carton having any carton style or panel configuration. The carton styles and panel configurations described above are included by way of example.

[0040] The blanks according to the present disclosure can be, for example, formed from coated paperboard and similar materials. For example, the interior and/or exterior sides of the blanks can be coated with a clay coating. The clay coating may then be printed over with product, advertising, price coding, and other information or images. The blanks may then be coated with a varnish to protect any information printed on the blank. The blanks may also be coated with, for example, a moisture barrier layer, on either or both sides of the blank. In accordance with the above-described embodiments, the blanks may be constructed of paperboard of a caliper such that it is heavier and more rigid than ordinary paper. The blanks can also be constructed of other materials, such as cardboard, hard paper, or any other material having properties suitable for enabling the carton to function at least generally as described herein. The blanks can also be laminated or coated with one or more sheet-like materials at selected panels or panel sections.

[0041] In accordance with the above-described embodiments of the present disclosure, a fold line can be any substantially linear, although not necessarily straight, form of weakening that facilitates folding therealong. More specifically, but not for the purpose of narrowing the scope of the present disclosure, fold lines include: a score line, such as lines formed with a blunt scoring knife, or the like, which creates a crushed portion in the material along the desired line of weakness; a cut that extends partially into a material along the desired line of weakness, and/or a series of cuts that extend partially into and/or completely through the material along the desired line of weakness; and various combinations of these features.

[0042] As an example, a tear line can include: a slit that extends partially into the material along the desired line of weakness, and/or a series of spaced apart slits that extend partially into and/or completely through the material along the desired line of weakness, or various combinations of these features. As a more specific example, one type tear line is in the form of a series of spaced apart slits that extend completely through the material, with adjacent slits being spaced apart slightly so that a nick (e.g., a small somewhat bridging-like piece of the material) is defined between the adjacent slits for typically temporarily connecting the material across the tear line. The nicks are broken during tearing along the tear line. The nicks typically are a relatively small percentage of the tear line, and alternatively the nicks can be omitted from or torn in a tear line such that the tear line is a continuous cut line. That is, it is within the scope of the present disclosure for each of the tear lines to be

replaced with a continuous slit, or the like. For example, a cut line can be a continuous slit or could be wider than a slit without departing from the present disclosure.

[0043] The above embodiments may be described as having one or more panels adhered together by glue during erection of the carton embodiments. The term “glue” is intended to encompass all manner of adhesives commonly used to secure carton panels in place.

[0044] The foregoing description of the disclosure illustrates and describes various embodiments. As various changes could be made in the above construction without departing from the scope of the disclosure, it is intended that all matter contained in the above description or shown in the accompanying drawings shall be interpreted as illustrative and not in a limiting sense. Furthermore, the scope of the present disclosure covers various modifications, combinations, alterations, etc., of the above-described embodiments that are within the scope of the claims. Additionally, the disclosure shows and describes only selected embodiments of the disclosure, but the disclosure is capable of use in various other combinations, modifications, and environments and is capable of changes or modifications within the scope of the inventive concept as expressed herein, commensurate with the above teachings, and/or within the skill or knowledge of the relevant art. Furthermore, certain features and characteristics of each embodiment may be selectively interchanged and applied to other illustrated and non-illustrated embodiments of the disclosure.

WHAT IS CLAIMED IS:

1. A carton for holding an article, the carton comprising:
 - a plurality of panels that extends at least partially around an interior of the carton, the plurality of panels comprising a first panel and a second panel; and
 - an insert comprising a central panel, an inner side panel foldably connected to the central panel, and an inner flap foldably connected to the inner side panel, wherein the first panel at least partially overlaps the central panel, the inner side panel is spaced apart from the second panel, and at least a portion of the inner flap extends from the inner side panel to the second panel.
2. The carton of claim 1, wherein at least a portion of the inner flap extends inwardly from the inner side panel.
3. The carton of claim 1, wherein the inner flap is foldably connected to the inner side panel along a fold line and comprises a tab, the tab interrupts the fold line, and an edge of the tab extends from respective ends of the fold line.
4. The carton of claim 3, wherein the tab extends from the fold line to the second panel.
5. The carton of claim 3, wherein the tab extends inwardly from the fold line with respect to the inner side panel.
6. The carton of claim 3, wherein the plurality of panels comprises a third panel disposed generally opposite to the first panel, and the inner flap and the tab are at least partially in face-to-face contact with the third panel.
7. The carton of claim 3, wherein the tab is a first tab, and the insert comprises a second tab extending from the inner flap.
8. The carton of claim 1, wherein:
 - the plurality of panels further comprises a third panel disposed generally opposite to the second panel;
 - the inner side panel is a first inner side panel, and the inner flap is a first inner flap; and
 - the insert further comprises a second inner side panel foldably connected to the central panel and a second inner flap foldably connected to the second inner side panel, at least a portion of the second inner flap extending from the second inner side panel to the third panel.

9. The carton of claim 8, wherein at least a portion of each of the first inner flap and the second inner flap extends inwardly with respect to the respective first inner side panel and second inner side panel.
10. The carton of claim 8, wherein the first inner flap is foldably connected to the first inner side panel along a first fold line and comprises a first tab interrupting the first fold line, the second inner flap is foldably connected to the second inner side panel along a second fold line and comprises a second tab interrupting the second fold line.
11. The carton of claim 10, wherein the first tab extends inwardly with respect to the first inner side panel, and the second tab extends from the second inner side panel to the third panel.
12. The carton of claim 11, wherein the first inner flap comprises a first outer edge disposed opposite to the first tab, the second tab comprises a second outer edge, and the first outer edge and the second outer edge engage the respective second panel and third panel.
13. The carton of claim 8, wherein the plurality of panels further comprises a fourth panel disposed generally opposite to the first panel, and each of the first inner flap and the second inner flap is disposed at least partially in face-to-face contact with the fourth panel.
14. The carton of claim 8, wherein the plurality of panels further comprises a fourth panel disposed generally opposite to the first panel, and the carton is for at least partially receiving the article so that the article is at least partially retained by the fourth panel, the central panel, the first inner side panel, and the second inner side panel.
15. The carton of claim 1, wherein the plurality of panels comprises a third panel disposed generally opposite to the first panel, and the inner flap is at least partially in face-to-face contact with the third panel.
16. The carton of claim 15, wherein the central panel is at least partially in face-to-face contact with the first panel.
17. The carton of claim 15, wherein an outer edge of the inner flap is disposed adjacent the second panel.
18. The carton of claim 1, further comprising at least one end flap foldably connected to a respective panel of the plurality of panels, the at least one end flap at least partially forming an at least partially closed end of the carton.

19. The carton of claim 18, wherein the carton is for at least partially receiving the article so that the article is at least partially retained by the closed end of the carton, the central panel, and the first inner side panel.

20. The carton of claim 1, wherein the first panel is foldably connected to the second panel along a first fold line, and the inner flap is foldably connected to the second panel along a second fold line.

21. In combination, a carton blank and an insert blank for forming a carton for holding an article:

the carton blank comprising a plurality of panels comprising a first panel and a second panel;

and

the insert blank comprising a central panel, an inner side panel foldably connected to the central panel, and an inner flap foldably connected to the inner side panel, wherein the first panel is for at least partially overlapping the central panel when the carton is formed from the carton blank and the insert blank, and the inner side panel is for being spaced apart from the second panel and at least a portion of the inner flap is for extending from the inner side panel to the second panel when the carton is formed from the carton blank and the insert blank.

22. The combination of claim 21, wherein the inner flap is foldably connected to the inner side panel along a fold line and comprises a tab, the tab interrupts the fold line and is at least partially defined by a cut line extending from respective ends of the fold line.

23. The combination of claim 22, wherein the tab is at least partially separable from the inner side panel along the cut line.

24. The combination of claim 22, wherein the plurality of panels comprises a third panel for being disposed generally opposite to the first panel when the carton is formed from the carton blank and the insert blank, and the inner flap and the tab are for being disposed at least partially in face-to-face contact with the third panel when the carton is formed from the carton blank and the insert blank.

25. The combination of claim 22, wherein the tab is a first tab, and the insert comprises a second tab extending from the inner flap.

26. The combination of claim 21, wherein:

the plurality of panels further comprises a third panel for being disposed generally opposite to the second panel when the carton is formed from the carton blank and the insert blank;

the inner side panel is a first inner side panel, and the inner flap is a first inner flap; and

the insert further comprises a second inner side panel foldably connected to the central panel and a second inner flap foldably connected to the second inner side panel, at least a portion of the second inner flap being for extending from the second inner side panel to the third panel when the carton is formed from the carton blank and the insert blank.

27. The combination of claim 26, wherein the first inner flap is foldably connected to the first inner side panel along a first fold line and comprises a first tab interrupting the first fold line, the second inner flap is foldably connected to the second inner side panel along a second fold line and comprises a second tab interrupting the second fold line.

28. The combination of claim 27, wherein the first tab is at least partially separable from the first inner side panel along a first cut line extending from respective ends of the first fold line, and the second tab is at least partially separable from the second inner side panel along a second cut line extending from respective ends of the second fold line.

29. The combination of claim 26, wherein the plurality of panels further comprises a fourth panel for being disposed generally opposite to the first panel when the carton is formed from the carton blank and the insert blank, and each of the first inner flap and the second inner flap is for being disposed at least partially in face-to-face contact with the fourth panel when the carton is formed from the carton blank and the insert blank.

30. The combination of claim 21, further comprising at least one end flap foldably connected to a respective panel of the plurality of panels, the at least one end flap being for at least partially forming an at least partially closed end of the carton formed from the carton blank and the insert blank.

31. The combination of claim 21, wherein the first panel is foldably connected to the second panel along a first fold line, the central panel is foldably connected to the inner side panel along a second fold line, and the inner flap is foldably connected to the inner side panel along a third fold line.

32. A blank for forming a carton for holding an article, the blank comprising:
a first portion comprising a plurality of panels comprising a first panel and a second panel;
and
a second portion for forming an inner spacer feature in the carton formed from the blank, the second portion comprising a central panel, an inner side panel foldably connected to the central panel, and an inner flap foldably connected to the inner side panel, wherein the first panel is for at least partially overlapping the central panel when the carton is formed from the blank, and the inner side panel is for being spaced apart from the second panel and at least a portion of the inner flap is for extending from the inner side panel to the second panel when the carton is formed from the blank.
33. The blank of claim 32, wherein the inner flap is foldably connected to the second panel along a fold line.
34. The blank of claim 32, wherein the first panel is foldably connected to the second panel along a first fold line, and the second panel is foldably connected to the inner flap along a second fold line.
35. The blank of claim 34, wherein the plurality of panels further comprises a third panel foldably connected to the first panel along a third fold line and a fourth panel foldably connected to the third panel along a fourth fold line.
36. The blank of claim 34, wherein the inner side panel is foldably connected to the inner flap along a third fold line, and the central panel is foldably connected to the inner side panel along a fourth fold line.
37. The blank of claim 32, wherein inner flap is foldably connected to the second panel along a first fold line and is foldably connected to the inner side panel along a second fold line, and the inner flap comprises a plurality of tabs, each tab being at least partially separable from the inner side panel along a respective cut line.
38. A method of forming a carton for holding an article, the method comprises:
obtaining a carton blank and an insert blank, the carton blank comprising a plurality of panels comprising a first panel and a second panel, and the insert blank comprising a central panel, an inner side panel foldably connected to the central panel, and an inner flap foldably connected to the inner side panel;
forming an interior of the carton at least partially defined by the plurality of panels of the carton blank, the forming the interior of the carton comprising forming an open-ended sleeve; and

forming an insert from the insert blank, wherein the first panel at least partially overlaps the central panel, the inner side panel is spaced apart from the outer side panel, and at least a portion of the inner flap extends from the inner side panel to the outer side panel.

39. The method of claim 38, wherein the forming the insert comprises folding the inner side panel relative to the central panel, folding the inner flap relative to the inner side panel, and positioning the insert in the interior of the carton.

40. The method of claim 38, wherein the plurality of panels further comprise a third panel, and the method further comprises at least partially attaching the inner flap to the third panel before the forming the open-ended sleeve, the forming the open-ended sleeve comprises positioning the third panel to be generally opposite to the first panel, and the forming the insert comprising folding the inner flap, the inner side panel, and the central panel relative to one another as the open-ended sleeve is formed.

41. The method of claim 40, wherein the inner side panel is a first inner side panel, the inner flap is a first inner flap, the insert blank comprises a second inner side panel foldably connected to the central panel and a second inner flap foldably connected to the second inner side panel, and the method further comprises at least partially attaching the second inner flap to the third panel before the forming the open-ended sleeve.

42. The method of claim 40, wherein the forming the open-ended sleeve comprises folding the carton blank to position the first panel at least partially in face-to-face contact with the central panel, at least partially attaching the first panel to the central panel, and folding the insert blank and the carton blank to position the central panel and the first panel generally opposite to the inner flap and the third panel.

43. A carton for holding an article, the carton comprising:

a plurality of panels that extends at least partially around an interior of the carton, the plurality of panels comprising a first panel, a second panel, and a third panel; and

an insert comprising a central panel, an inner side panel foldably connected to the central panel, and an inner flap foldably connected to the inner side panel, wherein the central panel is at least partially secured to the first panel, the inner side panel is spaced apart from the second panel, and the inner flap is at least partially secured to the third panel proximate the second panel.

44. The carton of claim 43, wherein the second panel extends from the first panel to the third panel, and the third panel is disposed opposite to the first panel.

45. The carton of claim 43, wherein the inner flap is foldably connected to the inner side panel along a fold line and comprises a tab interrupting the fold line.

46. The carton of claim 45, wherein the tab extends from the fold line toward the second panel.

47. The carton of claim 45, wherein the tab extends inwardly from the fold line with respect to the inner side panel and a portion of the inner flap extends from the inner side panel toward the second panel.

48. The carton of claim 43, wherein:

the plurality of panels further comprises a fourth panel disposed generally opposite to the second panel;

the inner side panel is a first inner side panel, and the inner flap is a first inner flap;

the insert further comprises a second inner side panel foldably connected to the central panel and a second inner flap foldably connected to the second inner side panel; and

the second inner side panel is spaced apart from the fourth panel, and the second inner flap is at least partially secured to the third panel proximate the fourth panel.

49. The carton of claim 48, wherein the first inner flap comprises a first plurality of tabs, and the second inner flap comprises a second plurality of tabs.

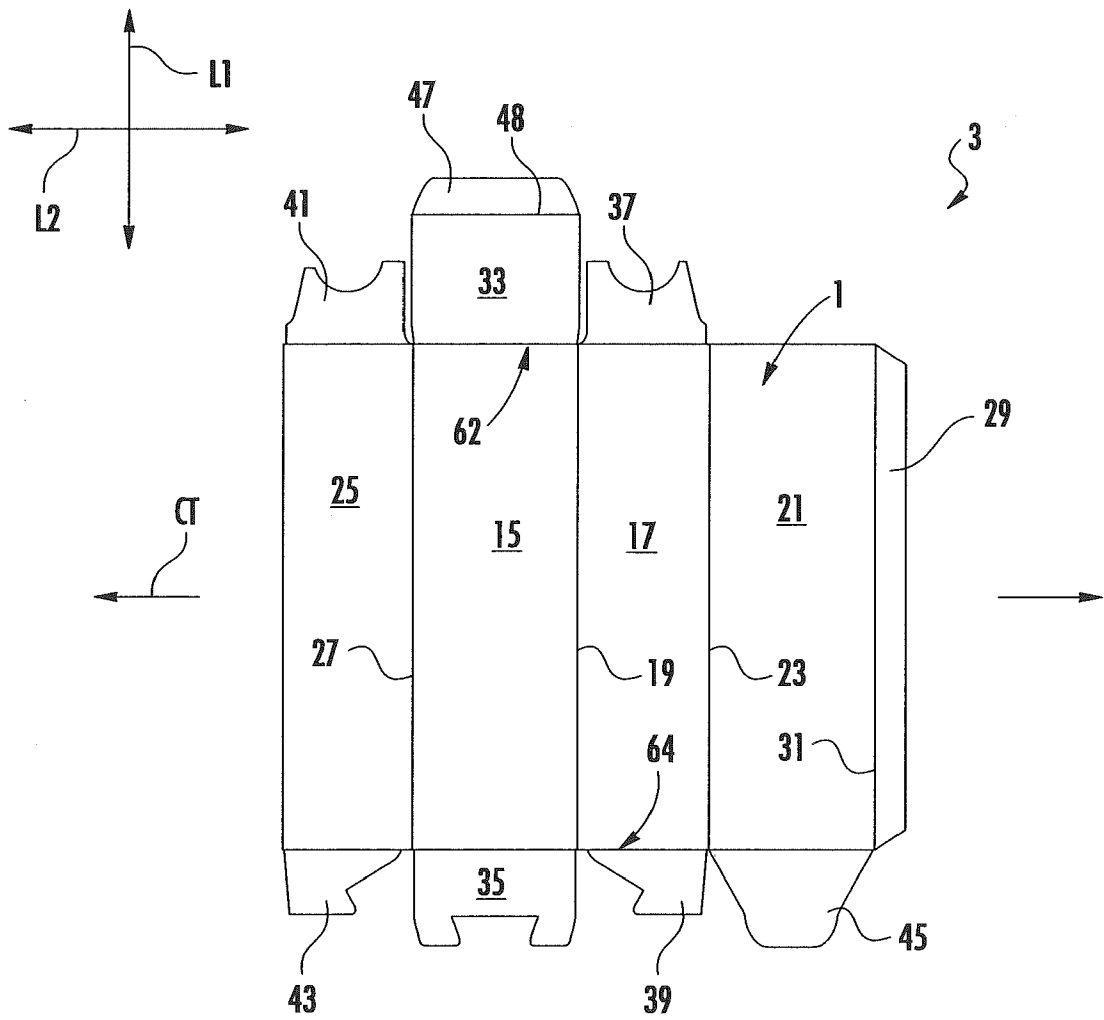

FIG. 1

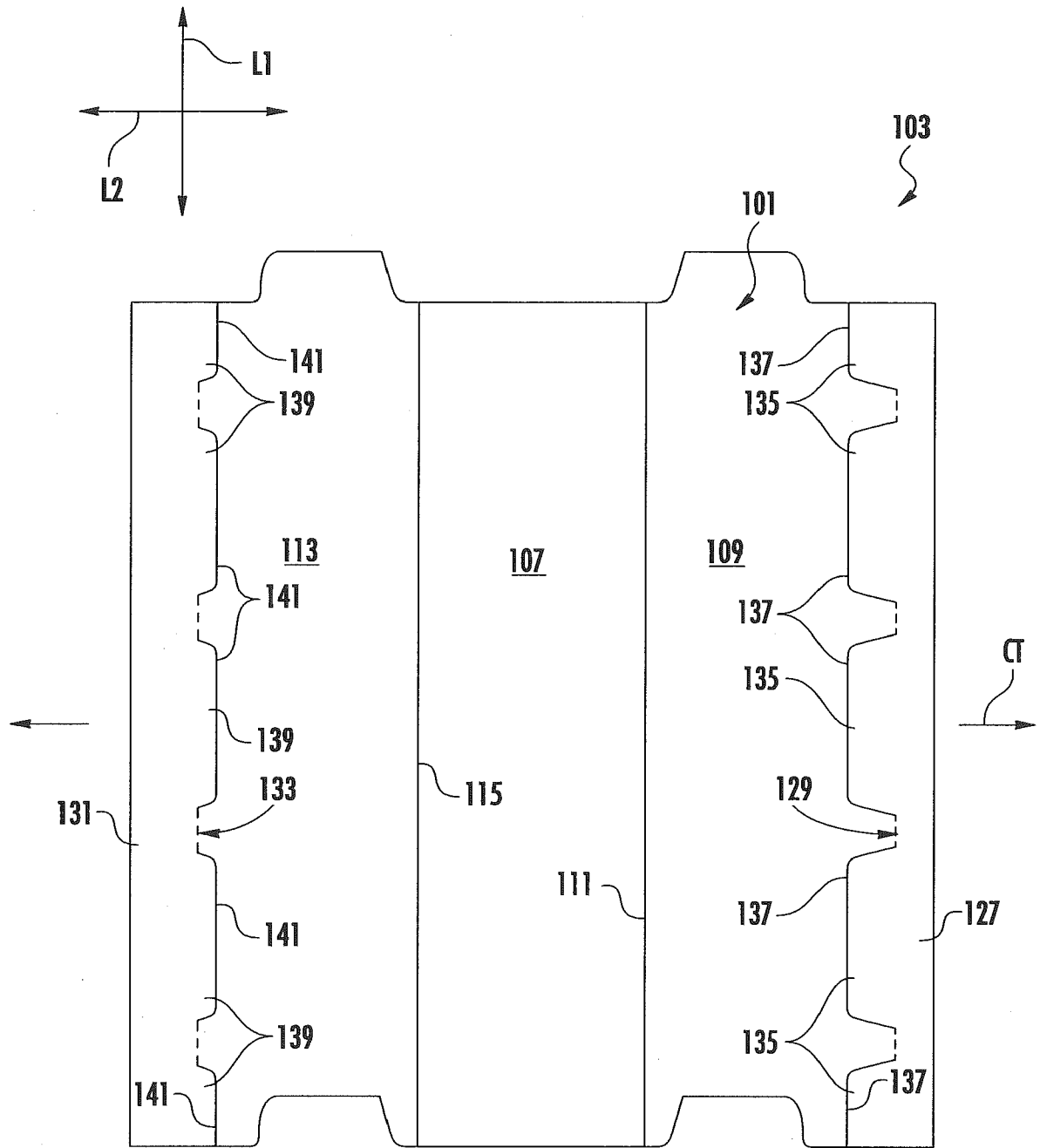
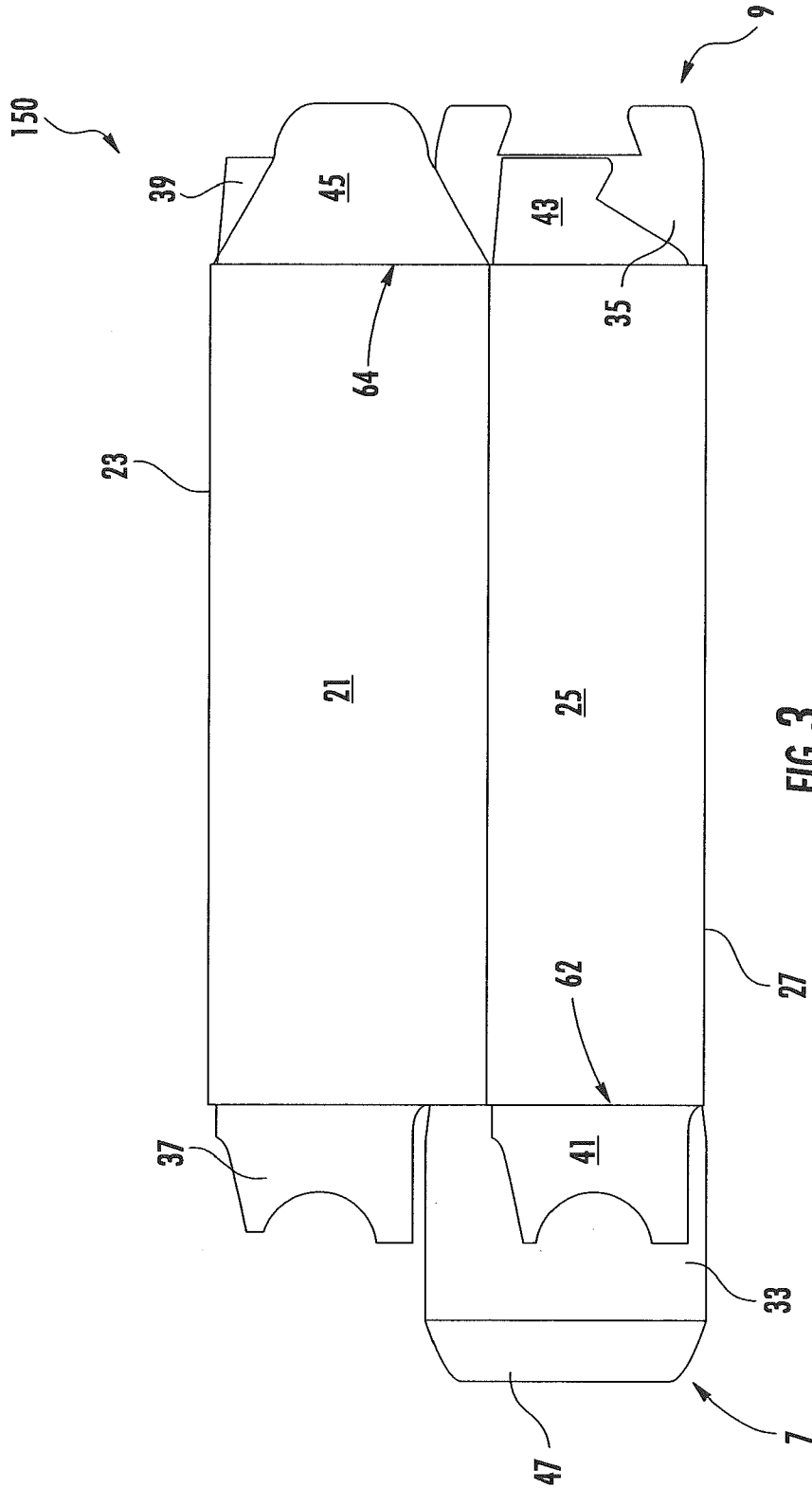

FIG. 2



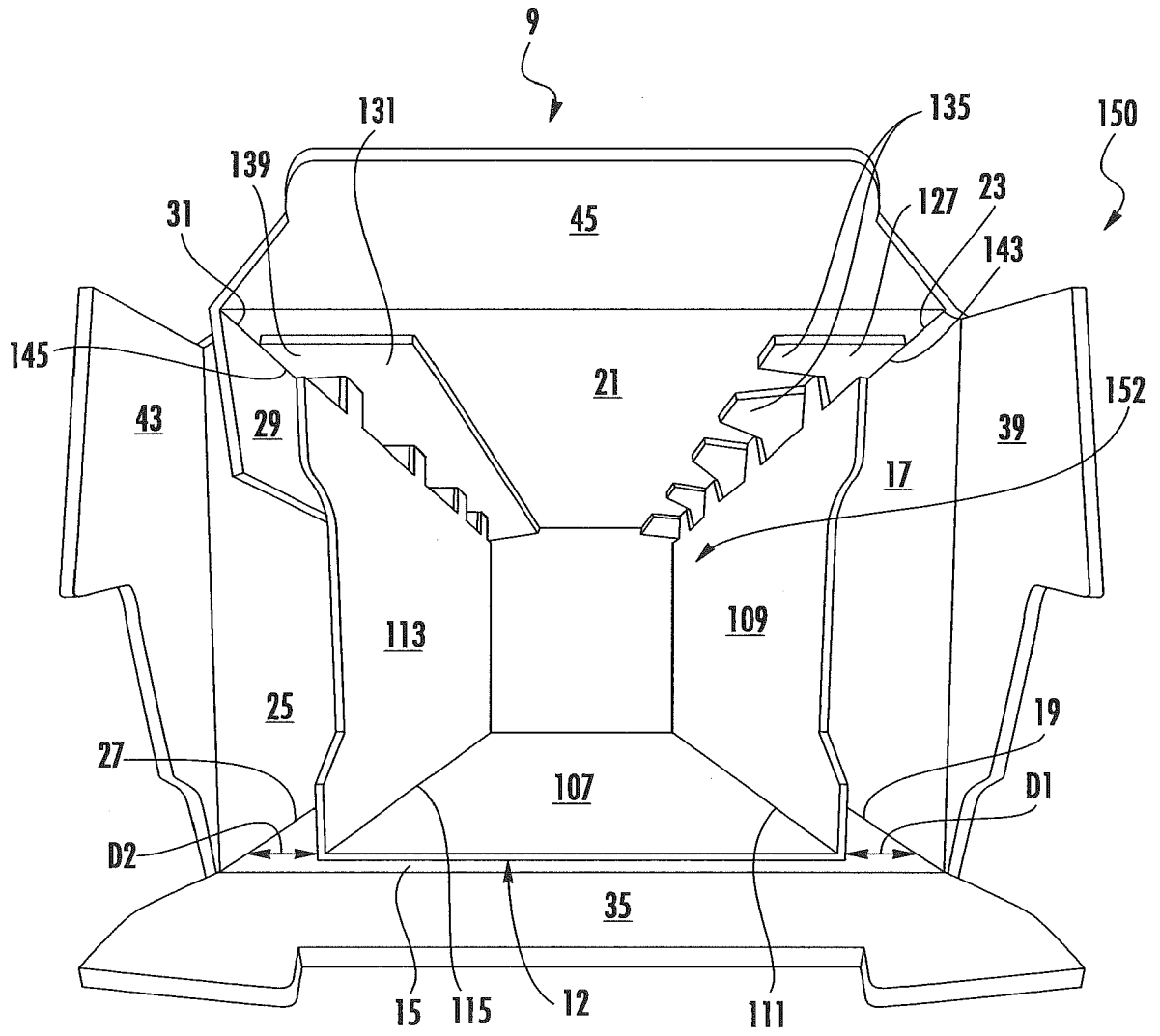

FIG. 4

5/10

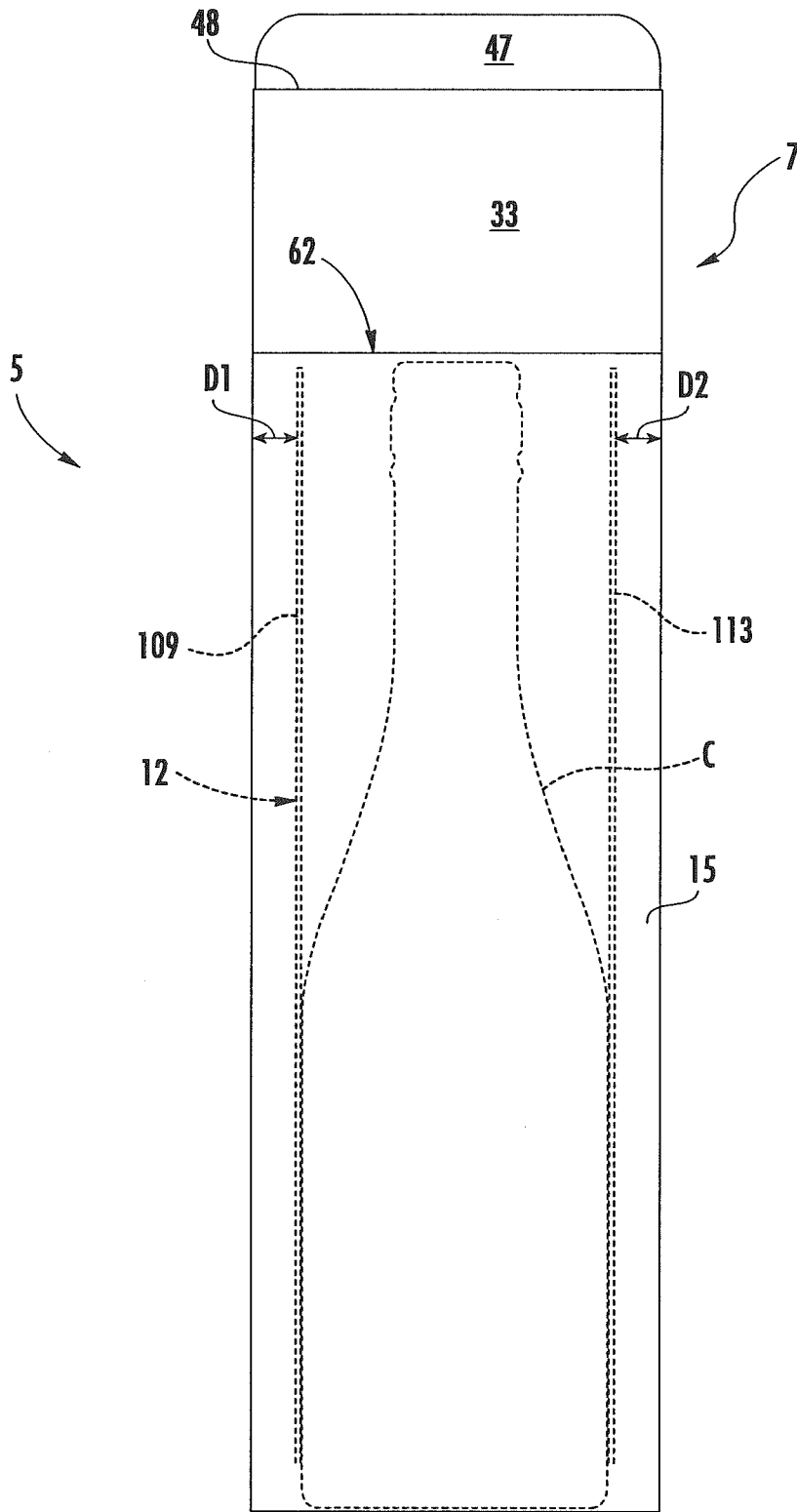

FIG. 5A

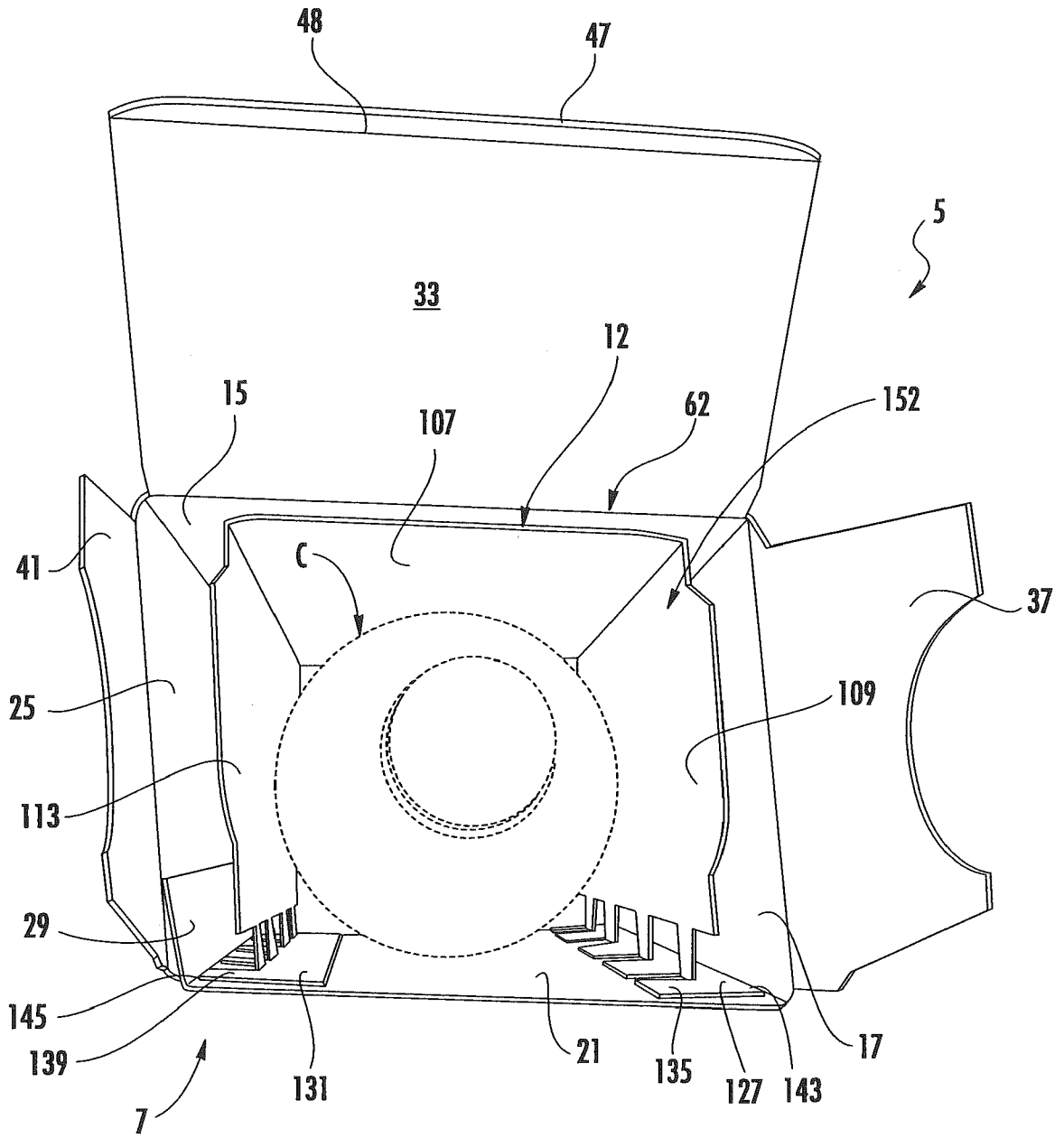

FIG. 5B

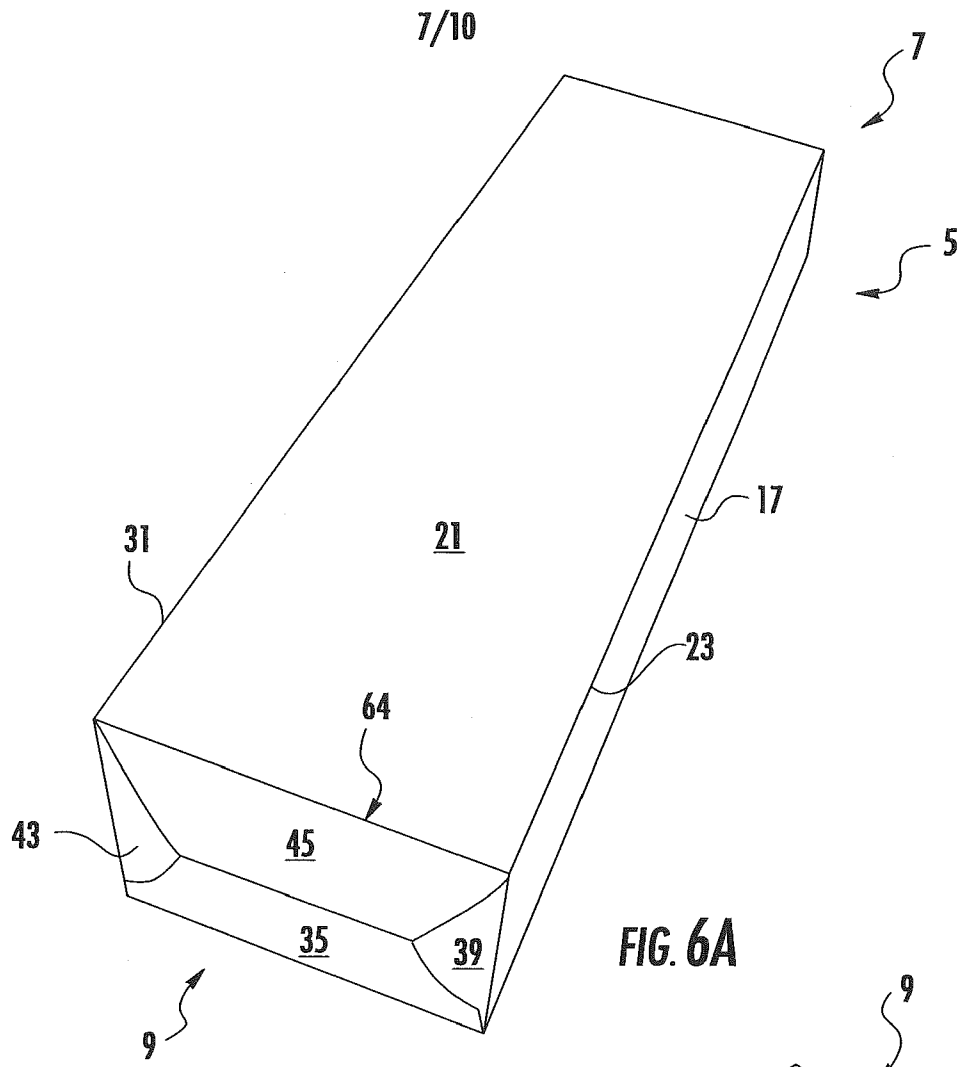

FIG. 6A

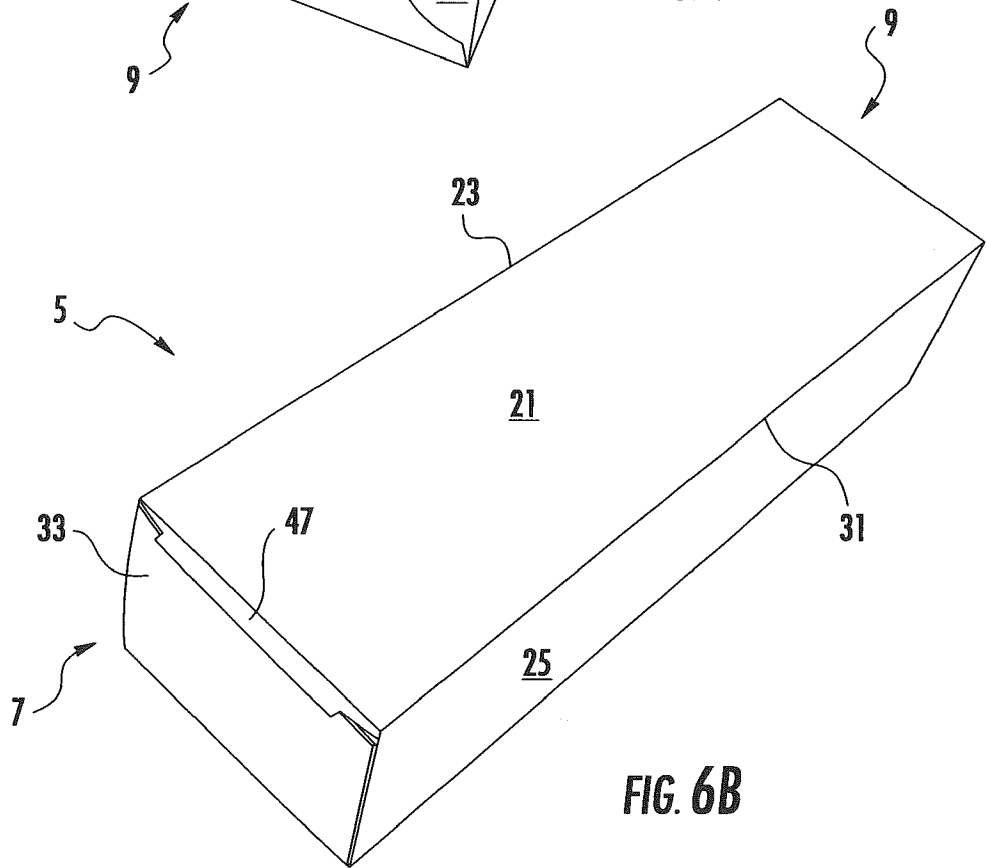

FIG. 6B

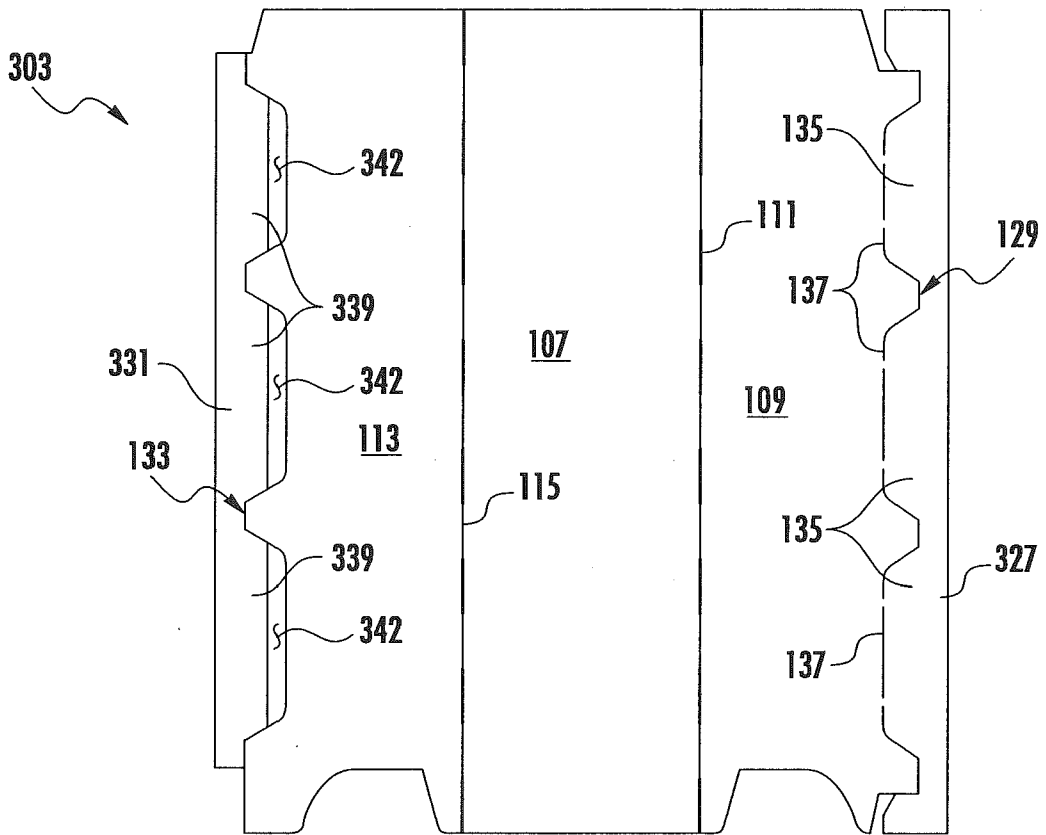

FIG. 7

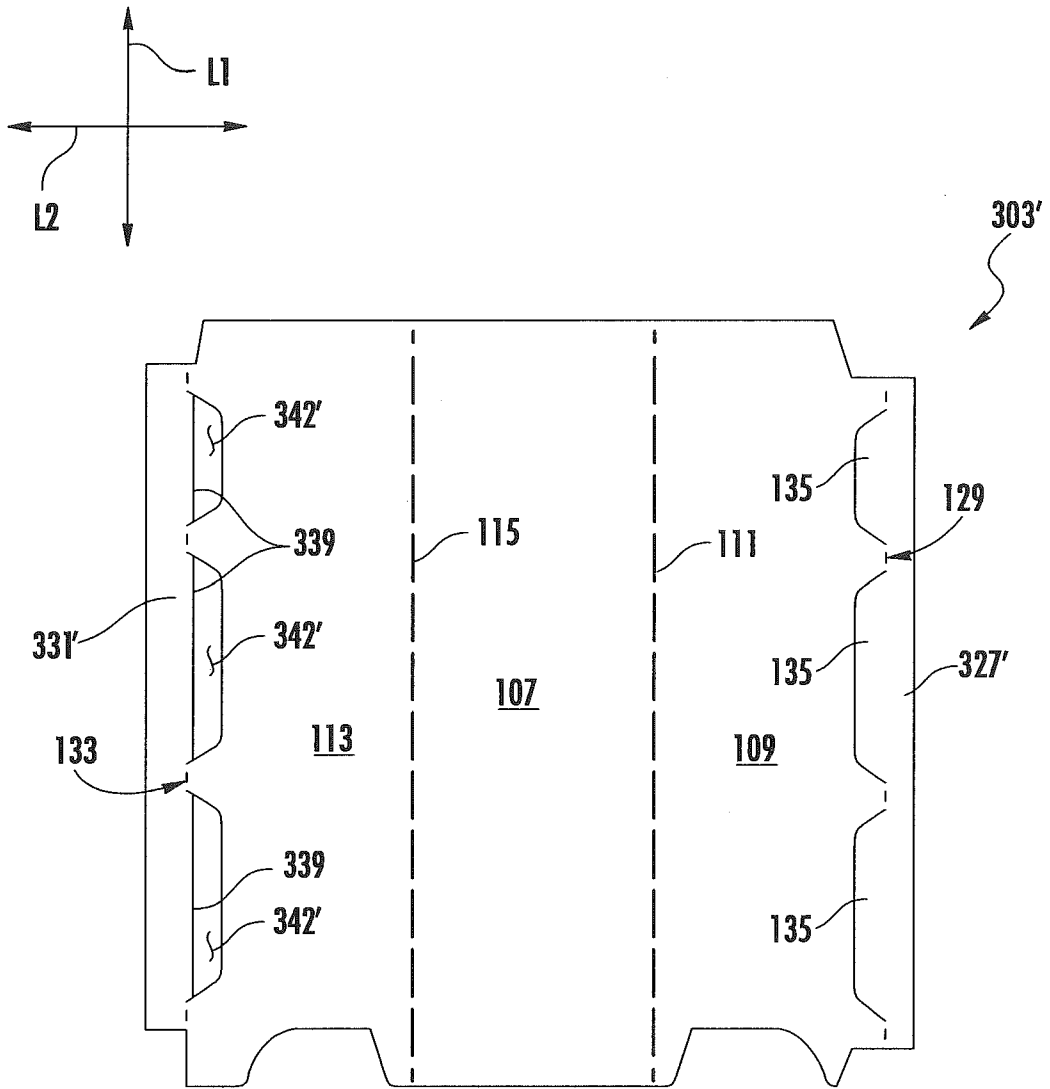

FIG. 8

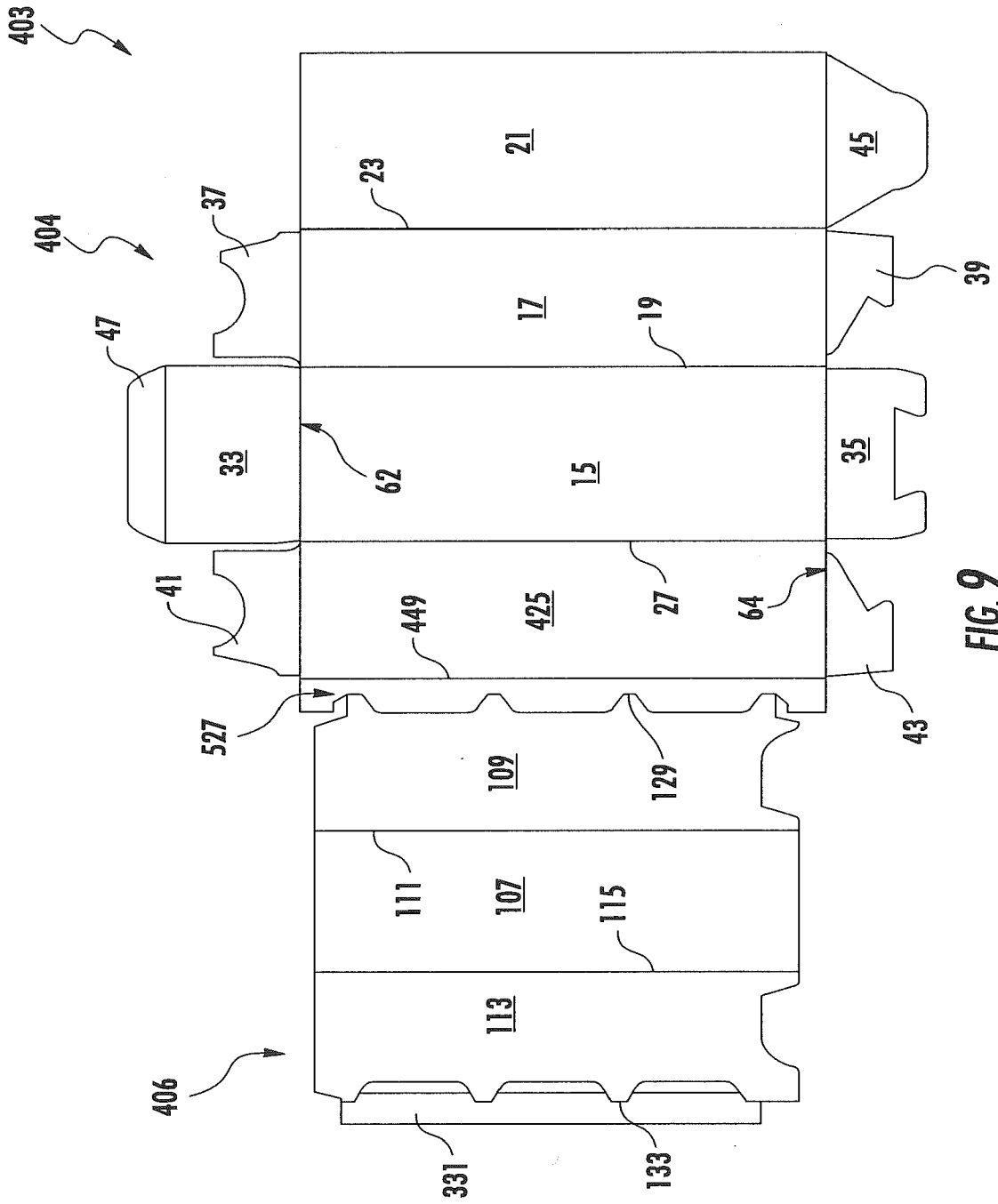

FIG. 9

INTERNATIONAL SEARCH REPORT

International application No.
PCT/US2015/019838**A. CLASSIFICATION OF SUBJECT MATTER****B65D 5/50(2006.01)i, B65D 81/05(2006.01)i**

According to International Patent Classification (IPC) or to both national classification and IPC

B. FIELDS SEARCHED

Minimum documentation searched (classification system followed by classification symbols)

B65D 5/50; B65D 5/44; B65D 5/52; B65D 81/02; B65D 5/02; B65D 85/30; B65D 77/26; B65D 85/20; B65D 81/05

Documentation searched other than minimum documentation to the extent that such documents are included in the fields searched

Korean utility models and applications for utility models
Japanese utility models and applications for utility models

Electronic data base consulted during the international search (name of data base and, where practicable, search terms used)

eKOMPASS(KIPO internal) & Keywords: carton, insert, panel, flap, tab, edge and fold

C. DOCUMENTS CONSIDERED TO BE RELEVANT

Category*	Citation of document, with indication, where appropriate, of the relevant passages	Relevant to claim No.
X	KR 10-1039192 B1 (HANJIN P&C CO., LTD.) 03 June 2011 See paragraphs [0016]-[0030] and figures 1, 8-9.	1-39,43-49
A		40-42
A	JP 2004-142775 A (TAKAHASHI SUISAN K.K. et al.) 20 May 2004 See paragraphs [0012]-[0031] and figures 1-7.	1-49
A	JP 2006-240683 A (DAINIPPON PRINTING CO., LTD.) 14 September 2006 See paragraphs [0011]-[0023] and figures 1-6.	1-49
A	KR 10-2011-0096657 A (KIM, JOOYOUNG) 31 August 2011 See paragraphs [0022]-[0026] and figures 1-7.	1-49
A	US 2006-0042983 A1 (LIU et al.) 02 March 2006 See paragraphs [0009]-[0017] and figures 1-11.	1-49

 Further documents are listed in the continuation of Box C. See patent family annex.

* Special categories of cited documents:

"A" document defining the general state of the art which is not considered to be of particular relevance

"E" earlier application or patent but published on or after the international filing date

"L" document which may throw doubts on priority claim(s) or which is cited to establish the publication date of another citation or other special reason (as specified)

"O" document referring to an oral disclosure, use, exhibition or other means

"P" document published prior to the international filing date but later than the priority date claimed

"T" later document published after the international filing date or priority date and not in conflict with the application but cited to understand the principle or theory underlying the invention

"X" document of particular relevance; the claimed invention cannot be considered novel or cannot be considered to involve an inventive step when the document is taken alone

"Y" document of particular relevance; the claimed invention cannot be considered to involve an inventive step when the document is combined with one or more other such documents, such combination being obvious to a person skilled in the art

"&" document member of the same patent family

Date of the actual completion of the international search

25 June 2015 (25.06.2015)

Date of mailing of the international search report

25 June 2015 (25.06.2015)

Name and mailing address of the ISA/KR

International Application Division
Korean Intellectual Property Office
189 Cheongsa-ro, Seo-gu, Daejeon Metropolitan City, 302-701,
Republic of Korea

Facsimile No. +82-42-472-7140

Authorized officer

KIM, Jin Ho

Telephone No. +82-42-481-8699



INTERNATIONAL SEARCH REPORT

Information on patent family members

International application No.

PCT/US2015/019838

Patent document cited in search report	Publication date	Patent family member(s)	Publication date
KR 10-1039192 B1	03/06/2011	KR 10-2010-0098783 A	10/09/2010
JP 2004-142775 A	20/05/2004	None	
JP 2006-240683 A	14/09/2006	JP 4620499 B2	26/01/2011
KR 10-2011-0096657 A	31/08/2011	None	
US 2006-0042983 A1	02/03/2006	AU 2005-317180 A1	22/06/2006
		CN 101124129 A	13/02/2008
		CN 101124129 B	04/08/2010
		EP 1896345 A2	12/03/2008
		EP 1896345 A4	26/08/2009
		JP 2008-524081 A	10/07/2008
		US 7258235 B2	21/08/2007
		WO 2006-065876 A2	22/06/2006
		WO 2006-065876 A3	12/10/2006