

(19)



(11)

EP 2 458 065 A1

(12)

EUROPEAN PATENT APPLICATION

(43) Date of publication:
30.05.2012 Bulletin 2012/22

(51) Int Cl.:
D06F 39/14 (2006.01) *D06F 58/22* (2006.01)
D06F 58/20 (2006.01) *E05D 1/04* (2006.01)
E05D 7/10 (2006.01)

(21) Application number: **10192896.8**

(22) Date of filing: **29.11.2010**

(84) Designated Contracting States:
**AL AT BE BG CH CY CZ DE DK EE ES FI FR GB
 GR HR HU IE IS IT LI LT LU LV MC MK MT NL NO
 PL PT RO RS SE SI SK SM TR**
 Designated Extension States:
BA ME

(72) Inventors:
 • **Santarossa, Marco**
33080 Porcia (PN) (IT)
 • **Vian, Alessandro**
33080 Porcia (PN) (IT)

(71) Applicant: **Electrolux Home Products Corporation
 N.V.**
1130 Brussels (BE)

(74) Representative: **Nardoni, Andrea et al**
Electrolux Italia S.p.A.
Corso Lino Zanussi, 30
33080 Porcia (PN) (IT)

(54) **Laundry dryer**

(57) The invention refers to a laundry dryer having an improved operational device inspection port. A laundry dryer according to the invention comprises a casing (1) accommodating therein a drying air circuit and a basement (8) for supporting operational devices for carrying out a drying treatment on laundry, said casing (1) being

provided with a drying air circuit access opening (10) which is closable by a door arrangement (9). Said laundry dryer is characterized in that said door arrangement (9) comprises a panel (14) having a hinge-like edge region (19) that can be removably received in a hinge supporting portion (18) integrally formed on said basement (8).

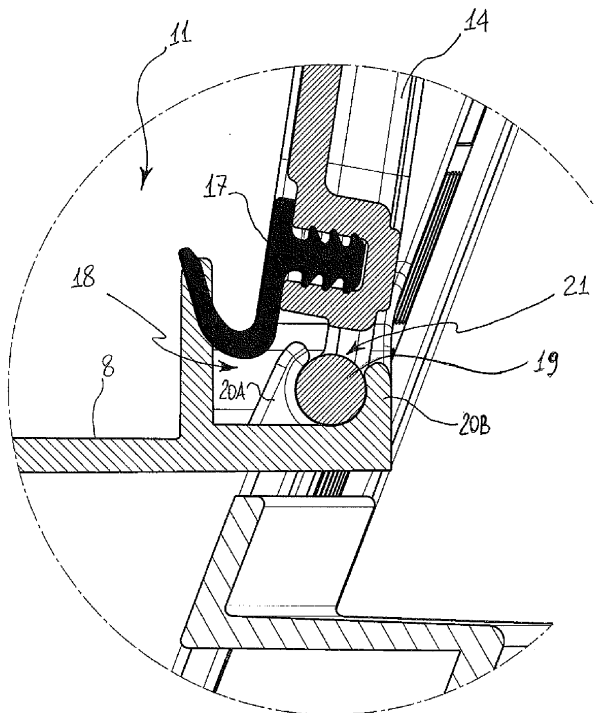

FIG. 6

EP 2 458 065 A1

Description

[0001] The present invention refers to a laundry dryer having an improved operational device inspection port.

[0002] It is known in the art that laundry dryers may be provided with an inspection port placed in the front of the machine casing that allows a user to access drying air circuit in a position corresponding to that of some machine operational devices, like, for example air filtering means and a heat exchanger portion. Thanks to that inspection port, a user may easily perform periodical cleaning of machine components that are more subject to fluff deposition, such as the drying air entrance of a condensing unit, i.e. a heat exchanger adapted to remove moisture from drying air. Such known laundry dryer port is usually closed by an outer hinged door covering a further removable inner panel that is tightly associated to the port so as to avoid drying air leakage. Hinged door has generally an esthetic function because it forms a part of the machine casing other than serving as further protection for accidental opening of the removable inner panel.

[0003] In such known type laundry dryer, when a user has to perform a cleaning operation on some machine operational devices, like a drying air filter and a portion of a moisture condensing unit, she/he has first to move the hinged door from its closed position to an opened position, then removing the inner panel by unlocking one or more locks, and finally accessing the drying air conduit for cleaning said operational devices. In that way a user, who is busy with cleaning operations, has to find a place where temporary leaving the removed inner panel and, above all, at the end of cleaning operations, she/he might forget to remount the inner panel onto the machine thereby possibly causing the laundry dryer not to work appropriately.

[0004] Therefore it would be desirable to avoid the risk that a user, overseeing too many assembling/disassembling operations, may forget to perform necessary actions when access to drying air conduit is needed.

[0005] In addition, further problems may arise in case a user reinstall the inner panel in a wrong manner being only guided by the shape of the opening to be closed through the inner panel.

[0006] A further disadvantage of the known type laundry dryer cited above, consists in that assembling procedure of the inner panel complicates not only the basement design in order to provide appropriate supports for the inner panel, but also the assembling procedure during industrial manufacturing because requires a large number of pieces to be installed.

[0007] The aim of the present invention is therefore to solve the noted drawbacks and thus providing a laundry dryer having an improved arrangement for a door structure giving access to a drying air circuit.

[0008] An object of the present invention is to provide a laundry dryer having a panel for closing a drying air circuit access opening which may be both kept mounted on the machine casing and removed from the latter.

[0009] Another object of the invention is to provide a laundry dryer having a panel covering a drying air circuit access opening wherein said panel can be removed and reinstalled on the machine casing without the use of any tools.

[0010] A further object of the invention is to provide a simplified structure for pivotally mounting a panel covering a drying air circuit access opening.

[0011] Advantages, objects, and features of the invention will be set forth in part in the description and drawings which follow and in part will become apparent to those having ordinary skill in the art upon examination of the following or may be learned from practice of the invention. The objects and advantages of the invention may be reached and attained as particularly pointed out in the appended claims.

[0012] The present invention relates to a laundry dryer comprising a casing accommodating therein a drying air circuit and a basement for supporting operational devices for carrying out a drying treatment on laundry, said casing being provided with a drying air circuit access opening which is closable by a door arrangement, wherein said door arrangement comprises a panel having a hinge-like edge region that can be removably received in a hinge supporting portion integrally formed on said basement.

[0013] Preferably, the hinge supporting portion comprises a plurality of wings arranged in a staggered pattern.

[0014] Preferably, the hinge supporting portion comprises first wings arranged on a first line and spaced apart from one another and second wings arranged on a second line and spaced apart from one another.

[0015] Preferably, second wings face gaps between two adjacent first wings and first wings face gaps between two adjacent second wings.

[0016] Preferably, the first wings are bent towards second wings and/or second wings are bent towards first wings.

[0017] Preferably, the first and second wings form a substantially cylindrical space therebetween for accommodating the hinge-like edge region of said panel.

[0018] Preferably, the hinge-like edge region has a transverse cross sectional rounded shape to removably engage first and second wings.

[0019] Preferably, the panel comprises a plurality of slots adapted to receive a corresponding plurality of second wings, said slots being formed in proximity of the hinge-like edge region.

[0020] Preferably, the first and/or second wings are elastically deformable.

[0021] Preferably, the hinge supporting portion comprises one or more locating projections for aligning the hinge-like edge region relative to the hinge supporting portion.

[0022] Preferably, the panel comprises a locking device.

[0023] Preferably, the panel comprises a removable gasket extending along a panel peripheral region.

[0024] Preferably, said drying air circuit access opening is further closable by a door pivotally associated to said casing.

[0025] Preferably, said door covers the panel.

[0026] Preferably, the door and panel are pivotal about substantially perpendicular axis.

[0027] Preferably, an extractable air filter is arranged in a section of the drying air circuit between the panel and a heat exchanging unit.

[0028] Preferably, the hinge-like edge region extends along a side of the panel.

[0029] Preferably the side of the panel having the hinge-like edge region lies on a horizontal axis when the panel is pivotally coupled to the basement.

[0030] The accompanying drawings, which are included to provide a further understanding of the invention and are incorporated in and constitute a part of this specification, illustrate possible embodiments of the invention and together with the description serve to explain the principles of the invention. Like reference numbers represents like features throughout the accompanying drawings, wherein:

[0031] Figure 1 shows a perspective view of a laundry dryer according to the invention having a door arrangement for allowing access to a drying air circuit;

[0032] Figure 2 shows a perspective detailed view of a drying air circuit access opening of the laundry dryer illustrated in Figure 1 wherein an outer door has been removed and an inner panel is shown in its opened position;

[0033] Figure 3 shows the laundry dryer view of Figure 2 wherein the inner panel has been removed;

[0034] Figure 4 shows a back side of the inner panel of Figure 2;

[0035] Figure 5 shows an enlarged view of detail "A" in Figure 4;

[0036] Figure 6 shows a cross sectional side view of a coupling between the inner panel depicted in Figure 4 and the drying air opening access;

[0037] With reference to Figure 1 a laundry dryer according to the invention comprises a casing 1 formed by a first couple of upright side walls 2A, 2B arranged on a front and rear side of the laundry machine and by a second couple of upright side wall 2C, 2D arranged on lateral sides of such machine. An upper wall portion 3 and a bottom wall portion 4 close the ends of the box-like structure formed by the upright side walls 2A, 2B, 2C, 2D, joined together.

[0038] A laundry container comprising a drum (not shown) rotatably mounted in a tub is provided within the casing 1. Further operational devices, such as a drying air circuit, heat exchanging devices, fluid conduits, fluid pumping devices and so on, for carrying out a drying treatment on laundry are provided within the casing 1. A main front door 5, pivotally coupled to the front upright side wall 2A, is provided for closing a laundry loading opening allowing access to the drum interior region to place laundry to be treated therein.

[0039] An extractable moisture tank in the form of a drawer 6 is slidably arranged on the top of the casing 1, for being periodically emptied by a user in case the laundry dryer cannot be connected to a waste water net through a pipe. A user control interface 7 is arranged on the top of the casing 1 near the drawer 6 for input of laundry drying programs and displaying machine working conditions. On a bottom inner portion of the casing 1 a basement 8 is provided as supporting structure for operational devices of drying machine.

[0040] In a lower portion of casing 1 a door arrangement 9 is provided for closing an opening 10 that gives access to a portion of a drying air circuit 11 (see Figure 2) where air for drying laundry circulates through the drum and a heat exchanging unit 16, such as an air/air heat exchanger or an evaporator of heap pump circuit, adapted to cools and dehumidifies the drying air. Door arrangement 9 comprises an outer door 12 pivotally coupled to casing 1 by a hinge 13 and an inner panel 14 that is removably and pivotally mounted on basement 8. The outer door 12 covers panel 14 when both of them are in a closed position. Hinge 13 of the outer door 12 is arranged on a side of the opening 10 such that door 12 can be opened, for example, with a clockwise rotation about hinge 13 whose axis extends perpendicularly to a surface where the laundry dryer rests.

[0041] Panel 14 comprises a locking device 15, which serves for temporary fixing panel 14 to casing 1. In Figures 1 and 2, locking device 15 is shown in a form of a plate rotatably driven by a wing nut, however it may be embodied in several known forms all allowing a prompt and quick locking/unlocking operation.

[0042] In Figure 2 the outer door 12 has been removed from hinge 13, and panel 14 has been opened by unlocking the locking device 15. As it can be seen, a portion of a drying air circuit 11 becomes accessible to a user thereby allowing she/he to perform periodical cleaning of some operational devices like, for example, an extractable air filter (not shown) to be arranged at the portion of the drying circuit 11 between the panel 14 and the heat exchanging unit 16. Panel 14 is pivotally coupled to basement 8 and rotates about an axis which is preferably substantially orthogonal to the rotational axis of the outer door 12. A gasket 17 is removably associated to panel 14 and extends along the whole peripheral region thereof to tightly close opening 10 thereby avoiding any drying air leakage.

[0043] Figure 3 shows opening 10 without the outer door 12 and the panel 14. Considering also Figures 4-6, it can be seen that basement 8 comprises a hinge supporting portion 18 which is advantageously integrally formed on said basement 8 as a single unitary piece. Hinge supporting portion 18 is arranged to removably receive therein a hinge-like edge region 19 of panel 14.

[0044] The hinge supporting portion 18 comprises a plurality of first wings 20A arranged in a line and preferably in a manner spaced apart from one another. Similarly to the first wings 20A, a further plurality of second wings

20B are arranged in a line parallel and spaced apart from that formed by first wings 20A. Wings 20B are also preferably spaced apart from one another so as to form a staggered pattern with wings 20A. In other words wings 20B, substantially face gaps between two adjacent wings 20A or between a wing 20A and the opening 10 edge.

[0045] Preferably, wings 20A, 20B are bent one towards the other so as to form a substantially cylindrical space 21 therebetween for accommodating the hinge-like edge region 19 of panel 14. In order to allow an easy insertion of the hinge-like edge region 19 inside wings 20A, 20B, and also an easy removal therefrom, said wings 20A, 20B are preferably elastically deformable so as to flex outwardly thereby enlarging the cylindrical space 21 and consequently loosening the hinge supporting region 18. Insertion and/or removal of the hinge-like edge region 19 from the hinge supporting portion 18 may be performed respectively by pushing or pulling panel 14 into or out the cylindrical space 21.

[0046] In order to facilitate alignment between the hinge supporting portion 18 and the hinge-like edge region 19 for correctly positioning panel 14 inside the cylindrical space 21 formed by wings 20A, 20B, one or more locating projections 22 are integrally formed with and projects from basement 8. Such locating projections 22 can be received within corresponding slots 23 provided in proximity of the hinge-like edge region 19, by rotating panel 14 from a substantially closed position in which it obstructs opening 10 to an opened position. Further slots 24, arranged in a line and spaced apart from one another, are formed in proximity of the hinge-like edge region 19 for receiving wings 20B therein. Slots 23, 24 are adapted to receive wings 20B so as to enable the panel to rotate into fully open position wherein the panel lies in a substantially horizontal condition as shown in figure 2. Further, when panel 14 moves towards the open position, engagement of wings 20B into slots 24 prevents any accidental release of the hinge-like edge region 19 from hinge supporting portion 18. On the other hand, when it is desired to remove panel 14 from basement 8 it is sufficient to disengage wings 20B from slots 24 and then pulling panel 14 elastically divaricating wings 20A, 20B.

[0047] Preferably, the hinge-like edge region 19 extends along a side of the panel 14.

[0048] Preferably the side of the panel 14 having the hinge-like edge region 19 lies on a horizontal axis when the panel 14 is pivotally coupled to the basement 8.

[0049] Figure 5 shows an enlarged view of the hinge-like edge region 19 which has a transverse cross sectional rounded shape so as to improve its insertion and removal from wings 20A, 20B.

[0050] Conclusively it can be stated that a laundry dryer according to the invention provides an improved structure for hingedly arranging a covering panel for closing an aperture that allows access to a drying air circuit. Advantageously said structure is partly integrated in the basement body so as to be formed as a single piece therewith. A covering panel as described above may re-

main attached to the laundry dryer casing or, if desired, it may be easily removed from the casing by pulling a hinge region thereof out of supporting wings provided on the machine basement. In this manner, the user can easily remove and clean the covering panel that normally tends to collect fluff and the like.

[0051] Such arrangement for a drying air circuit access door may be applied not only to all laundry dryer types, such as a heat pump type laundry dryer, a air/air condenser type laundry dryer a washing-drying machine and the like but also to any other type of water bearing appliance in which it is needed to access internal operational devices. The inventive laundry dryer may be produced with a less assembling operation and at a cheap cost.

Claims

1. A laundry dryer comprising a casing (1) accommodating therein a drying air circuit and a basement (8) for supporting operational devices for carrying out a drying treatment on laundry, said casing (1) being provided with a drying air circuit access opening (10) which is closable by a door arrangement (9), **characterized in that** said door arrangement (9) comprises a panel (14) having a hinge-like edge region (19) that can be removably received in a hinge supporting portion (18) integrally formed on said basement (8).
2. Laundry dryer according to claim 1 wherein said hinge supporting portion (18) comprises a plurality of wings (20A, 20B) arranged in a staggered pattern.
3. Laundry dryer according to claim 1 or 2 wherein said hinge supporting portion (18) comprises first wings (20A) arranged on a first line and spaced apart from one another and second wings (20B) arranged on a second line and spaced apart from one another.
4. Laundry dryer according to claim 3 wherein second wings (20B) face gaps between two adjacent first wings (20A) and first wings (20B) face gaps between two adjacent second wings (20A).
5. Laundry dryer according to claim 3 or 4 wherein first wings (20A) are bent towards second wings (20B) and/or second wings (20A) are bent towards first wings (20B).
6. Laundry dryer according to any claim 2 to 5 wherein first and second wings (20A, 20B) form a substantially cylindrical space (21) therebetween for accommodating the hinge-like edge region (19) of said panel (14).
7. Laundry dryer according to any claim 2 to 6 wherein the hinge-like edge region (19) has a transverse

cross sectional rounded shape to removably engage first and second wings (20A, 20B).

8. Laundry dryer according to any claim 2 to 7 wherein said panel (14) comprises a plurality of slots (23, 24) adapted to receive a corresponding plurality of second wings (20B), said slots (23, 24) being formed in proximity of the hinge-like edge region (19). 5

9. Laundry dryer according to any claim 2 to 8 wherein said first and/or second wings (20A, 20B) are elastically deformable. 10

10. Laundry dryer according to any preceding claim wherein the hinge supporting portion (18) comprises one or more locating projections (22) for aligning the hinge-like edge region (19) relative to the hinge supporting portion (18). 15

11. Laundry dryer according to any preceding claim wherein panel (14) comprises a locking device (15). 20

12. Laundry dryer according to any preceding claim wherein panel (14) comprises a removable gasket (17) extending along a panel (14) peripheral region. 25

13. Laundry dryer according to any preceding claim wherein said drying air circuit access opening (10) is further closable by a door (12) pivotally associated to said casing (1). 30

14. Laundry dryer according to claim 10 or 11 wherein door (12) and panel (14) are pivotal about substantially perpendicular axis. 35

15. Laundry dryer according to any preceding claim wherein an extractable air filter is arranged in a section of the drying air circuit between the panel (14) and a heat exchanging unit (16). 40

45

50

55

5

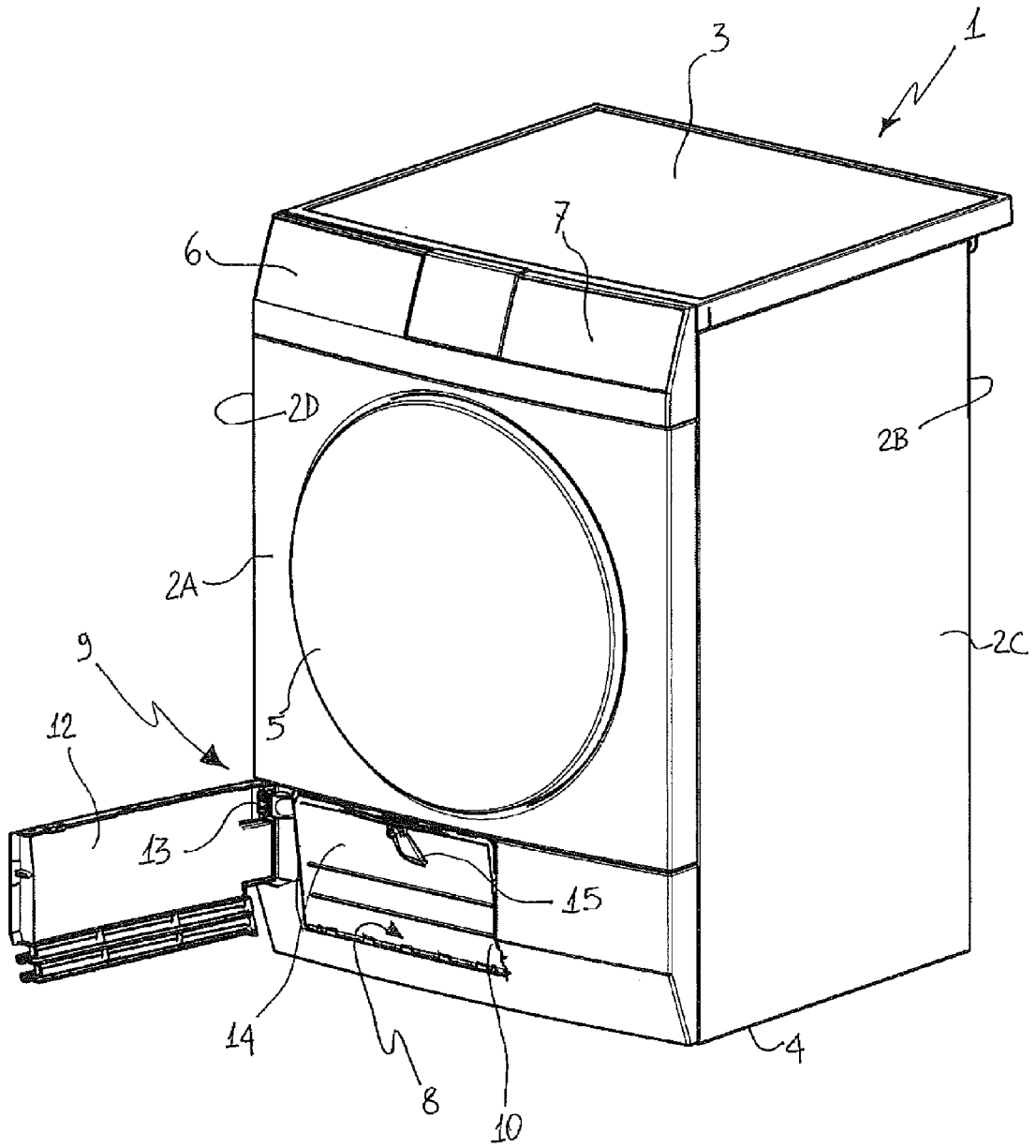

FIG. 1

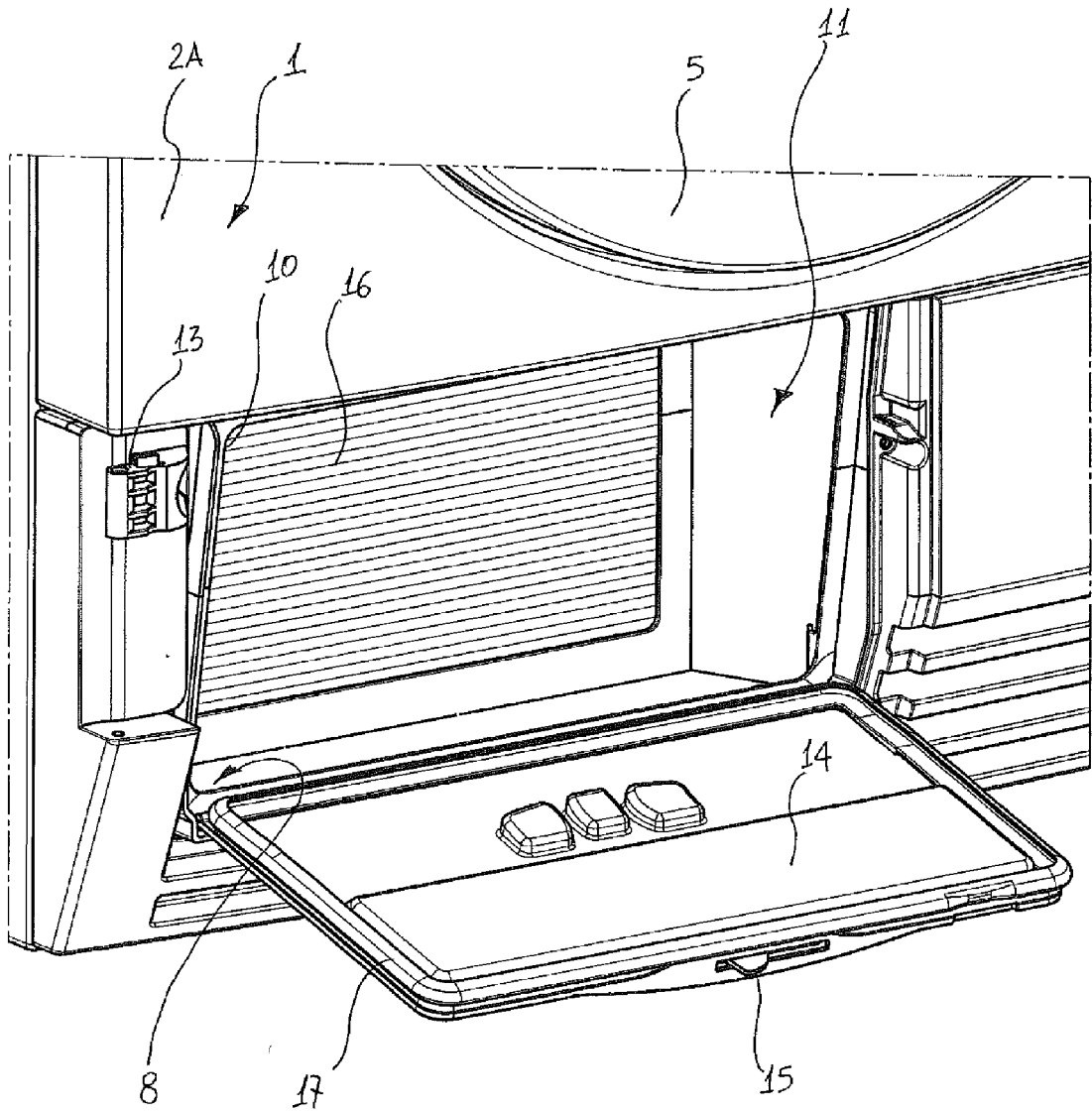

FIG. 2

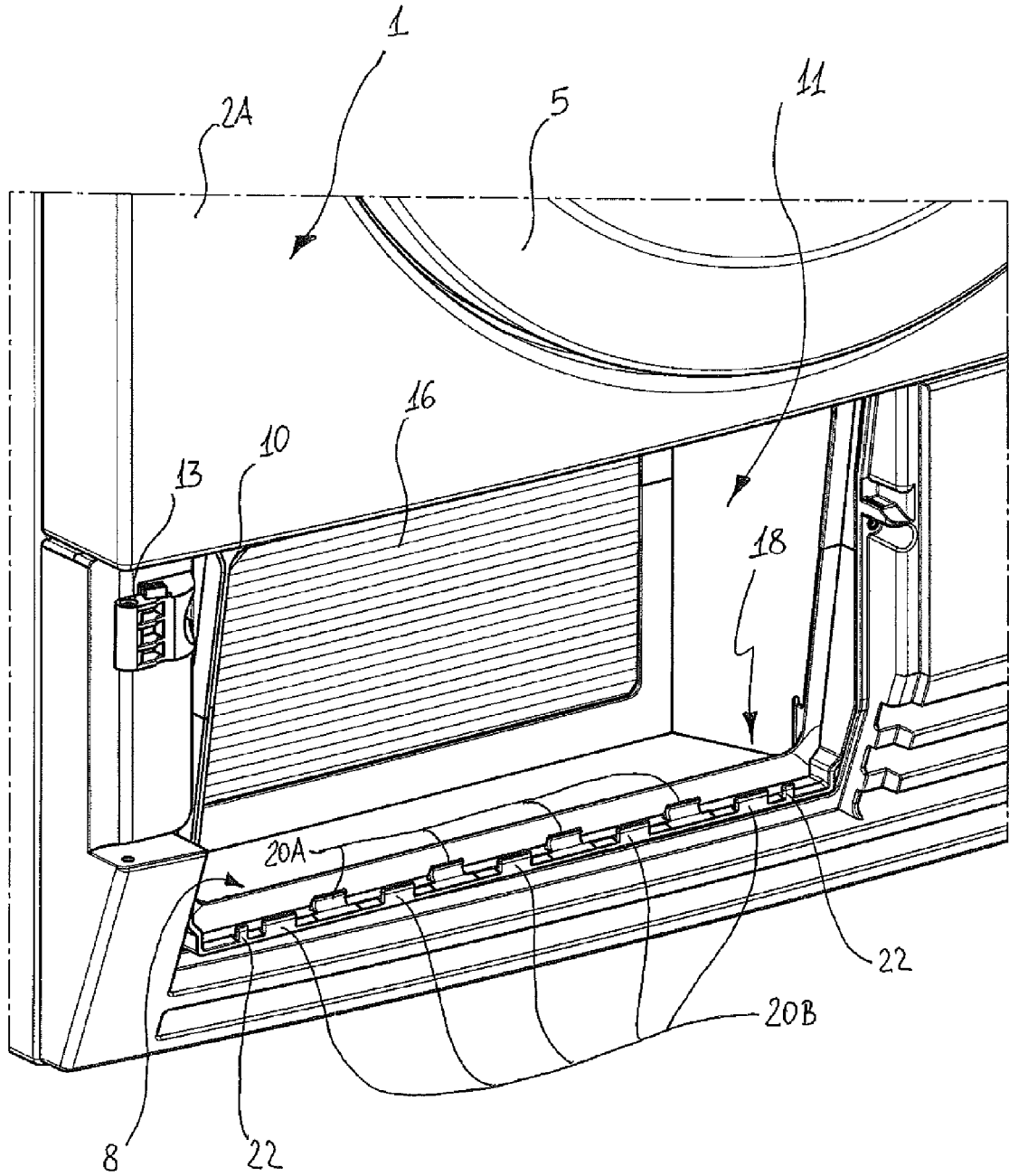
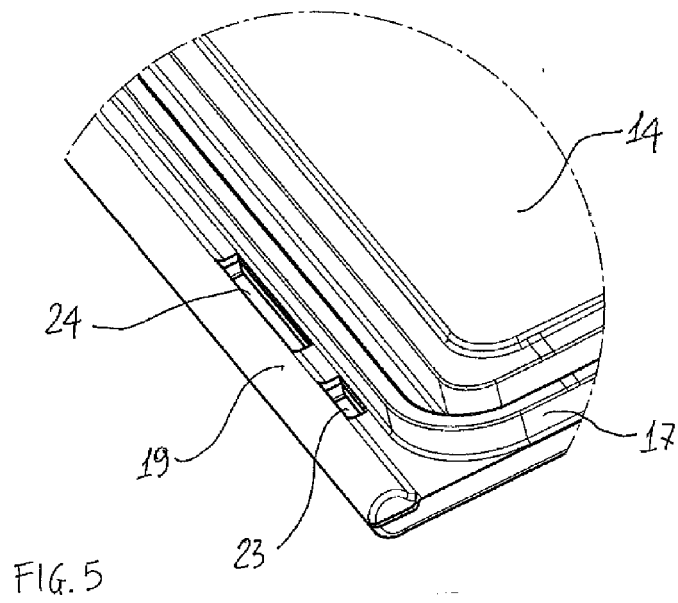
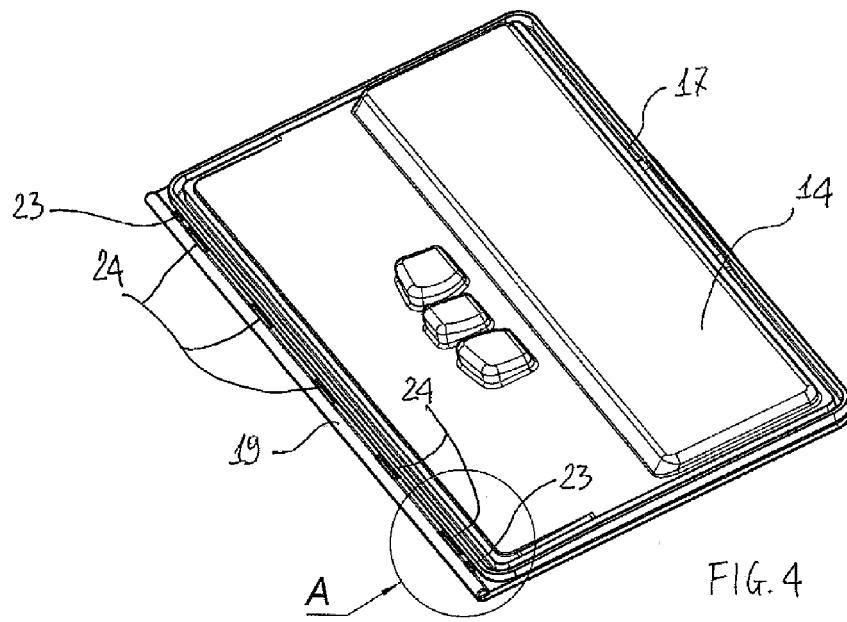

FIG. 3



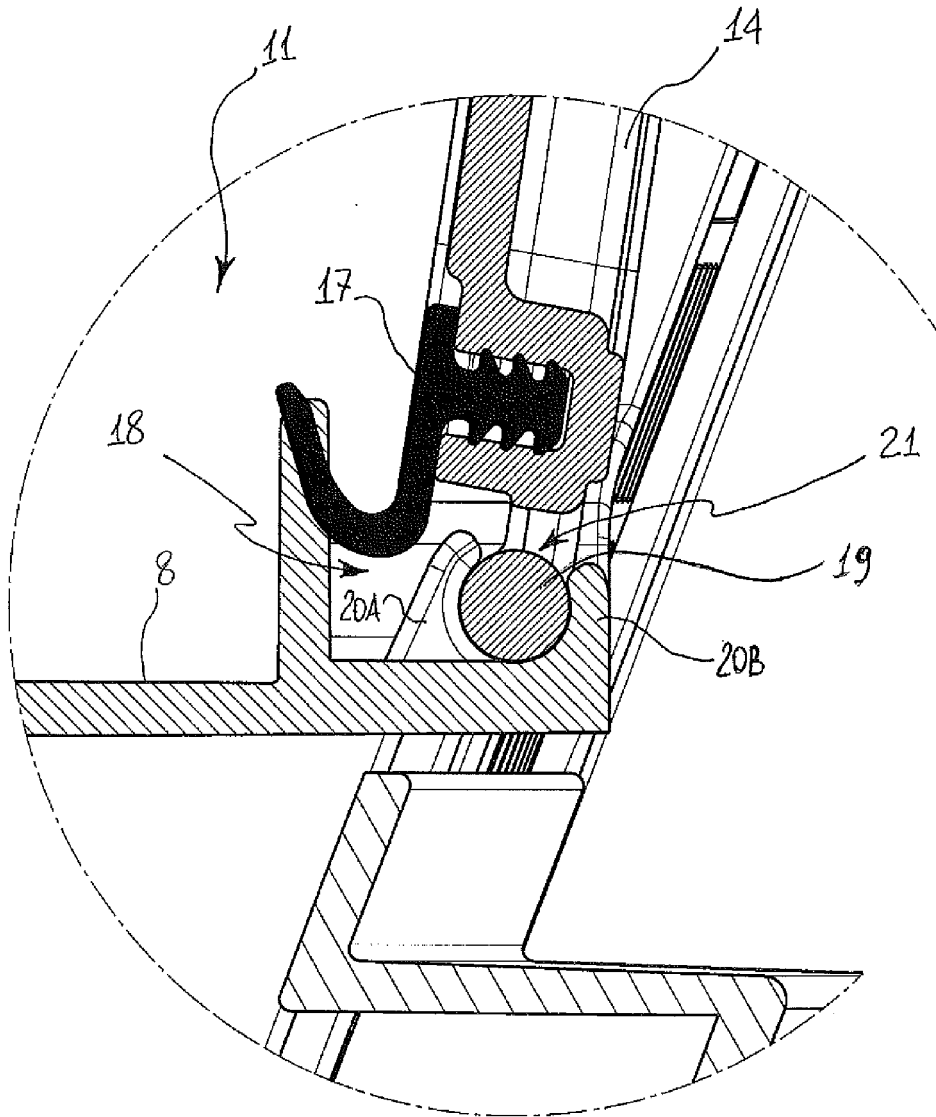

FIG. 6



EUROPEAN SEARCH REPORT

 Application Number
 EP 10 19 2896

DOCUMENTS CONSIDERED TO BE RELEVANT				
Category	Citation of document with indication, where appropriate, of relevant passages	Relevant to claim	CLASSIFICATION OF THE APPLICATION (IPC)	
Y	EP 2 107 155 A2 (MIELE & CIE [DE]) 7 October 2009 (2009-10-07) * figure 2 *	1-15	INV. D06F39/14 D06F58/22 D06F58/20 E05D1/04 E05D7/10	
Y	----- WO 03/095320 A1 (RUBBERMAID INC [US]) 20 November 2003 (2003-11-20) * page 10, line 14 - line 20; figure 2 *	1-15		
Y	----- AU 672 015 B2 (VISCOUNT PLASTICS PTY LTD) 19 September 1996 (1996-09-19) * page 5, line 15 - page 7, line 23; figures 1-6 *	1-3,5-10		
A	----- WO 94/06601 A1 (TRICE DENIS VICTOR PAUL [GB]) 31 March 1994 (1994-03-31) * claims 1-3; figures 2-4 *	1		
A	----- CA 1 227 147 A1 (B & B COSMETICS INC; SCHMIDT GERHARD S E) 22 September 1987 (1987-09-22) * figures 1-4 *	2-10		
A	----- EP 1 524 359 A1 (ELECTROLUX HOME PROD CORP [BE]) 20 April 2005 (2005-04-20) * figure 2 *	1,13		TECHNICAL FIELDS SEARCHED (IPC)
A	----- GB 2 239 674 A (INVICTA PLASTICS LTD [GB]) 10 July 1991 (1991-07-10) * page 2, line 3 - page 4, line 15; figures 1-5 *	1-10		D06F E05D
A	----- DE 41 40 266 C1 (DRÄGERWERK AG) 18 March 1993 (1993-03-18) * column 2, line 59 - column 4, line 48; figures 1,2 *	1-10		
The present search report has been drawn up for all claims				
Place of search		Date of completion of the search	Examiner	
Munich		30 June 2011	Kising, Axel	
CATEGORY OF CITED DOCUMENTS		T : theory or principle underlying the invention E : earlier patent document, but published on, or after the filing date D : document cited in the application L : document cited for other reasons & : member of the same patent family, corresponding document		
X : particularly relevant if taken alone Y : particularly relevant if combined with another document of the same category A : technological background O : non-written disclosure P : intermediate document				

 3
 EPO FORM 1503 03.82 (P04C01)

**ANNEX TO THE EUROPEAN SEARCH REPORT
ON EUROPEAN PATENT APPLICATION NO.**

EP 10 19 2896

This annex lists the patent family members relating to the patent documents cited in the above-mentioned European search report. The members are as contained in the European Patent Office EDP file on
The European Patent Office is in no way liable for these particulars which are merely given for the purpose of information.

30-06-2011

Patent document cited in search report	Publication date	Patent family member(s)	Publication date
EP 2107155 A2	07-10-2009	DE 102008016815 A1	15-10-2009
WO 03095320 A1	20-11-2003	AU 2003228987 A1	11-11-2003
AU 672015 B2	19-09-1996	AU 4484293 A	03-03-1994
WO 9406601 A1	31-03-1994	AU 4979793 A	12-04-1994
CA 1227147 A1	22-09-1987	NONE	
EP 1524359 A1	20-04-2005	AT 331833 T DE 60306526 T2	15-07-2006 16-11-2006
GB 2239674 A	10-07-1991	NONE	
DE 4140266 C1	18-03-1993	EP 0545117 A1 JP 5248135 A US 5311643 A	09-06-1993 24-09-1993 17-05-1994