



US 20110293765A1

(19) **United States**

(12) **Patent Application Publication**
Felker et al.

(10) **Pub. No.: US 2011/0293765 A1**

(43) **Pub. Date: Dec. 1, 2011**

(54) **NONCONFORMING ANTI-SLICE BALL**

Publication Classification

(75) Inventors: **David L. Felker**, Escondido, CA (US); **Douglas C. Winfield**, Madison, AL (US)

(51) **Int. Cl.**
A63B 45/00 (2006.01)

(52) **U.S. Cl.** **425/116**

(73) Assignee: **Aero-X Golf Inc.**, Escondido, CA (US)

(57) **ABSTRACT**

(21) Appl. No.: **13/096,967**

A non-conforming golf ball has a plurality of dimples formed on the outer surface of the ball in a predetermined dimple pattern, the outer surface comprising one or more first areas which include a plurality of first dimples which together have a first dimple volume and at least one second area having a dimple volume less than the first dimple volume, the first and second areas being configured to establish a preferred spin axis. The second area may be a band around the equator which has a lower dimple volume or no dimples, with the polar regions having a higher volume of dimples, creating a preferred spin axis through the poles.

(22) Filed: **Apr. 28, 2011**

Related U.S. Application Data

(60) Provisional application No. 61/328,927, filed on Apr. 28, 2010.

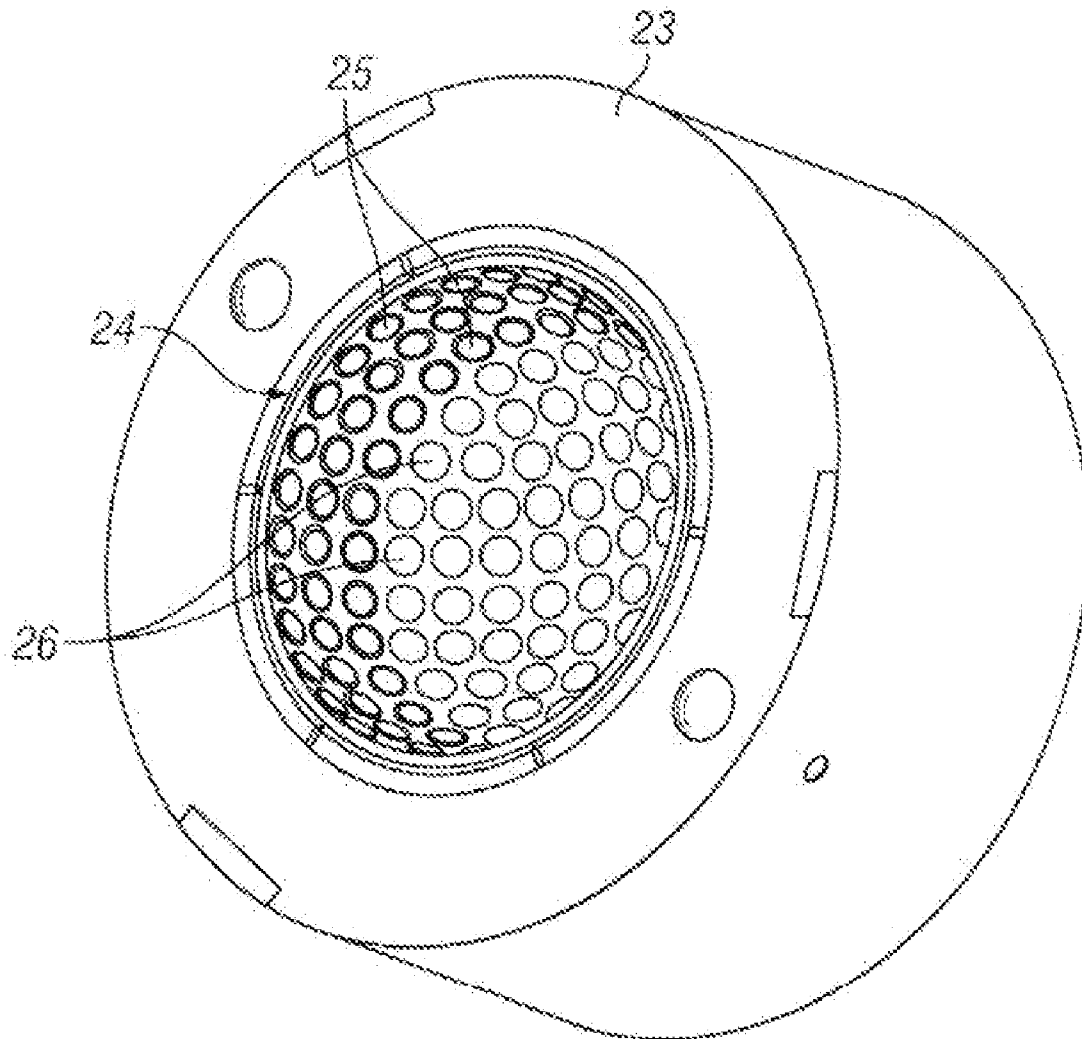

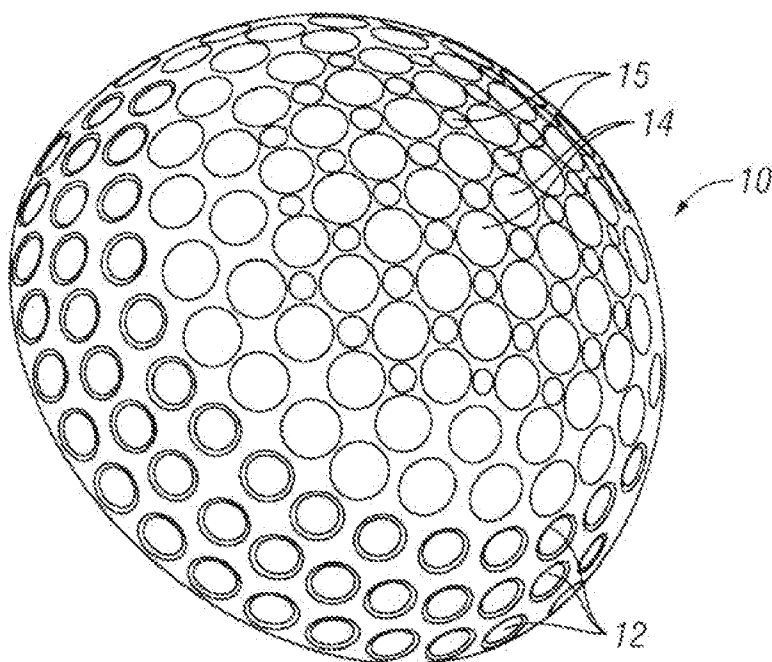

FIG. 1

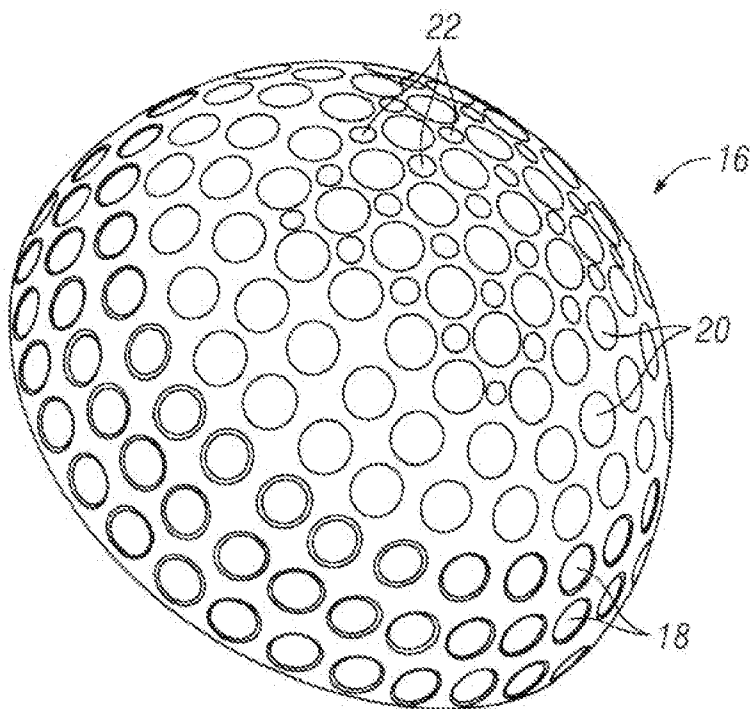

FIG. 2

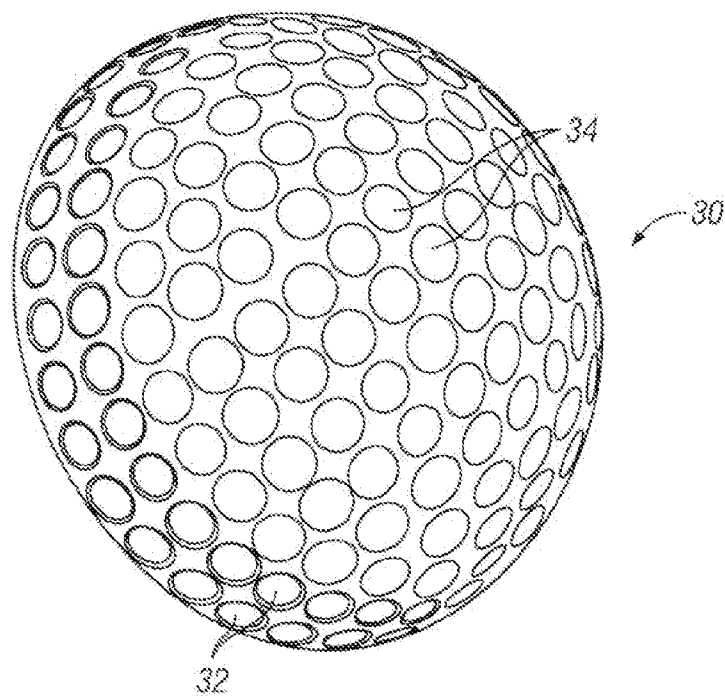
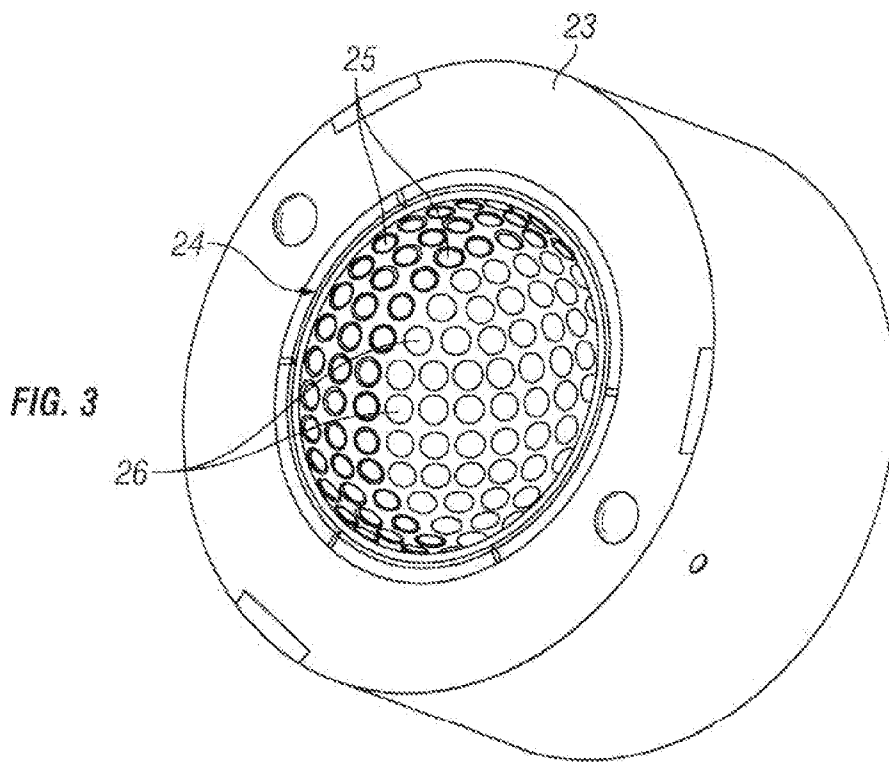

FIG. 4

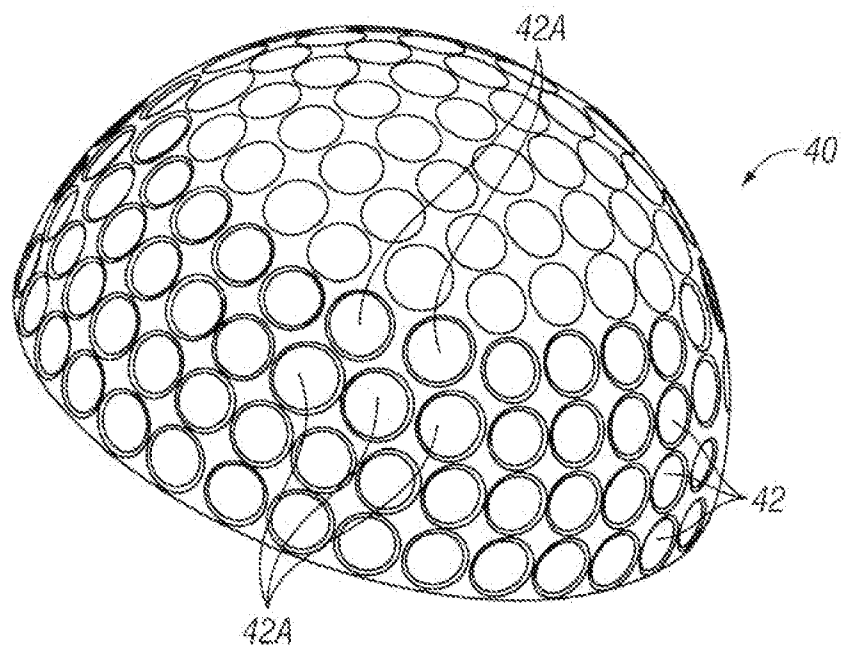

FIG. 5

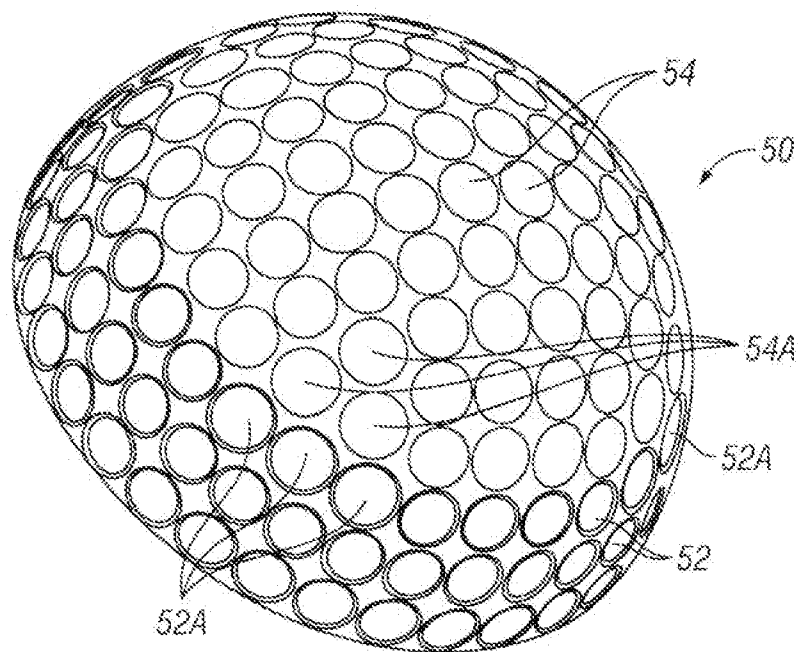

FIG. 6

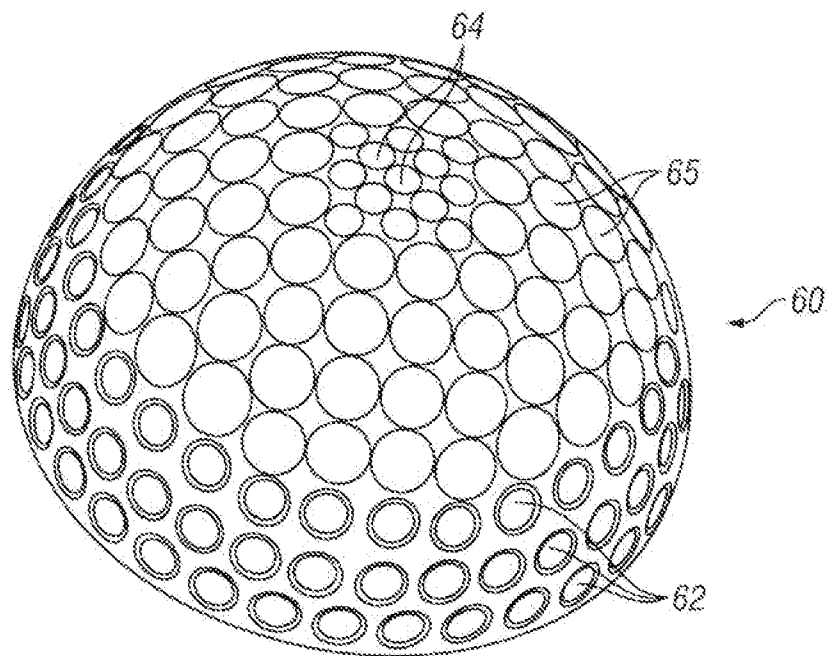

FIG. 7

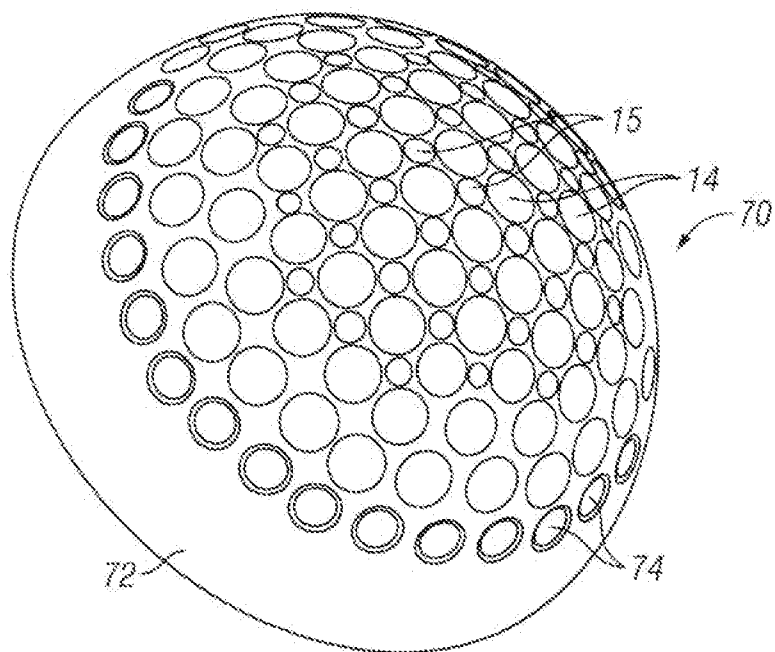
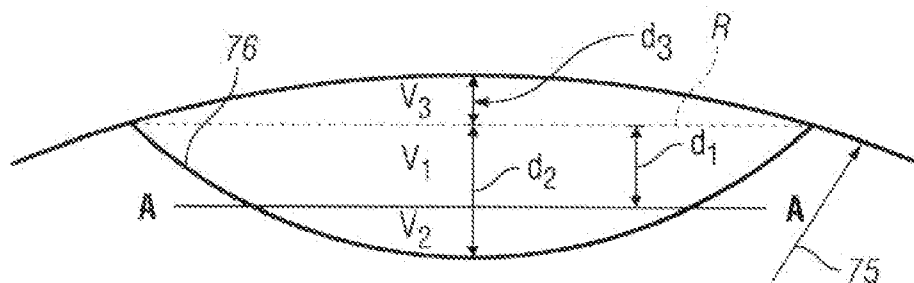

FIG. 8



d_1 = truncated dimple chord depth

d_2 = spherical dimple chord depth

d_3 = depth of cover removed above dimple

V_1 = volume of truncated dimple

$V_1 + V_2$ = volume of spherical dimple

$V_1 + V_2 + V_3$ = volume of cover removed to create spherical dimple

$V_1 + V_3$ = volume of cover removed to create truncated dimple.

FIG. 9

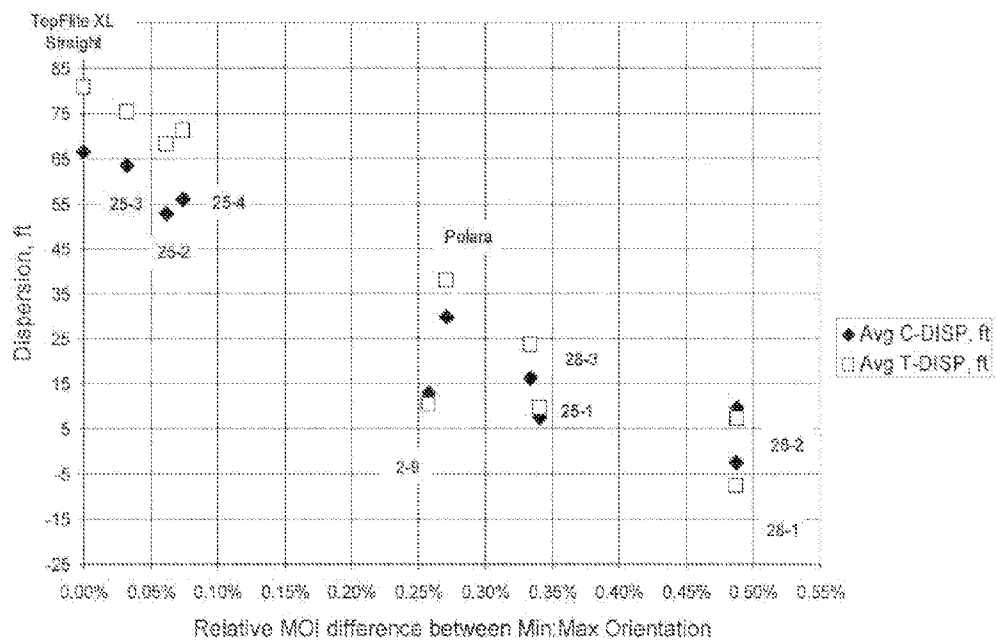

FIG. 10

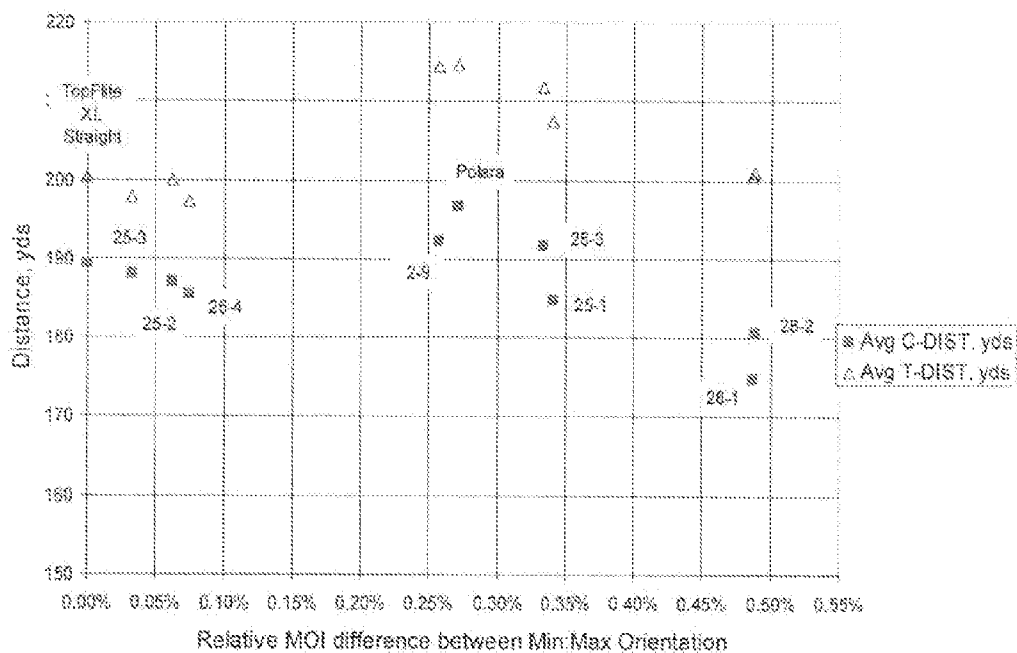

FIG. 11

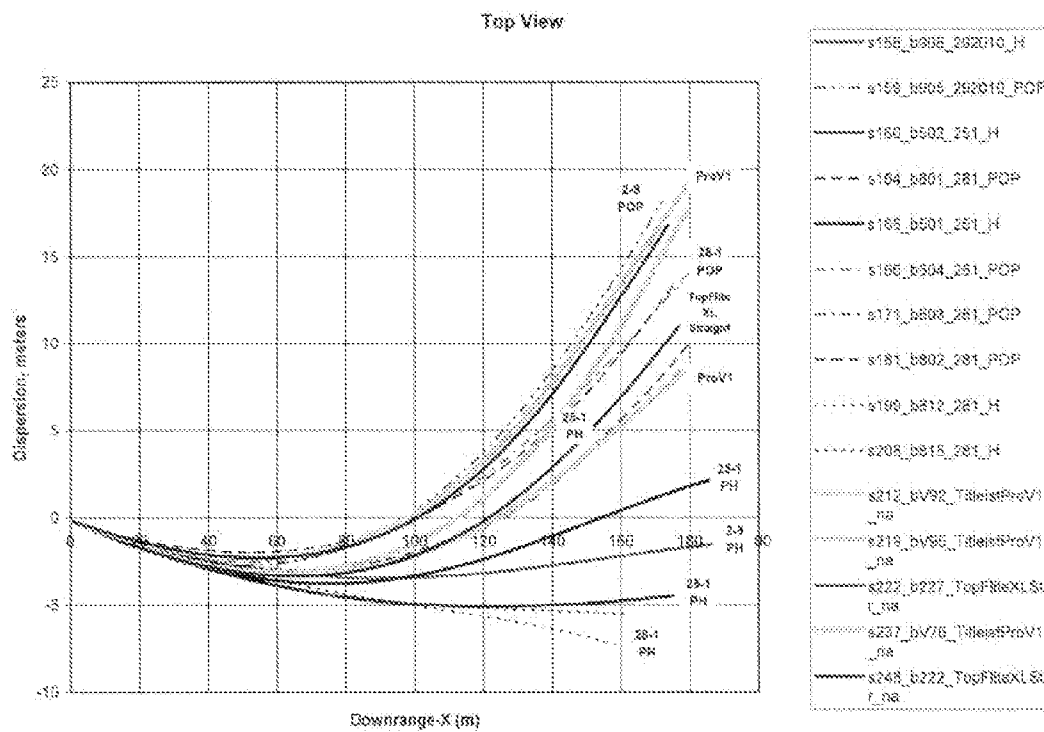

FIG. 12

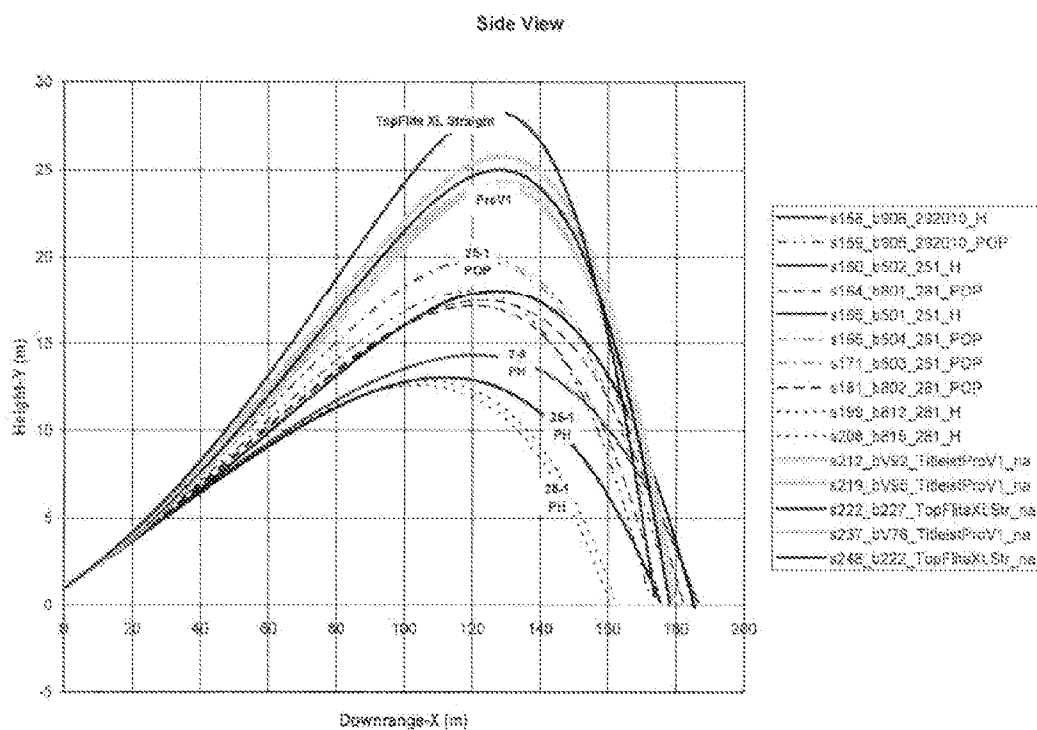

FIG. 13

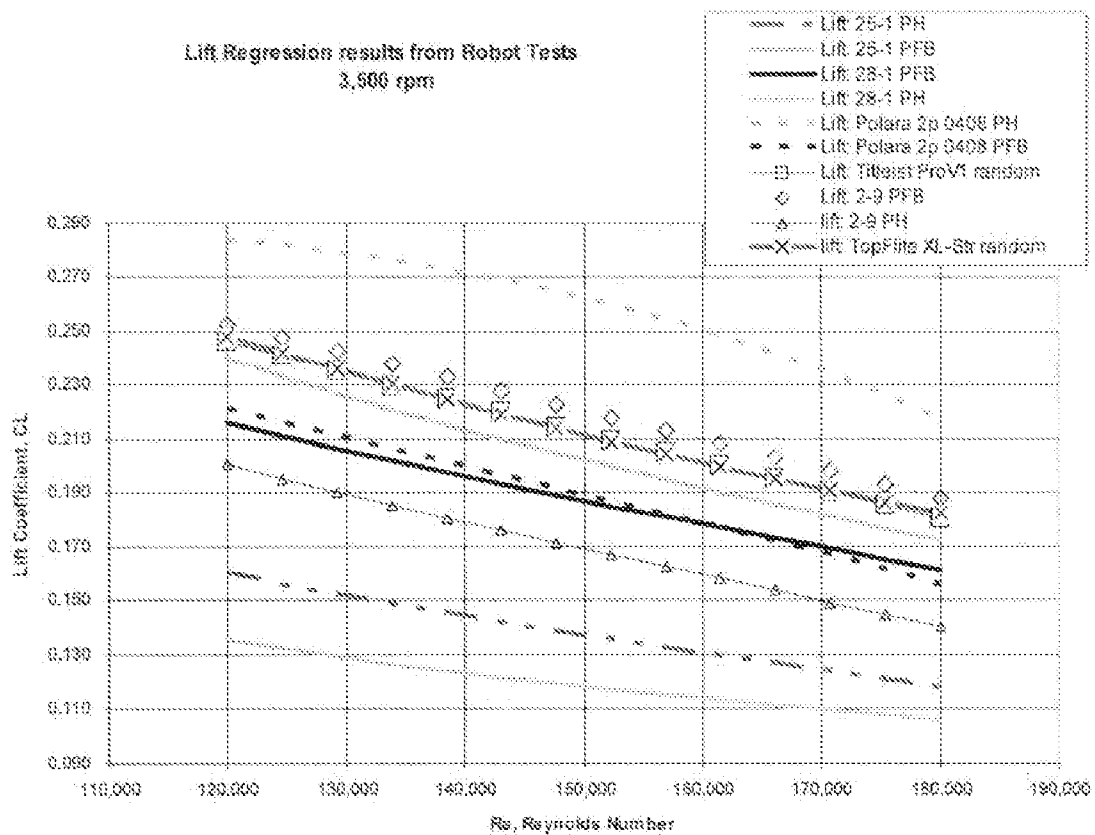

FIG. 14

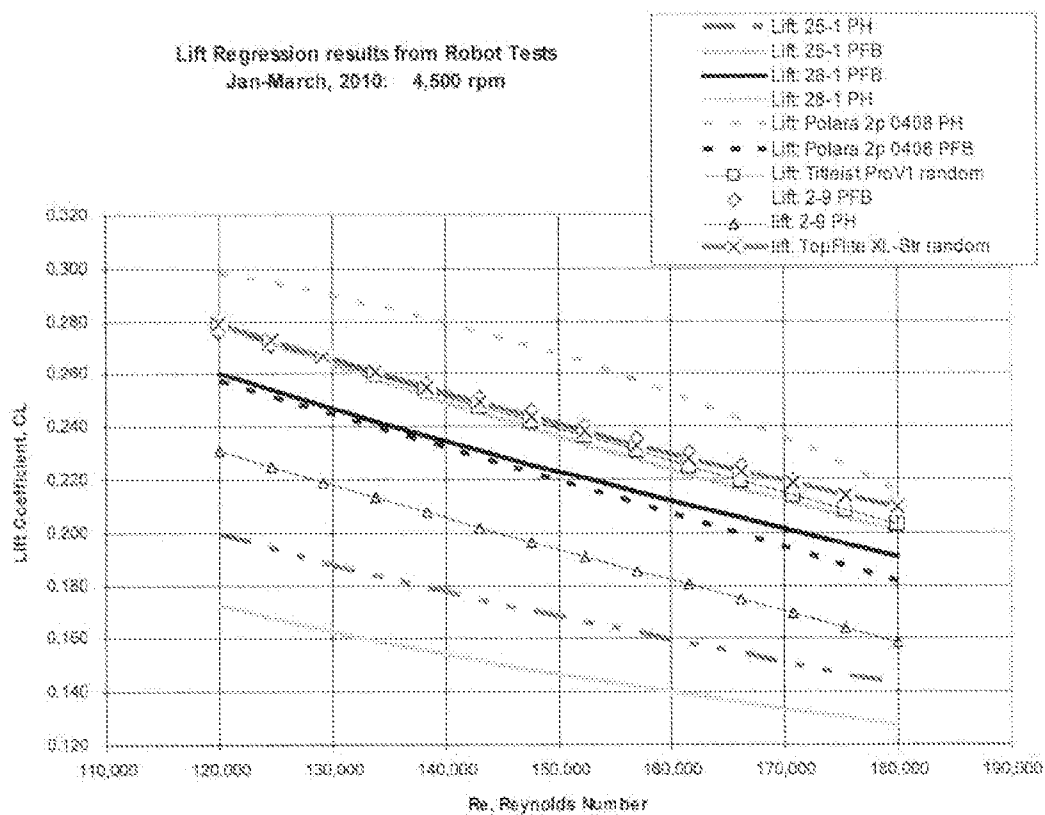

FIG. 15

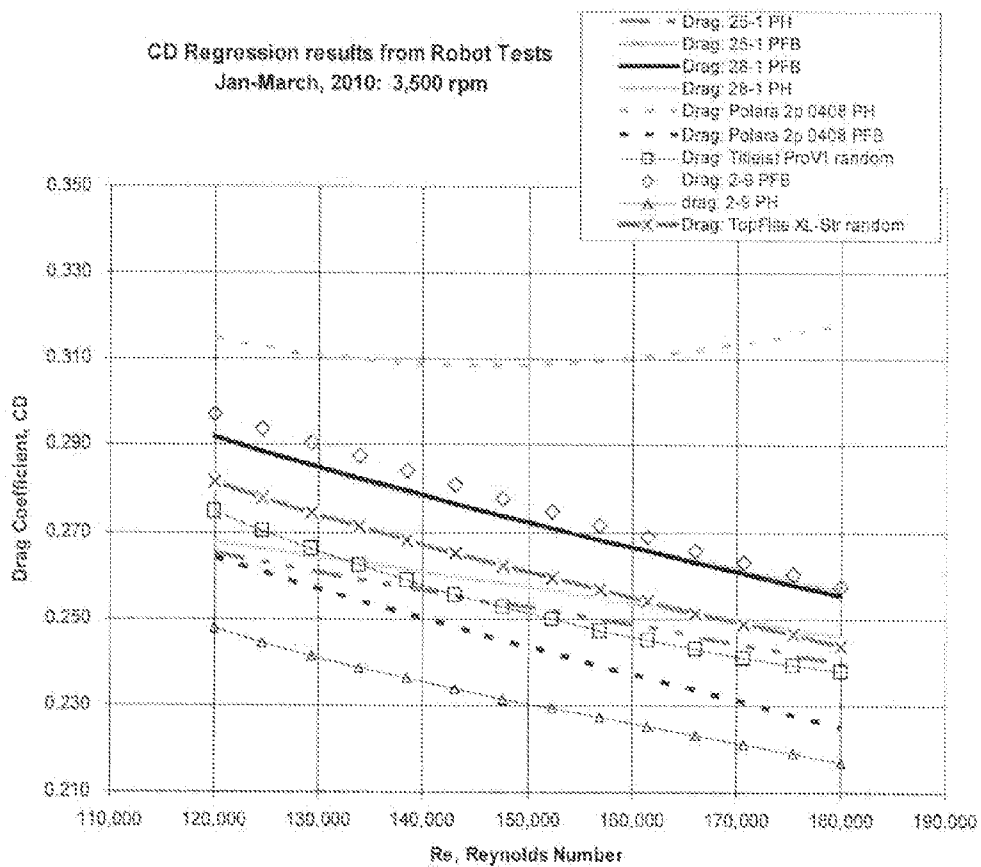

FIG. 16

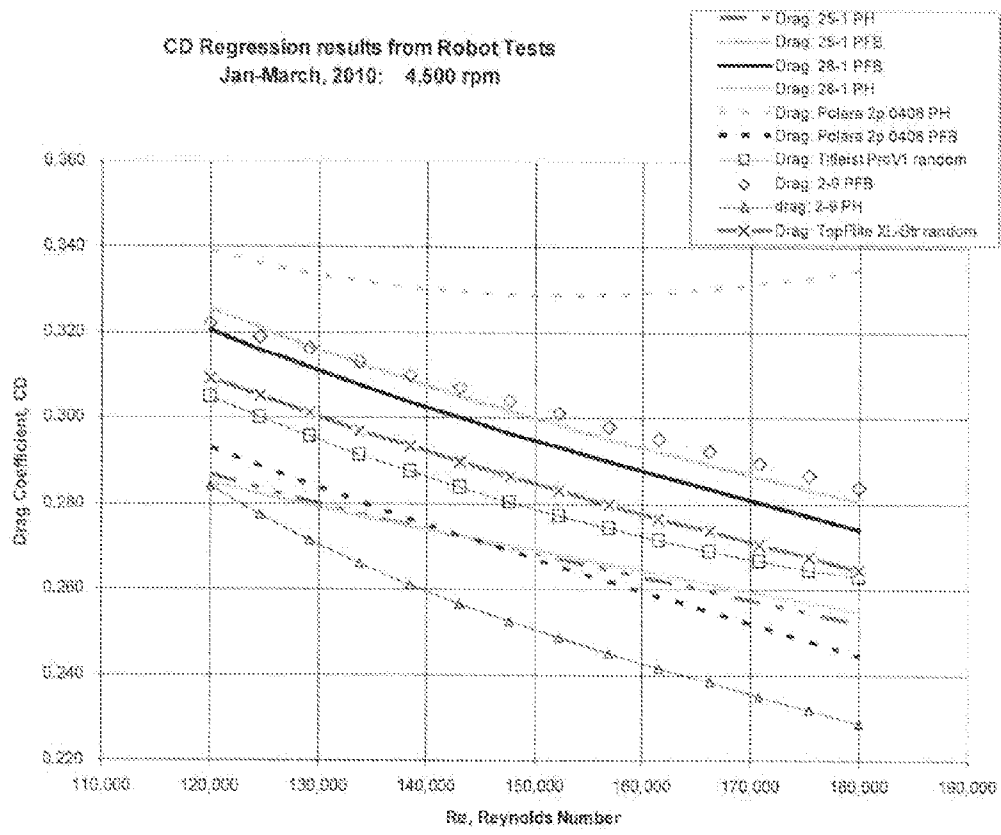

FIG. 17

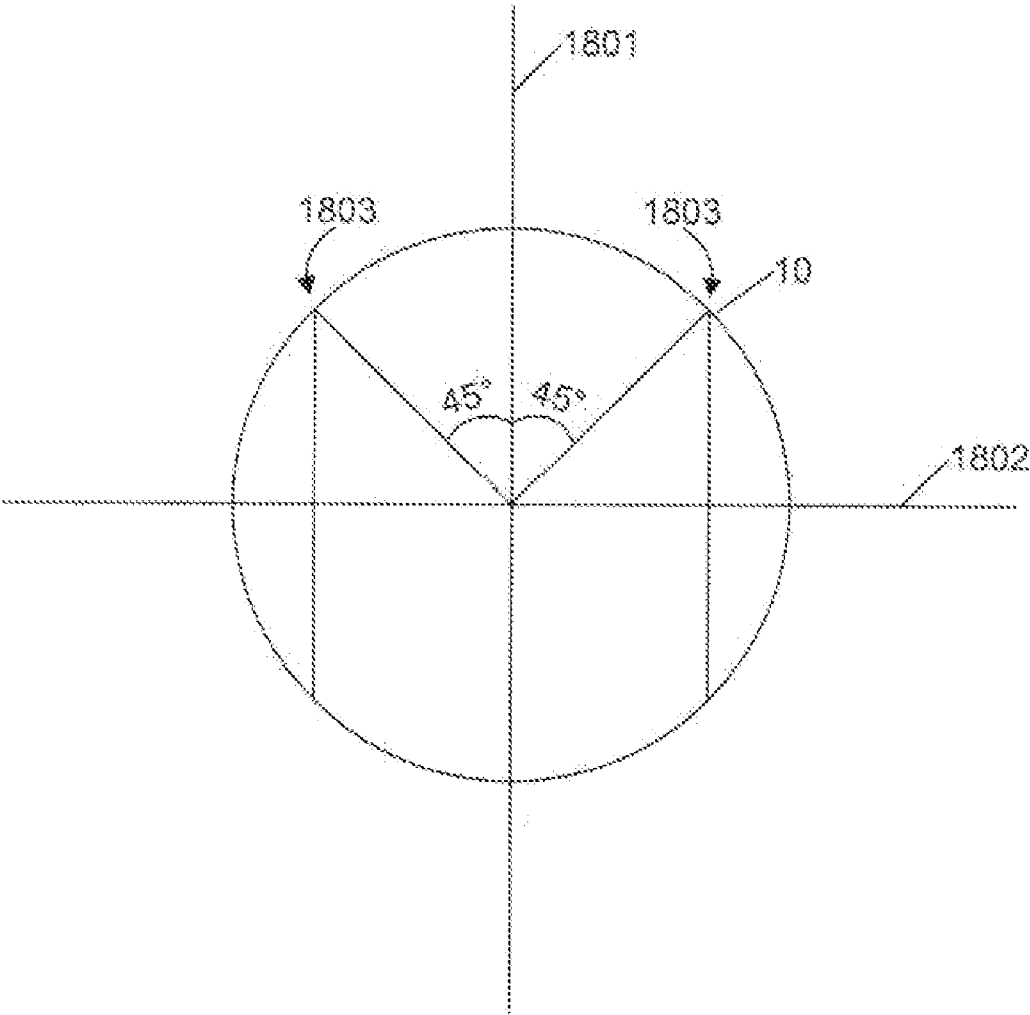

FIG. 18

NONCONFORMING ANTI-SLICE BALL

RELATED APPLICATIONS INFORMATION

[0001] This application claims the benefit under §119(e) of U.S. Provisional Application Ser. No. 61/328,927 filed Apr. 28, 2010 and entitled “Nonconforming Anti-Slice Ball,” which is incorporated herein by reference in its entirety as if set forth in full.

BACKGROUND

[0002] 1. Field of the Invention

[0003] The embodiments described herein relate generally to golf balls and are specifically concerned with golf ball dimple patterns to create desired flight characteristics.

[0004] 2. Related Art

[0005] Golf ball dimple pattern design has long been considered a critical factor in ball flight distance. A golf ball’s velocity, launch angle, and spin rate is determined by the impact between the golf club and the golf ball, but the ball’s trajectory after impact is controlled by gravity and aerodynamics of the ball. Dimples on a golf ball affect both drag and lift, which in turn determine how far the ball flies.

[0006] The aerodynamic forces acting on a golf ball during flight may be determined according to well-understood laws of physics. Scientists have created mathematical models so as to understand these laws and predict the flight of a golf ball. Using these models alone with several readily determined values such as the golf ball’s weight, diameter and lift and drag coefficients, scientists have been able to resolve these aerodynamic forces into the orthogonal components of lift and drag. The lift coefficient relates to the aerodynamic force component acting perpendicular to the path of the golf ball during flight while the drag coefficient relates to the aerodynamic force component acting parallel to the flight path. The lift and drag coefficients vary by golf ball design and are generally a function of the speed and spin rate of the golf ball and for the most part do not depend on the orientation of the golf ball on the tee for a spherically symmetrical or “conforming” golf ball.

[0007] The maximum height a golf ball achieves during flight is directly related to the lift generated by the ball, while the direction that the golf ball takes, specifically how straight a golf ball flies, is related to several factors, some of which include spin and spin axis orientation of the golf ball in relation to the golf ball’s direction of flight. Further, the spin and spin axis are important in specifying the direction and magnitude of the lift force vector. The lift force vector is a major factor in controlling the golf ball flight path in the x, y and z directions. Additionally, the total lift force a golf ball generates during flight depends on several factors, including spin rate, velocity of the ball relative to the surrounding air and the surface characteristics of the golf ball. However, with respect to surface characteristics, not all the regions on the surface of a spinning golf ball contribute equally to the generation of the total lift force. As an example, if the surface of the ball has a spherically symmetrical dimple pattern and the ball is hit so that the spin axis passes through the poles, the surface region closest to the golf ball equator (i.e., the great circle orthogonal to the spin axis) is more important in generating lift than are the regions close to the poles. However, a golf ball that is not hit squarely off the tee will tend to drill off-line and disperse away from its intended trajectory. This is often the case with recreational golfers who impart a slice or a hook spin on the golf ball when striking the ball.

[0008] In order to overcome the drawbacks of a hook or a slice, some golf ball manufacturers have modified the construction of a golf ball in ways that tend to lower the spin rate. Some of these modifications include utilizing hard two-piece

covers and using higher moment of inertia golf balls. Other manufacturers have resorted to modifying the ball surface to decrease the lift characteristics on the ball. These modifications include varying the dimple patterns in order to affect the lift and drag on the of ball.

[0009] Some prior golf balls have been designed with non-conforming or non-symmetrical dimple patterns in an effort to offset the effect of imperfect hits, so that the unskilled golfer can hit a ball more consistently in a straighter path. Although such balls are not legal in professional golf, they are very helpful for the recreational golfer in making the game more fun. One such ball is described in U.S. Pat. No. 3,819, 190 of Nepela et al. This ball is also known as a Polara™ golf ball, and has regions with different numbers of dimples or no dimples. A circumferential band extending around the spherical ball has a plurality of dimples, while polar areas on opposite sides of the band have few or no dimples. For this asymmetric golf ball, the measured lift and drag coefficients are strongly influenced by the orientation of the golf ball on the tee before it is struck. This is evidenced by the fact that the trajectory of the golf ball is strongly influenced by how the golf ball is oriented on the tee. For this ball to work properly, it must be placed on the tee with the poles of the ball oriented such that they are in the plane that is pointed in the intended direction of flight. In this orientation, the ball produces the lowest lift force and thus is less susceptible to hooking and slicing.

[0010] Other golf balls have been constructed of a single or multi-layer core, either solid or wound, that is tightly surrounded by a single or multilayer cover formed from polymeric materials, such as polyurethane, balata rubber, ionomers or a combination. Although some of these golf balls do reduce some hook and slice dispersion, this type of ball construction has the disadvantage of adding cost to the golf ball manufacturing process.

SUMMARY

[0011] Certain embodiments as disclosed herein provide for a golf ball having a dimple pattern which results in reduced hook and slice dispersion.

[0012] In one aspect, a golf ball is designed with a dimple pattern which has reduced or no dimple volume in a selected circumferential band around the ball and more dimple volume in other regions of the ball. This causes the ball to have a “preferred” spin axis because of the weight differences caused by locating different volume dimples in different areas across the ball. This in turn reduces the tendency for dispersion of the ball to the left or right (hooking and slicing) during flight. In one example, the circumferential band of lower dimple volume is around the equator with more dimple volume in the polar regions. This creates a preferred spin axis passing through the poles. In one embodiment, the dimple pattern is also designed to exhibit relatively low lift when the ball spins in the selected orientation around its preferred spin axis. This golf ball is nonconforming or non-symmetrical under United States Golf Association (USGA) rules.

[0013] A golf ball’s preferred or selected spin axis may also be established by placing high and low density materials in specific locations within the core or intermediate layers of the golf ball, but has the disadvantage of adding cost and complexity to the golf ball manufacturing process.

[0014] Where a circumferential band of lower or zero dimple volume is provided about the equator and more dimple volume is provided in the polar regions, a ball is created which has a large enough moment of inertia (MOI) difference between the poles horizontal (PH) orientation and other orientations that the ball has a preferential spin axis going through the poles of the ball. The preferred spin axis

extends through the lowest weight regions of the ball. If these are the polar regions; the preferred axis extends through the poles. If the ball is oriented on the tee so that the “preferred axis” or axis through the poles is pointing up and down (pole over pole or POP orientation), it is less effective in correcting hooks and slices compared to being oriented in the PH orientation when struck.

[0015] In another aspect, the ball may have no dimples in a band about the equator (a land area) and deep dimples in the polar regions. The dimpleless region may be narrow, like a wide seam, or may be wider, i.e. equivalent to removing two or more rows of dimples next to the equator.

[0016] By creating a golf ball with a dimple pattern that has less dimple volume in a band around the equator and by removing more dimple volume from the polar regions adjacent to the low-dimple-volume band, a ball can be created with a large enough moment of inertia (MOI) difference between the poles-horizontal (PH) and other orientations that the ball has a “preferred” spin axis going through the poles of the ball and this preferred spin axis tends to reduce or prevent hooking or slicing when a golfer hits the ball in a manner which would generate other than pure backspin on a normal symmetrically designed golf ball in other words, when this ball is hit in manner which would normally cause hooking or slicing in a symmetrical or conforming ball, the ball tends to rotate about the selected spin axis and thus not hook or slice as much as a symmetrical ball with no selected or “preferred” spin axis. In one embodiment, the dimple pattern is designed so that it generates relatively low lift when rotating in the PH orientation. The resulting golf ball displays enhanced hook and slice correcting characteristics.

[0017] The low volume dimples do not have to be located in a continuous band around the ball’s equator. The low volume dimples could be interspersed with higher volume dimples, the band could be wider in some parts than others, the area in which the low volume dimples are located could have more land area (lack of dimples) than in other areas of the ball. The high volume dimples located in the polar regions could also be inter-dispersed with lower volume dimples; and the polar regions could be wider in some spots than others. The main idea is to create a higher moment of inertia for the ball when it is rotating in one configuration and to do this by manipulating the volume of the dimples across the surface of the ball. This difference in MOI then causes the ball to have a preferred spin axis. The golf ball is then placed on the tee so that the preferred spin axis is oriented approximately horizontally so that when the ball is hit with a hook or slice action, the ball tends to rotate about the horizontal spin axis and thus not hook or slice as much as a symmetrical ball with no preferred spin axis would hook or slice. In some embodiments, the preferred spin axis is the PH orientation.

[0018] Another way to create the preferred spin axis would be to place two or more regions of lower volume or zero volume regions on the ball’s surface and make the regions somewhat co-planar so that they create a preferred spin axis. For example, if two areas of lower volume dimples were placed opposite each other on the ball, then a dumbbell-type weight distribution would exist. In this case, the ball has a preferred spin axis equal to the orientation of the ball when it is rotating end-over-end with the “dumbbell areas”.

[0019] The ball can also be oriented on the tee with the preferred spin axis tilted up to about 45 degrees to the right and then the ball still resists slicing, but does not resist hooking. If the ball is tilted 45 degrees to the left it reduces or prevents hook dispersion, but not slice dispersion. This may be helpful for untrained golfers who tend to hook or slice a ball. When the ball is oriented so that the preferred axis is pointing up and down on the tee (POP orientation for a preferred spin axis in the PH orientation), the ball is much less

effective in correcting hooks and slices compared to being oriented in the PH orientation.

[0020] Other features and advantages will become more readily apparent to those of ordinary skill in the art after reviewing the following detailed description and accompanying drawings.

BRIEF DESCRIPTION OF THE DRAWINGS

[0021] The details of the present embodiments, both as to structure and operation, may be gleaned in part by study of the accompanying drawings, in which like reference numerals refer to like parts, and in which:

[0022] FIG. 1, is a perspective view of one hemisphere of a first embodiment of a golf ball cut in ball through the equator, illustrating a first dimple pattern designed to create a preferred spin axis, the opposite hemisphere having an identical dimple pattern;

[0023] FIG. 2 is a perspective view similar to FIG. 1 illustrating a second embodiment of a golf ball with a second, different dimple pattern;

[0024] FIG. 3 is a perspective view illustrating one hemisphere of a compression molding cavity for making a third embodiment of a golf ball with a third dimple pattern;

[0025] FIG. 4 is a perspective view similar to FIGS. 1 and 2 illustrating a fourth embodiment of a golf ball with a fourth dimple pattern;

[0026] FIG. 5 is a perspective view similar to FIGS. 1, 2 and 4 illustrating a fifth embodiment of a golf ball with a fifth dimple pattern;

[0027] FIG. 6 is a perspective view similar to FIGS. 1, 2, 4 and 5 illustrating a sixth embodiment of a golf ball having a different dimple pattern;

[0028] FIG. 7 is a perspective view similar to FIGS. 1, 2, and 4 to 6 illustrating a seventh embodiment of a golf ball having a different dimple pattern;

[0029] FIG. 8 is perspective view similar to FIG. 1 but illustrating a modified dimple pattern with some rows of dimples around the equator removed;

[0030] FIG. 9 is a diagram illustrating the relationship between the chord depth of a truncated and a spherical dimple in the embodiments of FIGS. 1 to 7;

[0031] FIG. 10 is a graph illustrating the average carry and total dispersion versus the moment of inertia (MOI) difference between the minimum and maximum orientations for balls having each of the dimple patterns of FIGS. 1 to 7, and a modified version of the pattern of FIG. 1, compared with a ball having the dimple pattern of the known non-conforming Polar™ ball and the known TopFlite XL straight ball;

[0032] FIG. 11 is a graph illustrating the average carry and total distance versus MOI difference between the minimum and maximum orientations for the same balls as in FIG. 10;

[0033] FIG. 12 is a graph illustrating the top view of the flights of the golf balls of FIGS. 1, 2 and 3 and several known balls in a robot slice shot test, illustrating the dispersion of ball with distance downrange;

[0034] FIG. 13 is a side view of the flight paths of FIG. 12, illustrating the maximum height of each ball;

[0035] FIGS. 14 to 17 illustrate the lift and drag coefficients versus Reynolds number for the same balls which are the subject of the graphs in FIGS. 12 and 13, at spin rates of 3,500 and 4,500, respectively, for different ball orientations; and

[0036] FIG. 18 is a diagram illustrating a golf ball configured in accordance with another embodiment.

DETAILED DESCRIPTION

[0037] After reading this description it will become apparent to one skilled in the art how to implement the embodiments in various alternative implementations and alternative

applications. Further, although various embodiments will be described herein, it is understood that these embodiments are presented by way of example only, and not limitation. As such, this detailed description of various alternative embodiments should not be construed to limit the scope or breadth of the appended claims.

[0038] FIGS. 1 to 8 illustrate several embodiments of non-conforming or non-symmetrical balls having different dimple patterns, as described in more detail below. In each case, one hemisphere of the ball (or of a mold cavity for making the ball in FIG. 3) cut in half through the equator is illustrated, with the other hemisphere having an identical dimple pattern to the illustrated hemisphere. In each embodiment, the dimples are of greater total volume in a first area or areas, and of less volume in a second area. In the illustrated embodiment, the first areas, which are of greater dimple volume, are in the polar regions of the ball while the second area is a band around the equator, designed to produce a preferred spin axis through the poles of the ball, due to the larger weight around the equatorial band, which has a lower dimple volume, i.e. lower volume of Material removed from the ball surface. Other embodiments may have the reduced volume dimple regions located in different regions of the ball, as long as the dimple pattern is designed to impart a preferred spin axis to the ball, such that hook and slice dispersion is reduced when a ball is struck with the spin axis in a horizontal orientation (PH when the spin axis extends through the poles).

[0039] In the embodiments of FIGS. 1-8, the preferred spin axis goes through the poles of the ball. It will be understood that the design of FIGS. 1-8 can be said to then have a gyroscopic center plane orthogonal to the preferred spin axis, i.e., that goes through and is parallel with the equatorial band. Thus, the designs of FIGS. 1-8 can be said to have a region of lower volume dimples around the gyroscopic center plane. It should also be recognized that in these embodiments, the gyroscopic center plane does not go through all regions, i.e., it does not go through the regions with greater dimple volume.

[0040] It should also be understood that the terms equator or equatorial region and poles can be defined with respect to the gyroscopic center plane. In other words, the equator is in the gyroscopic center plane and the preferred spin axis goes through the poles.

[0041] In fact it has been determined that making dimples more shallow within the region inside the approximately 45 degree point 1803 on the circumference of the ball 10 with respect to the gyroscopic center plane 1801, as illustrated in FIG. 18, further increases the MOI difference between the ball rotating in the PH and pole-over-pole (POP) orientations as described below. Conversely, making dimples deeper inside of the approximately 45 degree point 1803 decreases the MOI difference between the ball rotating in the PH and pole-over-pole (POP) orientations. For reference, the preferred spin axis 1802 is also illustrated in FIG. 18.

[0042] FIG. 1 illustrates one hemisphere of a first embodiment of a non-conforming or non-symmetrical golf ball 10 having a first dimple pattern, hereinafter referred to as dimple pattern design 28-1, or "28-1 ball". The dimple pattern is designed to create a difference in moment of inertia (MOI) between poles horizontal (PH) and other orientations. The dimple pattern of the 28-1 ball has three rows of shallow truncated dimples 12 around the ball's equator, in each hemisphere, so the ball has a total of six rows of shallow truncated dimples. The polar region has a first set of generally larger, deep spherical dimples 14 and a second set of generally smaller, deep spherical dimples 15, which are dispersed between the larger spherical dimples 14. There are no smaller dimples 15 in the two rows of the larger spherical dimples closest to the band of shallow truncated dimples 12. This arrangement removes more weight from the polar areas of the ball and thus further increases the MOI difference between the ball rotating in the PH and pole-over-pole (POP) orientations.

[0043] Shown in Table 1 below are the dimple radius, depth and dimple location information for making a hemispherical injection molding cavity to produce the dimple pattern 28-1 on one hemisphere of the ball, with the other injection molding cavity being identical. As illustrated in Table 1, the ball has a total of 410 dimples (205 in each hemisphere of the ball). The truncated dimples 12 are each of the same radius and truncated chord depth, while the larger and smaller spherical dimples are each of three different sizes (Smaller dimples 1, 2 and 3 and larger dimples 5, 6, 7 in Table 1). Table 1 illustrates the locations of the truncated dimples and each of the different size spherical dimples on one hemisphere of the ball.

TABLE 1

Dimple Pattern Design# = 28-1 Molding cavity internal diameter = 1.692" Total number of dimples on ball = 410											
Dimple # 1			Dimple # 2			Dimple # 3			Dimple # 4		
Type	Radius	SCD	Type	Radius	SCD	Type	Radius	SCD	Type	Radius	SCD
spherical	0.0300	0.0080	spherical	0.0350	0.0080	spherical	0.0400	0.0080	truncated	0.0670	0.0121
TCD	—	—	TCD	—	—	TCD	—	—	TCD	0.0039	—
#	Phi	Theta	#	Phi	Theta	#	Phi	Theta	#	Phi	Theta
1	0	31.89226	1	0	15.8163	1	0	0	1	0	62.0690668
2	90	31.89226	2	17.723349	24.95272	2	45	11.141573	2	0	84.1
3	180	31.89226	3	25.269266	35.26266	3	45	22.380098	3	5.65	73.3833254
4	270	31.89226	4	64.730734	35.26266	4	45	33.669653	4	11.26	84.1
			5	72.276651	24.95272	5	135	11.141573	5	13.34	62.0690668
			6	90	15.8163	6	135	22.380098	6	16.83	73.3833254
			7	107.72335	24.95272	7	135	33.669653	7	22.66	84.1
			8	115.26927	35.26266	8	225	11.141573	8	26.32	62.8658456
			9	154.73073	35.26266	9	225	22.380098	9	27.98	73.3833254
			10	162.27665	24.95272	10	225	33.669653	10	33.82	84.1
			11	180	15.8163	11	315	11.141573	11	38.44	61.760315
			12	197.72335	24.95272	12	315	22.380098	12	39.02	73.3833254
			13	205.26927	35.26266	13	315	33.669653	13	45	84.1

TABLE 1-continued

Dimple Pattern Design# = 28-1					
Molding cavity internal diameter = 1.692"					
Total number of dimples on ball = 410					
14	244.73073	35.26266	14	50.98	73.3833254
15	252.27665	24.95272	15	51.56	61.760315
16	270	15.8163	16	56.18	84.1
17	287.72335	24.95272	17	62.02	73.3833254
18	295.26927	35.26266	18	63.68	62.8658456
19	334.73073	35.26266	19	67.34	84.1
20	342.27665	24.95272	20	73.17	73.3833254
			21	76.66	62.0690668
			22	78.74	84.1
			23	84.35	73.3833254
			24	90	62.0690668
			25	90	84.1
			26	95.65	73.3833254
			27	101.26	84.1
			28	103.34	62.0690668
			29	106.83	73.3833254
			30	112.66	84.1
			31	116.32	62.8658456
			32	117.98	73.3833254
			33	123.82	84.1
			34	128.44	61.760315
			35	129.02	73.3833254
			36	135	84.1
			37	140.98	73.3833254
			38	141.56	61.760315
			39	146.18	84.1
			40	152.02	73.3833254
			41	153.68	62.8658456
			42	157.34	84.1
			43	163.17	73.3833254
			44	166.66	62.0690668
			45	168.74	84.1
			46	174.35	73.3833254
			47	180	62.0690668
			48	180	84.1
			49	185.65	73.3833254
			50	191.26	84.1
			51	193.34	62.0690668
			52	196.83	73.3833254
			53	202.66	84.1
			54	206.32	62.8658456
			55	207.98	73.3833254
			56	213.82	84.1
			57	218.44	61.760315
			58	219.02	73.3833254
			59	225	84.1
			60	230.98	73.3833254
			61	231.56	61.760315
			62	236.18	84.1
			63	242.02	73.3833254
			64	243.68	62.8658456
			65	247.34	84.1
			66	253.17	73.3833254
			67	256.66	62.0690668
			68	258.74	84.1
			69	264.35	73.3833254
			70	270	62.0690668
			71	270	84.1
			72	275.65	73.3833254
			73	281.26	84.1
			74	283.34	62.0690668
			75	286.83	73.3833254
			76	292.66	84.1
			77	296.32	62.8658456
			78	297.98	73.3833254
			79	303.82	84.1
			80	308.44	61.760315
			81	309.02	73.3833254
			82	315	84.1
			83	320.98	73.3833254
			84	321.56	61.760315
			85	326.18	84.1

TABLE 1-continued

Dimple Pattern Design# = 28-1 Molding cavity internal diameter = 1.692" Total number of dimples on ball = 410								
Dimple # 5 Type spherical Radius 0.0670 SCD 0.0121 TCD —			Dimple # 6 Type spherical Radius 0.0725 SCD 0.0121 TCD —			Dimple # 7 Type spherical Radius 0.0750 SCD 0.0121 TCD —		
#	Phi	Theta	#	Phi	Theta	#	Phi	Theta
						86	332.02	73.3833254
						87	333.68	62.8658456
						88	337.34	84.1
						89	343.17	73.3833254
						90	346.66	62.0690668
						91	348.74	84.1
						92	354.35	73.3833254
1	12.73	32.21974	1	0	7.87815	1	8.38	51.07352
2	77.27	32.21974	2	0	23.47509	2	23.8	52.408124
3	102.73	32.21974	3	0	40.93451	3	66.2	52.408124
4	167.27	32.21974	4	19.68	42.05	4	81.62	51.07352
5	192.73	32.21974	5	25.81	17.61877	5	98.38	51.07352
6	257.27	32.21974	6	32.87	28.60436	6	113.8	52.408124
7	282.73	32.21974	7	35.9	39.62978	7	156.2	52.408124
8	347.27	32.21974	8	37.5	50.62533	8	171.62	51.07352
			9	52.5	50.62533	9	188.38	51.07352
			10	54.1	39.62978	10	203.8	52.408124
			11	57.13	28.60436	11	246.2	52.408124
			12	64.19	17.61877	12	261.62	51.07352
			13	70.32	42.05	13	278.38	51.07352
			14	90	7.87815	14	293.8	52.408124
			15	90	23.47509	15	336.2	52.408124
			16	90	40.93451	16	351.62	51.07352
			17	109.68	42.05			
			18	115.81	17.61877			
			19	122.87	28.60436			
			20	125.9	39.62978			
			21	127.5	50.62533			
			22	142.5	50.62533			
			23	144.1	39.62978			
			24	147.13	28.60436			
			25	154.19	17.61877			
			26	160.32	42.05			
			27	180	7.87815			
			28	180	23.47509			
			29	180	40.93451			
			30	199.68	42.05			
			31	205.81	17.61877			
			32	212.87	28.60436			
			33	215.9	39.62978			
			34	217.5	50.62533			
			35	232.5	50.62533			
			36	234.1	39.62978			
			37	237.13	28.60436			
			38	244.19	17.61877			
			39	250.32	42.05			
			40	270	7.87815			
			41	270	23.47509			
			42	270	40.93451			
			43	289.68	42.05			
			44	295.81	17.61877			
			45	302.87	28.60436			
			46	305.9	39.62978			
			47	307.5	50.62533			
			48	322.5	50.62533			
			49	324.1	39.62978			
			50	327.13	28.60436			
			51	334.19	17.61877			
			52	340.32	42.05			

[0044] As seen in FIG. 1 and Table 1, the first, larger set of spherical dimples 14 include dimples of three different radii, specifically 8 dimples of a first, smaller radius (0.067 inches), 52 dimples of a second, larger radius (0.0725 inches) and 16 dimples of a third, largest radius (0.075 inches). Thus, there are a total of 76 larger spherical dimples 14 in each hemisphere of ball 10. The second, smaller set of spherical dimples, which are arranged between the larger dimples in a region closer to the pole are also in three slightly different sizes from approximately 0.03 inches to approximately 0.04 inches, and one hemisphere of the ball includes 37 smaller spherical dimples. The truncated dimples are all of the same size and have a radius of 0.067 inches (the same as the smallest spherical dimples of the first set) and a truncated chord depth of 0.0039 inches. There are 92 truncated dimples in one hemisphere of the ball. All of the spherical dimples 14 have the same spherical chord depth of 0.0121 inches, while the smaller spherical dimples 15 have a spherical chord depth of 0.008 inches. Thus, the truncated chord depth of the truncated dimples is significantly less than the spherical chord depth of the spherical dimples, and is about one third of the depth of the larger spherical dimples 14, and about one half the depth of the smaller dimples 15.

[0045] With this dimple arrangement, significantly more material is removed from the polar regions of the ball to create the larger, deeper spherical dimples, and less material is removed to create the band of shallower, truncated dimples around the equator. In testing described in more detail below, the 28-1 dimple pattern of FIG. 1 and Table 1 was found to have a preferred spin axis through the poles, as expected, so that dispersion is reduced if the ball is placed on the tee in a

poles horizontal (PH) orientation. This ball was also found to generate relatively low lift when the ball spins about the preferred spin axis.

[0046] FIG. 2 illustrates one hemisphere of a second embodiment of a ball 16 having a different dimple pattern, hereinafter referred to as 25-1, which has three rows of shallow truncated dimples 18 around the ball's equator in each hemisphere and deep spherical dimples 20 in the polar region of the ball. The deep dimples closest to the pole also have smaller dimples 22 dispersed between the larger dimples. The overall dimple pattern in FIG. 2 is similar to that of FIG. 1, but the total number of dimples is less (386). Ball 16 has the same number of truncated dimples as ball 10, but has fewer spherical dimples of less volume than the spherical dimples of ball 10 (see Table 2 below). Each hemisphere of ball 16 has 92 truncated dimples and 101 spherical dimples 20 and 22. The main difference between patterns 28-1 and 25-1 is that the 28-1 ball of FIG. 1 has more weight removed from the polar regions because the small dimples between deep dimples are larger in number and volume for dimple pattern 28-1 compared to 25-1, and the larger, deeper dimples are also of generally larger size for dimple pattern 28-1 than the larger spherical dimples in the 25-1 dimple pattern. The larger spherical dimples 20 in the ball 16 are all of the same size, which is equal to the smallest large dimple size in the 28-1 ball. The truncated dimples in FIG. 2 are of the same size as the truncated dimples in FIG. 1, and the truncated dimple radius is the same as the radius of the larger spherical dimples 20.

[0047] Shown in Table 2 are the dimple radius, depth and dimple location information for making an injection molding cavity to produce the dimple pattern 25-1 of FIG. 2.

TABLE 2

Dimple Pattern Design# = 25-1 Molding cavity internal diameter = 1.694" Total number of dimples on ball = 386											
Dimple # 1			Dimple # 2			Dimple # 3			Dimple # 4		
Type spherical			Type spherical			Type truncated			Type spherical		
Radius 0.0300			Radius 0.0350			Radius 0.0670			Radius 0.0670		
SCD 0.0080			SCD 0.0080			SCD 0.0121			SCD 0.0121		
TCD —			TCD —			TCD 0.0039			TCD —		
#	Phi	Theta	#	Phi	Theta	#	Phi	Theta	#	Phi	Theta
1	0	32.02119	1	0	0	1	0	62.32	1	0	7.91
2	90	32.02119	2	0	15.88024	2	0	84.44	2	0	23.57
3	180	32.02119	3	17.72335	25.0536	3	5.65	73.68	3	0	41.1
4	270	32.02119	4	45	11.18662	4	11.26	84.44	4	8.38	51.28
			5	45	22.47058	5	13.34	62.32	5	12.73	32.35
			6	72.27665	25.0536	6	16.83	73.68	6	19.68	42.22
			7	90	15.88024	7	22.66	84.44	7	23.8	52.62
			8	107.7233	25.0536	8	26.32	63.12	8	25.81	17.69
			9	135	11.18662	9	27.98	73.68	9	32.87	28.72
			10	135	22.47058	10	33.82	84.44	10	35.9	39.79
			11	162.2767	25.0536	11	38.44	62.01	11	37.5	50.83
			12	180	15.88024	12	39.02	73.68	12	52.5	50.83
			13	197.7233	25.0536	13	45	84.44	13	54.1	39.79
			14	225	11.18662	14	50.98	73.68	14	57.13	28.72
			15	225	22.47058	15	51.56	62.01	15	64.19	17.69
			16	252.2767	25.0536	16	56.18	84.44	16	66.2	52.62
			17	270	15.88024	17	62.02	73.68	17	70.32	42.22
			18	287.7233	25.0536	18	63.68	63.12	18	77.27	32.35
			19	315	11.18662	19	67.58	84.44	19	81.62	51.28
			20	315	22.47058	20	73.17	73.68	20	90	7.91
			21	342.2767	25.0536	21	76.66	62.32	21	90	23.57
						22	78.84	84.44	22	90	41.1
						23	84.35	73.68	23	98.38	51.28
						24	90	62.32	24	102.73	32.35
						25	90	84.44	25	109.68	42.22
						26	95.65	73.68	26	113.8	52.62

TABLE 2-continued

Dimple Pattern Design# = 25-1 Molding cavity internal diameter = 1.694" Total number of dimples on ball = 386											
Dimple # 1 Type spherical Radius 0.0300 SCD 0.0080 TCD —			Dimple # 2 Type spherical Radius 0.0350 SCD 0.0080 TCD —			Dimple # 3 Type truncated Radius 0.0670 SCD 0.0121 TCD 0.0039			Dimple # 4 Type spherical Radius 0.0670 SCD 0.0121 TCD —		
#	Phi	Theta	#	Phi	Theta	#	Phi	Theta	#	Phi	Theta
						27	101.26	84.44	27	115.81	17.69
						28	103.34	62.32	28	122.87	28.72
						29	106.83	73.68	29	125.9	39.79
						30	112.66	84.44	30	127.5	50.83
						31	116.32	63.12	31	142.5	50.83
						32	117.98	73.68	32	144.1	39.79
						33	123.82	84.44	33	147.13	28.72
						34	128.44	62.01	34	154.19	17.69
						35	129.02	73.68	35	156.2	52.62
						36	135	84.44	36	160.32	42.22
						37	140.98	73.68	37	167.27	32.35
						38	141.56	62.01	38	171.62	51.28
						39	146.18	84.44	39	180	7.91
						40	152.02	73.68	40	180	23.57
						41	153.68	63.12	41	180	41.1
						42	157.58	84.44	42	188.38	51.28
						43	163.17	73.68	43	192.73	32.35
						44	166.66	62.32	44	199.68	42.22
						45	168.84	84.44	45	203.8	52.62
						46	174.35	73.68	46	205.81	17.69
						47	180	84.44	47	212.87	28.72
						48	180	62.32	48	215.9	39.79
						49	185.65	73.68	49	217.5	50.83
						50	191.26	84.44	50	232.5	50.83
						51	193.34	62.32	51	234.1	39.79
						52	196.83	73.68	52	237.13	28.72
						53	202.66	84.44	53	244.19	17.69
						54	206.32	63.12	54	246.2	52.62
						55	207.98	73.68	55	250.32	42.22
						56	213.82	84.44	56	257.27	32.35
						57	218.44	62.01	57	261.62	51.28
						58	219.02	73.68	58	270	7.91
						59	225	84.44	59	270	23.57
						60	230.98	73.68	60	270	41.1
						61	231.56	62.01	61	278.38	51.28
						62	236.18	84.44	62	282.73	32.35
						63	242.02	73.68	63	289.68	42.22
						64	243.68	63.12	64	293.8	52.62
						65	247.58	84.44	65	295.81	17.69
						66	253.17	73.68	66	302.87	28.72
						67	256.66	62.32	67	305.9	39.79
						68	258.84	84.44	68	307.5	50.83
						69	264.35	73.68	69	322.5	50.83
						70	270	62.32	70	324.1	39.79
						71	270	84.44	71	327.13	28.72
						72	275.65	73.68	72	334.19	17.69
						73	281.26	84.44	73	336.2	52.62
						74	283.34	62.32	74	340.32	42.22
						75	286.83	73.68	75	347.27	32.35
						76	292.66	84.44	76	351.62	51.28
						77	296.32	63.12			
						78	297.98	73.68			
						79	303.82	84.44			
						80	308.44	62.01			
						81	309.02	73.68			
						82	315	84.44			
						83	320.98	73.68			
						84	321.56	62.01			
						85	326.18	84.44			
						86	332.02	73.68			
						87	333.68	63.12			
						88	337.58	84.44			
						89	343.17	73.68			
						90	346.66	62.32			

TABLE 2-continued

Dimple Pattern Design# = 25-1 Molding cavity internal diameter = 1.694" Total number of dimples on ball = 386											
Dimple # 1			Dimple # 2			Dimple # 3			Dimple # 4		
Type spherical			Type spherical			Type truncated			Type spherical		
Radius 0.0300			Radius 0.0350			Radius 0.0670			Radius 0.0670		
SCD 0.0080			SCD 0.0080			SCD 0.0121			SCD 0.0121		
TCD —			TCD —			TCD 0.0039			TCD —		
#	Phi	Theta	#	Phi	Theta	#	Phi	Theta	#	Phi	Theta
						91	348.84	84.44			
						92	354.35	73.68			

[0048] As indicated in Table 2, ball 25-1 has only two different size smaller spherical dimples 22 in the polar region (dimples 1 and 2 which are the same size as dimples 1 and 2 of the 28-1 ball), and only one size larger spherical dimple 20, i.e. dimple 4 which is the same size as dimple 5 of the 28-1 ball. Thus, the 28-1 ball has some spherical dimples, specifically dimples 6 and 7 in Table 1, which are of larger diameter than any of the spherical dimples 20 of the 25-1 ball.

[0049] FIG. 3 illustrates a mold 23 having one hemisphere of a compression molding cavity 24 designed for making a third embodiment of a ball having a different dimple pattern, identified as dimple pattern or ball 2-9. The cavity 24 has three rows of raised, flattened bumps 25 designed to form three rows of shallow, truncated dimples around the ball's equator, and a polar region having raised, generally hemispherical bumps 26 designed to form deep, spherical dimples in the polar region of ball. The resultant dimple pattern has three rows of shallow truncated dimples around the ball's equator and deep spherical dimples 2 in the polar region of the ball in each hemisphere of the ball. As illustrated in FIG. 3 and shown in Table 3 below, there is only one size of truncated dimple and one size of spherical dimple in the 2-9 dimple pattern. The truncated dimples are identified as dimple #1 in Table 3 below, and the spherical dimples are identified as dimple #2 in Table 3. The 2-9 ball has a total of 336 dimples, with 92 truncated dimples of the same size as the truncated dimples of the 28-1 and 25-1 balls, and 76 deep spherical dimples which are all the same size as the large spherical dimples of the 25-1 ball. Thus, about the same dimple volume is removed around the equator in balls 28-1, 25-1 and 2-9, but more dimple volume is removed in the polar region in ball 28-1 than in balls 25-1 and 2-9, and ball 2-9 has less Volume removed in the polar regions than balls 28-1 and 25-1.

[0050] It will be understood that a similar type of mold, or set of molds, is used for all of the embodiments described herein, and that mold 23 is shown by way of example only.

TABLE 3

Dimple Pattern Design# 2-9 Molding cavity internal diameter = 1.694" Total number of dimples on ball = 336					
Dimple # 1			Dimple # 2		
Type truncated			Type spherical		
Radius 0.0670			Radius 0.0670		
SCD 0.0121			SCD 0.0121		
TCD 0.0039			TCD —		
#	Phi	Theta	#	Phi	Theta
1	0	62.32	1	0	7.91
2	5.58	84.44	2	0	23.57

TABLE 3-continued

Dimple Pattern Design# 2-9 Molding cavity internal diameter = 1.694" Total number of dimples on ball = 336					
Dimple # 1			Dimple # 2		
Type truncated			Type spherical		
Radius 0.0670			Radius 0.0670		
SCD 0.0121			SCD 0.0121		
TCD 0.0039			TCD —		
#	Phi	Theta	#	Phi	Theta
3	5.65	73.68	3	0	41.1
4	13.34	62.32	4	8.38	51.28
5	16.83	73.68	5	12.73	32.35
6	16.84	84.44	6	19.68	42.22
7	26.32	63.12	7	23.8	52.62
8	27.98	73.68	8	25.81	17.69
9	28.24	84.44	9	32.87	28.72
10	38.44	62.01	10	35.9	39.79
11	39.02	73.68	11	37.5	50.83
12	39.4	84.44	12	52.5	50.83
13	50.6	84.44	13	54.1	39.79
14	50.98	73.68	14	57.13	28.72
15	51.56	62.01	15	64.19	17.69
16	61.76	84.44	16	66.2	52.62
17	62.02	73.68	17	70.32	42.22
18	63.68	63.12	18	77.27	32.35
19	73.16	84.44	19	81.62	51.28
20	73.17	73.68	20	90	7.91
21	76.66	62.32	21	90	23.57
22	84.35	73.68	22	90	41.1
23	84.42	84.44	23	98.38	51.28
24	90	62.32	24	102.73	32.35
25	95.58	84.44	25	109.68	42.22
26	95.65	73.68	26	113.8	52.62
27	103.34	62.32	27	115.81	17.69
28	106.83	73.68	28	122.87	28.72
29	106.84	84.44	29	125.9	39.79
30	116.32	63.12	30	127.5	50.83
31	117.98	73.68	31	142.5	50.83
32	118.24	84.44	32	144.1	39.79
33	128.44	62.01	33	147.13	28.72
34	129.02	73.68	34	154.19	17.69
35	129.4	84.44	35	156.2	52.62
36	140.6	84.44	36	160.32	42.22
37	140.98	73.68	37	167.27	32.35
38	141.56	62.01	38	171.62	51.28
39	151.76	84.44	39	180	7.91
40	152.02	73.68	40	180	23.57
41	153.68	63.12	41	180	41.1
42	163.16	84.44	42	188.38	51.28
43	163.17	73.68	43	192.73	32.35
44	166.66	62.32	44	199.68	42.22

TABLE 3-continued

Dimple Pattern Design# 2-9 Molding cavity internal diameter = 1.694" Total number of dimples on ball = 336					
Dimple # 1 Type truncated Radius 0.0670 SCD 0.0121 TCD 0.0039			Dimple # 2 Type spherical Radius 0.0670 SCD 0.0121 TCD —		
#	Phi	Theta	#	Phi	Theta
45	174.35	73.68	45	203.8	52.62
46	174.42	84.44	46	205.81	17.69
47	180	62.32	47	212.87	28.72
48	185.58	84.44	48	215.9	39.79
49	185.65	73.68	49	217.5	50.83
50	193.34	62.32	50	232.5	50.83
51	196.83	73.68	51	234.1	39.79
52	196.84	84.44	52	237.13	28.72
53	206.32	63.12	53	244.19	17.69
54	207.98	73.68	54	246.2	52.62
55	208.24	84.44	55	250.32	42.22
56	218.44	62.01	56	257.27	32.35
57	219.02	73.68	57	261.62	51.28
58	219.4	84.44	58	270	7.91
59	230.6	84.44	59	270	23.57
60	230.98	73.68	60	270	41.1
61	231.56	62.01	61	278.38	51.28
62	241.76	84.44	62	282.73	32.35
63	242.02	73.68	63	289.68	42.22
64	243.68	63.12	64	293.8	52.62
65	253.16	84.44	65	295.81	17.69
66	253.17	73.68	66	302.87	28.72
67	256.66	62.32	67	305.9	39.79
68	264.35	73.68	68	307.5	50.83
69	264.42	84.44	69	322.5	50.83
70	270	62.32	70	324.1	39.79
71	275.58	84.44	71	327.13	28.72
72	275.65	73.68	72	334.19	17.69
73	283.34	62.32	73	336.2	52.62
74	286.83	73.68	74	340.32	42.22
75	286.84	84.44	75	347.27	32.35
76	296.32	63.12	76	351.62	51.28
77	297.98	73.68			

TABLE 3-continued

Dimple Pattern Design# 2-9 Molding cavity internal diameter = 1.694" Total number of dimples on ball = 336					
Dimple # 1 Type truncated Radius 0.0670 SCD 0.0121 TCD 0.0039			Dimple # 2 Type spherical Radius 0.0670 SCD 0.0121 TCD —		
#	Phi	Theta	#	Phi	Theta
78	298.24	84.44			
79	308.44	62.01			
80	309.02	73.68			
81	309.4	84.44			
82	320.6	84.44			
83	320.98	73.68			
84	321.56	62.01			
85	331.76	84.44			
86	332.02	73.68			
87	333.68	63.12			
88	343.16	84.44			
89	343.17	73.68			
90	346.66	62.32			
91	354.35	73.68			
92	354.42	84.44			

[0051] Table 4 below lists dimple shapes, dimensions, and coordinates or locations on a ball for a dimple pattern 28-2 which is very similar to the dimple pattern 28-1 and is therefore not shown separately in the drawings. The ball with dimple pattern 28-2 has three larger spherical dimples of different dimensions, numbered 5, 6 and 7 in Table 4, and three smaller spherical dimples of different dimensions, numbered 1, 2 and 3, and the dimensions of these dimples are identical to the corresponding dimples of the 28-1 ball in Table 1, as are the dimensions of truncated dimples numbered 4 in Table 4. The dimple pattern 28-2 is nearly identical to dimple pattern 28-1, except that the seam that separates the two hemispheres of the ball is wider in the 28-2 ball, and the coordinates of some of the dimples are slightly different, as can be determined by comparing Tables 1 and 4.

[0052] The dimple coordinates for pattern 28-2 are shown in table 4 below.

TABLE 4

Dimple Pattern Design# 28-2 Molding cavity internal diameter = 1.692" Total number of dimples on ball = 410								
Dimple # 1 Type spherical Radius 0.0300 SCD 0.0080 TCD —			Dimple # 2 Type spherical Radius 0.0350 SCD 0.0080 TCD —			Dimple # 3 Type spherical Radius 0.0400 SCD 0.0080 TCD —		
#	Phi	Theta	#	Phi	Theta	#	Phi	Theta
1	0	31.8922591	1	0	15.816302	1	0	0
2	90	31.8922591	2	17.723349	24.952723	2	45	11.14157
3	180	31.8922591	3	25.269266	35.262662	3	45	22.3801
4	270	31.8922591	4	64.730734	35.262662	4	45	33.66965
			5	72.276651	24.952723	5	135	11.14157
			6	90	15.816302	6	135	22.3801
			7	107.72335	24.952723	7	135	33.66965
			8	115.26927	35.262662	8	225	11.14157
			9	154.73073	35.262662	9	225	22.3801
			10	162.27665	24.952723	10	225	33.66965
			11	180	15.816302	11	315	11.14157
			12	197.72335	24.952723	12	315	22.3801
			13	205.26927	35.262662	13	315	33.66965

TABLE 4-continued

Dimple Pattern Design# 28-2								
Molding cavity internal diameter = 1.692"								
Total number of dimples on ball = 410								
			14	244.73073	35.262662			
			15	252.27665	24.952723			
			16	270	15.816302			
			17	287.72335	24.952723			
			18	295.26927	35.262662			
			19	334.73073	35.262662			
			20	342.27665	24.952723			
Dimple # 5			Dimple # 6			Dimple # 7		
Type spherical			Type spherical			Type spherical		
Radius 0.0670			Radius 0.0725			Radius 0.0750		
SCD 0.0121			SCD 0.0121			SCD 0.0121		
TCD —			TCD —			TCD —		
#	Phi	Theta	#	Phi	Theta	#	Phi	Theta
1	12.73	32.2197418	1	0	7.8781502	1	8.38	51.07352
2	77.27	32.2197418	2	0	23.475095	2	23.8	52.40812
3	102.73	32.2197418	3	0	40.93451	3	66.2	52.40812
4	167.27	32.2197418	4	19.68	42.05	4	81.62	51.07352
5	192.73	32.2197418	5	25.81	17.618771	5	98.38	51.07352
6	257.27	32.2197418	6	32.87	28.604358	6	113.8	52.40812
7	282.73	32.2197418	7	35.9	39.629784	7	156.2	52.40812
8	347.27	32.2197418	8	37.5	50.625332	8	171.62	51.07352
			9	52.5	50.625332	9	188.38	51.07352
			10	54.1	39.629784	10	203.8	52.40812
			11	57.13	28.604358	11	246.2	52.40812
			12	64.19	17.618771	12	261.62	51.07352
			13	70.32	42.05	13	278.38	51.07352
			14	90	7.8781502	14	293.8	52.40812
			15	90	23.475095	15	336.2	52.40812
			16	90	40.93451	16	351.62	51.07352
Dimple # 4			Dimple # 4			Dimple # 6		
Type truncated			Type truncated			Type spherical		
Radius 0.0670			Radius 0.0670			Radius 0.0725		
SCD 0.0121			SCD 0.0121			SCD 0.0121		
TCD 0.0039			TCD 0.0039			TCD —		
#	Phi	Theta	#	Phi	Theta	#	Phi	Theta
1	0	62.06907	45	44	106.0691	17	109.68	42.05
2	1	63.06907	46	45	107.0691	18	115.81	17.61877
3	2	64.06907	47	46	108.0691	19	122.87	28.60436
4	3	65.06907	48	47	109.0691	20	125.9	39.62978
5	4	66.06907	49	48	110.0691	21	127.5	50.62533
6	5	67.06907	50	49	111.0691	22	142.5	50.62533
7	6	68.06907	51	50	112.0691	23	144.1	39.62978
8	7	69.06907	52	51	113.0691	24	147.13	28.60436
9	8	70.06907	53	52	114.0691	25	154.19	17.61877
10	9	71.06907	54	53	115.0691	26	160.32	42.05
11	10	72.06907	55	54	116.0691	27	180	7.87815
12	11	73.06907	56	55	117.0691	28	180	23.47509
13	12	74.06907	57	56	118.0691	29	180	40.93451
14	13	75.06907	58	57	119.0691	30	199.68	42.05
15	14	76.06907	59	58	120.0691	31	205.81	17.61877
16	15	77.06907	60	59	121.0691	32	212.87	28.60436
17	16	78.06907	61	60	122.0691	33	215.9	39.62978
18	17	79.06907	62	61	123.0691	34	217.5	50.62533
19	18	80.06907	63	62	124.0691	35	232.5	50.62533
20	19	81.06907	64	63	125.0691	36	234.1	39.62978
21	20	82.06907	65	64	126.0691	37	237.13	28.60436

TABLE 4-continued

Dimple Pattern Design# 28-2								
Molding cavity internal diameter = 1.692"								
Total number of dimples on ball = 410								
22	21	83.06907	66	65	127.0691	38	244.19	17.61877
23	22	84.06907	67	66	128.0691	39	250.32	42.05
24	23	85.06907	68	67	129.0691	40	270	7.87815
25	24	86.06907	69	68	130.0691	41	270	23.47509
26	25	87.06907	70	69	131.0691	42	270	40.93451
27	26	88.06907	71	70	132.0691	43	289.68	42.05
28	27	89.06907	72	71	133.0691	44	295.81	17.61877
29	28	90.06907	73	72	134.0691	45	302.87	28.60436
30	29	91.06907	74	73	135.0691	46	305.9	39.62978
31	30	92.06907	75	74	136.0691	47	307.5	50.62533
32	31	93.06907	76	75	137.0691	48	322.5	50.62533
33	32	94.06907	77	76	138.0691	49	324.1	39.62978
34	33	95.06907	78	77	139.0691	50	327.13	28.60436
35	34	96.06907	79	78	140.0691	51	334.19	17.61877
36	35	97.06907	80	79	141.0691	52	340.32	42.05
37	36	98.06907	81	80	142.0691			
38	37	99.06907	82	81	143.0691			
39	38	100.0691	83	82	144.0691			
40	39	101.0691	84	83	145.0691			
41	40	102.0691	85	84	146.0691			
42	41	103.0691	86	85	147.0691			
43	42	104.0691	87	86	148.0691			
44	43	105.0691	88	87	149.0691			
			89	88	150.0691			
			90	89	151.0691			
			91	90	152.0691			
			92	91	153.0691			

[0053] FIGS. 4 to 6 illustrate hemispheres of three different balls 30, 40 and 50 with different dimple patterns. The dimple patterns on balls 30, 40 and 50 are hereinafter referred to as dimple patterns 25-2, 25-3, and 25-4. Dimple patterns 25-2, 25-3 and 25-4 are related in that they have basically the same design except that each has a different number of rows of truncated dimples surrounding the equator. The dimple dimensions and positions for the balls of FIGS. 4 to 6 are provided below in Tables 5, 6 and 7, respectively.

[0054] Ball 30 or 25-2 of FIG. 4 has two rows of shallow truncated dimples 32 adjacent the equator in each hemisphere (i.e., a total of four rows in the complete ball), and spherical dimples 34 in each polar region. As indicated in Table 5, there are two different sizes of spherical dimples 34, and two different sizes of truncated dimple 32.

[0055] Ball 40 or 25-3 of FIG. 5 has four rows of shallow, truncated dimples 42 adjacent the equator in each hemisphere (i.e. a circumferential band of eight rows of shallow truncated dimples about the equator), and deep spherical dimples 44 in each polar region. As illustrated in FIG. 5 and indicated in Table 6, the truncated dimples 42 are of three different sizes, with the largest size dimples 42A located only in the third and fourth rows of dimples from the equator (i.e. the two rows closest to the polar region). Ball 40 also has spherical dimples with slightly different radii, as indicated in Table 6.

[0056] Ball 50 or 25-4 of FIG. 6 has three rows of shallow, truncated dimples 52 on each side of the equator (i.e. a circumferential band of six rows of dimples around the equator) and deep spherical dimples 54 in each polar region. Ball 50 has spherical dimples of three different radii and truncated dimples which are also of three different radii, as indicated in Table 7. As illustrated in FIG. 6 and indicated in Table 7

below, the third row of truncated dimples, i.e. the row adjacent to the polar region, has some larger truncated dimples 52A, which are three of the largest truncated dimples identified as Dimple #5 in Table 7. The adjacent polar region also has some larger spherical dimples 54A arranged in a generally triangular pattern with the larger truncated dimples, as illustrated in FIG. 6. Dimples 54A are three of the largest spherical dimples identified as Dimple #6 in Table 7. As seen in Table 7, there are twelve total large truncated dimples #5 and twelve total large spherical dimples #6, all with a radius of 0.0875 inches. FIG. 6 illustrates the triangular arrangement of three large truncated dimples and three large spherical dimples at one location. Similar arrangements are provided at three equally spaced locations around the remainder of the hemisphere of the ball illustrated in FIG. 6.

[0057] As indicated in Tables 5, 6, and 7 below, the balls 25-2 and 25-3 each have three different sizes of truncated dimple in the equatorial region and two different sizes of spherical dimple in the polar region, while ball 25-4 has three different sizes of truncated dimple as well as three different sizes of spherical dimple. The polar region of dimples is largest in ball 25-2, which has four rows of truncated dimples (two rows per hemisphere) in the equatorial region, and smallest in ball 25-3, which has eight rows of truncated dimples in the equatorial region. In alternative embodiments, balls may be made with a single row of truncated dimples in each hemisphere, as well as with a land area having no dimples in an equatorial region, the land area or band having a width equal to two, four or more rows of dimples, or with a band having regions with dimples alternating with land regions with no dimples spaced around the equator.

TABLE 5

Dimple Pattern Design# = 25-2
 Molding cavity internal diameter = 1.694"
 Total number of dimples on ball = 336

Dimple # 1 Type truncated Radius 0.0775 SCD 0.0121 TCD 0.0039			Dimple # 2 Type spherical Radius 0.0775 SCD 0.0121 TCD —			Dimple # 3 Type truncated Radius 0.0800 SCD 0.0121 TCD 0.0039		
#	Phi	Theta	#	Phi	Theta	#	Phi	Theta
1	5.579593	73.51994	0	23.4884	1	5.591675	85.23955	
2	16.75313	73.52028	13.0186	32.3247	2	16.84626	85.23955	
3	27.91657	73.52668	19.9156	42.176973		28.29145	85.23955	
4	62.08343	73.52668	24.008	52.436414		39.24409	73.35107	
5	73.24687	73.52628	26.4186	62.928915		39.40674	85.23955	
6	84.42041	73.51994	63.5814	62.928916		50.59326	85.23955	
7	95.57959	73.51994	65.992	52.436417		50.75591	73.35107	
8	106.7531	73.52028	70.0844	42.176978		61.70855	85.23955	
9	117.9166	73.52668	76.9814	32.3247	9	73.15374	85.23955	
10	152.0834	73.52668	90	23.488410		84.40833	85.23955	
11	163.2469	73.52028	103.019	32.32471	1	95.59167	85.23955	
12	174.4204	73.51994	109.916	42.176972		106.8463	85.23955	
13	185.5796	73.51994	114.008	52.436413		118.2915	85.23955	
14	196.7531	73.52028	116.419	62.928914		129.2441	73.35107	
15	207.9166	73.52668	153.581	62.928915		129.4067	85.23955	
16	242.0834	73.52668	155.992	52.436416		140.5933	85.23955	
17	253.2469	73.52028	160.084	42.176977		140.7559	73.35107	
18	264.4204	73.51994	166.981	32.324718		151.7085	85.23955	
19	275.5796	73.51994	180	23.488419		163.1537	85.23955	
20	286.7531	73.52028	193.019	32.324720		174.4083	85.23955	
21	297.9166	73.52668	199.916	42.176971		185.5917	85.23955	
22	332.0834	73.52668	204.008	52.436422		196.8463	85.23955	
23	343.2469	73.52028	206.419	62.928923		208.2915	85.23955	
24	354.4204	73.51994	243.581	62.928924		219.2441	73.35107	
		25	245.992	52.436425		219.4067	85.23955	
		26	250.084	42.176976		230.5933	85.23955	
		27	256.981	32.324727		230.7559	73.35107	
		28	270	23.488428		241.7085	85.23955	
		29	283.019	32.324729		253.1537	85.23955	
		30	289.916	42.176970		264.4083	85.23955	
		31	294.008	52.436431		275.5917	85.23955	
		32	296.419	62.928932		286.8463	85.23955	
		33	333.581	62.928933		298.2915	85.23955	
		34	335.992	52.436434		309.2441	73.35107	
		35	340.084	42.176975		309.4067	85.23955	
		36	346.981	32.324736		320.5933	85.23955	
				37		320.7559	73.35107	
				38		331.7085	85.23955	
				39		343.1537	85.23955	
				40		354.4083	85.23955	
Dimple # 4 Type truncated Radius 0.0800 SCD 0.0121 TCD 0.0039			Dimple # 5 Type spherical Radius 0.0875 SCD 0.0121 TCD —					
#	Phi	Theta	#	Phi	Theta			
1	0	7.947466	1	0	40.85302			
2	26.63272	17.75117	2	0	62.32899			
3	33.30007	28.68155	3	8.422648	51.28898			
4	36.11617	39.79409	4	13.60562	62.53208			
5	37.72952	50.95749	5	76.39438	62.53208			
6	38.62814	62.14951	6	81.57735	51.28898			
7	51.37186	62.14951	7	90	40.85302			
8	52.27048	50.95749	8	90	62.32899			
9	53.88383	39.79409	9	98.42265	51.28898			
10	56.69993	28.68155	10	103.6056	62.53208			
11	63.36728	17.75117	11	166.3944	62.53208			
12	90	7.947466	12	171.5774	51.28898			
13	116.6327	17.75117	13	180	40.85302			
14	123.3001	28.68155	14	180	62.32899			
15	126.1162	39.79409	15	188.4226	51.28898			

TABLE 5-continued

Dimple Pattern Design# = 25-2
Molding cavity internal diameter = 1.694"
Total number of dimples on ball = 336

16	127.7295	50.95749	16	193.6056	62.53208
17	128.6281	62.14951	17	256.3944	62.53208
18	141.3719	62.14951	18	261.5774	51.28898
19	142.2705	50.95749	19	270	40.85302
20	143.8838	39.79409	20	270	62.32899
21	146.6999	28.68155	21	278.4226	51.28898
22	153.3673	17.75117	22	283.6056	62.53208
23	180	7.947466	23	346.3944	62.53208
24	206.6327	17.75117	24	351.5774	51.28898
25	213.3001	28.68155			
26	216.1162	39.79409			
27	217.7295	50.95749			
28	218.6281	62.14951			
29	231.3719	62.14951			
30	232.2705	50.95749			
31	233.8838	39.79409			
32	236.6999	28.68155			
33	243.3673	17.75117			
34	270	7.947466			
35	296.6327	17.75117			
36	303.3001	28.68155			
37	306.1162	39.79409			
38	307.7295	50.95749			
39	308.6281	62.14951			
40	321.3719	62.14951			
41	322.2705	50.95749			
42	323.8838	39.79409			
43	326.6999	28.68155			
44	333.3673	17.75117			

TABLE 6

Dimple Pattern Design# = 25-3
Molding cavity internal diameter = 1.694"
Total number of dimples on ball = 336

Dimple # 1			Dimple # 2			Dimple # 3			Dimple # 4		
Type spherical			Type truncated			Type spherical			Type truncated		
Radius 0.0775			Radius 0.0800			Radius 0.0800			Radius 0.0775		
SCD 0.0121			SCD 0.0121			SCD 0.0121			SCD 0.0121		
TCD —			TCD 0.0039			TCD —			TCD 0.0039		
#	Phi	Theta	#	Phi	Theta	#	Phi	Theta	#	Phi	Theta
1	0	23.4884	1	5.591675	85.23955	1	0	7.947466	1	5.579593	73.51994
2	13.0186	32.3247	2	16.84626	85.23955	2	26.63272	17.75117	2	16.75313	73.52028
3	19.9156	42.17697	3	28.29145	85.23955	3	33.30007	28.68155	3	24.00802	52.43641
4	70.0844	42.17697	4	37.72952	50.95749	4	36.11617	39.79409	4	26.41855	62.92891
5	76.9814	32.3247	5	38.62814	62.14951	5	53.88383	39.79409	5	27.91657	73.52668
6	90	23.4884	6	39.24409	73.35107	6	56.69993	28.68155	6	62.08343	73.52668
7	103.019	32.3247	7	39.40674	85.23955	7	63.36728	17.75117	7	63.58145	62.92891
8	109.916	42.17697	8	50.59326	85.23955	8	90	7.947466	8	65.99198	52.43641
9	160.084	42.17697	9	50.75591	73.35107	9	116.6327	17.75117	9	73.24687	73.52028
10	166.981	32.3247	10	51.37186	62.14951	10	123.3001	28.68155	10	84.42041	73.51994
11	180	23.4884	11	52.27048	50.95749	11	126.1162	39.79409	11	95.57959	73.51994
12	193.019	32.3247	12	61.70855	85.23955	12	143.8838	39.79409	12	106.7531	73.52028
13	199.916	42.17697	13	73.15374	85.23955	13	146.6999	28.68155	13	114.008	52.43641
14	250.084	42.17697	14	84.40833	85.23955	14	153.3673	17.75117	14	116.4186	62.92891
15	256.981	32.3247	15	95.59167	85.23955	15	180	7.947466	15	117.9166	73.52668
16	270	23.4884	16	106.8463	85.23955	16	206.6327	17.75117	16	152.0834	73.52668
17	283.019	32.3247	17	118.2915	85.23955	17	213.3001	28.68155	17	153.5814	62.92891
18	289.916	42.17697	18	127.7295	50.95749	18	216.1162	39.79409	18	155.992	52.43641
19	340.084	42.17697	19	128.6281	62.14951	19	233.8838	39.79409	19	163.2469	73.52028
20	346.981	32.3247	20	129.2441	73.35107	20	236.6999	28.68155	20	174.4204	73.51994
			21	129.4067	85.23955	21	243.3673	17.75117	21	185.5796	73.51994
			22	140.5933	85.23955	22	270	7.947466	22	196.7531	73.52028
			23	140.7559	73.35107	23	296.6327	17.75117	23	204.008	52.43641
			24	141.3719	62.14951	24	303.3001	28.68155	24	206.4186	62.92891
			25	142.2705	50.95749	25	306.1162	39.79409	25	207.9166	73.52668

TABLE 6-continued

Dimple Pattern Design# = 25-3
Molding cavity internal diameter = 1.694"
Total number of dimples on ball = 336

26	151.7085	85.23955	26	323.8838	39.79409	26	242.0834	73.52668
27	163.1537	85.23955	27	326.6999	28.68155	27	243.5814	62.92891
28	174.4083	85.23955	28	333.3673	17.75117	28	245.992	52.43641
29	185.5917	85.23955				29	253.2469	73.52028
30	196.8463	85.23955				30	264.4204	73.51994
31	208.2915	85.23955				31	275.5796	73.51994
32	217.7295	50.95749				32	286.7531	73.52028
33	218.6281	62.14951				33	294.008	52.43641
34	219.2441	73.35107				34	296.4186	62.92891
35	219.4067	85.23955				35	297.9166	73.52668
36	230.5933	85.23955				36	332.0834	73.52668
37	230.7559	73.35107				37	333.5814	62.92891
38	231.3719	62.14951				38	335.992	52.43641
39	232.2705	50.95749				39	343.2469	73.52028
40	241.7085	85.23955				40	354.4204	73.51994
41	253.1537	85.23955						
42	264.4083	85.23955						
43	275.5917	85.23955						
44	286.8463	85.23955						
45	298.2915	85.23955						
46	307.7295	50.95749						
47	308.6281	62.14951						
48	309.2441	73.35107						
49	309.4067	85.23955						
50	320.5933	85.23955						
51	320.7559	73.35107						
52	321.3719	62.14951						
53	322.2705	50.95749						
54	331.7085	85.23955						
55	343.1537	85.23955						
56	354.4083	85.23955						

Dimple # 5
Type truncated
Radius 0.0875
SCD 0.0121
TCD 0.0039

#	Phi	Theta
1	0	62.32899
2	8.42265	51.28898
3	13.6056	62.53208
4	76.3944	62.53208
5	81.5774	51.28898
6	90	62.32899
7	98.4226	51.28898
8	103.606	62.53208
9	166.394	62.53208
10	171.577	51.28898
11	180	62.32899
12	188.423	51.28898
13	193.606	62.53208
14	256.394	62.53208
15	261.577	51.28898
16	270	62.32899
17	278.423	51.28898
18	283.606	62.53208
19	346.394	62.53208
20	351.577	51.28898
21	0	40.85302
22	90	40.85302
23	180	40.85302
24	270	40.85302

TABLE 7

Dimple Pattern Design# = 25-4 Molding cavity internal diameter = 1.694" Total number of dimples on ball = 336											
Dimple # 1 Type truncated Radius 0.0775 SCD 0.0121 TCD 0.0039			Dimple # 2 Type spherical Radius 0.0775 SCD 0.0121 TCD —			Dimple # 3 Type truncated Radius 0.0800 SCD 0.0121 TCD 0.0039			Dimple # 4 Type spherical Radius 0.0800 SCD 0.0121 TCD —		
#	Phi	Theta	#	Phi	Theta	#	Phi	Theta	#	Phi	Theta
1	5.579593	73.5199369	1	0	23.4884	1	5.591675	85.2395467	1	0	7.947466
2	16.75313	73.5202824	2	13.0186	32.3247	2	16.84626	85.2395467	2	26.63272	17.75117
3	26.41855	62.9289055	3	19.9156	42.17697	3	28.29145	85.2395467	3	33.30007	28.68155
4	27.91657	73.5266783	4	24.008	52.43641	4	38.62814	62.1495131	4	36.11617	39.79409
5	62.08343	73.5266783	5	65.992	52.43641	5	39.24409	73.3510713	5	37.72952	50.95749
6	63.58145	62.9289055	6	70.0844	42.17697	6	39.40674	85.2395467	6	52.27048	50.95749
7	73.24687	73.5202824	7	76.9814	32.3247	7	50.59326	85.2395467	7	53.88383	39.79409
8	84.42041	73.5199369	8	90	23.4884	8	50.75591	73.3510713	8	56.69993	28.68155
9	95.57959	73.5199369	9	103.019	32.3247	9	51.37186	62.1495131	9	63.36728	17.75117
10	106.7531	73.5202824	10	109.916	42.17697	10	61.70855	85.2395467	10	90	7.947466
11	116.4186	62.9289055	11	114.008	52.43641	11	73.15374	85.2395467	11	116.6327	17.75117
12	117.9166	73.5266783	12	155.992	52.43641	12	84.40833	85.2395467	12	123.3001	28.68155
13	152.0834	73.5266783	13	160.084	42.17697	13	95.59167	85.2395467	13	126.1162	39.79409
14	153.5814	62.9289055	14	166.981	32.3247	14	106.8463	85.2395467	14	127.7295	50.95749
15	163.2469	73.5202824	15	180	23.4884	15	118.2915	85.2395467	15	142.2705	50.95749
16	174.4204	73.5199369	16	193.019	32.3247	16	128.6281	62.1495131	16	143.8838	39.79409
17	185.5796	73.5199369	17	199.916	42.17697	17	129.2441	73.3510713	17	146.6999	28.68155
18	196.7531	73.5202824	18	204.008	52.43641	18	129.4067	85.2395467	18	153.3673	17.75117
19	206.4186	62.9289055	19	245.992	52.43641	19	140.5933	85.2395467	19	180	7.947466
20	207.9166	73.5266783	20	250.084	42.17697	20	140.7559	73.3510713	20	206.6327	17.75117
21	242.0834	73.5266783	21	256.981	32.3247	21	141.3719	62.1495131	21	213.3001	28.68155
22	243.5814	62.9289055	22	270	23.4884	22	151.7085	85.2395467	22	216.1162	39.79409
23	253.2469	73.5202824	23	283.019	32.3247	23	163.1537	85.2395467	23	217.7295	50.95749
24	264.4204	73.5199369	24	289.916	42.17697	24	174.4083	85.2395467	24	232.2705	50.95749
25	275.5796	73.5199369	25	294.008	52.43641	25	185.5917	85.2395467	25	233.8838	39.79409
26	286.7531	73.5202824	26	335.992	52.43641	26	196.8463	85.2395467	26	236.6999	28.68155
27	296.4186	62.9289055	27	340.084	42.17697	27	208.2915	85.2395467	27	243.3673	17.75117
28	297.9166	73.5266783	28	346.981	32.3247	28	218.6281	62.1495131	28	270	7.947466
29	332.0834	73.5266783	29	219.2441	73.3510713	29	219.2441	73.3510713	29	296.6327	17.75117
30	333.5814	62.9289055	30	219.4067	85.2395467	30	219.4067	85.2395467	30	303.3001	28.68155
31	343.2469	73.5202824	31	230.5933	85.2395467	31	230.5933	85.2395467	31	306.1162	39.79409
32	354.4204	73.5199369	32	230.7559	73.3510713	32	230.7559	73.3510713	32	307.7295	50.95749
			33	231.3719	62.1495131	33	231.3719	62.1495131	33	322.2705	50.95749
			34	241.7085	85.2395467	34	241.7085	85.2395467	34	323.8838	39.79409
			35	253.1537	85.2395467	35	253.1537	85.2395467	35	326.6999	28.68155
			36	264.4083	85.2395467	36	264.4083	85.2395467	36	333.3673	17.75117
			37	275.5917	85.2395467	37	275.5917	85.2395467			
			38	286.8463	85.2395467	38	286.8463	85.2395467			
			39	298.2915	85.2395467	39	298.2915	85.2395467			
			40	308.6281	62.1495131	40	308.6281	62.1495131			
			41	309.2441	73.3510713	41	309.2441	73.3510713			
			42	309.4067	85.2395467	42	309.4067	85.2395467			
			43	320.5933	85.2395467	43	320.5933	85.2395467			
			44	320.7559	73.3510713	44	320.7559	73.3510713			
			45	321.3719	62.1495131	45	321.3719	62.1495131			
			46	331.7085	85.2395467	46	331.7085	85.2395467			
			47	343.1537	85.2395467	47	343.1537	85.2395467			
			48	354.4083	85.2395467	48	354.4083	85.2395467			

Dimple # 5 Type truncated Radius 0.0875 SCD 0.0121 TCD 0.0039			Dimple # 6 Type spherical Radius 0.0875 SCD 0.0121 TCD —		
#	Phi	Theta	#	Phi	Theta
1	0	62.3289928	1	0	40.85302
2	13.60562	62.5320764	2	8.42265	51.28898
3	76.39438	62.5320764	3	81.5774	51.28898
4	90	62.3289928	4	90	40.85302
5	103.6056	62.5320764	5	98.4226	51.28898
6	166.3944	62.5320764	6	171.577	51.28898
7	180	62.3289928	7	180	40.85302

TABLE 7-continued

Dimple Pattern Design# = 25-4 Molding cavity internal diameter = 1.694" Total number of dimples on ball = 336					
8	193.6056	62.5320764	8	188.423	51.28898
9	256.3944	62.5320764	9	261.577	51.28898
10	270	62.3289928	10	270	40.85302
11	283.6056	62.5320764	11	278.423	51.28898
12	346.3944	62.5320764	12	351.577	51.28898

[0058] Dimple patterns 25-2, 25-3 and 25-4 are similar to pattern 2-9 in that they have truncated dimples around the equatorial region and deeper dimples around the pole region, but the truncated dimples in patterns 25-2, 25-3 and 25-4 are of larger diameter than the truncated dimples of patterns 28-1, 25-1 and 2-9. The larger truncated dimples near the equator means that more weight is removed from the equator area. With all other factors being equal, this means that there is a smaller MOI difference between the PH and POP orientations for balls 25-2, 25-3 and 25-4 than for balls 28-1, 28-2, 25-1 and 2-9.

[0059] FIG. 7 illustrates one hemisphere of a golf ball 60 according to another embodiment, which has a different dimple pattern identified as dimple pattern 28-3 in the following description. Dimple pattern 28-3 of ball 60 comprises three rows of truncated dimples 62 on each side of the equator, an area of small spherical dimples 64 at each pole, and an area of larger, deep spherical dimples 65 between dimples 64 and

dimples 62. Table 8 indicates the dimple parameters and coordinates for golf ball 60. As illustrated in Table 8, ball 28-3 has one size of truncated dimple, four sizes of larger spherical dimples (dimple numbers 2, 3, 5 and 6) and one size of smaller spherical dimple (dimple number 1) in the polar regions.

[0060] As indicated in Table 8 and FIG. 7, the small spherical dimples 64 at the pole are all of the same radius, and there are thirteen dimples 64 arranged in a generally square pattern centered on the pole of each hemisphere. There are four different larger spherical dimples 65 (dimple numbers 2 to 6 of Table 8) of progressively increasing radius from 0.075 inches to 0.0825 inches. The ball with dimple pattern 28-3 also has a preferred spin axis through the poles due to the weight difference caused by locating a larger volume of dimples in each polar region than in the equatorial band around the equator.

[0061] The dimple parameters and coordinates for making one hemisphere of the 28-3 ball are listed below in Table 8.

TABLE 8

Dimple Pattern Design# 28-3 Molding cavity internal diameter = 1.692" Total number of dimples on ball = 354								
Dimple # 1 Type spherical Radius 0.0475 SCD 0.0080 TCD —			Dimple # 2 Type spherical Radius 0.0750 SCD 0.0080 TCD —			Dimple # 3 Type spherical Radius 0.0775 SCD 0.0080 TCD —		
#	Phi	Theta	#	Phi	Theta	#	Phi	Theta
1	0	0	1	12.927785	31.884481	0		23.102459
2	0	6.6748046	2	77.072215	31.884482	27.477912	18.124586	
3	0	13.353545	3	102.92779	31.884483	62.522088	18.124586	
4	45	9.4610963	4	167.07221	31.884484	90	23.102459	
5	90	6.6748046	5	192.92779	31.884485	117.47791	18.124586	
6	90	13.353545	6	257.07221	31.884486	152.52209	18.124586	
7	135	9.4610963	7	282.92779	31.884487	180	23.102459	
8	180	6.6748046	8	347.07221	31.884488	207.47791	18.124586	
9	180	13.353545			9	242.52209	18.124586	
10	225	9.4610963			10	270	23.102459	
11	270	6.6748046			11	297.47791	18.124586	
12	270	13.353545			12	332.52209	18.124586	
13	315	9.4610963						
Dimple # 5 Type spherical Radius 0.0800 SCD 0.0080 TCD —			Dimple # 6 Type spherical Radius 0.0825 SCD 0.0080 TCD —					
#	Phi	Theta	#	Phi	Theta			
1	23.959474	52.85795	1	19.446897	42.09101			
2	33.420036	28.804503	2	70.553103	42.09101			
3	36.311426	39.777883	3	109.4469	42.09101			
4	37.838691	50.813627	4	160.5531	42.09101			

TABLE 8-continued

Dimple Pattern Design# 28-3					
Molding cavity internal diameter = 1.692"					
Total number of dimples on ball = 354					
5	52.161309	50.813627	5	199.4469	42.09101
6	53.688574	39.777883	6	250.5531	42.09101
7	56.579964	28.804503	7	289.4469	42.09101
8	66.040526	52.85795	8	340.5531	42.09101
9	113.95947	52.85795	9	0	40.242952
10	123.42004	28.804503	10	90	40.242952
11	126.31143	39.777883	11	180	40.242952
12	127.83869	50.813627	12	270	40.242952
13	142.16131	50.813627	13	8.3680473	51.180102
14	143.68857	39.777883	14	81.631953	51.180102
15	146.57996	28.804503	15	98.368047	51.180102
16	156.04053	52.85795	16	171.63195	51.180102
17	203.95947	52.85795	17	188.36805	51.180102
18	213.42004	28.804503	18	261.63195	51.180102
19	216.31143	39.777883	19	278.36805	51.180102
20	217.83869	50.813627	20	351.63195	51.180102
21	232.16131	50.813627			
22	233.68857	39.777883			
23	236.57996	28.804503			
24	246.04053	52.85795			
25	293.95947	52.85795			
26	303.42004	28.804503			
27	306.31143	39.777883			
28	307.83869	50.813627			
29	322.16131	50.813627			
30	323.68857	39.777883			
31	326.57996	28.804503			
32	336.04053	52.85795			

Dimple # 4		
Type truncated		
Radius 0.0670		
SCD 0.0121		
TCD 0.0039		
#	Phi	Theta
1	0	62.0690668
2	0	83.5
3	5.65	73.3833254
4	11.26	83.5
5	13.34	62.0690668
6	16.83	73.3833254
7	22.66	83.5
8	26.32	62.8658456
9	27.98	73.3833254
10	33.82	83.5
11	38.44	61.760315
12	39.02	73.3833254
13	45	83.5
14	50.98	73.3833254
15	51.56	61.760315
16	56.18	83.5
17	62.02	73.3833254
18	63.68	62.8658456
19	67.34	83.5
20	73.17	73.3833254
21	76.66	62.0690668
22	78.74	83.5
23	84.35	73.3833254
24	90	62.0690668
25	90	83.5
26	95.65	73.3833254
27	101.26	83.5
28	103.34	62.0690668
29	106.83	73.3833254
30	112.66	83.5
31	116.32	62.8658456
32	117.98	73.3833254
33	123.82	83.5
34	128.44	61.760315
35	129.02	73.3833254

TABLE 8-continued

Dimple Pattern Design# 28-3		
Molding cavity internal diameter = 1.692"		
Total number of dimples on ball = 354		
36	135	83.5
37	140.98	73.3833254
38	141.56	61.760315
39	146.18	83.5
40	152.02	73.3833254
41	153.68	62.8658456
42	157.34	83.5
43	163.17	73.3833254
44	166.66	62.0690668
45	168.74	83.5
46	174.35	73.3833254
47	180	62.0690668
48	180	83.5
49	185.65	73.3833254
50	191.26	83.5
51	193.34	62.0690668
52	196.83	73.3833254
53	202.66	83.5
54	206.32	62.86585
55	207.98	73.38333
56	213.82	83.5
57	218.44	61.76032
58	219.02	73.38333
59	225	83.5
60	230.98	73.38333
61	231.56	61.76032
62	236.18	83.5
63	242.02	73.38333
64	243.68	62.86585
65	247.34	83.5
66	253.17	73.38333
67	256.66	62.06907
68	258.74	83.5
69	264.35	73.38333
70	270	62.06907
71	270	83.5
72	275.65	73.38333
73	281.26	83.5
74	283.34	62.06907
75	286.83	73.38333
76	292.66	83.5
77	296.32	62.86585
78	297.98	73.38333
79	303.82	83.5
80	308.44	61.76032
81	309.02	73.38333
82	315	83.5
83	320.98	73.38333
84	321.56	61.76032
85	326.18	83.5
86	332.02	73.38333
87	333.68	62.86585
88	337.34	83.5
89	343.17	73.38333
90	346.66	62.06907
91	348.74	83.5
92	354.35	73.38333

[0062] In one example, the seam widths for balls **28-1**, **28-2**, and **28-3** was 0.0088" total (split on each hemisphere), while the seam widths for balls **25-2**, **25-3**, and **25-4** was 0.006", and the seam width for ball **25-1** was 0.030".

[0063] Each of the dimple patterns described above and illustrated in FIGS. 1 to 7 has less dimple volume in a band around the equator and more dimple volume in the polar region. The balls with these dimple patterns have a preferred spin axis extending through the poles, so that slicing and hooking is resisted if the ball is placed on the tee with the preferred spin axis substantially horizontal. If placed on the

tee with the preferred spin axis pointing up and down (POP orientation), the ball is much less effective in correcting hooks and slices compared to being oriented in the PHI orientation. If desired, the ball may also be oriented on the tee with the preferred spin axis tilted up by about 45 degrees to the right, and in this case the ball still reduces slice dispersion, but does not reduce hook dispersion as much. If the preferred spin axis is tilted up by about 45 degrees to the left, the ball reduces hook dispersion but does not resist slice dispersion as much.

[0064] FIG. 8 illustrates a ball **70** with a dimple pattern similar to the ball **28-1** of FIG. 1 but which has a wider region

or land region 72 with no dimples about the equator. In the embodiment of FIG. 8, the region 72 is formed by removing two rows of dimples on each side of the equator from the ball 10 of FIG. 1, leaving one row of shallow truncated dimples 74. The polar region of dimples is identical to that of FIG. 1, and like reference numbers are used tier like dimples. Rows of truncated dimples may be removed from any of the balls of FIGS. 2 to 7 in a similar manner to leave a dimpleless region or land area about the equator. The dimpleless region in some embodiments may be narrow, like a wider seam, or may be wider by removing one, two, or all of the rows of truncated dimples next to the equator, producing a larger MOI difference between the poles horizontal (PH) and other orientations.

[0065] FIG. 9 is a diagram illustrating the relationship between the chord depth of a truncated and a spherical dimple as used in the dimple patterns of the golf balls described above. A golf ball having a diameter of about 1.68 inches was molded using a mold with an inside diameter of approximately 1.694 inches to accommodate for the polymer shrinkage. FIG. 9 illustrates part of the surface 75 of the golf ball with a spherical dimple 76 of spherical chord depth of d_2 and a radius R represented by half the length of the dotted line. In order to form a truncated dimple, a cut is made along plane A-A to make the dimple shallower, with the truncated dimple having a truncated chord depth of d_1 , which is smaller than the spherical chord depth d_2 . The volume of cover material removed above the edges of the dimple is represented by volume V3 above the dotted line, with a depth d_3 . In FIG. 9,

$V1$ =volume of truncated dimple,

$V1+V2$ =volume of spherical dimple,

$V1+V2+V3$ =volume of cover removed to create spherical dimple, and

$V1+V3$ =volume of cover removed to create truncated dimple.

[0067] The approximate moment of inertia can be calculated for each of the balls illustrated in FIGS. 1 to 7 and in Tables 1 to 8 (i.e. balls 2-9, 25-1 to 25-4, and 28-1 to 28-3). In one embodiment, balls having these patterns were drawn in SolidWorks® and their MOI's were calculated along with the known Polara™ golf ball referenced above as a standard. SolidWorks® was used to calculate the MOI's based on each ball having a uniform solid density of 0.036413 lb/in³. The other physical size and weight parameters for each ball are given in Table 9 below.

TABLE 9

Ball	density,		mass,	volume,	surface	
	lbs/in ³	mass, lbs			grams	inch ³
Polara	0.03613	0.09092	41.28	2.517		13.636
2-9	0.03613	0.09064	41.15	2.509		13.596
25-1	0.03613	0.09060	41.13	2.508		13.611
25-2	0.03613	0.09024243	40.97	2.4979025		13.560402
25-3	0.03613	0.09028772	40.99	2.4991561		13.575728
25-4	0.03613	0.09026686	40.98	2.4985787		13.568852
28-1	0.03613	0.09047	41.07	2.504		13.609
28-2	0.03613	0.09047	41.07	2.504		13.609
28-3	0.03613	0.09053814	41.1	2.5060878		13.556403

[0068] The MOI for each ball was calculated based on the dimple pattern information and the physical information in Table 9. Table 10 shows the MOI calculations.

TABLE 10

Ball	Px, lbs × inch ²	Py, lbs × inch ²	Pz, lbs × inch ²	Pmax	Pmin	MOI Delta = Pmax - Pmin	% (Pmax - Pmin)/Pmax	% MOI delta relative to Polara
Polara	0.025848	0.025917	0.025919	0.025919	0.025848	0.0000703	0.271%	0.0%
2-9	0.025740	0.025741	0.025806	0.025806	0.025740	0.0000665	0.258%	-5.0%
25-1	0.025712	0.025713	0.025800	0.025800	0.025712	0.0000880	0.341%	25.7%
25-2	0.02556791	0.02557031	0.02558386	0.0255839	0.0255679	1.595E-05	0.062%	-77.0%
25-3	0.0255822	0.02558822	0.02559062	0.0255906	0.0255822	8.42E-06	0.033%	-87.9%
25-4	0.02557818	0.02558058	0.02559721	0.0255972	0.0255782	1.903E-05	0.074%	-72.6%
28-1	0.025638	0.025640	0.025764	0.025764	0.025638	0.0001254	0.487%	79.5%
28-2	0.025638	0.025640	0.025764	0.025764	0.025638	0.0001258	0.488%	80.0%
28-3	0.02568461	0.02568647	0.02577059	0.0257706	0.0256846	8.598E-05	0.334%	23.0%

[0066] For dimples that are based on the same radius and spherical chord depth, the moment of inertia difference between a ball with truncated dimples and spherical dimples is related to the volume V2 below line or plane A-A which is removed in forming a spherical dimple and not removed for the truncated dimple. A ball with all other factors being the same except that one has only truncated dimples and the other has only spherical dimples, with the difference between the truncated and spherical dimples being only the volume V2 (i.e. all other dimple parameters are the same), the ball with truncated dimples is of greater weight and has a higher MOI than the ball with spherical dimples, which has more material removed from the surface to create the dimples.

[0069] With the Polara™ golf ball as a standard, the MOI differences between each orientation were compared to the Polara golf ball in addition to being compared to each other. The largest difference between any two orientations is called the "MOI Delta", shown in table 10. The two columns to the right quantify the MOI Delta in terms of the maximum % difference in MOI between two orientations and the MOI Delta relative to the MOI Delta for the Polara ball. Because the density value used to calculate the mass and MOI was lower than the average density of a golf ball, the predicted weight and MOI for each ball is relative to each other, but not exactly the same as the actual MOI values of the golf balls that were made, robot tested and shown in Table 10. Generally a golf ball weighs about 45.5-45.9 g. Comparing the MOI

values of all of the balls in Table 10 is quite instructive, in that it predicts the relative order of MOI difference between the different designs, with the 25-3 ball having the smallest MOI difference and ball 28-2 having the largest MOI difference. [0070] Table 11 shows that a ball's MOI Delta does strongly influence the ball's dispersion control. In general as the relative MOI Delta of each ball increases, the dispersion distance for a slice shot decreases. The results illustrated in Table 11 also include data obtained from testing a known TopFlite XL straight ball, and were obtained during robot testing under standard laboratory conditions, as discussed in more detail below.

[0075] The spin-axis of a golf ball is the axis about which the ball spins and is usually orthogonal to the direction that the golf ball takes in flight. If a golf ball's spin axis is 0 degrees, i.e., a horizontal spin axis causing pure backspin, the ball does not hook or slice and a higher lift force combined with a 0-degree spin axis only makes the ball fly higher. However, when a ball is hit in such a way as to impart a spin axis that is more than 0 degrees, it hooks, and it slices with a spin axis that is less than 0 degrees. It is the tilt of the spin axis that directs the lift three in the left or right direction, causing the ball to hook or slice. The distance the ball unintentionally flies to the right or left is called Carry Dispersion. A lower

TABLE 11

Ball	Orientation	% MOI difference between orientations	Avg C-DISP, ft	Avg C-DIST, yds	Avg T-DISP, ft	Avg T-DIST, yds
28-2	PH	0.488%	9.6	180.6	7.3	201.0
28-1	PH	0.487%	-2.6	174.8	-7.6	200.5
TopFlite XL Straight	random	0.000%	66.5	189.3	80.6	200.4
25-1	PH	0.341%	7.4	184.7	9.6	207.5
28-3	PH	0.334%	16.3	191.8	23.5	211.8
Polara	PFB	0.271%	29.7	196.6	38.0	214.6
2-9	PH	0.258%	12.8	192.2	10.5	214.5
25-4	PH	0.074%	56.0	185.4	71.0	197.3
25-2	PH	0.062%	52.8	187.0	68.1	199.9
25-3	PH	0.033%	63.4	188.0	75.1	197.9

[0071] As illustrated in Table 11, balls 28-3, 25-1, 28-1 and 28-2 all have higher MOI deltas relative to the Polara, and they all have better dispersion control than the Polara. This MOI difference is also shown in FIGS. 10 and 11, which also includes test data for the TopFlite XL Straight made by Callaway Golf.

[0072] The aerodynamic force acting on a golf ball during flight can be broken down into three separate three vectors: Lift, Drag, and Gravity. The lift force vector acts in the direction determined by the cross product of the spin vector and the velocity vector. The drag force vector acts in the direction opposite of the velocity vector. More specifically, the aerodynamic properties of a golf ball are characterized by its lift and drag coefficients as a function of the Reynolds Number (Re) and the Dimensionless Spin Parameter (DSP). The Reynolds Number is a dimensionless quantity that quantifies the ratio of the inertial to viscous forces acting on the golf ball as it flies through the air. The Dimensionless Spin Parameter is the ratio of the golf ball's rotational surface speed to its speed through the air.

[0073] The lift and drag coefficients of a golf ball can be measured using several different methods including an Indoor Test Range such as the one at the USGA Test Center in Far Hills, N.J. or an outdoor system such as the Trackman Net System made by Interactive Sports Group in Denmark. The test results described below and illustrated in FIGS. 10 to 17 for some of the embodiments described above as well as some conventional golf balls for comparison purposes were obtained using a Trackman Net System.

[0074] For right-handed golfers, particularly higher handicap golfers, a major problem is the tendency to "slice" the ball. The unintended slice shot penalizes the golfer in two ways: 1) it causes the ball to deviate to the right of the intended flight path and 2) it can reduce the overall shot distance. A sliced golf ball moves to the right because the ball's spin axis is tilted to the right. The lift force by definition is orthogonal to the spin axis and thus for a sliced golf ball the lift force is pointed to the right.

flying golf ball, i.e., having a lower lift, is a strong indicator of a ball that has lower Carry Dispersion.

[0076] The amount of lift force directed in the hook or slice direction is equal to: Lift Force*Sine (spin axis angle). The amount of lift force directed towards achieving height is: Lift Force*Cosine (spin axis angle).

[0077] A common cause of a sliced shot is the striking of the ball with an open clubface. In this case, the opening of the clubface also increases the effective loft of the club and thus increases the total spin of the ball. With all other factors held constant, a higher ball spin rate in general produces a higher lift force and this is why a slice shot often has a higher trajectory than a straight or hook shot.

[0078] The table below shows the total ball spin rates generated by a golfer with club head speeds ranging from approximately 85-105 mph using a 10.5 degree driver and hitting a variety of prototype golf balls and commercially available golf balls that are considered to be low and normal spin golf balls:

Spin Axis, degree	Typical Total Spin, rpm	Type Shot
-30	2,500-5,000	Strong Slice
-15	1,700-5,000	Slice
0	1,400-2,800	Straight
+15	1,200-2,500	Hook
+30	1,000-1,800	Strong Hook

[0079] FIG. 10 illustrates the average Carry and Total Dispersion versus the MOI difference between the minimum and maximum orientations for each dimple design (random for the TopFlite XL, which is a conforming or symmetrical ball under USGA regulations), using data obtained from robot testing using a Trackman System as referenced above. Balls 25-2, 25-3, and 25-4 of FIG. 10 (also illustrated in FIGS. 4 to 6) are related since they have basically the same dimple pattern except that each has a different number of rows of dimples surrounding the equator, with ball 25-2 having two rows on each side ball 25-3 having four rows, and ball 25-4

having three rows. The % MOI delta between the minimum and maximum orientation for each of these balls obtained from the data in FIG. 10 is indicated in Table 12 below.

TABLE 12

Design #	Rows of truncated around the equator (per hemisphere)	% MOI Delta
25-2	2	0.062%
25-3	4	0.033%
25-4	3	0.074%

[0080] FIG. 11 shows the average Carry and Total Distance versus the MOI difference between the Minimum and Maximum orientations for each dimple design.

[0081] Table 13 below illustrates results from slice testing the 25-1, 28-1, and 2-9 balls as well as the Titleist ProV1 and the TopFlite XL Straight balls, with the 25-1, 28-1 and 2-9 balls tested in both the PH and POP orientations. In this table, the average values for carry dispersion, carry distance, total dispersion, total yards, and roll yards are indicated. This indicates that the 25-1, 28-1 and 2-9 balls have significantly less dispersion in the PH orientation than in the POP orientation, and also have less dispersion than the known symmetrical ProV1 and TopFlite balls which were tested.

TABLE 13

Results from 4-15-10 slice test						
Average Values for TrackMan Data						
Ball Name	Orien-tation	Carry Disper-sion, ft	Carry Dis-tance, yds	Total Dispersion, ft	Total Distance, yds	Roll, yds
25-1	PH	11	197	17	224	25
28-1	PH	-8	194	-5	212	18
2-9	PH	15	202	22	233	30
25-1	POP	39	198	54	215	18
28-1	POP	47	202	62	216	14
2-9	POP	65	194	79	206	13
ProV1	POP	66	197	74	204	7
TopFlite	POP	50	196	69	206	10

[0082] Golf balls 25-1, 28-1, 2-9, Polara 2p 4/08, Titleist ProV1 and TopFlite XL Straight were subjected to several tests under industry standard laboratory conditions to demonstrate the better performance that the dimple patterns described herein obtain over competing golf balls. In these tests, the flight characteristics and distance performance of the golf balls 25-1, 28-1 and 2-9 were conducted and compared with a Titleist Pro V1® made by Acushnet and TopFlite XL Straight made by Callaway Golf and a Polara 2p 4/08 made by Pounce Sports LLC. Also, each of the golf balls 25-1, 28-1, 2-9, Polara 2p 4/08, were tested in the Poles-Forward-Backward (PFB), Pole-Over-Pole (POP) and Pole Horizontal (PH) orientations. The Pro V1® and TopFlite XL Straight are USGA conforming balls and thus are known to be spherically symmetrical, and were therefore tested in no particular orientation (random orientation). Golf balls 25-1 and 28-1 were made from basically the same materials and had a DuPont HPF 2000 based core and a Surlyn™ blend (50% 9150, 50% 8150) cover. The cover was approximately 0.06 inches thick.

[0083] The tests were conducted with a “Golf Laboratories” robot and hit with the same Taylor Made® driver at varying club head speeds. The Taylor Made® driver had a 10.5° R9 460 club head with a Motore 65 “S” shall. The golf

balls were hit in a random order. Further, the balls were tested under conditions to simulate an approximately 15-25 degree slice, e.g., a negative spin axis of 15-25 degrees.

[0084] FIGS. 12 and 13 are examples of the top and side view of the trajectories for individual shots from the Trackman Net system when tested as described above. The Trackman trajectory data in FIGS. 12 and 13 clearly shows the 28-1, 25-1 and 2-9 balls in PH orientation were much straighter (less dispersion) and lower flying (lower trajectory height). The maximum trajectory height data in FIG. 13 correlates directly with the lift coefficient (CL) produced by each golf ball. The results indicate that the Pro V1® and TopFlite XL straight golf ball generated more lift than the 28-1, 25-1 or 2-9 balls in the PH orientation.

Lift and Drag Coefficient Testing & Results, CL and CD Regressions

[0085] FIGS. 14-17 show the lift and drag coefficients (CL and CD) versus Reynolds Number (Re) at spin rates of 3,500 rpm and 4,500 rpm respectively, for the 25-1, 28-1 and 2-9 dimple designs, as well as for the TopFlite® XL Straight, Polara 2p and Titleist Pro V1®. The curves in each graph were generated from the regression analysis of multiple straight shots for each ball design in a specific orientation.

[0086] The curves in FIGS. 14-17 depict the results of regression analysis of many shots over the course of testing done in the period from January through April 2010 under a variety of spin and Reynolds Number conditions. To obtain the regression data shown in FIGS. 14 to 17, a Trackman Net System consisting of 3 radar units was used to track the trajectory of a golf ball that was struck by a Golf Labs robot equipped with various golf clubs. The robot was set up to hit a straight shot with various combinations of initial spin and velocity. A wind gauge was used to measure the wind speed at approximately 20 ft elevation near the robot location. The Trackman Net System measured trajectory data (x, y, z location vs. time) which were then used to calculate the lift coefficients (CL) and drag coefficients (CD) as a function of measured time-dependent quantities including Reynolds Number, Ball Spin Rate, and Dimensionless Spin Parameter. Each golf ball model or design was tested under a range of velocity and spin conditions that included 3,000-5,000 rpm spin rate and 120,000-180,000 Reynolds Number. A 5-term multivariable regression model for the lift and drag coefficients as a function of Reynolds Number (Re) and Dimensionless Spin Parameter (W) was then fit to the data for each ball design: The regression equations for CL and CD were:

$$CL_{Regression} = a_1 * Re + a_2 * W + a_3 * Re^2 + a_4 * W^2 + a_5 * Re * W + a_6$$

$$CD_{Regression} = b_1 * Re + b_2 * W + b_3 * Re^2 + b_4 * W^2 + b_5 * Re * W + b_6$$

Where

[0087] a_i with $i=1-6$ are regression coefficients for Lift Coefficient and

[0088] b_i with $i=1-6$ are regression coefficients for Drag Coefficient

[0089] Typically the predicted CD and CL values within the measured Re and W space (interpolation) were in close agreement with the measured CD and CL values. Correlation coefficients of 96-99% were typical.

[0090] Below in Tables 14A and 14B are the regression constants for each ball shown in FIGS. 14-17. Using these regression constants, the Drag and Lift coefficients can be calculated over the range of 3,000-5,000 rpm spin rate and 120,000-180,000 Reynolds Number. FIGS. 14 to 17 were constructed for a very limited set of spin and Re conditions (3,500 or 4,500 rpm and varying the Re from 120,000 to 180,000), just to provide a few examples of the vast amount of data contained by the regression constants for lift and drag shown in Tables 14A and 14B. The constants can be used to represent the lift and drag coefficients at any point within the space of 3,000-5,000 rpm spin rate and 120,000-180,000 Reynolds Number.

TABLE 14A

Ball Design#	Orientation	Lift Coefficient regression equation coefficient					
		a4	a3	a5	a2	a1	a6
25-1	PH	-0.030201	-3.98E-12	-8.44E-07	0.867344	1.37E-06	-0.087395
25-1	PFB	-2.20008	-3.94E-12	-4.28E-06	2.186681	1.61E-06	-0.129568
28-1	PFB	-1.23292	-6.02E-12	-3.02E-06	1.722214	2.26E-06	-0.177147
28-1	PH	-0.88888	-4.65E-12	-3.49E-06	1.496342	2.15E-06	-0.22382
Polara 2p 4/08	PH	-0.572601	-2.02E-11	-6.63E-06	1.303124	6.1E-06	-0.231079
Polara 2p 4/08	PFB	-1.396513	-7.39E-12	-2.82E-06	1.612026	2.34E-06	-0.140899
Titleist ProV1	na	-0.996621	-4.01E-12	-1.83E-06	1.251743	1.08E-06	0.018157
2-9-121909	PFB	-0.564838	-2.73E-12	8.44E-07	0.592334	1.78E-07	0.161622
2-9-121909	PH	-3.198559	-8.57E-12	-8.56E-06	2.945159	3.57E-06	-0.349143
TopFlite XL-Str	NA	-0.551398	1.48E-12	1.76E-06	0.61879	-1.08E-06	0.222013

TABLE 14B

Ball Design#	Orientation	Drag Coefficient regression equation coefficient					
		b4	b3	b5	b2	b1	b6
25-1	PH	0.369982	-3.16E-12	-1.81E-07	0.278718	9.28E-07	0.139166
25-1	PFB	-0.149176	-1.64E-12	3.04E-07	0.66705	5.35E-07	0.126985
28-1	PFB	0.431796	-1.62E-12	8.56E-07	0.25899	2.76E-07	0.200928
28-1	PH	0.84062	-2.23E-12	8.84E-07	-0.135614	4.23E-07	0.226051
Polara 2p 4/08	PH	-1.086276	4.01E-12	-2.33E-06	1.194892	-2.7E-07	0.157838
Polara 2p 4/08	PFB	-0.620696	-3.52E-12	-1.3E-06	0.965054	1.2E-06	0.043268
Titleist ProV1	na	-0.632946	2.37E-12	7.04E-07	0.761151	-7.41E-07	0.195108
2-9-121909	PFB	-0.822987	1.57E-13	2.61E-06	0.509	-4.46E-07	0.224937
2-9-121909	PH	2.145845	-3.66E-12	-8.88E-07	-0.110029	1.14E-06	0.130302
TopFlite XL-Str	NA	-0.373608	-1.38E-12	1.85E-07	0.663666	3.5E-07	0.14574

[0091] As can be determined from FIGS. 14 to 17, the lift coefficient for balls 25-1, 28-1 and 2-9 in a pole horizontal (PH) orientation is between 0.10 and 0.14 at a Reynolds number (Re) of 180,000 and a spin rate of 3,500 rpm, and between 0.14 and 0.20 at a Re of 120,000 and spin rate of 3,500, which is less than the CL of the other three tested balls (Polara 2p 0408 PH and PFB, Titleist ProV1 and TopFlite XL random orientation). The lift coefficient or CL of the 28-1, 25-1 and 2-9 balls in a PH orientation at a spin rate of 4,500 rpm is between 0.13 and 0.16 at an Re of 180,000 and between 0.17 and 0.25 at an Re of 120,000, as seen in FIG. 15. Drag Coefficients (CD) for the 28-1, 2-9 and 25-1 balls in PH orientation at a spin rate of 3,500 rpm are between 0.23 and 0.26 at an Re of 150,000 and between about 0.24 and 0.27 at an Re of 120,000 as illustrated in FIG. 16. CDs for the same balls at a spin rate of 4,500 rpm (FIG. 17) are about 0.28 to 0.29 at an Re of 120,000 and about 0.23 to 0.26 at an Re of 180,000.

[0092] Under typical slice conditions, with spin rates of 3,000 rpm or greater, the 2-9, 25-1, 28-1 in PH orientation and the Polara 2p in PFB orientation exhibit lower lift coefficients than the commercial balls: ProV1 and TopFlite XL Straight. Lower lift coefficients translate into lower trajectory for straight shots and less dispersion for slice shots. Balls with dimple patterns 2-9, 25-1, 28-1 in PH orientation have approximately 10-40% lower lift coefficients than the ProV1 and TopFlite XL Straight under Re and spin conditions characteristics of slice shots.

[0093] Tables 15-17 are the Trackman Report from the Robot Test. The robot was set up to hit a slice shot with a club path of approximately 7 degrees outside-in and a slightly opened club face. The club speed was approximately 98-100 mph, initial ball spin ranged from about 3,800-5,200 rpm depending on ball construction and the spin axis was approximately 13-21 degrees.

TABLE 15

Shot No	Ball ID w Orientation	ball Design	orient	Club Speed [mph]	Attack Angle [deg]	Club Path [deg]	Vert. Swing Plane [deg]	Horiz. Swing Plane [deg]	Dyn. Loft [deg]	Face Angle [deg]
153	903PH	2-9	H	95.8	-6.1	-6.8	55.7	-11.0	10.5	-4.6
156	902PH	2-9	H	95.1	-6.6	-6.9	55.9	-11.4	10.7	-3.3
158	908PH	2-9	H	99.1	-6.1	-7.0	56.7	-11.0	10.5	-3.7
173	908H	2-9	H	101.9	-6.5	-7.3	56.7	-11.6	10.2	-4.2
175	907H	2-9	H	99.7	-5.5	-7.6	56.4	-11.2	10.4	-3.5
179	902H	2-9	H	96.7	-5.6	-6.5	56.9	-10.2	10.3	-4.4
185	907H	2-9	H	98.7						
191	908H	2-9	H	98.2	-5.9	-7.7	54.9	-11.8	9.8	-3.7
155	904POP	2-9	POP	96.8	-5.7	-7.6	55.6	-11.5	10.2	-4.0
157	906POP	2-9	POP	99.2	-6.0	-7.7	55.4	-11.8	10.6	-4.6

TABLE 15-continued

Shot No	Ball ID w Orientation	ball Design	orient	Club Speed [mph]	Attack Angle [deg]	Club Path [deg]	Vert. Swing Plane [deg]	Horiz. Swing Plane [deg]	Dyn. Loft [deg]	Face Angle [deg]
159	905POP	2-9	POP	98.9	-5.6	-7.7	55.5	-11.5	10.3	-5.0
177	902POP	2-9	POP	98.8	-5.2	-6.8	57.3	-10.1	10.1	-3.9
178	906POP	2-9	POP	99.4	-6.0	-7.6	55.0	-11.8	10.3	-3.7
187	901POP	2-9	POP	98.5	-5.9	-7.8	55.3	-11.8	10.2	-2.7
188	906POP	2-9	POP	101.1	-6.4	-7.4	54.0	-12.1	10.2	-4.5
196	904POP	2-9	POP							
142	505PH	25-1	H	100.1	-6.6	-7.7	54.4	-12.5	10.9	-4.0
143	502PH	25-1	H							
145	506PH	25-1	H	100.3	-5.6	-8.0	55.8	-11.8	10.7	-3.4
149	501PH	25-1	H	98.9	-5.7	-7.5	56.2	-11.3	10.3	-4.9
160	502H	25-1	H	100.0	-6.0	-7.7	55.2	-11.8	10.7	-4.1
163	506H	25-1	H							
165	501H	25-1	H	99.0	-5.7	-7.8	55.9	-11.7	10.1	-4.7
170	505H	25-1	H	100.7	-5.3	-7.9	55.7	-11.5	10.2	-4.3
184	506H	25-1	H	98.8	-5.6	-7.7	55.6	-11.5	10.3	-3.3
186	502H	25-1	H	99.1	-5.7	-7.9	54.7	-11.9	10.4	-4.1
193	502H	25-1	H	98.7	-5.8	-7.5	55.0	-11.6	10.0	-4.3
197	501PH	25-1	H							
224	516H	25-1	H	99.0	-5.7	-7.6	55.4	-11.5	10.5	-4.4
192	503PFB	25-1	PFB	99.6	-5.7	-7.9	54.6	-11.9	10.3	-4.6
141	503POP	25-1	POP	98.9	-5.8	-7.7	56.2	-11.6	11.0	-3.1
144	505POP	25-1	POP	98.8	-5.7	-7.8	55.8	-11.7	11.1	-3.3
150	508POP	25-1	POP	98.8	-5.6	-7.9	56.3	-11.6	10.3	-3.1
151	507POP	25-1	POP	98.9	-5.7	-7.8	55.9	-11.7	11.2	-3.3
161	508POP	25-1	POP	99.5	-5.5	-7.9	54.8	-11.8	10.1	-4.3
162	507POP	25-1	POP	99.1	-5.5	-7.6	55.4	-11.4	10.7	-4.2
166	504POP	25-1	POP	99.0	-5.6	-7.8	55.9	-11.6	10.9	-3.5
171	503POP	25-1	POP	99.0	-5.7	-7.8	56.3	-11.6	10.9	-4.1
182	504P	25-1	POP	98.9	-5.8	-7.8	55.3	-11.8	10.5	-3.4
183	507POP	25-1	POP	98.9	-5.7	-7.8	55.8	-11.7	10.2	-3.5
189	508POP	25-1	POP	99.1	-5.7	-7.5	54.7	-11.6	10.7	-3.3
169	802F	28-1	F	98.3	-5.1	-8.2	56.4	-11.6	10.6	-3.4
231	814F	28-1	F	98.9	-5.7	-7.8	56.0	-11.7	10.9	-3.5
146	803PH	28-1	H	99.2	-5.8	-7.9	56.0	-11.8	10.7	-3.2
167	803H	28-1	H	99.0	-5.4	-7.6	56.0	-11.3	10.4	-3.8
195	803H	28-1	H	98.8	-5.6	-7.7	55.6	-11.5	8.8	-4.0
199	812H	28-1	H	98.8	-6.2	-7.4	54.5	-11.8	9.4	-3.8
208	815H	28-1	H	98.8	-5.9	-7.5	54.9	-11.7	10.5	-4.0
233	811H	28-1	H	99.3	-6.1	-7.4	55.8	-11.6	11.1	-3.6
194	801PFB	28-1	PFB	98.7	-5.5	-7.9	55.0	-11.7	10.4	-4.0
147	802POP	28-1	POP							
148	801POP	28-1	POP	98.8	-5.7	-7.9	56.0	-11.8	10.9	-3.4
164	801POP	28-1	POP	97.6	-6.5	-7.1	55.0	-11.6	10.8	-4.0
181	802POP	28-1	POP	98.5	-5.2	-8.0	56.2	-11.5	10.4	-2.7
205	V140	Titleist ProV1	na	98.8	-5.7	-7.5	54.7	-11.6	10.2	-4.4
212	V92	Titleist ProV1	na	98.8	-5.6	-7.7	54.7	-11.6	10.4	-4.5
219	V95	Titleist ProV1	na	99.3	-5.8	-7.5	54.4	-11.7	10.4	-4.6
237	V76	Titleist ProV1	na	98.9	-6.1	-8.1	54.9	-12.4	10.6	-3.5
241	V180	Titleist ProV1	na	97.6	-5.7	-7.0	56.5	-10.8	11.0	-4.4
243	V97	Titleist ProV1	na	99.3	-5.6	-7.8	56.1	-11.5	10.5	-4.2
198	224	TopFlite XL Straight	na	99.3	-6.3	-7.0	53.4	-11.7	10.3	-4.7
207	225	TopFlite XL Straight	na	98.7	-6.1	-7.6	55.3	-11.8	10.4	-3.6
215	223	TopFlite XL Straight	na	96.5	-5.2	-7.6	56.5	-11.0	10.4	-4.2
222	227	TopFlite XL Straight	na	98.8	-6.2	-6.9	54.1	-11.4	10.2	-4.7
236	185	TopFlite XL Straight	na	98.8	-4.6	-8.7	56.1	-11.8	10.2	-3.3
248	222	TopFlite XL Straight	na	98.9	-7.0	-6.5	56.1	-11.2	10.8	-3.6

TABLE 16

Shot No	Ball Speed [mph]	Smash factor []	Vert. Angle [deg]	Horiz. Angle [deg]	Drag Coef. []	Lift Coef. []	Spin Rate [rpm]	Spin Axis [deg]	Max Height x [yds]	Max Height y [yds]	Max Height z [yds]
153	142.8	1.49	7.6	5.0L	0.26	0.19	4212	21.0	129.9	17.6	0.5L
156	141.2	1.48	8.0	4.0L	0.24	0.16	4048	12.6	129.4	15.9	3.9L
158	141.8	1.43	7.8	4.3L	0.23	0.15	4013	16.1	132.1	15.7	3.5L
173	143.3	1.41	7.4	4.6L	0.27	0.21	4105	19.7	132.6	20.3	2.6R
175	142.0	1.42	7.4	4.4L	0.26	0.18	4459	16.9	132.3	18.1	0.1L

TABLE 16-continued

Shot No	Ball Speed [mph]	Smash factor []	Vert. Angle [deg]	Horiz. Angle [deg]	Drag Coef. []	Lift Coef. []	Spin Rate [rpm]	Spin Axis [deg]	Max Height x [yds]	Max Height y [yds]	Max Height z [yds]
179	141.4	1.46	7.5	5.1L	0.24	0.16	4017	19.3	128.3	15.2	3.0L
185	141.3	1.43	7.7	3.9L	0.25	0.16	3922	16.4	126.7	15.1	2.2L
191	142.5	1.45	7.3	4.3L	0.26	0.17	3899	18.4	131.4	17.1	0.8R
155	143.0	1.48	7.1	4.7L	0.29	0.22	4472	22.1	128.2	19.7	4.9R
157	143.0	1.44	7.9	5.1L	0.28	0.20	3943	22.4	127.6	19.8	3.6R
159	142.4	1.44	7.5	5.5L	0.26	0.21	4063	23.0	130.0	19.7	3.9R
177	142.6	1.44	7.2	4.5L	0.29	0.22	4246	16.9	132.5	22.2	3.5R
178	143.6	1.44	7.3	4.5L	0.30	0.22	4410	23.6	127.8	19.6	6.3R
187	142.0	1.44	7.5	3.6L	0.28	0.21	4142	14.9	136.7	21.9	2.2R
188	142.8	1.41	7.4	5.0L	0.29	0.22	3974	21.2	132.5	22.7	6.4R
196	141.8		7.2	4.4L	0.28	0.23	4190	22.0	131.6	22.5	9.9R
142	144.7	1.45	7.5	4.9L	0.26	0.15	5019	16.0	124.4	14.7	4.1L
143	146.5		7.4	4.3L	0.26	0.16	4903	16.4	127.4	15.7	1.8L
145	146.0	1.46	7.4	4.4L	0.25	0.16	5020	18.7	128.3	15.5	1.8L
149	146.6	1.48	7.2	5.5L	0.27	0.19	4929	16.9	137.1	20.8	0.7L
160	145.5	1.46	7.7	4.9L	0.26	0.14	4644	13.5	122.2	14.3	5.5L
163	145.8		7.1	4.6L	0.25	0.15	4930	16.9	125.6	13.9	3.4L
165	147.0	1.49	7.1	5.4L	0.26	0.18	4717	17.6	139.0	19.7	2.1L
170	146.2	1.45	7.0	5.2L	0.26	0.16	4962	16.2	127.6	15.0	3.7L
184	145.7	1.47	7.0	4.5L	0.27	0.15	4926	15.9	122.4	14.0	2.9L
186	146.1	1.47	7.3	5.0L	0.26	0.14	4628	11.2	119.9	13.4	6.5L
193	146.8	1.49	6.8	5.0L	0.29	0.18	4775	17.7	130.0	17.0	2.1L
197	145.6		7.1	4.9L	0.26	0.17	4612	16.0	135.3	18.4	0.5L
224	146.6	1.48	7.2	5.4L	0.29	0.16	4816	16.5	125.4	15.7	4.7L
192	145.7	1.46	7.0	5.3L	0.29	0.20	4834	16.5	133.2	21.4	1.8R
141	146.9	1.48	7.5	4.1L	0.31	0.21	5169	18.0	132.5	22.1	3.8R
144	145.9	1.48	7.8	4.2L	0.28	0.20	4897	17.6	133.5	21.5	4.0R
150	147.0	1.49	7.1	4.2L	0.30	0.21	4938	14.5	133.5	22.0	1.5R
151	146.1	1.48	7.8	4.4L	0.28	0.19	5122	14.7	134.7	21.2	0.4L
161	146.0	1.47	6.9	5.1L	0.28	0.20	4813	21.3	133.7	19.3	2.4R
162	146.4	1.48	7.3	5.0L	0.29	0.21	5020	17.2	134.5	21.4	1.0R
166	146.8	1.48	7.6	4.6L	0.30	0.20	4993	11.8	133.3	21.6	0.5L
171	147.1	1.48	7.6	4.9L	0.29	0.21	5069	18.9	133.7	21.8	2.9R
182	146.3	1.48	7.3	4.3L	0.28	0.20	4779	19.5	135.3	21.3	6.8R
183	146.1	1.48	7.1	4.3L	0.30	0.21	4871	13.9	136.3	22.8	1.6R
189	145.5	1.47	7.6	4.4L	0.29	0.19	4573	12.5	129.4	19.4	1.9L
169	145.8	1.48	6.9	4.7L	0.31	0.21	5582	20.8	129.5	20.2	5.6R
231	147.2	1.49	7.4	4.5L	0.32	0.22	5353	15.2	130.3	23.5	1.8R
146	146.7	1.48	7.5	4.2L	0.27	0.15	4996	15.1	120.5	14.1	3.5L
167	146.1	1.48	7.3	4.8L	0.28	0.14	4786	16.7	114.3	12.8	4.2L
195	145.6	1.47	7.4	4.5L	0.28	0.14	4612	17.0	109.2	11.8	3.7L
199	145.5	1.47	8.0	4.3L	0.29	0.14	4513	9.8	114.1	13.8	5.6L
208	146.6	1.48	7.3	4.9L	0.29	0.15	4960	12.6	117.0	14.0	5.5L
233	146.5	1.48	7.6	4.5L	0.30	0.16	5181	16.7	119.7	15.1	3.1L
194	146.8	1.49	7.0	4.9L	0.32	0.22	5172	14.7	129.9	23.1	1.4R
147	146.8		7.2	4.0L	0.30	0.19	5045	15.0	132.8	20.3	1.2R
148	146.8	1.49	7.6	4.3L	0.29	0.20	4915	19.8	133.9	21.2	5.5R
164	146.6	1.50	7.5	4.6L	0.28	0.18	4812	15.8	134.9	19.1	0.0R
181	145.4	1.48	7.2	3.8L	0.28	0.19	4748	16.9	131.9	18.8	2.4R
205	144.9	1.47	7.3	5.0L	0.27	0.22	4388	16.6	143.1	26.0	5.2R
212	145.3	1.47	7.3	5.1L	0.28	0.22	4618	15.1	142.7	26.6	3.3R
219	145.1	1.46	7.3	5.2L	0.30	0.23	4534	14.1	139.0	26.4	0.3R
237	145.9	1.48	7.7	4.3L	0.29	0.23	4400	14.3	140.8	28.1	5.5R
241	144.7	1.48	7.9	5.0L	0.29	0.22	4546	18.4	141.3	27.0	8.5R
243	145.4	1.46	7.3	5.0L	0.30	0.24	4834	17.8	139.3	28.0	8.0R
198	145.0	1.46	7.6	5.1L	0.28	0.22	3925	16.4	139.6	26.1	3.3R
207	145.4	1.47	7.6	4.3L	0.29	0.21	4254	14.6	138.9	24.7	4.4R
215	144.5	1.50	7.4	4.9L	0.30	0.23	4412	17.5	139.7	26.4	6.0R
222	145.3	1.47	7.3	5.2L	0.29	0.23	4362	13.3	140.0	27.3	1.0R
236	145.0	1.47	7.4	4.5L	0.29	0.23	4523	13.0	142.9	27.8	4.2R
248	145.3	1.47	7.9	4.1L	0.30	0.24	4424	12.0	138.7	31.0	4.5R

TABLE 17

Shot No	Length [yds]	X [yds]	Side [yds]	Height [yds]	Spin Rate [rpm]	Time [s]	Length [yds]	X [yds]	Side [yds]	Vert. Angle [deg]	Ball Speed [mph]	Spin Rate [rpm]	Flight Time [s]
153	198.4	198.3	5.6R	-0.2		5.13	198.1	198.0	5.5R	-31.3	59.7		5.12
156	203.3	203.3	1.1L	-0.3		5.05	202.8	202.8	1.2L	-27.4	60.0		5.02
158	204.4	204.4	1.7L	-0.2	3180	5.08	204.1	204.1	1.7L	-27.7	59.5	3182	5.07
173	197.6	197.3	10.7R	-0.3	3292	5.35	197.2	196.9	10.7R	-36.1	59.2	3295	5.33
175	197.3	197.2	6.7R	-0.2		5.30	197.0	196.9	6.6R	-33.2	56.9		5.28
179	201.6	201.6	0.7R	-0.2		4.90	201.2	201.2	0.7R	-26.1	63.2		4.89
185	194.3	194.3	0.4R	-0.1		4.88	194.1	194.1	0.4R	-28.2	60.2		4.87
191	190.6	190.4	8.3R	-0.1	3076	5.19	190.6	190.4	8.3R	-35.3	54.4	3076	5.19
155	189.7	188.8	18.3R	0.2	3714	5.21	190.0	189.1	18.3R	-36.1	58.8	3713	5.23
157	191.1	190.2	17.6R	-0.3	3164	5.18	190.7	189.9	17.5R	-35.3	60.2	3166	5.17
159	190.1	189.0	20.2R	0.0	3247	5.17	190.1	189.0	20.2R	-36.6	60.5	3247	5.17
177	191.7	191.2	14.6R	-0.5	3397	5.53	191.2	190.6	14.5R	-41.0	58.3	3401	5.50
178	190.6	189.4	21.2R	0.1	3598	5.21	190.8	189.6	21.3R	-35.5	58.5	3597	5.21
187	198.5	198.2	10.8R	-0.4	3262	5.72	198.1	197.8	10.7R	-40.7	54.1	3264	5.70
188	187.2	185.9	22.1R	0.0	3116	5.65	187.2	185.9	22.1R	-43.9	53.8	3115	5.65
196	186.2	184.0	28.2R	0.2		5.65	186.4	184.2	28.3R	-43.3	54.3		5.66
142	192.7	192.7	1.4L	-0.2		4.80	192.3	192.3	1.4L	-27.0	59.7		4.78
143	195.0	194.9	4.0R	-0.3		4.91	194.4	194.4	3.9R	-28.8	59.6		4.89
145	196.9	196.8	2.8R	-0.2		4.93	196.4	196.4	2.7R	-28.1	59.4		4.91
149	199.0	198.9	6.8R	-0.3	3934	5.56	198.6	198.5	6.8R	-37.7	56.4	3936	5.54
160	192.6	192.6	4.9L	-0.2	3702	4.68	192.3	192.2	4.9L	-25.6	61.8	3704	4.66
163	196.3	196.3	0.1L	-0.2		4.74	195.9	195.9	0.2L	-25.2	60.6		4.73
165	203.3	203.3	2.3R	-0.5	3709	5.60	202.7	202.7	2.3R	-36.1	53.7	3712	5.57
170	196.4	196.4	0.5R	-0.2	3956	4.85	196.0	196.0	0.5R	-27.3	60.5	3958	4.83
184	188.8	188.8	0.3R	-0.2		4.68	188.5	188.5	0.3R	-26.7	58.5		4.67
186	189.2	189.1	7.2L	-0.3	3703	4.50	188.6	188.4	7.3L	-25.0	62.4	3707	4.48
193	192.8	192.8	1.3R	-0.2		5.19	192.5	192.5	1.2R	-33.3	53.4		5.18
197	190.8	190.7	6.8R	-0.2	3587	5.54	190.6	190.4	6.7R	-39.4	49.9	3588	5.53
224	189.9	189.8	4.2L	-0.2	3777	5.00	189.5	189.5	4.2L	-30.9	53.1	3779	4.98
192	187.0	186.3	16.0R	-0.5	3777	5.70	186.5	185.8	15.8R	-43.2	50.7	3781	5.67
141	195.0	194.3	16.7R	-0.2	4093	5.63	194.8	194.1	16.6R	-38.6	55.5	4095	5.62
144	196.4	195.5	19.0R	0.4	3950	5.58	197.0	196.1	19.1R	-37.0	54.4	3948	5.60
150	198.0	197.6	12.6R	-0.5	3920	5.58	197.4	197.0	12.5R	-37.6	56.8	3925	5.55
151	201.0	200.8	8.1R	-0.4	4011	5.65	200.4	200.3	8.0R	-36.6	53.6	4016	5.62
161	196.3	195.8	14.7R	-0.3	3854	5.38	195.9	195.3	14.6R	-35.2	56.8	3856	5.36
162	200.6	200.3	10.4R	-0.4	4008	5.52	200.0	199.8	10.3R	-36.3	58.0	4011	5.50
166	196.2	195.9	9.7R	-0.3	3934	5.62	195.8	195.6	9.6R	-38.4	53.4	3936	5.60
171	200.0	199.4	16.0R	-0.3	4006	5.54	199.7	199.0	16.0R	-37.1	56.3	4009	5.53
182	192.9	191.3	25.5R	0.4	3714	5.69	193.4	191.6	25.7R	-40.1	51.7	3710	5.72
183	193.3	192.9	12.9R	-0.3	3829	5.79	193.0	192.6	12.8R	-42.8	53.8	3831	5.77
189	189.4	189.3	4.9R	-0.1	3545	5.41	189.3	189.2	4.9R	-38.1	49.9	3546	5.40
169	188.3	186.9	22.4R	0.4	4376	5.46	188.8	187.4	22.6R	-37.7	52.7	4371	5.48
231	183.7	183.3	12.7R	-0.2	4123	5.91	183.5	183.1	12.7R	-46.6	46.7	4124	5.90
146	188.9	188.9	1.6L	-0.2	3978	4.55	188.4	188.4	1.7L	-26.2	61.5	3981	4.54
167	178.8	178.7	3.1L	0.2	3846	4.29	179.1	179.1	3.1L	-25.3	61.2	3844	4.30
195	171.5	171.5	1.5L	0.1		4.10	171.7	171.7	1.5L	-24.5	60.5		4.11
199	176.1	175.9	8.1L	0.0	3524	4.49	176.0	175.8	8.1L	-28.8	54.9	3524	4.49
208	178.2	178.1	6.1L	-0.1	3935	4.56	178.2	178.1	6.1L	-29.6	55.2	3935	4.56
233	180.1	180.1	1.0L	0.0		4.75	180.1	180.1	1.0L	-31.9	53.0		4.75
194	185.0	184.6	12.4R	-0.3	4020	5.77	184.7	184.3	12.3R	-44.2	49.7	4023	5.76
147	197.9	197.5	11.8R	-0.6	3957	5.57	197.1	196.7	11.6R	-36.2	53.7	3964	5.53
148	195.7	194.5	21.9R	0.2	3655	5.58	195.9	194.7	22.0R	-38.6	53.2	3652	5.59
164	200.5	200.1	11.7R	-0.4	3760	5.51	199.8	199.5	11.6R	-34.9	53.1	3764	5.48
181	193.3	192.7	14.9R	-0.4	3725	5.41	192.8	192.2	14.8R	-36.1	52.8	3728	5.39
205	198.6	197.6	20.5R	1.6		6.30	200.1	199.0	20.8R	-48.1	47.3		6.40
212	195.9	195.0	18.9R	1.3	3740	6.39	197.1	196.1	19.3R	-47.9	47.8	3731	6.46
219	195.9	195.7	9.2R	-0.3	3695	6.31	195.7	195.5	9.2R	-46.9	48.9	3697	6.29
237	192.8	191.8	19.6R	5.4	3590	6.12	197.8	196.7	20.9R	-48.5	49.9	3547	6.43
241	195.1	193.2	27.4R	0.2	3680	6.46	195.3	193.4	27.4R	-49.8	48.3	3679	6.47
243	184.6	183.1	23.4R	7.8		6.02	191.1	189.4	25.4R	-52.4	47.1		6.48
198	195.3	194.6	16.1R	0.0	3231	6.24	195.3	194.6	16.1R	-47.0	50.0	3231	6.24
207	197.7	196.5	21.1R	0.2		6.24	197.9	196.8	21.1R	-43.5	48.4		6.25
215	194.8	193.5	22.2R	-0.6	3582	6.32	194.3	193.1	22.0R	-48.6	50.8	3585	6.29
222	195.7	195.3	12.5R	-0.4	3564	6.41	195.3	195.0	12.4R	-48.4	49.3	3566	6.39
236	199.5	198.4	20.6R	0.5	3622	6.51	199.9	198.9	20.8R	-48.0	48.4	3618	6.54
248	191.2	190.3	18.5R	0.1	3613	6.60	191.3	190.4	18.5R	-51.4	50.9	3612	6.61

[0094] The non-conforming golf balls described above which have dimple patterns including areas of less dimple volume along at least part of a band around the equator and more dimple volume in the polar regions have a large enough

moment of inertia (MOI) difference between the poles horizontal (PH) or maximum orientation and other orientations that the ball has a preferred spin axis extending through the poles of the ball. As described above, this preferred spin axis

helps to prevent or reduce the amount of hook or slice dispersion when the ball is hit in a way which would normally produce hooking or slicing in a conventional, symmetrically designed golf ball. This reduction in dispersion is illustrated for the embodiments described above in FIG. 10 and for some of the embodiments in FIG. 12. Although a preferred spin axis may alternatively be established by placing high and low density materials in specific locations within the core or intermediate layers of a golf ball, such construction adds cost and complexity to the golf ball manufacturing process. In contrast, balls having the different dimple patterns described above can be readily manufactured by suitable design of the hemispherical mold cavities, for example as illustrated in FIG. 3 for a 2-9 ball.

[0095] Although the illustrated embodiments all have, reduced dimple volume in a band around the equator as compared to the dimple volume in the polar regions, other dimple patterns which generate preferred spin axis may be used in alternative embodiments to achieve similar results. For example, the low volume dimples do not have to be located in a continuous band around the ball's equator. The low volume dimples could be interspersed with larger volume dimples about the equator, the band could be wider in some parts of the circumference than others, part of the band could be dimpleless around part or all of the circumference, or there may be no dimples at all around the equatorial region. Another embodiment may comprise a dimple pattern having two or more regions of lower or zero dimple volume on the surface of the ball, with the regions being somewhat co-planar. This also creates a preferred spin axis. In one example, if the two areas of lower volume dimples are placed opposite one another on the ball, then a dumbbell-like weight distribution is created. This results in a ball with a preferred spin axis equal to the orientation of the ball when rotating end-over-end with the "dumbbell" areas.

[0096] Although the dimples in the embodiments illustrated in FIGS. 1 to 8 and described above are all circular dimples, it will be understood that there is a wide variety of types and construction of dimples, including non-circular dimples, such as those described in U.S. Pat. No. 6,409,615, hexagonal dimples, dimples formed of a tubular lattice structure, such as those described in U.S. Pat. No. 6,290,615, as well as more conventional dimple types. It will also be understood that any of these types of dimples can be used in conjunction with the embodiments described herein. As such, the term "dimple" as used in this description and the claims that follow is intended to refer to and include any type or shape of dimple or dimple construction, unless otherwise specifically indicated.

[0097] The above description of the disclosed embodiments is provided to enable any person skilled in the art to make or use the invention. Various modifications to these embodiments will be readily apparent to those skilled in the art, and the generic principles described herein can be applied to other embodiments without departing from the spirit or scope of the invention. Thus, it is to be understood that the description and drawings presented herein represent a presently preferred embodiment of the invention and are therefore representative of the subject matter which is broadly contemplated by the present invention. It is further understood that the scope of the present invention fully encompasses other embodiments that may become obvious to those skilled in the art and that the scope of the present invention is accordingly limited by nothing other than the appended claims.

1. A golf ball mold having a surface that comprises a plurality of bumps configure to form a plurality of dimples on the outer surface of a golf ball made using the mold, the mold surface comprising one or more first areas which include a plurality of first bumps which together produce a first dimple

volume and at least one second area that will produce a dimple volume less than the first dimple volume, the first and second areas being configured to establish a preferred spin axis and a gyroscopic center plane for the golf ball such that the gyroscopic center plane does not go through all of the areas.

2. The golf ball mold of claim 1, wherein the first and second areas define a non-conforming dimple pattern.

3. The golf ball mold of claim 1, wherein the second area comprises a band around the equator of the golf ball and the one or more first areas comprise polar regions of the golf ball.

4. The golf ball mold of claim 3, wherein the band comprises at least two rows of bumps that define second dimples, one row being located on each side of an equatorial plane associated with the golf ball.

5. The golf ball mold of claim 3, wherein the band comprises between two and eight rows of bumps that define second dimples.

6. The golf ball mold of claim 1, wherein the at least one second area is within the 45 degree position with respect to the gyroscopic center plane.

7. The golf ball mold of claim 6, wherein the one or more first areas are outside of the 45 degree position with respect to the gyroscopic center plane.

8. The golf ball mold of claim 4, wherein the bumps define second dimples that are of smaller volume than at least some of the first dimples.

9. The golf ball mold of claim 8, wherein the bumps define first dimples that are spherical dimples and second dimples that are truncated dimples.

10. The golf ball mold of claim 9, wherein the truncated chord depth of the truncated dimples is less than the spherical chord depth of the spherical dimples.

11. The golf ball mold of claim 10, wherein the truncated dimples have a radius which is the same as the radius of at least some of the spherical dimples.

12. The golf ball mold of claim 11, wherein the truncated chord depth is less than half of the spherical chord depth.

13. The golf ball mold of claim 10, wherein the truncated chord depth of each truncated dimple is approximately 0.004 inches and the spherical chord depth of each spherical dimple is approximately 0.012 inches.

14. The golf ball mold of claim 8, wherein the bumps define first dimples and second dimples that are truncated dimples.

15. The golf ball mold of claim 8, wherein the bumps define first dimples and second dimples that are spherical dimples.

16. The golf ball mold of claim 3, wherein the bumps define dimples in the polar regions that are of at least two different sizes.

17. The golf ball mold of claim 16, wherein the bumps define dimples in the polar regions that are of at least three different sizes.

18. The golf ball mold of claim 3, wherein at least some of the bumps define dimples in the polar regions that have radii in a first range from approximately 0.067 inches to approximately 0.0875 inches.

19. The golf ball mold of claim 18, wherein all of the dimples in the polar regions have radii in the first range.

20. The golf ball mold of claim 3, wherein the bumps define dimples in the polar regions that comprise a first set of spherical dimples having radii in a first range and a second set of spherical dimples having radii in a second range smaller than the radii in the first range.

21. The golf ball mold of claim 20, wherein the second range of radii is from approximately 0.03 inches to approximately 0.04 inches.

22. The golf ball mold of claim 20, wherein the bumps define a second set of spherical dimples that are all the same size.

23. The golf ball mold of claim 20, wherein the bumps define a second set of spherical dimples that include dimples of at least two different sizes.

24. The golf ball mold of claim 23, wherein the humps define a second set of spherical dimples that includes dimples of three different sizes.

25. The golf ball mold of claim 20, wherein the bumps define a first set of spherical dimples that are all the same size.

26. The golf ball mold of claim 20, wherein the bumps define a first set of spherical dimples that comprise dimples of at least two different radii.

27. The golf ball mold of claim 26, wherein the bumps define a first set of spherical dimples that comprise dimples having a plurality of different radii between a smallest dimple radius and a largest dimple radius.

28. The golf ball mold of claim 27, wherein the majority of dimples in the first set have a radius between the smallest and largest dimple radius.

29. The golf ball mold of claim 27, wherein there are more dimples of the largest dimple radius than the smallest dimple radius.

30. The golf ball mold of claim 3, wherein the bumps that define dimples in the polar regions are the same size.

31. The golf ball mold of claim 20, wherein the bumps define at least some dimples of the second set that have a radius which is approximately half the radius of at least some dimples of the first set.

32. The golf ball mold of claim 20, wherein humps define dimples of the second set that have a radius in the range from approximately 0.030 to 0.040 inches and dimples of the first set that have a radius in the range from approximately 0.065 to 0.075 inches.

33. The golf ball mold of claim 31, wherein the second set of dimples comprises dimples having diameters of approximately 0.030, 0.035 and 0.040 inches and the first set of dimples comprises dimples having diameters of approximately 0.067, 0.0725 and 0.075 inches.

34. The golf ball mold of claim 20, wherein the second set of dimples each have a spherical chord depth of approximately 0.008 inches and the first set of dimples each have a spherical chord depth of approximately 0.012 inches.

35. The golf ball mold of claim 20, wherein the bumps define dimples of the second set that are interspersed between at least some of the dimples of the first set.

36. The golf ball mold of claim 35, wherein the bumps define dimples of the second set that are interspersed between dimples of the first set closer to the poles, and at least one area of each polar region extending around the ball adjacent a band around the equator that contains only dimples of the first set.

37. The golf ball mold of claim 20, wherein the bumps define a second set of dimples that are located around the respective pole and a first set of dimples that are located between the second set of dimples and the reduced volume band around the equator.

39. The golf ball mold of claim 9, wherein the bumps define first and second dimples that each include a plurality of different size dimples.

40. The golf ball mold of claim 3, wherein the bumps define a band around the equator that includes a dimpleless area.

41. The golf ball mold of claim 40, wherein the bumps define a band around the equator that contains no dimples.

42. The golf ball mold of claim 40, wherein the dimpleless area extends around the equator and is centered on the equatorial plane, and the bumps define a band that includes at least one row of dimples extend around the ball on each side of the dimpleless area.

43. The golf ball mold of claim 3, wherein the total number of bumps is between 336 and 410.

44. The golf ball mold of claim 3, wherein the total number of bumps in the band around the equator is between 184 and 240.

45. The golf ball mold of claim 44, wherein the total number of bumps in one polar region is between 48 and 113.

46. The golf ball of claim 9, wherein the bumps define dimples in the band around the equator that are truncated and that have a radius less than that of at least some of the dimples formed in the polar regions and that have a truncated chord depth no more than half the spherical chord depth of the dimples formed in the polar region.

47. The golf ball of claim 1, wherein the mold comprises a compression molded cavity.

48. The golf ball mold of claim 47, wherein the mold comprises two hemispheres.

49. A golf ball mold having an outer surface that comprises a plurality of bumps configured to form a plurality of dimples formed on the outer surface of a golf ball made using the mold, the mold surface comprising one or more first areas which include a plurality of first bumps which together produce a first dimple volume and at least one second area that produces a dimple volume less than the first dimple volume, the first and second areas being configured to establish a preferred spin axis and a gyroscopic center plane for the golf ball such that the at least one second area is formed about the gyroscopic center plane.

* * * * *