

(12) INTERNATIONAL APPLICATION PUBLISHED UNDER THE PATENT COOPERATION TREATY (PCT)

(19) World Intellectual Property Organization
International Bureau



(43) International Publication Date
23 October 2003 (23.10.2003)

PCT

(10) International Publication Number
WO 03/087895 A1

(51) International Patent Classification⁷: G02B 5/128

(21) International Application Number: PCT/US03/03907

(22) International Filing Date: 11 February 2003 (11.02.2003)

(25) Filing Language: English

(26) Publication Language: English

(30) Priority Data:
10/122,527 11 April 2002 (11.04.2002) US

(71) Applicant: 3M INNOVATIVE PROPERTIES COMPANY [US/US]; 3M Center, Post Office Box 33427, Saint Paul, MN 55133-3427 (US).

(72) Inventors: BUDD, Kenton, D.; Post Office Box 33427, Saint Paul, MN 55133-3427 (US). FREY, Matthew, H.; Post Office Box 33427, Saint Paul, MN 55133-3427 (US).

(74) Agents: WRIGHT, Bradford, B. et al.; Office of Intellectual Property Counsel, Post Office Box 33427, Saint Paul, MN 55133-3427 (US).

(81) Designated States (national): AE, AG, AL, AM, AT (utility model), AT, AU, AZ, BA, BB, BG, BR, BY, BZ, CA, CH, CN, CO, CR, CU, CZ (utility model), CZ, DE (utility model), DE, DK (utility model), DK, DM, DZ, EC, EE (utility model), EE, ES, FI (utility model), FI, GB, GD, GE, GH, GM, HR, HU, ID, IL, IN, IS, JP, KE, KG, KP, KR, KZ, LC, LK, LR, LS, LT, LU, LV, MA, MD, MG, MK, MN,

MW, MX, MZ, NO, NZ, OM, PH, PL, PT, RO, RU, SC, SD, SE, SG, SK (utility model), SK, SL, TJ, TM, TN, TR, TT, TZ, UA, UG, UZ, VC, VN, YU, ZA, ZM, ZW.

(84) Designated States (regional): ARIPO patent (GH, GM, KE, LS, MW, MZ, SD, SL, SZ, TZ, UG, ZM, ZW), Eurasian patent (AM, AZ, BY, KG, KZ, MD, RU, TJ, TM), European patent (AT, BE, BG, CH, CY, CZ, DE, DK, EE, ES, FI, FR, GB, GR, HU, IE, IT, LU, MC, NL, PT, SE, SI, SK, TR), OAPI patent (BF, BJ, CF, CG, CI, CM, GA, GN, GQ, GW, ML, MR, NE, SN, TD, TG).

Declarations under Rule 4.17:

— as to applicant's entitlement to apply for and be granted a patent (Rule 4.17(ii)) for the following designations AE, AG, AL, AM, AT, AU, AZ, BA, BB, BG, BR, BY, BZ, CA, CH, CN, CO, CR, CU, CZ, DE, DK, DM, DZ, EC, EE, ES, FI, GB, GD, GE, GH, GM, HR, HU, ID, IL, IN, IS, JP, KE, KG, KP, KR, KZ, LC, LK, LR, LS, LT, LU, LV, MA, MD, MG, MK, MN, MW, MX, MZ, NO, NZ, OM, PH, PL, PT, RO, RU, SC, SD, SE, SG, SK, SL, TJ, TM, TN, TR, TT, TZ, UA, UG, UZ, VC, VN, YU, ZA, ZM, ZW, ARIPO patent (GH, GM, KE, LS, MW, MZ, SD, SL, SZ, TZ, UG, ZM, ZW), Eurasian patent (AM, AZ, BY, KG, KZ, MD, RU, TJ, TM), European patent (AT, BE, BG, CH, CY, CZ, DE, DK, EE, ES, FI, FR, GB, GR, HU, IE, IT, LU, MC, NL, PT, SE, SI, SK, TR), OAPI patent (BF, BJ, CF, CG, CI, CM, GA, GN, GQ, GW, ML, MR, NE, SN, TD, TG)

[Continued on next page]

(54) Title: METHOD OF MAKING RETROCHROMIC BEADS AND KIT THEREOF

(57) Abstract: The present invention provides a method of making a plurality of intrinsically retrochromic beads. The present invention further provides a kit comprising intrinsically retrochromic beads having different retroreflective colors.

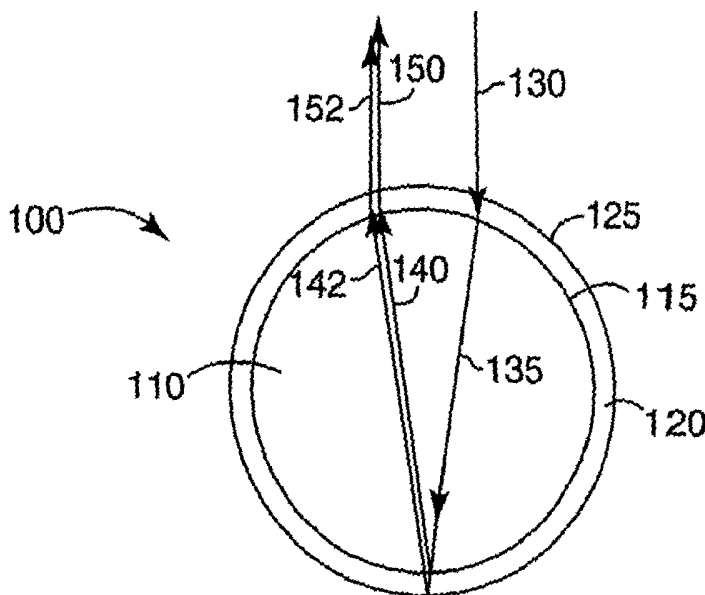

WO 03/087895 A1



— *as to the applicant's entitlement to claim the priority of the earlier application (Rule 4.17(iii)) for all designations*

For two-letter codes and other abbreviations, refer to the "Guidance Notes on Codes and Abbreviations" appearing at the beginning of each regular issue of the PCT Gazette.

Published:

— *with international search report*

METHOD OF MAKING RETROCHROMIC BEADS AND KIT THEREOF

BACKGROUND

The present invention relates generally to retroreflective beads that cause a change in color of retroreflected light, methods of making same, and articles containing same.

"Retroreflectivity" means the ability, if engaged by a beam of light, to reflect that light substantially back in the direction of the light source. Films, for example, transparent adhesive-backed overlay films, having covert retroreflective patterns have been used to authenticate security articles (for example, passports, identification badges). Typically, such overlay films have covert retroreflective patterns that are not readily legible under conditions of diffuse illumination, but become readily legible if viewed in retroreflective mode (for example, with a flashlight or specialized device such as a retroviewer).

Depending on the application, the addition of covert color to retroreflective articles may provide additional security features (for example, as in the case of authentication of passports or identification badges), or novel visual effects (for example, as used in the design and production of graphic articles).

As used herein, the term "retrochromism" refers to the ability of an object, or region of an object, if viewed in retroreflective mode (that is, with the illumination source substantially co-linear with the line of sight, typically forming an angle of reflection of 10 degrees or less), to exhibit a reflected color different from the color exhibited if the object or region is viewed in other than retroreflective mode. Various constructions that exhibit retrochromism are known. For example, in one such construction high refractive index glass beads are partially embedded in a layer of or layers of material(s) (for example, including a dielectric mirror). A change in color of retroreflected light results from the interaction of light, the bead, and the layer(s) into which it is partially embedded. Such articles may be prone to loss of, or irregularity in, their retrochromism due to coating thickness variations of the layer(s) and differences in the depth of penetration of the beads into the layer(s). Such articles may further be prone to damage caused by flexing the article during usage, or if used as heat-shrink tamper indicating films. Further, it would be laborious and difficult to prepare such retrochromic articles with complex patterns of multiple retroreflective colors.

Such drawbacks could be overcome using retrochromic beads that are retrochromic, regardless of orientation or position. Thus, it would be desirable to have simple, economical methods for preparing such intrinsically retrochromic beads in a wide variety of retroreflective colors. It would also be desirable to have a kit comprising intrinsically retrochromic beads wherein the beads could be blended to achieve custom retroreflective colors.

SUMMARY

In one aspect, the present invention provides a method of making intrinsically retrochromic beads comprising:

providing a fluidized bed of beads;

depositing a concentric optical interference layer onto the respective surface of each of a plurality of beads to form a plurality of coated beads; and

removing a first portion of coated beads from the fluidized bed,

wherein the concentric optical interference layers comprising the first portion have a first average thickness, and wherein the first portion comprises intrinsically retrochromic beads.

In some embodiments, the deposition of the concentric optical interference layer can be monitored by viewing the coated beads in retroreflective mode.

In another aspect, the present invention provides a kit comprising a first plurality of intrinsically retrochromic beads having a first average retroreflective color, a second plurality of intrinsically retrochromic beads having a second average retroreflective color, and a third plurality of intrinsically retrochromic beads having a third average retroreflective color, wherein said retroreflective colors are distinct and comprise a retroreflective color palette.

In yet another aspect, the present invention provides a method of preparing a plurality of retroreflective beads having a custom retroreflective color comprising:

providing a first plurality of intrinsically retrochromic beads having a first average retroreflective color;

providing a second plurality of intrinsically retrochromic beads having a second average retroreflective color; and

combining, with mixing, said first and second pluralities of retrochromic beads.

According to the various aspects of the present invention, intrinsically retrochromic beads having a wide range of retrochromic colors may be easily and economically prepared. Such beads are useful for applications including, for example, authentication of security documents and in the graphic arts.

The following definitions are used throughout the specification and claims:

"Intrinsically retrochromic bead" means a bead that exhibits retrochromism, in substantially all orientations, if immersed in its entirety in at least one isotropic medium.

"Light" refers to electromagnetic radiation having one or more wavelengths in the visible (that is, from 400 nm to 700 nm), ultraviolet (that is, from 200 nm to 400 nm), and/or infrared (that is, from 700 nm to 100 micrometers) regions of the electromagnetic spectrum.

"Metal oxide" refers to a material made up primarily of one or more types of metal and/or metalloid cations and oxygen, and which may contain minor amounts of other elements and compounds.

"Refractive index" refers to the index of refraction at a wavelength of 589.3 nanometers (that is, nm) corresponding to the sodium yellow d-line, and a temperature of 20 °C, unless otherwise specified.

"Retrochromic" means that the object being referred to exhibits retrochromism.

"Retrochromic pattern" refers to a pattern comprising one or more retrochromic regions.

"Retroreflective color" refers to the appearance of retroreflected light. As used throughout the specification and claims, differences between retroreflective colors are to be determined using the same illumination source.

"Retroreflective color palette" refers to at least three retroreflective colors, wherein the difference spectra associated with the retroreflective colors exhibit relative maxima or minima that are spaced apart by at least 20 nanometers in wavelength. "Difference spectra" refers to the difference in the intensity versus wavelength spectra of the illumination source and the retroreflected light after each of said spectra is normalized so that the maximum intensity is defined to be 100 percent.

"Viewable" means visually observable at some distance from the object being viewed.

"Viewable region" refers to a portion of an object having a boundary or general extent that is substantially apparent or discernible to a viewer.

BRIEF DESCRIPTION OF THE DRAWINGS

FIG. 1 is a cross-sectional representation of a Type I retrochromic bead depicting exemplary paths of retroreflected light.

FIG. 2 is a flow diagram of an exemplary process, according to the present invention, for making Type I retrochromic beads.

DETAILED DESCRIPTION

Intrinsically retrochromic beads may, for example, be of at least two types, referred to herein as Type I and Type II intrinsically retrochromic beads.

Type I Intrinsically Retrochromic Beads

Referring now to **FIG. 1**, a Type I intrinsically retrochromic bead **100** comprises a transparent substantially spherical core **110** having thereon a concentric optical interference layer **120** having an exterior surface **125**. Core **110** contacts optical interference layer **120** at interface **115**.

Typically, concentric optical interference layer **120** forms a substantially uniform and complete layer over the entire surface of spherical core **110**. Desirably, the concentric optical interference layer is uniform and complete, however minor imperfections in the layer (for example, pinholes and/or minor thickness fluctuations) may be tolerated as long as they are not of sufficient size or amount to render the bead not intrinsically retrochromic.

Light is typically reflected at interfaces between materials having differing refractive indices (for example, having a difference in refractive indices of at least 0.1). Thus, a sufficient difference in the refractive indices of the core **110** and substantially transparent optical interference layer **120** gives rise to a first reflection at interface **115**. Similarly, a sufficient difference in the refractive indices of optical interference layer **120** and any background medium (for example, vacuum, gas, liquid, solid) contacting optical interference layer **120** gives rise to a second reflection at exterior surface **125**. Through proper selection of the thickness and refractive index of the optical interference layer, the

two reflections may optically interfere with each other, resulting in a retroreflected color different from that which would otherwise be observed in the absence of such interference.

For example, retrochromic behavior can result from destructive interference of a portion of the optical spectrum determined by the thickness and refractive index of the optical interference layer. This effect is visible primarily if viewed in retroreflective mode, and is substantially not observable if viewed in other than retroreflective mode.

Referring again to **FIG. 1**, light **130** that is incident on Type I intrinsically retrochromic bead **100** is largely transmitted through optical interference layer **120**, and enters core **110**. A portion of the incident light **130** may be reflected at exterior surface **125** or interface **115**. Retroreflection results from the portion of light **130** which enters core **110** and is at least partially focused by refraction onto the back of core **110**. As refracted light **135** encounters interface **115** at the back of core **110**, some of refracted light **135** is reflected back as reflected light **140** towards the front of the bead where it ultimately emerges from the bead as retroreflected light **150** in a direction that is substantially anti-parallel to incident light **130**. Similarly, another portion of the focused light passes through optical interference layer **120** and is reflected back as reflected light **142** at exterior surface **125**, which forms an interface with whatever medium in which the Type I intrinsically retrochromic bead **100** is disposed (for example, gas, liquid, solid, or vacuum). Reflected light **142** ultimately emerges from the bead as retroreflected light **152** in a direction that is substantially anti-parallel to incident light **130**. Remaining light that is not reflected passes entirely through the intrinsically retrochromic bead. Interference between reflected light **140** and reflected light **142**, and in turn retroreflected light **150** and retroreflected light **152**, gives rise to a change in color of the retroreflected light. For example, subtraction of wavelengths from the center of the spectrum of incident white light results in retroreflected light with a red-violet hue (that is, retrochromism). Slightly thicker optical interference layers subtract longer wavelengths, resulting in, for example, green or blue-green hues.

Since reflection at an interface between two materials is dependent on the difference in refractive indices of the two materials, there is no inherent need to use cores and/or the optical interference layers comprising either high or low refractive index materials, as long as a sufficient difference in refractive indices is maintained. The difference in refractive indices of core **110** and optical interference layer **120**, and the

difference in refractive indices of optical interference layer **120** and the medium in which the retrochromic bead is intended to be used should be at least 0.1, desirably at least 0.2, more desirably at least 0.3, and most desirably at least 0.4. The refractive index of optical interference layer **120** may be either greater than or less than the refractive index of core **110**. Generally, the choice of refractive index, and the corresponding choice of materials used, will be determined by the specific choice of the medium that contacts the exterior surface **125** in the region where reflection is intended to occur.

The refractive indices of core **110**, concentric optical interference layer **120**, and the medium in which the intrinsically retrochromic bead is intended to be used are desirably selected so as to control the focal power of the bead and the strength of reflections from interfaces **115** and **125**. Color saturation of retroreflected light is typically maximized if the index of refraction differences at interfaces **115** and **125** are balanced (that is, substantially equal). If index of refraction differences at the two interfaces are not balanced, retroreflected light typically appears pale or "washed out." At the same time, brightness of retroreflected color is typically maximized if balanced index of refraction differences are as large as possible.

In order to obtain a high level of retroreflectivity, it is typically desirable to select a core **110** having a relatively high index of refraction, desirably greater than 1.5, more desirably greater than 1.8. This allows the incident light to be at least partially focused onto the back of core **110** (that is, the side opposite the source of incident light).

For example, a glass bead having a diameter in the range of 20 to 200 micrometers and refractive index of 1.9 and an air-exposed surface is typically a highly efficient retroreflective microlens for incident visible light. If a glass bead having a refractive index of 1.9 is coated with a thin layer of silica (that is, an optical interference layer) with refractive index of about 1.4, the coated bead in air has a glass bead-silica layer interface with a refractive index difference of about 0.5 and a silica layer-air interface with an refractive index difference of about 0.4. Such coated beads can produce strong color effects if viewed using a retroviewer. However, if such coated beads are partially embedded in an organic material having an index of refraction much closer to that of the silica layer, the index difference at the silica layer-background medium interface becomes very low and color saturation and retroreflected intensity are dramatically reduced.

An optical interference layer comprising a high index of refraction such as titania can be used to provide significant index differences at both interfaces for this type of construction. Multilayer coatings can also be used to adjust the interference effect, or to simply fix the index differences of the interfaces (for example, by using a much thicker outer coating).

The thickness of the concentric optical interference layer can, desirably, be selected to produce a pre-determined color effect.

Light that is reflected at an interface may be reflected with or without a phase inversion. Light that passes through a medium having a higher index of refraction and encounters an interface with a medium having a lower index of refraction will be reflected without phase inversion. By contrast, light that passes through a medium having a lower index of refraction and encounters an interface with a medium having a higher index of refraction will be reflected with phase inversion. Consequently, the appropriate choice of optical interference layer thickness will depend on the refractive index of core **110**, the refractive index of the optical interference layer **120**, and the refractive index of intended medium in which it is to be disposed. In any case, the thickness should be selected such that the reflected light from exterior surface **125** is π radians (that is, 180°) out of phase with light of the same wavelength reflected from interface **115**.

If the refractive index of the bead is greater than the refractive index of the optical interference layer, which in turn is greater than the refractive index of the medium, destructive interference typically occurs, for example, if the optical interference layer **120** has an optical thickness (that is, thickness divided by refractive index) that is an odd multiple of one quarter of the wavelength (that is, quarter wave) to be subtracted. By way of illustration, for such a relationship of refractive indices, an optical interference layer thickness of 137.5 nm may result in a red-violet hue if viewed in retroreflective mode using white light illumination. As the optical interference layer thickness increases, the destructive center moves toward longer wavelengths, and blue, blue-green, and yellow-green retroreflected colors are progressively observed.

If the refractive index of the bead is less than the refractive index of the optical interference layer, which in turn is greater than the refractive index of the medium, destructive interference typically occurs if the optical interference layer **120** has an optical thickness that is a multiple of one half of the wavelength to be subtracted.

Although the number of possible permutations of refractive indices, extra layers, and layer thicknesses is quite large, the specific choice of refractive indices and thicknesses will be readily apparent to one of ordinary skill in the art upon review of the forgoing discussion.

Type I intrinsically retrochromic beads may be conveniently, and economically, prepared using a fluidized bed of transparent beads and vapor deposition techniques. In general, the processes of depositing vapor phase materials onto a fluidized (that is, agitated) bed of a plurality of beads, as used herein, can be collectively referred to as "vapor deposition processes" in which a concentric layer is deposited on the surface of respective transparent beads from a vapor form. In some embodiments, vapor phase precursor materials are mixed in proximity to the transparent beads and chemically react *in situ* to deposit a layer of material on the respective surfaces of the transparent beads. In other embodiments, material is presented in vapor form and deposits as a layer on the respective surfaces of the transparent beads with essentially no chemical reaction.

Depending upon the deposition process being used, precursor material(s) (in the case of a reaction-based deposition process) or layer material(s) (in the case of a non-reaction-based process), typically in vapor phase, is or are placed in a reactor with transparent beads. The present invention desirably utilizes a vapor phase hydrolysis reaction to deposit a concentric optical interference layer (for example, a layer of metal oxide) onto the surface of a respective core. Such process is sometimes referred to as a chemical vapor deposition ("CVD") reaction.

Desirably, a low temperature, atmospheric pressure chemical vapor deposition ("APCVD") process is used. Such processes do not require vacuum systems and can provide high coating rates. Hydrolysis-based APCVD (that is, APCVD wherein water reacts with a reactive precursor) is most desired because of the ability to obtain highly uniform layers at low temperatures, for example, typically well below 300 °C.

The following is an illustrative vapor phase hydrolysis-based reaction:

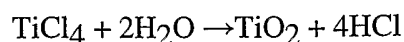

In the illustrative reaction, water vapor and titanium tetrachloride, taken together, are considered metal oxide precursor materials.

Useful fluidized bed vapor deposition techniques are described, for example, in U.S. Pat. No. 5,673,148 (Morris et al.).

A well-fluidized bed can ensure that uniform layers are formed both for a given particle and for the entire population of particles. In order to form substantially continuous layers covering essentially the entire surfaces of the transparent beads, the transparent beads are suspended in a fluidized bed reactor. Fluidizing typically tends to effectively prevent agglomeration of the transparent beads, achieve uniform mixing of the transparent beads and reaction precursor materials, and provide more uniform reaction conditions, thereby resulting in highly uniform concentric optical interference layers. By agitating the transparent beads, essentially the entire surface of each assembly is exposed during the deposition, and the assembly and reaction precursors or layer material may be well intermixed, so that substantially uniform and complete coating of each bead is achieved.

If using transparent beads that tend to agglomerate, it is desirable to coat the transparent beads with fluidizing aids, for example, small amounts of fumed silica, precipitated silica, methacrylate chromic chloride having the trade designation "VOLAN" (available from Zaclon, Inc., Cleveland, OH). Selection of such aids and of useful amounts thereof may be readily determined by those with ordinary skill in the art.

One technique for getting precursor materials into the vapor phase and adding them to the reactor is to bubble a stream of gas, desirably a non-reactive gas, referred to herein as a carrier gas, through a solution or neat liquid of the precursor material and then into the reactor. Exemplary carrier gases include argon, nitrogen, oxygen, and/or dry air.

Optimum flow rates of carrier gas(es) for a particular application typically depend, at least in part, upon the temperature within the reactor, the temperature of the precursor streams, the degree of assembly agitation within the reactor, and the particular precursors being used, but useful flow rates may be readily determined by routine optimization techniques. Desirably, the flow rate of carrier gas used to transport the precursor materials to the reactor is sufficient to both agitate the transparent beads and transport optimal quantities of precursor materials to the reactor.

Referring to **FIG. 2**, wherein an exemplary process for making intrinsically retrochromic beads is shown, carrier gas **202** is bubbled through water bubbler **204**, to produce water vapor-containing precursor stream **208**. Carrier gas **202** is also bubbled through titanium tetrachloride bubbler **206**, to produce titanium tetrachloride-containing precursor stream **230**. Precursor streams **208** and **230** are then transported into reactor

220. Cores **110** are introduced into reactor **220**, and intrinsically retrochromic beads **100** are removed therefrom.

Typically, precursor flow rates are adjusted to provide an adequate deposition rate and to provide a metal oxide layer of desired quality and character. Desirably, flow rates are adjusted such that the ratios of precursor materials present in the reactor chamber promote metal oxide deposition at the surface of the transparent beads with minimal formation of discrete, that is, free floating, metal oxide particles, elsewhere in the chamber. For example, if depositing layers of titania from titanium tetrachloride and water, a ratio of between about eight water molecules per each titanium tetrachloride molecule to one water molecule per two titanium tetrachloride molecule is generally suitable, with about two water molecules of water per titanium tetrachloride molecule being preferred. Under these conditions there is sufficient water to react with most of the titanium tetrachloride and most of the water is adsorbed onto the surface of the retroreflective bead. Much higher ratios tend to yield substantial quantities of non-adsorbed water that might result in formation of oxide particulates rather than the desired oxide layers.

Desirably, precursor materials have sufficiently high vapor pressures that sufficient quantities of precursor material will be transported to the reactor for the hydrolysis reaction and layer deposition process to proceed at a conveniently fast rate. For instance, precursor materials having relatively higher vapor pressures typically provide faster deposition rates than precursor materials having relatively lower vapor pressures, thereby enabling the use of shorter deposition times. Precursor sources may be cooled to reduce vapor pressure or heated to increase vapor pressure of the material. The latter may necessitate heating of tubing or other means used to transport the precursor material to the reactor, to prevent condensation between the source and the reactor. In many instances, precursor materials will be in the form of neat liquids at room temperature. In some instances, precursor materials may be available as sublimable solids.

Precursor materials that are capable of forming dense metal oxide coatings via hydrolysis reactions at temperatures below 300 °C, and typically below 200 °C, are desired for coating glass beads. Desirably, titanium tetrachloride and/or silicon tetrachloride, and water are used as precursor materials. In addition to volatile metal chlorides, useful precursor materials include, for example, mixtures of water and at least one of: metal

alkoxide(s) (for example, titanium isopropoxide, silicon ethoxide, zirconium n-propoxide), metal alkyl(s) (for example, trimethylaluminum, diethylzinc). It may be desirable to utilize several precursors simultaneously in a coating process.

Desirably, mutually reactive precursor materials, for example, TiCl_4 and H_2O , are not mixed prior to being added to the reactor in order to prevent premature reaction within the transport system. Accordingly, multiple gas streams into the reaction chamber are typically provided.

Vapor deposition processes include hydrolysis based CVD and/or other processes. In such processes, the beads are typically maintained at a temperature suitable to promote effective deposition and formation of the concentric optical interference layer with desired properties on the beads. Increasing the temperature at which the vapor deposition process is conducted typically yields a resultant concentric layer that is denser and retains fewer fugitive unreacted precursors. Sputtering or plasma-assisted chemical vapor deposition processes, if utilized, often require minimal heating of the article being coated, but typically require vacuum systems, and can be difficult to use if coating particulate materials such as small glass beads.

Typically, a deposition process that operates at a temperature low enough not to undesirably degrade the transparent beads should be selected. Thus, deposition of the optical interference layer is desirably achieved using a hydrolysis-based APCVD process at temperatures below $300\text{ }^\circ\text{C}$, more desirably below $200\text{ }^\circ\text{C}$.

Titania and titania-silica layers deposited from tetrachlorides are particularly desired, and are easily deposited by APCVD at low temperatures, for example, between $120\text{ }^\circ\text{C}$ and $160\text{ }^\circ\text{C}$.

Typically, any dimensionally stable substantially spherical transparent bead may be used as a core in practice of the present invention. Cores may be inorganic, polymeric or other provided that they are substantially transparent to at least one wavelength, desirably all wavelengths, of visible light. Typically, cores have a diameter of from 20 to 500 micrometers, desirably from 50 to 100 micrometers, although other diameters are possible.

Desirably, cores comprise a material, desirably an inorganic glass comprising silica, having a refractive index of from 1.5 to 2.5 or even higher, desirably from 1.7 to 1.9. Cores may also have a lower refractive index value depending on the particular

intended application, and the composition of the concentric optical interference layer. For example, a silica glass bead with refractive index as low as 1.50 may be desirably used as a core because of the low cost and high availability of soda-lime-silica (that is, window glass). Optionally, cores may further comprise a colorant. Desirably, cores comprise glass.

Exemplary materials that may be utilized as a core include glasses (for example, mixtures of metal oxides such as SiO_2 , B_2O_3 , TiO_2 , ZrO_2 , Al_2O_3 , BaO , SrO , CaO , MgO , K_2O , Na_2O); and solid, transparent, non-vitreous, ceramic particles as described in, for example, U.S. Pat. Nos. 4,564,556 (Lange) and 4,758,469 (Lange).

Exemplary useful colorants include transition metals, dyes, and/or pigments, and are typically selected according to compatibility with the chemical composition of the core, and the processing conditions utilized.

The concentric optical interference layer employed in practice according to the present invention may be of any transparent material having a different refractive index than the core supporting the layer. Desirably, the concentric optical interference layer should be sufficiently smooth so as to be optically clear. Desirably, the concentric optical interference layer is tough, and not easily chipped or flaked.

Desirably, the concentric optical interference layer comprises a metal oxide. Exemplary metal oxides useful for the concentric optical interference layer include titania, alumina, silica, tin oxide, zirconia, antimony oxide, and mixed oxides thereof. Desirably, the optical interference layer comprises one of the following: titanium dioxide, silicon dioxide, aluminum oxide, or a combination thereof. Titania and titania/silica layers are most desired, as they are readily deposited and form durable layers.

Advantageously, portions of retrochromic beads having various optical interference layer thicknesses and retroreflective colors can be removed from a reactor sequentially. One, two, three, or more pluralities of retrochromic coated beads, each plurality having a different retroreflective color and collectively comprising a retroreflective color palette, may thus be easily obtained by charging a reactor with a large quantity of beads and sequentially removing two, three, or more portions of beads during a continued coating run, each portion comprising beads and having a larger average optical interference layer thickness than the preceding portion.

In one desirable embodiment, the progress of layer deposition may be monitored by viewing the beads in retroreflective mode, for example, by using a retroviewer (for example, as described in U.S. Pat. Nos. 3,767,291 (Johnson) and 3,832,038 (Johnson), either *in situ* using a glass-walled reactor or by removal from the reactor. Retroviewers useful for viewing intrinsically retrochromic beads and articles containing them are also readily commercially available, for example, under the trade designation "3M VIEWER" from 3M Company, St. Paul, MN.

Type II Intrinsically Retrochromic Beads

Intrinsically retrochromic beads of Type II comprise partially transparent beads having microcrystalline regions therein. The microcrystalline regions are of a size typically less than the wavelength range of visible light. The microcrystalline regions scatter light of different wavelengths in the visible spectrum to different degrees. The microcrystalline regions scatter light on the short end of the visible wavelength spectrum more effectively than they scatter light on the long end of the visible wavelength spectrum. If the shorter wavelength components of the incident spectrum are preferentially scattered, the longer wavelength components are transmitted within the bead and, ultimately retroreflected. Typically, the microcrystalline regions have a size in the range of from 10 to 500 nm. Desirably, the microcrystalline regions have a size of from 50 to 250 nm, with substantially no microcrystalline regions being larger than 250 nm.

The retroreflected spectrum is modified, as compared with the incident spectrum. Modification of the spectrum refers to a change imparted to the relative intensities of the different incident wavelengths. Typically, for incident light that is white, colorless Type II retrochromic beads retroreflect light that is essentially yellow, orange, or red. Light-scattering inside the bead causes a modification of the retroreflected spectrum as compared with the incident spectrum. For crystallites grown to the size range of 50 to 250 nm, yellow, orange, or red light is transmitted within the bead and eventually retroreflected, while light of wavelengths near the violet end of the visible spectrum is preferentially scattered from the retroreflective light path. Preferential scattering of wavelengths near the violet end of the visible spectrum causes their subtraction from the incident spectrum, and thus they are not retroreflected.

In one exemplary method, Type II intrinsically retrochromic beads can be made as follows. First, an aqueous slurry is prepared from particulate components comprising at least two metal oxides. Optionally, an inorganic oxide dopant that imparts color to the finished bead by light absorption (for example, a colorant) may also be present in the slurry. Desirably, particulate components of the slurry should be chosen such that upon melting and rapid quenching an amorphous transparent bead is formed. The transparent bead may contain small crystals (for example, less than 10 nm), but the composition should be selected such that it crystallizes slowly enough that it can be quenched to form a glassy material.

Metal oxides useful for forming Type II intrinsically retrochromic beads are well known in the art. Exemplary metal oxides include SiO_2 , Al_2O_3 , B_2O_3 , Na_2O , K_2O , CaO , MgO , BaO , SrO , TiO_2 , ZrO_2 . Certain metal oxides are known as strong glass-formers (for example, SiO_2 , GeO_2 , As_2O_5 , P_2O_5 , B_2O_3). A strong glass-former is a metal oxide that can be relatively easily quenched into a solid amorphous state from the melt. Desirably, particulate components of the slurry comprise a strong glass-former. Metal oxides that do not readily form glasses by themselves may be incorporated into Type II intrinsically retrochromic beads, if used in combination with certain species (known as intermediates) and strong glass-formers. Exemplary intermediates include Al_2O_3 and PbO . Al_2O_3 may be incorporated into Type II intrinsically retrochromic beads if, for example, it is added to a strong glass-former (for example, SiO_2) in combination with a modifier metal oxides. Such modifiers include, for example, alkali metal oxides and alkaline earth oxides (for example, Na_2O , K_2O , MgO , CaO , SrO , BaO).

Certain metal oxides, (for example, TiO_2 , ZrO_2) may serve to nucleate crystallization if included in glass compositions. Such metal oxides are useful, for example, as nucleating agents for subsequent crystallization of the glass with heat-treatment.

Advantageously, flame-forming processes used to form Type II intrinsically retrochromic beads allow the use of a wider range of glass compositions than could be formed by traditional processes for the fabrication of glass articles. For example, compositions high in TiO_2 and ZrO_2 (for example, greater than 50 weight percent) would typically be considered inappropriate, as oxide melts which are very high in TiO_2 and/or

ZrO₂ tend to form crystals during cooling. However, in the preparation of Type II intrinsically retrochromic beads, it is desirable to include at least one nucleating agent in the aqueous slurry such as, for example, titanium oxide or zirconium oxide.

As an additional feature, the rapid quench rates that are typical of the flame-forming process for manufacturing glass beads enable the preparation of a wider range of compositions as glasses than could be formed using slower cooling rate processes. In particular, eutectic compositions of traditionally non-glass-forming oxides can be prepared as glass beads. Thus, it is desirable that particulate metal oxide components in the slurry be present in approximately eutectic proportions.

The fact that compositions generally not expected to form glasses can be formed as glass beads opens up the range of compositions that are potentially useful for the formation of Type II microcrystalline retrochromic beads. Accordingly, the range of useful compositions is not limited to the compositions generally regarded as convenient for forming glasses or even glass-ceramics.

Desirably, microcrystalline retrochromic beads include a glass-forming metal oxide. For example, SiO₂ can aid in initial glass-forming, if included in the bead in an amount, for example, in the range of from 2 to 40 percent by weight based on the total weight of the bead. To generate a high density of microcrystals during heat-treatment, nucleating agents (for example, TiO₂ and/or ZrO₂) are useful at levels ranging from greater than 5 but less than 80 percent by weight based on the total weight of the bead. TiO₂ and ZrO₂ are also useful for achieving a high index of refraction (1.8-2.3). A high index of refraction is useful for strong retroreflection.

Additional constituents that may be present in microcrystalline intrinsically retrochromic beads include, for example, B₂O₃, Al₂O₃, MgO, CaO, BaO, Na₂O, and K₂O. The alkali metal oxides and alkaline earth oxides are especially useful for reducing the melting temperature of the composition, and can be included at a combined alkali metal oxide and alkaline earth oxide content of up to 25 percent by weight of the total combined weight of the microcrystalline intrinsically retrochromic bead.

Desirably, if high levels (that is, > 60 percent by weight based on the total weight of the bead) of TiO₂ are included in the Type II intrinsically retrochromic bead composition, alkaline earth oxides are included at levels of greater than 10 percent by

weight based on the total weight of the bead, and aid in quenching transparent beads during the flame-forming process.

The slurry is then typically milled and dried to form a powder cake, then ground into particles. Particles are fed into the flame of a hydrogen/oxygen torch where they melt and form intermediate beads as described in, for example, U.S. Pat. No. 6,245,700 (Budd et al.). Intermediate beads are rapidly cooled (that is, quenched), for example in a water tank to form vitreous beads. Cooled vitreous beads may, optionally, be passed a second time through the hydrogen torch to improve their transparency.

Next, cooled vitreous beads are placed into a crucible (for example, an alumina crucible), and heated in a furnace by slowly ramping the temperature (for example, at a rate of 10 °C/minute) up to a temperature sufficient to devitrify them. The elevated temperature should be high enough to cause devitrification of the vitreous beads, but not so high that the beads fuse together. Desirably the elevated temperature is in the range of from 400 °C to 1200 °C, more desirably from 700 °C to 1100 °C. Elevated temperature is maintained for a sufficient time to substantially devitrify the beads, desirably a period ranging from 15 to 120 minutes. Subsequently, the temperature is reduced back to room temperature.

Desirably, the amount of colorant is in the range of from 0.01 to 5 weight percent, and more desirably in the range of from 0.5 to 3 weight percent, based on the total weight of the metal oxide components.

Appropriate processing conditions for generating Type II intrinsically retrochromic beads from transparent beads having a given chemical composition can be readily determined as follows.

In a first procedure, separate portions of beads are heat-treated, for example, by placing them into a furnace with a ramp rate of 10 °C/min up to a number of equally spaced temperatures ranging from room temperature to the melting point of the composition. Such spacing between heat-treatment temperatures may be, for example, 50 °C or 100 °C. Once each portion of beads reaches its desired temperature (that is, soak temperature), it is maintained at that temperature for a period of time that is identical for all portions, for example, one hour. The portions are removed from the furnace and cooled to room temperature. With increasing soak temperature, for compositions that

crystallize before melting, there is typically a progression from transparency to opacity for the heat-treated beads.

If none of the processed portions of the first procedure display the desired retrochromic effect, the procedure is repeated with soak temperatures ranging from the highest temperature at which transparent beads were observed to the lowest temperature at which opaque beads were observed. In this second procedure, soak temperatures spaced by, for example, 5 °C or 10 °C, produce a series of heat-treated bead samples that more closely resolve the transition between a state of high transparency and a state of opacity.

If none of the processed portions of the second procedure display the desired retrochromic effect, a third procedure carried out with soak temperatures ranging from the highest temperature at which transparent beads were observed to the lowest temperature at which opaque beads were observed in the second procedure. In this third procedure, soak temperatures are spaced by, for example, 1 °C or 2 °C.

Once appropriate conditions are found, the length of the soak time may be further adjusted in order to finely control the size of the microcrystalline regions.

Regardless of whether intrinsically retrochromic beads are of Type I or Type II, the magnitude of the retrochromic effect typically depends on the spectral breadth of source used to illuminate the retrochromic bead. Desirably, the source has a broad spectrum (for example, white light), although narrower spectral ranges may also be used.

Whichever type(s) of intrinsically retrochromic bead(s) is/are used in practice of the present invention, the magnitude of retroreflection may be increased by coating onto the intrinsically retrochromic bead an integral hemispherical reflector as described in, for example, U.S. Pat. No. 2,963,378 (Palmquist et al.).

Advantageously, pluralities of intrinsically retrochromic beads having different retroreflective colors may be combined with a holder to form a kit. Desirably, the retroreflective colors are chosen such that they form a retroreflective color palette if viewed using white light illumination. In some embodiments, the retroreflective color palette includes at least three of violet, blue, green, orange, yellow, red, or green retroreflective colors if viewed using white light illumination. In some embodiments, the retroreflective color palette may comprise yellow, magenta, and cyan retroreflective colors, if viewed using white light illumination.

The kit may comprise, for example, pluralities of different intrinsically retrochromic beads corresponding to different retroreflective colors that are collectively, and separately, contained within at least one reclosable container. For example, a box may have compartments in which individual pluralities of intrinsically retrochromic beads having different retroreflective colors are confined.

In some embodiments, pluralities of intrinsically retrochromic beads may be confined in separate containers, desirably reclosable containers, and assembled as a group with a holder, desirably a holder adapted to receive the separate containers. Exemplary holders include a box, a blister pack, a rack (for example, a test tube rack), and a bag.

In some embodiments of the present invention, intrinsically retrochromic beads having different retroreflective colors may be combined to form a plurality of beads having a custom retroreflective color, if viewed at relatively low resolution where individual beads cannot be resolved. However, if a plurality of beads having such a custom retroreflective color is viewed at relatively higher magnification where individual beads can be resolved, it will appear as a mixture of beads having different retroreflective colors. Thus, an extra level of covert security may be imparted, as described above, if a plurality of beads having such a custom color is used for authentication of security documents.

Intrinsically retrochromic beads, alone or in kit form, are useful, for example, for preparing articles having a retrochromic pattern.

The following examples illustrate specific embodiments of the present invention. These examples are not intended to limit the present invention that is defined in the attached claims.

EXAMPLES

In the examples that follow, observed retroreflective color was determined by looking through a retroreflective viewer having the trade designation "3M VIEWER".

In the Examples and Tables that follow:

"mL" means milliliter;

"rt" means room temperature (that is, approximately 20 °C);

"min" means minute.

General Procedure for the Preparation of Type I Beads

The preparation of the silica-coated glass beads of Examples 1-182 were carried out using an apparatus similar to that shown in Figure 2. Eighty grams (g) of glass beads with an index of refraction of 1.9 and with an average diameter of 65 micrometers (available under the trade designation "FLEX-O-LITE 831 SIGN BEADS" from Flex-O-Lite, Inc., Chesterfield, MO,) were charged into a glass frit funnel type fluidized bed CVD reactor with a 30 millimeters (that is, mm) inner diameter reactor (as described, for example, in Example 1 of U.S. Pat. No. 5,673,148 (Morris et al.). For examples in which the reaction temperature was 50 °C or more, the reactor was wrapped with electric heating tape and monitored by the use of a thermocouple in the fluidized bed. For examples in which the reaction temperature was room temperature (that is, approximately 20 °C), no heating tape was used. The bed of beads was fluidized with a stream of nitrogen gas introduced into the reactor through the glass frit (that is, from the bottom of the bed of beads). Water vapor was simultaneously introduced into the reactor, through the glass frit, in a stream of nitrogen carrier gas by bubbling the carrier gas through water in a chamber separate from the reactor.

The metal oxide precursor compounds, either SiCl_4 (Examples 1-174), or a mixture of SiCl_4 and tetraethyl orthosilicate (TEOS, Examples 175-182), were introduced into the reactor, through a glass tube extending downward into the fluidized bed of beads, in a stream of nitrogen carrier gas by bubbling the carrier gas through the liquid precursor compound in a chamber separate from the reactor. For Examples 175-182, two separate chambers, one for each of the liquid precursor compounds, were used. Deposition of concentric coatings on the glass beads in Examples 1-182 commenced when the flow of reactant-laden nitrogen carrier gas through the reactor began.

Samples of concentrically coated glass beads were periodically removed from the reactor and were evaluated by viewing the samples in retroreflective mode. Thickness of the concentric coating was also determined by examining fractured concentrically coated glass beads with a scanning electron microscope.

Experimental details such as the flow rates of the reactant-laden carrier gases, the resultant thickness of the concentric coatings on the glass beads and the retroreflective color of the coated beads are reported in Tables 1 and 2 (below).

The preparation of the titania-coated glass beads of Examples 183-191 was carried out by the procedure used for Examples 1-182, except that a reactor having an 80 mm inner diameter was used and the titania precursor compound was TiCl_4 . Glass beads (1800 g) with an index of refraction of 1.9 and an average diameter of 65 micrometers (available under the trade designation "FLEX-O-LITE 831 SIGN BEADS", from Flex-O-Lite, Inc., Chesterfield, MO) were charged into the reactor. The reactor was wrapped with electric heating tape, which was used to maintain the temperature of the fluidized bed at approximately 175 °C as measured by a thermocouple in the fluidized bed. The flow rate of the nitrogen carrier gas through each of the separate reactant chambers was 7 liters per minute.

Samples of concentrically coated glass beads were periodically removed from the reactor and evaluated by viewing the samples in retroreflective mode with a retroviewer as above. Thickness of the deposited concentric coating (that is, optical interference layer) was also determined by examining fractured concentrically coated glass beads with a scanning electron microscope. Deposition times and the resultant retroreflective colors of the titania-coated glass beads, visually observed using a 3M VIEWER, are reported in Table 3 (below).

TABLE 1

Example No.	Reaction Temperature (°C)	SiCl_4 Flow Rate (mL/min)	H_2O Flow Rate (mL/min)	N_2 Flow Rate (mL/min)	Reaction Time (min)	Coating Thickness (nm)	Observed Retroreflective Color
1	rt	25	800	800	10	31.3	light gray
2	rt	25	800	800	20	62.6	light tan
3	rt	25	800	800	30	93.9	blue
4	rt	25	800	800	40	125.2	faint green-gray tint
5	50	42	475	150	4	7.4	white
6	50	42	475	150	5	9.2	white
7	50	42	475	150	6	11.0	white
8	50	42	475	150	7	12.9	very faint gray tint
9	50	42	475	150	8	14.7	very faint gray tint
10	50	42	475	150	9	16.6	very faint gray tint
11	50	42	475	150	10	18.4	very faint gray tint
12	50	42	475	150	11	20.2	very faint gray tint
13	50	42	475	150	12	22.1	very faint gray tint

Example No.	Reaction Temperature (°C)	SiCl ₄ Flow Rate (mL/min)	H ₂ O Flow Rate (mL/min)	N ₂ Flow Rate (mL/min)	Reaction Time (min)	Coating Thickness (nm)	Observed Retroreflective Color
14	50	42	475	150	13	23.9	very faint gray tint
15	50	42	475	150	14	25.8	very faint gray tint
16	50	42	475	150	15	27.6	very faint gray tint
17	50	42	475	150	16	29.4	light gray
18	50	42	475	150	17	31.3	light gray
19	50	42	475	150	18	33.1	light gray
20	50	42	475	150	19	35.0	light gray
21	50	42	475	150	20	36.8	light gray
22	50	42	475	150	21	38.6	light gray
23	50	42	475	150	22	40.5	light gray
24	50	42	475	150	23	42.3	light gray
25	50	42	475	150	24	44.2	light gray
26	50	42	475	150	25	46.0	light gray
27	50	42	475	150	26	47.8	very faint tan tint
28	50	42	475	150	27	49.7	very faint tan tint
29	50	42	475	150	28	51.5	very faint tan tint
30	50	42	475	150	29	53.4	faint tan tint
31	50	42	475	150	30	55.2	faint tan tint
32	50	42	475	150	31	57.0	light tan
33	50	42	475	150	32	58.9	light tan
34	50	42	475	150	33	60.7	light tan
35	50	42	475	150	34	62.6	light tan
36	50	42	475	150	35	64.4	light tan
37	50	42	475	150	36	66.2	light tan-faint red tint
38	50	42	475	150	37	68.1	faint red tint
39	50	42	475	150	38	69.9	faint red tint
40	50	42	475	150	39	71.8	light red
41	50	42	475	150	40	73.6	red-violet
42	50	42	475	150	41	75.4	violet-red
43	50	42	475	150	42	77.3	light violet-red
44	50	42	475	150	43	79.1	light violet
45	50	42	475	150	44	81.0	violet
46	50	42	475	150	45	82.8	violet
47	50	42	475	150	46	84.6	violet-blue
48	50	42	475	150	47	86.5	blue-violet
49	50	42	475	150	48	88.3	light blue-violet
50	50	42	475	150	49	90.2	light blue

Example No.	Reaction Temperature (°C)	SiCl ₄ Flow Rate (mL/min)	H ₂ O Flow Rate (mL/min)	N ₂ Flow Rate (mL/min)	Reaction Time (min)	Coating Thickness (nm)	Observed Retroreflective Color
51	50	42	475	150	50	92.0	blue
52	50	42	475	150	51	93.8	blue-green
53	50	42	475	150	52	95.7	light blue-green
54	50	42	475	150	53	97.5	light blue-green
55	50	42	475	150	54	99.4	light green-blue
56	50	42	475	150	55	101.2	light green-blue
57	50	42	475	150	56	103.0	light green-blue
58	50	42	475	150	57	104.9	light green-gray
59	50	42	475	150	58	106.7	light green-gray
60	50	42	475	150	59	108.6	light green-gray
61	50	42	475	150	60	110.4	faint green-gray tint
62	50	42	475	150	61	112.2	faint green-gray tint
63	50	42	475	150	62	114.1	faint green-gray tint
64	50	42	475	150	63	115.9	faint green-gray tint
65	50	42	475	150	64	117.8	faint green-gray tint
66	50	42	475	150	65	119.6	faint green-gray tint
67	50	42	475	150	66	121.4	faint green-gray tint
68	50	42	475	150	67	123.3	faint green-gray tint
69	50	42	475	150	68	125.1	faint green-gray tint
70	50	42	475	150	69	127.0	very faint gray tint
71	50	42	475	150	70	128.8	very faint gray tint
72	50	50	500	250	5	9.0	very faint gray tint
73	50	50	500	250	10	18.0	very faint gray tint
74	50	50	500	250	15	27.0	light gray
75	50	50	500	250	20	36.0	light gray
76	50	50	500	250	25	45.0	light gray
77	50	50	500	250	30	54.0	light tan
78	50	50	500	250	35	63.0	light tan-very faint red tint

Example No.	Reaction Temperature (°C)	SiCl ₄ Flow Rate (mL/min)	H ₂ O Flow Rate (mL/min)	N ₂ Flow Rate (mL/min)	Reaction Time (min)	Coating Thickness (nm)	Observed Retroreflective Color
79	50	50	500	250	40	72.0	light red
80	50	50	500	250	55	110.0	faint green-gray tint
81	50	50	500	250	60	120.0	faint green-gray tint
82	50	42	475	150	25	43.3	light gray
83	50	42	475	150	29	50.2	faint tan tint
84	50	42	475	150	33	57.1	light tan
85	50	42	475	150	35	60.6	light tan
86	50	42	475	150	37	64.0	light tan-very faint red tint
87	50	42	475	150	39	67.5	faint red tint
88	50	42	475	150	41	70.9	red-violet
89	50	42	475	150	43	74.4	violet-red
90	50	42	475	150	45	77.9	light violet
91	50	42	475	150	47	81.3	violet
92	50	42	475	150	49	84.8	violet-blue
93	50	42	475	150	51	88.2	light blue-violet
94	50	50	500	250	10	19.1	very faint gray tint
95	50	50	500	250	15	28.7	light gray
96	50	50	500	250	20	38.2	light gray
97	50	50	500	250	25	47.8	very faint tan tint
98	50	50	500	250	30	57.3	light tan
99	50	50	500	250	35	66.9	faint red tint
100	50	50	500	250	36	68.8	faint red tint
101	50	50	500	250	37	70.7	light red
102	50	50	500	250	38	72.6	red-violet
103	50	50	500	250	39.5	75.4	violet-red
104	50	50	500	250	10	18.4	very faint gray tint
105	50	50	500	250	15	27.6	very faint gray tint
106	50	50	500	250	20	36.8	light gray
107	50	50	500	250	25	46.0	light gray
108	50	50	500	250	27	49.7	very faint tan tint
109	50	50	500	250	29	53.4	faint tan tint
110	50	50	500	250	30	55.2	faint tan tint
111	50	50	500	250	31	57.0	light tan
112	50	50	500	250	32	58.9	light tan
113	50	50	500	250	33	60.7	light tan

Example No.	Reaction Temperature (°C)	SiCl ₄ Flow Rate (mL/min)	H ₂ O Flow Rate (mL/min)	N ₂ Flow Rate (mL/min)	Reaction Time (min)	Coating Thickness (nm)	Observed Retroreflective Color
114	50	50	500	250	34	62.6	light tan
115	50	50	500	250	35	64.4	light tan
116	50	50	500	250	10	19.1	very faint gray tint
117	50	50	500	250	15	28.7	light gray
118	50	50	500	250	20	38.2	light gray
119	50	50	500	250	25	47.8	very faint tan tint
120	50	50	500	250	26	49.7	very faint tan tint
121	50	50	500	250	27	51.6	very faint tan tint
122	50	50	500	250	28	53.5	faint tan tint
123	50	50	500	250	29	55.4	faint tan tint
124	rt	25	800	800	5	12.7	very faint gray tint
125	rt	25	800	800	10	25.3	very faint gray tint
126	rt	25	800	800	15	38.0	light gray
127	rt	25	800	800	20	50.6	very faint tan tint
128	rt	25	800	800	25	63.3	light tan-very faint red tint
129	rt	25	800	800	28	70.8	red-violet
130	rt	25	800	800	30	75.9	light violet-red
131	rt	25	800	800	32	81.0	violet
132	rt	25	800	800	33	83.5	violet-blue
133	rt	25	800	800	35	88.6	light blue-violet
134	rt	25	800	800	5	12.6	very faint gray tint
135	rt	25	800	800	10	25.2	very faint gray tint
136	rt	25	800	800	15	37.8	light gray
137	rt	25	800	800	20	50.4	very faint tan tint
138	rt	25	800	800	25	63.0	light tan-very faint red tint
139	rt	25	800	800	26	65.5	faint red tint
140	rt	25	800	800	27	68.0	faint red tint
141	rt	25	800	800	28	70.6	light red
142	rt	25	800	800	29	73.1	red-violet
143	rt	25	800	800	30	75.6	violet-red
144	rt	25	800	800	5	10.1	very faint gray tint
145	rt	25	800	800	10	20.2	very faint gray tint
146	rt	25	800	800	15	30.3	light gray
147	rt	25	800	800	20	40.4	light gray
148	rt	25	800	800	23	46.5	light gray
149	rt	25	800	800	25	50.5	very faint tan tint

Example No.	Reaction Temperature (°C)	SiCl ₄ Flow Rate (mL/min)	H ₂ O Flow Rate (mL/min)	N ₂ Flow Rate (mL/min)	Reaction Time (min)	Coating Thickness (nm)	Observed Retroreflective Color
150	rt	25	800	800	26	52.5	faint tan tint
151	rt	25	800	800	27	54.5	faint tan tint
152	rt	25	800	800	28	56.6	light tan
153	rt	25	800	800	29	58.6	light tan
154	rt	25	800	800	30	60.6	light tan
155	rt	25	800	800	31	62.6	light tan
156	rt	25	800	800	33	66.7	light tan-very faint red tint
157	rt	25	800	800	34	68.7	faint red tint
158	rt	25	800	800	35	70.7	faint red tint
159	rt	25	800	800	35.5	71.7	light red
160	rt	25	800	800	5	14.7	very faint gray tint
161	rt	25	800	800	10	29.3	light gray
162	rt	25	800	800	15	44.0	light gray
163	rt	25	800	800	18	52.7	faint tan tint
164	rt	25	800	800	20	58.6	light tan
165	rt	25	800	800	21	61.5	light tan
166	rt	25	800	800	22	64.5	light tan
167	rt	25	800	800	5	14.6	very faint gray tint
168	rt	25	800	800	10	29.1	light gray
169	rt	25	800	800	14	40.7	light gray
170	rt	25	800	800	15	43.7	very faint tan tint
171	rt	25	800	800	16	46.6	very faint tan tint
172	rt	25	800	800	17	49.5	very faint tan tint
173	rt	25	800	800	18	52.4	faint tan tint
174	rt	25	800	800	19	55.3	faint tan tint

TABLE 2

Example No.	Reaction Temperature (°C)	SiCl ₄ Flow Rate (mL/min)	TEOS Flow Rate (mL/min)	H ₂ O Flow Rate (mL/min)	Reaction Time (min)	Coating Thickness (nm)	Observed Retroreflective Color
175	50	50	250	500	10	21.1	very faint gray tint
176	50	50	250	500	15	31.7	light gray
177	50	50	250	500	20	42.2	light gray
178	50	50	250	500	25	52.8	faint tan tint
179	50	50	250	500	30	63.3	light tan-faint red tint
180	50	50	250	500	31	65.4	faint red tint

Example No.	Reaction Temperature (°C)	SiCl ₄ Flow Rate (mL/min)	TEOS Flow Rate (mL/min)	H ₂ O Flow Rate (mL/min)	Reaction Time (min)	Coating Thickness (nm)	Observed Retroreflective Color
181	50	50	250	500	33	69.6	faint red tint
182	50	50	250	500	34	71.7	light red

TABLE 3

Example No.	Coating Time (min)	Observed Retroreflective Color
183	20	pale silver/blue
184	40	pale gold/gray
185	60	rust/violet
186	67	blue/violet
187	74	blue
188	80	blue-green
189	88	green
190	94	yellow-green
191	133	blue-green

General Procedure for the Preparation of Type II Beads

Retrochromic beads having microcrystalline regions therein were prepared by combining in a porcelain milling jar with 1600 g of 1-cm zirconium oxide milling media (obtained under the trade designation "3/8 INCH (0.95 CM) RADIUS END ZIRCONIA CYLINDERS," item no. MEDZOC.37, from Paul O. Abbe, Inc., Little Falls, NJ); water; zirconium oxide (obtained under the trade designation "CF-PLUS-HM" from Z-TECH division of Carpenter Engineering Products, Bow, NH); aluminum oxide (obtained under the trade designation "16SG" from ALCOA Industrial Chemicals, Pittsburgh, PA); titanium oxide (obtained under the trade designation "KRONOS 1000" from KRONOS, Cranbury, NJ); wollastonite (obtained under the trade designation "VANSIL W-30" from R.T. Vanderbilt, Norwalk, CT); talc (obtained under the trade designation "SUPRAFINO H" from Luzenac America, Englewood, CO); and either cobalt(II) nitrate hexahydrate (obtained under the trade designation "COBALT NITRATE CRYSTALS, Lot KMDJ" from Mallinckrodt, Paris, KY) and carboxymethylcellulose (Preparative Examples 1-2, obtained under the trade designation "CMC 7L2C" from Aqualon Division of Hercules

Incorporated, Hopewell, VA), or iron(III) nitrate nonahydrate (Preparative Examples 3-4, obtained under the trade designation "I110-500" from Fisher, Fairlawn, NJ). After the respective mixtures were milled for 3 hours, each was dried to yield a powder cake, which was then ground with a mortar and pestle.

The ground powder was fed into the flame of a hydrogen/oxygen torch obtained from Bethlehem Apparatus Company, Hellertown, PA, under the trade designation "BETHLEHEM BENCH BURNER PM2D MODEL B", hereinafter referred to as "Bethlehem Burner". The Bethlehem Burner delivered hydrogen and oxygen in the inner ring at 8.0 and 3.0 standard liters per minute, respectively, and in the outer ring at 23.0 and 9.8 standard liters per minute, respectively. The melted particles were entrained in the flame and projected into a water bath where they were rapidly cooled (that is, quenched). The quenched beads were passed through the flame a second time and quenched again to improve their optical quality.

The quenched glass beads were devitrified by placing them in alumina crucibles and subjecting them to heat treatments in a furnace by ramping the temperature up from room temperature to the desired temperature at a rate of 10 °C per minute, maintaining the desired temperature for the desired "hold" time and then allowing the furnace to cool slowly to room temperature. The beads were removed from the crucibles after they were cooled to room temperature. The weights of reactants, the hold temperatures and hold times and the ambient-light and retroreflective colors of the beads of Preparative Examples 1-4 are reported in Table 4 (below). The resultant Type II intrinsically retrochromic are useful for preparing articles according to the present invention.

TABLE 4

Component	Preparative Example 1	Preparative Example 2	Preparative Example 3	Preparative Example 4
water	160 g	160 g	350 g	350 g
ZrO ₂	29.12 g	29.12 g	29.12 g	29.12 g
Al ₂ O ₃	51.31 g	51.31 g	51.31 g	51.31 g
TiO ₂	62.37 g	62.37 g	62.37 g	62.37 g
talc	10.50 g	10.50 g	35.71 g	35.71 g

Component	Preparative Example 1	Preparative Example 2	Preparative Example 3	Preparative Example 4
wollastonite	48.24 g	48.24 g	24.12 g	24.12 g
Co(NO ₃) ₂ ·6H ₂ O	7.25 g	7.25 g	none	none
Fe(NO ₃) ₃ ·9H ₂ O	none	none	5.06 g	5.06 g
carboxymethylcellulose	3.0 g	3.0 g	none	none
hold temperature	940 °C	985 °C	975 °C	1000 °C
hold time	30 min	30 min	30 min	60 min
color in ambient light	gray-blue	gray-blue	off-white	off-white
retroreflective color	silver-blue	brown	yellow	orange-brown

EXAMPLE 192

A kit of intrinsically retrochromic beads was prepared as follows. Intrinsically retrochromic beads (approximately 1 g each), prepared according to Examples 37-49 were dispensed separately into thirteen 2 mL (0.5 dram) glass vials with caps (available under the trade designation "CLASS A CLEAR GLASS THREADED VIALS WITH RUBBER-LINED CLOSURES" from Fisher Scientific, Pittsburgh, PA). The vials were placed into slots of a cardboard container (available under the trade designation "WHEATON LAB FILE STORAGE SYSTEM" from Fisher Scientific).

EXAMPLE 193

A kit of intrinsically retrochromic beads was prepared as follows. Intrinsically retrochromic beads (approximately 1 g each), prepared according to Examples 37-49 were dispensed separately into thirteen 2 mL (0.5 dram) glass vials with caps (obtained from Fisher Scientific, Pittsburgh, PA, under the trade designation "CLASS A CLEAR GLASS THREADED VIALS WITH RUBBER-LINED CLOSURES"). The vials were affixed to cardboard (commercially available under the trade designation "REGULAR MAT BOARD CR-SRM 989 RAVEN BLACK", from Crescent Cardboard Co. LLC, Wheeling, IL) using transparent tape (obtained from the 3M Company under the trade designation name "SCOTCH BRAND TRANSPARENT TAPE 600").

What is claimed is:

1. A method of making intrinsically retrochromic beads comprising:
providing a fluidized bed of beads;
depositing a concentric optical interference layer onto the respective surface of each of a plurality of beads to form a plurality of coated beads; and
removing a first portion of coated beads from the fluidized bed,
wherein the concentric optical interference layers comprising the first portion have a first average thickness, and wherein the first portion comprises intrinsically retrochromic beads.
2. The method of claim 1, wherein at least one of the coated beads has a first refractive index, wherein the concentric optical interference layer of said at least one bead has a second refractive index, and wherein the second refractive index is greater than the first refractive index.
3. The method of claim 1, wherein at least one of the coated beads has a first refractive index, wherein the concentric optical interference layer of said at least one bead has a second refractive index, and wherein the second refractive index is less than the first refractive index.
4. The method of claim 1, further comprising removing a second portion of coated beads from the fluidized bed, wherein the concentric optical interference layers comprising the second portion have a second average thickness, and wherein the second portion comprises intrinsically retrochromic beads, wherein the second average thickness is greater than the first average thickness.
5. The method of claim 1 or 4, wherein the concentric optical interference layer comprises a metal oxide.
6. The method of claim 5, wherein the metal oxide comprises at least one of silica, titania, or alumina.

7. The method of claim 1 or 4, wherein depositing comprises chemical vapor deposition.
8. The method of claim 7, wherein depositing further comprises hydrolysis.
9. The method of claim 4, wherein the first and second portions have different retroreflective colors.
10. The method of claim 1 or 4, wherein the beads comprise a colorant.
11. The method of claim 4, further comprising removing a third portion of coated beads from the fluidized bed, wherein the concentric optical interference layers comprising the third portion have a third average thickness, and wherein the third portion comprises intrinsically retrochromic beads, wherein the third average thickness is greater than the second average thickness.
12. The method of claim 1, 4, or 11, further comprising the step of monitoring the deposition of the concentric optical interference layer by viewing the coated beads in retroreflective mode.
13. The method of claim 11, wherein the first, second, and third portions have different retroreflective colors.
14. The method of claim 11, wherein the different retroreflective colors comprise a retroreflective color palette.
15. A kit comprising a first plurality of intrinsically retrochromic beads having a first average retroreflective color, a second plurality of intrinsically retrochromic beads having a second average retroreflective color, and a third plurality of intrinsically retrochromic beads having a third average retroreflective color, wherein said retroreflective colors are distinct and comprise a retroreflective color palette.

16. The kit of claim 15, wherein the first, second, and third pluralities of intrinsically retrochromic beads are separately confined within at least one reclosable container.
17. The kit of claim 15, wherein the pluralities of intrinsically retrochromic beads are confined within respective reclosable containers.
18. The kit of claim 17, wherein the holder is adapted to receive said reclosable containers.
19. The kit of claim 15, wherein the retroreflective color palette comprises at least three of violet, blue, orange, yellow, red, or green retroreflective colors, if viewed using white light illumination.
20. The kit of claim 15, wherein the retroreflective color palette comprises yellow, magenta, and cyan retroreflective colors, if viewed using white light illumination.
21. The kit of claim 15, wherein said pluralities have substantially the same average color if viewed in nonretroreflective mode.
22. The kit of claim 15, wherein at least one of the intrinsically retrochromic beads comprises a core and a concentric optical interference layer.
23. The kit of claim 22, wherein the index of refraction of the concentric optical interference layer is less than the index of refraction of the core.
24. The kit of claim 22, wherein the index of refraction of the concentric optical interference layer is greater than the index of refraction of the core.
25. The kit of claim 22, wherein at least one of the intrinsically retrochromic beads has microcrystalline regions.

26. The kit of claim 22, further comprising a fourth plurality of retroreflective beads wherein said fourth plurality is distinct from said first, second, and third pluralities and wherein said fourth plurality is not intrinsically retrochromic.
27. The kit of claim 22, wherein the retroreflective color palette comprises at least three of violet, blue, orange, yellow, red, or green retroreflective colors if viewed using white light illumination.
28. The kit of claim 22, wherein the palette comprises yellow, magenta, and cyan retroreflective colors, if viewed using white light illumination.
29. The kit of claim 22, wherein said pluralities have substantially the same average color if viewed in nonretroreflective mode.
30. A method of preparing a plurality of retroreflective beads having a custom retroreflective color comprising:
 providing a first plurality of intrinsically retrochromic beads having a first average retroreflective color;
 providing a second plurality of intrinsically retrochromic beads having a second average retroreflective color; and
 combining, with mixing, said first and second pluralities of retrochromic beads.
31. The method of claim 30, further comprising:
 providing a third plurality of intrinsically retrochromic beads having a third retroreflective color; and
 combining, with mixing, the third plurality of intrinsically retrochromic beads with said first and second pluralities of retrochromic beads.

1/1

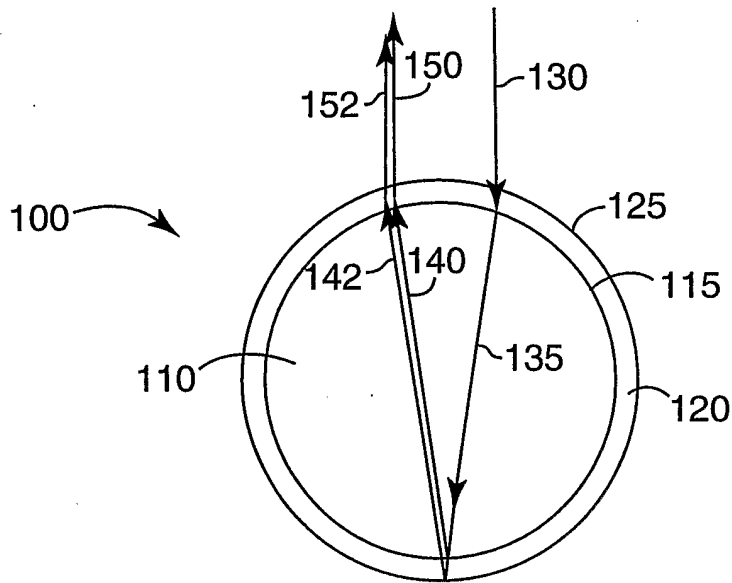

FIG. 1

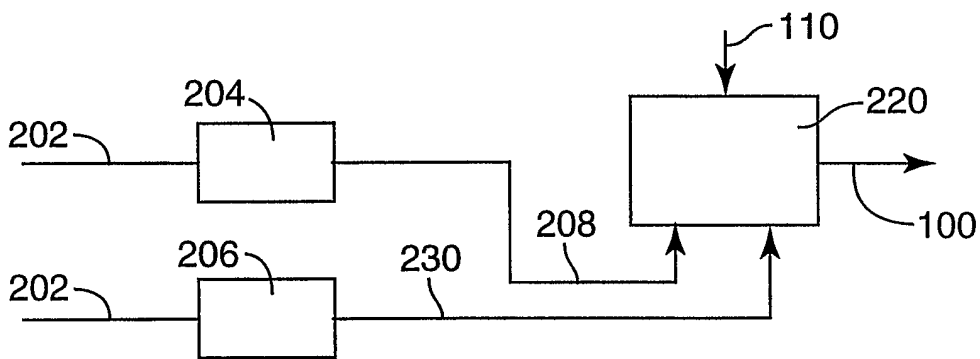

FIG. 2

INTERNATIONAL SEARCH REPORT

International Application No

PCT/US 03/03907

A. CLASSIFICATION OF SUBJECT MATTER

IPC 7 G02B5/128

According to International Patent Classification (IPC) or to both national classification and IPC

B. FIELDS SEARCHED

Minimum documentation searched (classification system followed by classification symbols)

IPC 7 G02B

Documentation searched other than minimum documentation to the extent that such documents are included in the fields searched

Electronic data base consulted during the international search (name of data base and, where practical, search terms used)

EPO-Internal

C. DOCUMENTS CONSIDERED TO BE RELEVANT

Category °	Citation of document, with indication, where appropriate, of the relevant passages	Relevant to claim No.
X	US 5 673 148 A (MORRIS GEOFFREY P ET AL) 30 September 1997 (1997-09-30) cited in the application abstract column 4, line 3 - line 14 column 6, line 34 - line 40 column 7, line 20 - line 29 figures	1-31
A	US 6 000 804 A (KIMURA ASA) 14 December 1999 (1999-12-14) abstract column 2, line 37 - line 43 column 6, line 13 - line 43 column 7, line 58 - line 67 column 8, line 1 - line 10 figure 6	1-30



Further documents are listed in the continuation of box C.



Patent family members are listed in annex.

° Special categories of cited documents :

- *A* document defining the general state of the art which is not considered to be of particular relevance
- *E* earlier document but published on or after the international filing date
- *L* document which may throw doubts on priority claim(s) or which is cited to establish the publication date of another citation or other special reason (as specified)
- *O* document referring to an oral disclosure, use, exhibition or other means
- *P* document published prior to the international filing date but later than the priority date claimed

- *T* later document published after the international filing date or priority date and not in conflict with the application but cited to understand the principle or theory underlying the invention
- *X* document of particular relevance; the claimed invention cannot be considered novel or cannot be considered to involve an inventive step when the document is taken alone
- *Y* document of particular relevance; the claimed invention cannot be considered to involve an inventive step when the document is combined with one or more other such documents, such combination being obvious to a person skilled in the art.
- *&* document member of the same patent family

Date of the actual completion of the international search

4 July 2003

Date of mailing of the international search report

16/07/2003

Name and mailing address of the ISA

European Patent Office, P.B. 5818 Patentlaan 2
NL - 2280 HV Rijswijk
Tel. (+31-70) 340-2040, Tx. 31 651 epo nl,
Fax: (+31-70) 340-3016

Authorized officer

Seibert, J

INTERNATIONAL SEARCH REPORT

International Application No

PCT/US 03/03907

C.(Continuation) DOCUMENTS CONSIDERED TO BE RELEVANT

Category *	Citation of document, with indication, where appropriate, of the relevant passages	Relevant to claim No.
A	GB 1 415 792 A (EIGENMANN LUDWIG) 26 November 1975 (1975-11-26) page 4, line 8 - line 20 figure 5 ---	1-30
A	EP 0 819 953 A (MINNESOTA MINING & MFG) 21 January 1998 (1998-01-21) abstract; figure 10 ---	1-30
A	US 3 700 305 A (BINGHAM WALLACE KARL) 24 October 1972 (1972-10-24) abstract; figures ---	1-30
A	US 2 713 286 A (TAYLOR NELSON W) 19 July 1955 (1955-07-19) figure 2 -----	1-30

INTERNATIONAL SEARCH REPORT

International Application No

PCT/US 03/03907

Patent document cited in search report		Publication date	Patent family member(s)	Publication date
US 5673148	A	30-09-1997	AU 2373995 A	19-01-1996
			CA 2190956 A1	04-01-1996
			CN 1164897 A	12-11-1997
			EP 0766837 A1	09-04-1997
			JP 10503291 T	24-03-1998
			WO 9600404 A1	04-01-1996
US 6000804	A	14-12-1999	BR 9803814 A	07-12-1999
			EP 0905530 A2	31-03-1999
			JP 11167010 A	22-06-1999
			TW 417023 B	01-01-2001
			JP 2000081831 A	21-03-2000
			JP 2000081832 A	21-03-2000
GB 1415792	A	26-11-1975	IT 946620 B	21-05-1973
			IT 1003066 B	10-06-1976
			AT 331679 B	25-08-1976
			AT 28673 A	15-11-1975
			BE 794047 A1	02-05-1973
			CA 998301 A1	12-10-1976
			CH 566876 A5	30-09-1975
			DE 2302170 A1	06-09-1973
			DK 137077 B	16-01-1978
			FR 2168358 A1	31-08-1973
			JP 48080291 A	27-10-1973
			NL 7300593 A	17-07-1973
			SE 381863 B	22-12-1975
			AR 198299 A1	14-06-1974
			AU 5762673 A	09-01-1975
			CS 178131 B2	31-08-1977
			DD 106919 A5	05-07-1974
IL 41920 A	30-09-1976			
US 3874784 A	01-04-1975			
EP 0819953	A	21-01-1998	EP 0819953 A2	21-01-1998
			AU 703068 B2	11-03-1999
			AU 4463296 A	19-06-1996
			BR 9509836 A	21-10-1997
			CA 2206319 A1	06-06-1996
			DE 69504370 D1	01-10-1998
			DE 69504370 T2	12-05-1999
			EP 0795137 A2	17-09-1997
			JP 10510227 T	06-10-1998
			WO 9617263 A2	06-06-1996
			US 6060157 A	09-05-2000
US 3700305	A	24-10-1972	AR 211758 A1	15-03-1978
			AT 327750 B	10-02-1976
			AT 1064771 A	15-04-1975
			AU 458362 B2	27-02-1975
			AU 3605671 A	31-05-1973
			CA 946805 A1	07-05-1974
			DE 2160907 A1	29-06-1972
			DK 128197 B	18-03-1974
			ES 397418 A1	16-05-1975
			FR 2117893 A5	28-07-1972
			GB 1350649 A	18-04-1974
			IT 945114 B	10-05-1973

INTERNATIONAL SEARCH REPORT

International Application No

PCT/US 03/03907

Patent document cited in search report		Publication date	Patent family member(s)	Publication date
US 3700305	A		JP 54018119 B NL 7116535 A ,B SE 378915 B ZA 7107807 A	05-07-1979 16-06-1972 15-09-1975 30-08-1972
US 2713286	A	19-07-1955	DE 865105 C FR 1027009 A GB 716864 A	29-01-1953 06-05-1953 13-10-1954