

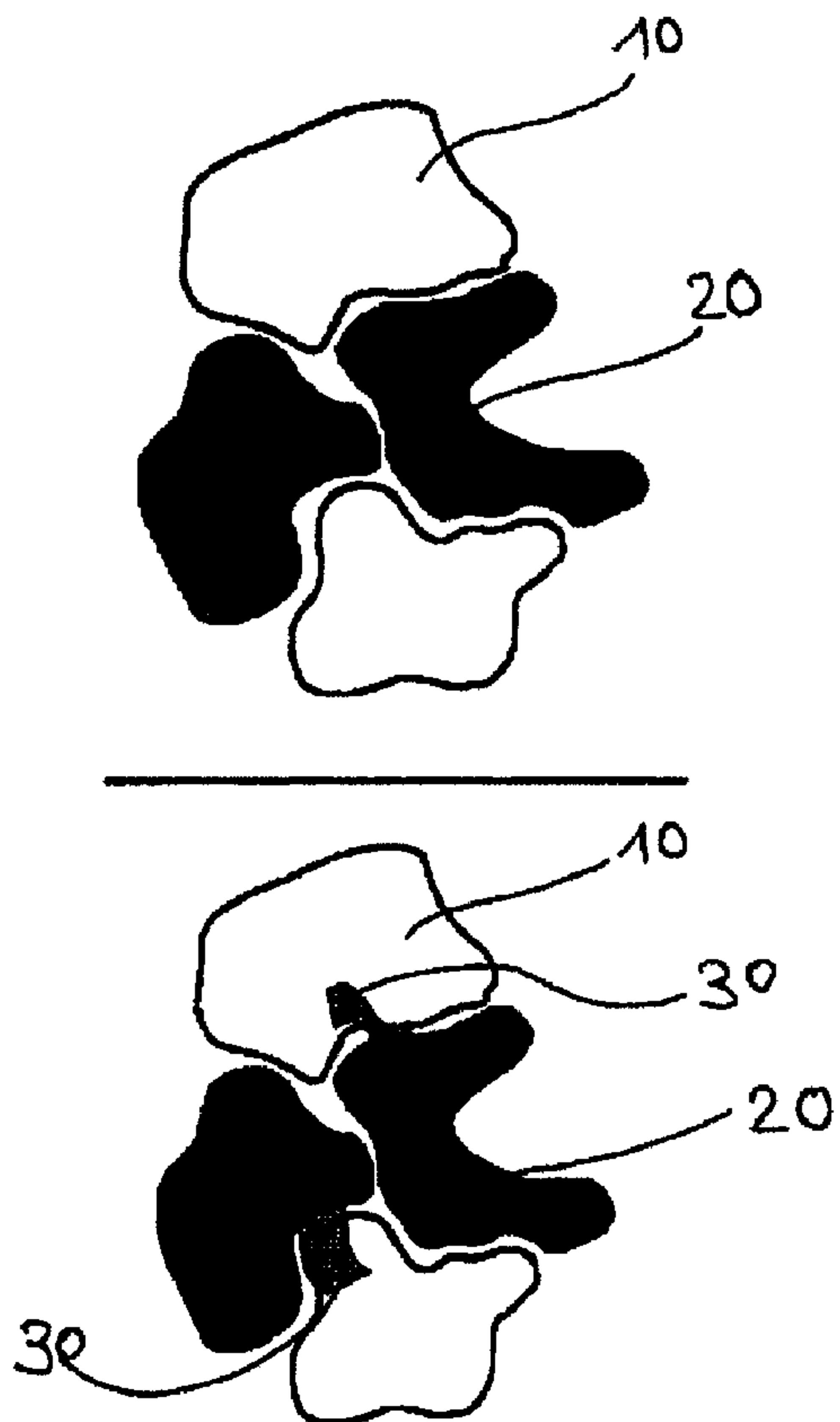

(86) Date de dépôt PCT/PCT Filing Date: 2009/07/11  
 (87) Date publication PCT/PCT Publication Date: 2010/01/21  
 (45) Date de délivrance/Issue Date: 2013/02/19  
 (85) Entrée phase nationale/National Entry: 2011/01/14  
 (86) N° demande PCT/PCT Application No.: EP 2009/005052  
 (87) N° publication PCT/PCT Publication No.: 2010/006744  
 (30) Priorité/Priority: 2008/07/15 (DE10 2008 034 015.4)

(51) Cl.Int./Int.Cl. *B43K 19/02* (2006.01),  
*B43K 19/16* (2006.01)  
 (72) Inventeurs/Inventors:  
 THIES, ANDREAS, DE;  
 LINS, NIKOLAS, DE;  
 DELAPIERRE-KOHL, CHRISTINE, DE;  
 HERBOLSHEIMER, JOHANNES, DE;  
 JAKOB, MARTIN, DE;  
 LANG, HARALD, DE;  
 ARTHEN, SIMONE, DE  
 (73) Propriétaire/Owner:  
 J.S. STAEDTLER GMBH & CO. KG, DE  
 (74) Agent: RIDOUT & MAYBEE LLP

(54) Titre : CRAYON POUR ECRIRE, DESSINER, COLORIER OU DE MAQUILLAGE  
 (54) Title: WRITING, DRAWING, DECORATING OR COSMETIC PENCIL



(57) Abrégé/Abstract:

The invention relates to a writing, drawing, decorating or cosmetic pencil comprising a colour-delivering, polymer-bonded lead and a polymerbonded wood substitute material, the wood substitute material at least partly covering or surrounding the lead along its

(57) **Abrégé(suite)/Abstract(continued):**

length, there being disposed, between the lead and the wood substitute material, at least one adhesion promoter layer, the lead and the wood substitute material each comprising at least one polymer, the at least one polymer in the lead being incompatible with the at least one further polymer in the wood substitute material, and the at least one adhesion promoter layer coupling on the one hand to the at least one polymer in the lead and on the other hand to the at least one further polymer in the wood substitute material.

## (12) NACH DEM VERTRAG ÜBER DIE INTERNATIONALE ZUSAMMENARBEIT AUF DEM GEBIET DES PATENTWESENS (PCT) VERÖFFENTLICHTE INTERNATIONALE ANMELDUNG

(19) Weltorganisation für geistiges Eigentum  
Internationales Büro(43) Internationales Veröffentlichungsdatum  
21. Januar 2010 (21.01.2010)(10) Internationale Veröffentlichungsnummer  
**WO 2010/006744 A1**

## (51) Internationale Patentklassifikation:

*B43K 19/02* (2006.01) *B43K 19/16* (2006.01)

(21) Internationales Aktenzeichen: PCT/EP2009/005052

(22) Internationales Anmeldedatum:

11. Juli 2009 (11.07.2009)

(25) Einreichungssprache: Deutsch

(26) Veröffentlichungssprache: Deutsch

(30) Angaben zur Priorität:

10 2008 034 015.4 15. Juli 2008 (15.07.2008) DE

(71) Anmelder (für alle Bestimmungsstaaten mit Ausnahme von US): **J.S. STAEDTLER GMBH & CO. KG** [DE/DE]; Moosackerstrasse 3, 90427 Nürnberg (DE).

(72) Erfinder; und

(75) Erfinder/Anmelder (nur für US): **THIES, Andreas** [DE/DE]; Hofgärten 16b, 91090 Effeltrich (DE). **LINS, Nikolas** [DE/DE]; Marienbader Strasse 2, 90571 Schwaig Behringersdorf (DE). **DELAPIERRE-KOHL, Christine**[DE/DE]; Am Stockberg 25, 91074 Herzogenaurach (DE). **HERBOLSHEIMER, Johannes** [DE/DE]; Egenhausen 28, 91619 Oberzenn (DE). **JAKOB, Martin** [DE/DE]; Schlossgarten 23, 90768 Fürth (DE). **LANG, Harald** [DE/DE]; Hauptstrasse 10, 91484 Sugenheim (DE). **ARTHEN, Simone** [DE/DE]; Schwabacherstrasse 90/92, 90439 Nürnberg (DE).(81) **Bestimmungsstaaten** (soweit nicht anders angegeben, für jede verfügbare nationale Schutzrechtsart): AE, AG, AL, AM, AO, AT, AU, AZ, BA, BB, BG, BH, BR, BW, BY, BZ, CA, CH, CL, CN, CO, CR, CU, CZ, DK, DM, DO, DZ, EC, EE, EG, ES, FI, GB, GD, GE, GH, GM, GT, HN, HR, HU, ID, IL, IN, IS, JP, KE, KG, KM, KN, KP, KR, KZ, LA, LC, LK, LR, LS, LT, LU, LY, MA, MD, ME, MG, MK, MN, MW, MX, MY, MZ, NA, NG, NI, NO, NZ, OM, PE, PG, PH, PL, PT, RO, RS, RU, SC, SD, SE, SG, SK, SL, SM, ST, SV, SY, TJ, TM, TN, TR, TT, TZ, UA, UG, US, UZ, VC, VN, ZA, ZM, ZW.(84) **Bestimmungsstaaten** (soweit nicht anders angegeben, für jede verfügbare regionale Schutzrechtsart): ARIPO (BW,

[Fortsetzung auf der nächsten Seite]

(54) Title: WRITING, DRAWING, DECORATING OR COSMETIC PENCIL

(54) Bezeichnung: SCHREIB-, ZEICHEN-, MAL- ODER KOSMETIKSTIFT

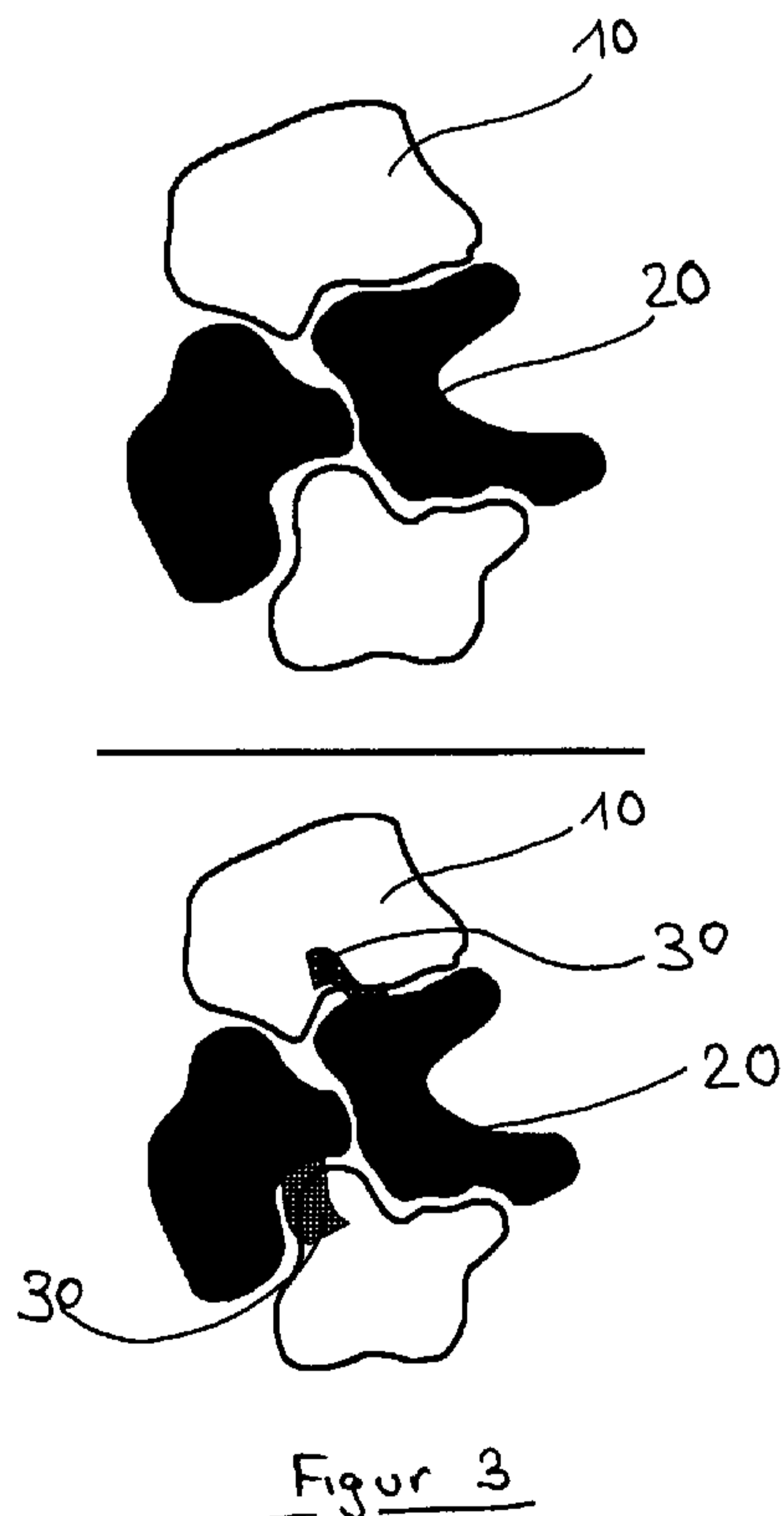
(57) **Abstract:** The invention relates to a writing, drawing, decorating or cosmetic pencil comprising a colour-delivering, polymer-bonded lead and a polymer-bonded wood substitute material, the wood substitute material at least partly covering or surrounding the lead along its length, there being disposed, between the lead and the wood substitute material, at least one adhesion promoter layer, the lead and the wood substitute material each comprising at least one polymer, the at least one polymer in the lead being incompatible with the at least one further polymer in the wood substitute material, and the at least one adhesion promoter layer coupling on the one hand to the at least one polymer in the lead and on the other hand to the at least one further polymer in the wood substitute material.(57) **Zusammenfassung:** Die Erfindung betrifft einen Schreib-, Zeichen-, Mal- oder Kosmetikstift, umfassend eine farbgebende polymergebundene Mine und einen polymergebundenen Holzersatzwerkstoff, wobei der Holzersatzwerkstoff die Mine der Länge nach zumindest teilweise bedeckt oder umgibt, und wobei zwischen der Mine und dem Holzersatzwerkstoff mindestens eine Haftvermittlerschicht angeordnet ist, wobei die Mine und der Holzersatzwerkstoff jeweils mindestens ein Polymer aufweisen, wobei das mindestens ein Polymer in der Mine zu dem mindestens einen weiteren Polymer im Holzersatzwerkstoff inkompatibel ist, und wobei die mindestens eine Haftvermittlerschicht einerseits an das mindestens ein Polymer in der Mine und andererseits an das mindestens ein weiteres Polymer im Holzersatzwerkstoff ankoppelt.

**WO 2010/006744 A1** 

---

GH, GM, KE, LS, MW, MZ, NA, SD, SL, SZ, TZ, UG, ZM, ZW), eurasisches (AM, AZ, BY, KG, KZ, MD, RU, TJ, TM), europäisches (AT, BE, BG, CH, CY, CZ, DE, DK, EE, ES, FI, FR, GB, GR, HR, HU, IE, IS, IT, LT, LU, LV, MC, MK, MT, NL, NO, PL, PT, RO, SE, SI, SK, SM, TR), OAPI (BF, BJ, CF, CG, CI, CM, GA, GN, GQ, GW, ML, MR, NE, SN, TD, TG).

**Veröffentlicht:**

- *mit internationalem Recherchenbericht (Artikel 21 Absatz 3)*
- *vor Ablauf der für Änderungen der Ansprüche geltenden Frist; Veröffentlichung wird wiederholt, falls Änderungen eingehen (Regel 48 Absatz 2 Buchstabe h)*

**Erklärungen gemäß Regel 4.17:**

- *Erfindererklärung (Regel 4.17 Ziffer iv)*

WRITING, DRAWING, DECORATING OR COSMETIC PENCIL

The invention relates to a writing, drawing, decorating or cosmetic pencil comprising a colour-delivering, polymer-bonded lead and a polymer-bonded wood substitute material, the wood substitute material at least partly covering or surrounding the lead along its length, there being disposed between the lead and the wood substitute material at least one adhesion promoter layer. The invention further relates to a method of producing a writing, drawing, decorating or cosmetic pencil of this type.

Pencils of the type mentioned above are known in principle. In this case, the wood substitute material replaces the naturally grown wood typically used to hold the colour-delivering lead.

Wood-mounted pencils in which the lead is surrounded or encased in natural wood have been known for some time. In recent years, the price of high-grade woods has risen due to their short supply and this has had a direct impact on the production cost of the pencils. In addition, comparatively large natural wood reserves are used in the production of pencils.

For this reason, people have strived for years to replace natural wood with wood substitute materials, which are more cost-effective and conserve natural wood stocks.

Hence, DE 42 30 792 C2 has already disclosed co-extruded pencils with a polymer-bonded lead and a shaft made from a wood substitute material in the form of an expanded polymer to encase the lead rather than wood. The disadvantage of such pencils, however, is that this sort of wood substitute material has a low modulus of

- 2 -

elasticity and therefore a high elasticity, which the lead itself does not normally possess. The result is that the lead may break or be damaged in the pencil. In order to circumvent this problem, the lead is usually  
5 adjusted to the same elasticity, which in turn results in a significant deterioration in its writing properties.

10 It is furthermore to be seen as detrimental that a pencil with a wood substitute material made from an expanded polymer has a sharpening performance unlike that of naturally grown wood for the user. The customary sharpening noise and brittleness inherent in naturally grown wood are missing.

15 Furthermore, co-extruded pencils with polymer-bonded leads and polymer-bonded wood substitute material are known, wherein the wood substitute material has inorganic fillers. It must be seen as a disadvantage  
20 that the sharpenability of these pencils has to be classed as inadequate, on account of the inorganic fillers.

The object of the invention is therefore to create a  
25 writing, drawing, decorating or cosmetic pencil with a sharpening performance resembling that of a wood-mounted pencil and, in addition, with a lead having excellent writing properties and also to provide a method of producing such a pencil.

30 The object for the writing, drawing, decorating or cosmetic pencil, comprising a colour-delivering, polymer-bonded lead and a polymer-bonded wood substitute material, the wood substitute material at  
35 least partly covering or surrounding the lead along its length, there being disposed between the lead and the wood substitute material at least one adhesion promoter

- 3 -

layer, is achieved in that the lead and the wood substitute material each comprises at least one polymer, the at least one polymer in the lead being incompatible with the at least one further polymer in the wood substitute material, and in that the at least one adhesion promoter layer is connected, on the one hand, to the at least one polymer in the lead and, on the other hand, to the at least one further polymer in the wood substitute material.

10

It has emerged that in order for the intended object to be achieved, the lead and the wood substitute material must be formed on the basis of different polymer bonds, so that, on the one hand, the necessary writing properties of the lead and, on the other, the necessary rigidity and sharpenability of the wood substitute material can be achieved. It has further emerged that this requires the lead and the wood substitute material to contain polymers that are incompatible with one another. This means that the lead material and the wood substitute material make no connection with one another or only an insufficiently firm connection. As a result, the lead is not sufficiently supported during use and frequently breaks during writing. For this reason, efforts are made to dispose at least one adhesion promoter layer between the lead and the wood substitute material. Surprisingly, it has emerged that at least one adhesion promoter layer, which, on the one hand, is connected to the at least one polymer in the lead and, on the other hand, to the at least one further polymer in the wood substitute material, creates a firm, permanent connection between the lead and the wood substitute material. A pencil produced in this way has the necessary properties in relation to the sharpenability and writing properties of the lead and could be mistaken for a wood-mounted pencil.

35

- 4 -

In order to assess the sharpenability of pencils according to the invention, these were sharpened. In this case, a pencil with a so-called sharpening moment of less than 10 Ncm during testing or sharpening is regarded as sharpenable with little effort. The sharpening moment is determined in a piece of test equipment intended for this purpose, by continuously sharpening a test specimen in the form of a pencil for 20 secs. The average torque [in Ncm] determined during sharpening, which is necessary for the continuous sharpening of a pencil with a diameter of  $7.6 \pm 0.2$  mm at a speed of 43 rpm which already has a pointed end, i.e. is already sharpened to the desired angle, in a customary sharpener with a new blade, is referred to as the sharpening moment.

The principle of a device for measuring the sharpening moment is illustrated for clarification in Figure 1. This involves a pencil sharpener 1 being secured in a clamp 3 connected to a torque measuring device 2. A pencil 5 is rotatably supplied in an adapter 4 and introduced into the sharpener 1. The rotating pencil 5 is fed forward pneumatically in the direction of the sharpener 1 by means of a feed mechanism 6, which acts on the adapter 4 holding the pencil 5 with a feed force of 20 N (see arrow to the right of the picture). The torque measured during the sharpening procedure of the pencil 5 by the torque measuring device 2 is recorded and averaged out over the test duration, in order to determine the sharpening moment.

The desired flexural strength of the wood substitute material for use as a casing for lead in pencils is particularly around at least 50 MPa. The modulus of elasticity is preferably around at least 5000 MPa. The flexural strength and modulus of elasticity are

- 5 -

determined using the 3-point flexural test according to DIN 52186 (Wood Testing - Flexural Test).

Figure 2 shows a measuring device for carrying out this sort of 3-point flexural test. Cylindrical test specimens 7 in the form of pencils with a diameter of  $7.6 \pm 0.2$  mm and a length of  $180 \pm 5$  mm are used. The test specimen 7 is mounted on moving rollers 8 with a width between supports of 100 mm (gap between the mid-points of the rollers 8). Force is applied to the centre using a test stamp 9. The rollers 8 and test stamp 9 have a 15 mm radius. The test specimen 7 is evenly loaded during testing, until the test specimen 7 breaks. The flexural strength and modulus of elasticity of the test specimen 7 are determined from the necessary breaking force and the measured deflection of the test specimen 7 under the increasing load.

Examples of writing, drawing or decorating pencils are particularly lead or coloured pencils. Examples of cosmetic pencils are particularly kohl pencils or lip liners.

Advantageous embodiments of the pencil according to the invention are listed below.

It has proved particularly beneficial for the at least one polymer in the lead to be made from polystyrene or SAN.

It has further proved beneficial if the at least one other polymer in the wood substitute material is chosen from the group of polyolefins.

Polyolefins in the wood substitute material are incompatible with polystyrene or SAN in the lead.

- 6 -

The at least one adhesion promoter layer is preferably formed from a copolymer, a block polymer, a graft polymer or a polymer blend.

5 It is particularly preferable for the at least one adhesion promoter layer to be formed from a styrene-butadiene copolymer and/or a styrene/ethene-butene/styrene block copolymer, in order to connect a polyolefin in the wood substitute material to  
10 polystyrene or SAN in the lead.

The mode of operation of the adhesion promoter is explained in greater detail with the help of the following figures.

15

Figure 3 above shows incompatible polymers 10 and 20, which exist together at their boundary surfaces without any connection. By contrast, Figure 3 below shows a bridging between the domains of the inherently  
20 incompatible polymers 10 and 20 in the presence of an adhesion promoter 30. The adhesion promoter makes the polymers compatible/compliant or at least partially compatible.

25 Figure 4 shows by way of example two polymers that are incompatible with one another. These are polystyrene and polyethylene. These polymers do not form any connection or bridges with one another. It is only in the presence of an adhesion promoter in the form of a  
30 styrene-butadiene copolymer that a connection is made between the two.

Two exemplary embodiments of coextruded pencils are illustrated below, in which an adhesion promoter layer  
35 is inserted between the lead and the wood substitute material, in order to connect inherently non-compliant or incompatible polymer groups to one another. In

- 7 -

addition, these pencils may be provided with a decorative layer.

5 Exemplary embodiment 1, pencil with polymer layer composition

Lead	Polystyrene (PS)
Adhesion promoter/lead casing	Styrene-butadiene copolymer (SB)
10 Wood substitute (WPC)	Polyolefin (PE-HD)
Decoration	TPE

15 Exemplary embodiment 2, pencil with polymer layer composition

Lead	(SAN)
Adhesion promoter/lead casing	Styrene-butadiene copolymer (SB)
Wood substitute (WPC)	Polyolefin (PE)
20 Decoration	Polypropylene (PP)

It has proved particularly successful for the at least one polymer-bonded wood substitute material to be made up of

25

15 - 30 % by wt.	of at least one polyolefin,
50 - 80 % by wt.	of at least one organic filler,
0 - 20 % by wt.	of at least one inorganic filler,
0.5 - 5 % by wt.	of at least one adhesion promoter,
30 1 - 30 % by wt.	of at least one wax,
0 - 10 % by wt.	of at least one dye pigment and
0 - 10 % by wt.	of at least one additive.

35 For sharpenability, it is advantageous for the at least one wax in the wood substitute material to be chosen from the group of waxes comprising amide waxes, fatty

- 8 -

acids, such as stearic acid and palmitic acid, montan waxes, stearates, fatty acid esters, paraffin waxes.

5 For sharpenability, it is particularly advantageous for the at least one wax in the wood substitute material to be formed from amide wax and/or stearic acid.

10 For sharpenability, it proved most beneficial for the at least one wax in the wood substitute material to be formed from a combination of amide wax and stearic acid, wherein the ratio of amide wax to stearic acid ranges from 1:0.5 to 1:2.

15 So that the wood substitute material takes on a wood-like character, it is advantageous for the at least one organic filler to be made from wood and/or cellulose. For sharpenability, it is particularly advantageous for the at least one organic filler to be formed from filler particles with a maximum particle size of 250  
20  $\mu\text{m}$ , particularly of maximum 100  $\mu\text{m}$ .

An adhesion promoter is needed to connect wood with a polar surface and polyolefins with a non-polar surface. Since adhesion promoters for polyethylene (PE) and  
25 polypropylene (PP) are available on the market, it is advantageous for the polyolefin to be formed from polyethylene (PE) and/or polypropylene (PP).

30 An adhesion promoter formed by a polyethylene (PE) with maleic acid anhydride grafted on has proved successful in connecting wood and PE.

35 To achieve a flexural strength of over 50 MPa and a modulus of elasticity of over 5000 MPa, it is particularly advantageous if the at least one polyolefin is formed from polyethylene high-density (PE-HD).

- 9 -

In order to lighten the colour shade of the wood substitute material, it has proved successful for the wood substitute material to contain 1 to 3 % by wt white dye pigment.

5

To lighten the colour shade, it proved advantageous for the white dye pigment to be formed from titanium dioxide (TiO<sub>2</sub>).

10 To set the desired colour tone, it is advantageous for the wood substitute material to contain 0.1 to 5 % by wt. coloured dye pigment.

15 To set the brittleness and sliding properties during sharpening, it is advantageous for the at least one inorganic filler in the wood substitute material to be chosen from the group of fillers made up of layer silicates, calcium sulphate, calcium carbonate, boron nitride, soapstone, graphite.

20

In order to achieve special properties and satisfy particular requirements, it is advantageous for the at least one additive in the wood substitute material to be chosen from the group of additives comprising anti-  
25 friction agents, softening agents, surface-active substances, thermal stabilisers, UV stabilisers.

30 Given below are two sample formulations for the wood substitute material that have proved successful for extrusion:

Sample wood substitute material formulation 1

	Polyethylene high-density (PE-HD)	25.0 % by wt
35	Wood dust	65.0 % by wt
	Polyethylene with grafted maleic acid anhydride	2.0 % by wt

- 10 -

	Amide wax	3.0 % by wt
	Stearic acid	3.0 % by wt
	Titanium dioxide	2.0 % by wt
5	Sample wood substitute material formulation 2	
	Polypropylene (PP)	20.0 % by wt
	Wood dust	70.0 % by wt
10	Polypropylene with grafted maleic acid anhydride	1.0 % by wt
	Amide wax	3.0 % by wt
	Stearic acid	1.0 % by wt
	Boron nitride	5.0 % by wt
15	A polymer-bound lead made from	
	10 to 30 % by wt	polystyrene or styrene acrylonitrile (SAN)
	2 to 25 % by wt	wax
20	0.1 to 5 % by wt	palm oil
	remainder	filler(s)

combined with the wood substitute material described above has proved successful.

25

This lead composition has outstanding extrusion properties. Surprisingly, it has emerged that through the targeted use of palm oil as a lead component, an internal anti-friction agent is added to the formulation, which causes the extrusion pressure in an extruder to be reduced significantly. The palm oil additive in the lead composition produces in particular a significant reduction in the compression or extrusion pressure at the extruder mouth or head during extrusion. During this process, the pressure drops as the quantity of palm oil added increases, with a reduction in pressure by at least 30 %, particularly by

30

35

- 11 -

at least 50 %, being achieved compared with traditional extrudable lead compositions.

5 It has been established that although other natural or synthetic oils also reduce the pressure in an extruder, they have a disproportionately high detrimental effect on the strength of the extruded lead. Surprisingly, this is not the case when using palm oil, as the pressure in the extruder is low and the required level  
10 of strength in the lead therefore exists.

The typical fatty acid distribution of palm oil is composed as follows (in % by wt):

15	C12: lauric acid	0 - 1 %
	C14: myristic acid	0 - 3 %
	C16: palmitic acid	36 - 47 %
	C18: stearic acid	2 - 8 %
	C18: oleic acid	36 - 42 %
20	C18: linoleic acid	7 - 12 %
	C18: linolenic acid	0 - 1 %
	Other:	max. 1 %

In addition, the palm oil produces a stronger  
25 impression of colour in the lead coating and improves its sliding properties during writing. In the case of pencil leads, a rich downstroke with a high optical density emerges, while coloured pencil leads produce a rich, luminously strong shade of colour in the  
30 downstroke.

The proportion of palm oil in the lead composition ranges from 0.1 to 5 % by wt, particularly from 0.5 to 2.5 % by wt. If the palm oil content exceeds the  
35 preceding limit of 5 % by wt, the strength of the lead is reduced by a disproportionately high degree, even

- 12 -

when using palm oil. The leads then tend to crumble or break during use.

The waxes used in the lead are kneadable at 20 °C, solid to brittle-hard, display a coarse to fine-crystalline structure, are translucent to opaque in colour, but not vitreous, and melt at over 40 °C without decomposing. They are readily liquid at a little above the melting point and have a heavily temperature-dependent consistency and solubility.

The polymer-bonded leads are unbaked leads that can be used without further heat treatment or impregnation.

It is particularly preferable for the polymer-bonded lead to contain

15 to 25 % by wt	polystyrene or SAN
4 to 20 % by wt	wax
0.5 to 2.5 % by wt	palm oil and
remainder	filler(s).

It has further proved successful for the at least one wax in the lead to be at least one from the group made up of stearates, montan waxes, amide waxes, paraffins. Mixtures of two or more waxes can also be used in the wax.

In this case, it is particularly preferable for the at least one wax in the lead to be formed from calcium stearate or to include calcium stearate.

Advantageously, the at least one filler in the lead is formed from at least one filler from the group comprising graphite, soot, hexagonal boron nitride, layer silicates, chalk, barium sulphate, coloured pigments, achromatic pigments.

- 13 -

For pencil leads, particular preference is given to graphite or graphite combined with soot as the colour-delivering fillers. For coloured pencil leads, combinations of white or colourless fillers, such as  
 5 hexagonal boron nitride, layer silicates, etc. with colour-delivering pigments, such as azo pigments, phthalocyanine, dioxazine, chinacridone, iron oxides, soot, graphite, ultramarine, iron-cyan complexes have proved successful.

10

A preferred composition for a pencil lead is made up of:

15	15 to 25 % by wt	polystyrene or styrene acrylonitrile
	4 to 12 % by wt	wax
	0.5 to 2 % by wt	palm oil and
	remainder	graphite or graphite and soot

20 A pencil lead particularly displays:

	15 to 25 % by wt	polystyrene (PS) or styrene acrylonitrile
	4 to 12 % by wt	calcium stearate
25	0.5 to 2 % by wt	palm oil and
	remainder	graphite or graphite and soot

A formulation 1 for a pencil lead indicated by way of example comprises:

30

	Polystyrene (PS)	21 % by wt
	Calcium stearate	6 % by wt
	Palm oil	1.0 % by wt
	Graphite	remainder

35

- 14 -

An exemplary formulation 2 for a pencil lead comprises:

	Styrene acrylonitrile (SAN)	15 % by wt
	Aluminium stearate	10 % by wt
5	Palm oil	2 % by wt
	Graphite	remainder

A preferred composition for a coloured pencil lead comprises:

10	15 to 25 % by wt	polystyrene or SAN
	4 to 12 % by wt	wax
	0.5 to 2 % by wt	palm oil and
	remainder	layer silicate(s) and/or
15		hexagonal boron nitride and at
		least one coloured pigment
		and/or an achromatic pigment

A coloured pencil particularly displays:

20	15 to 25 % by wt	polystyrene (PS)
	4 to 12 % by wt	montan waxes
	0.5 to 2 % by wt	palm oil and
	remainder	talcum and/or hexagonal boron
25		nitride and at least one
		coloured pigment and/or an
		achromatic pigment

For the writing, drawing, decorating or cosmetic pencil according to the invention, it has proved successful for there to be at least one decorative layer on the side of the wood substitute material facing away from the lead. This replaces the traditional coat of paint and is particularly coloured and/or provided with a manufacturer-typical stamp.

- 15 -

In this case, it has proved successful for the at least one decorative layer to be a polymer-bonded decorative layer, which is compatible with the at least one further polymer in the wood substitute material.

5

Alternatively, it is possible for the at least one decorative layer to be a polymer-bonded decorative layer, which is incompatible with the at least one further polymer in the wood substitute material and for there to be at least one further adhesion promoter layer between the wood substitute material and the at least one decorative layer, wherein the at least one further adhesion promoter layer, on the one hand, is connected to the at least one further polymer in the wood substitute material and, on the other, to the polymer in the at least one decorative layer.

10  
15

The object is achieved for the method of producing a writing, drawing, decorating or cosmetic pencil, in that the lead, the at least one adhesion promoter layer and the wood substitute material are coextruded.

20

The object is achieved for the method of producing a writing, drawing, decorating or cosmetic pencil, in that the lead, the at least one adhesion promoter layer, the wood substitute material, optionally the at least one further adhesion promoter layer and the at least one decorative layer are coextruded.

25

While the pencil is coextruded, the different components (lead, adhesion promoter, wood substitute material and decoration) are each fused in an extruder and the viscous melt is conveyed to a joint mould. In this mould, the individual components are geometrically preformed, combined together and jointly ejected. After leaving the mould, the continuous strand extruded in this way is cooled and solidifies in the present

30  
35

- 16 -

geometry. The continuous strand is separated following cooling, the pieces are conveyed to follow-on units for decoration (foil stamping) and finishing (sharpening).

- 5 Based on the production process and the outstanding  
adhesion created between the lead and the wood  
substitute material, it is possible for the wood  
substitute material to be formed in a wide variety of  
designs. Hence, the wood substitute material may  
10 surround the lead as a closed ring, viewed in cross-  
section, may be formed as circular segments or extend  
in a spiral along the lead.

- 17 -

**CLAIMS:**

1. A writing, drawing, decorating or cosmetic pencil comprising a colour-delivering, polymer-bonded lead and a polymer-bonded wood substitute material, wherein the wood substitute material at least partly covers or surrounds the lead along its length and comprises at least one organic filler and wherein at least one adhesion promoter layer is disposed between the lead and the wood substitute material, wherein the lead and the wood substitute material each have at least one polymer, the at least one polymer in the lead being incompatible with the at least one further polymer in the wood substitute material, in such a manner that the at least one polymer of the lead and the at least one further polymer of the wood substitute material do not create any connection with one another and the at least one adhesion promoter layer is connected on the one hand to the at least one polymer in the lead and on the other hand to the at least one further polymer in the wood substitute material in such a manner that the at least one adhesion promoter layer forms a connection with the at least one polymer in the lead and on the other hand with the at least one further polymer of the wood substitute material and wherein the at least one organic filler is formed from filler particles having a maximum particle size of 250  $\mu\text{m}$ .

2. The writing, drawing, decorating or cosmetic pencil according to claim 1, wherein the at least one polymer in the lead is made from polystyrene or SAN.

3. The writing, drawing, decorating or cosmetic pencil according to claim 1 or 2, wherein the at least one further polymer in the wood substitute material is chosen from the group of polyolefins.

- 18 -

4. The writing, drawing, decorating or cosmetic pencil according to any one of the claims 1 to 3, wherein the at least one adhesion promoter layer is formed from a copolymer, a block polymer, a graft polymer or a polymer blend.

5. The writing, drawing, decorating or cosmetic pencil according to any one of the claims 1 to 4, wherein the at least one adhesion promoter layer is formed from a styrene-butadiene copolymer and/or a styrene/ethene-butene/styrene block copolymer.

6. The writing, drawing, decorating or cosmetic pencil according to any one of the claims 1 to 5, wherein the at least one polymer-bonded wood substitute material is made up of

15 - 30 % by wt.	of at least one polyolefin,
50 - 80 % by wt.	of at least one organic filler,
0 - 20 % by wt.	of at least one inorganic filler,
0.5 - 5 % by wt.	of at least one adhesion promoter,
1 - 30 % by wt.	of at least one wax,
0 - 10 % by wt.	of at least one dye pigment and
0 - 10 % by wt.	of at least one additive.

7. The writing, drawing, decorating or cosmetic pencil according to any one of the claims 1 to 6, wherein the polymer-bound lead is made from

10 to 30 % by wt	polystyrene or styrene acrylo-nitrile (SAN)
2 to 25 % by wt	wax
0.1 to 5 % by wt	palm oil
remainder	filler(s).

- 19 -

8. The writing, drawing, decorating or cosmetic pencil according to any one of the claims 1 to 7, wherein at least one decorative layer is disposed on the side of the wood substitute material facing away from the lead.

9. The writing, drawing, decorating or cosmetic pencil according to claim 8, wherein the at least one decorative layer is a polymer-bonded decorative layer, which is compatible with the at least one further polymer in the wood substitute material.

10. The writing, drawing, decorating or cosmetic pencil according to claim 8, wherein the at least one decorative layer is a polymer-bonded decorative layer, which is incompatible with the at least one further polymer in the wood substitute material, in such a manner that the at least one decorative layer and the at least one further polymer of the wood substitute material do not create any connection with one another and that at least one further adhesion promoter layer is disposed between the wood substitute material and the at least one decorative layer, wherein the at least one further adhesion promoter layer, on the one hand, is connected to the at least one further polymer in the wood substitute material and, on the other, to the polymer in the at least one decorative layer in such a manner that the at least one further adhesion promoter layer forms a connection with the at least one decorative layer and on the other hand with the at least one further polymer of the wood substitute material.

11. A method of producing the writing, drawing, decorating or cosmetic pencil of any one of the claims 1 to 8, wherein the lead, the at least one adhesion promoter layer and the wood substitute material are coextruded.

- 20 -

12. The method of producing the writing, drawing, decorating or cosmetic pencil of any one of the claims 8 to 10, wherein the lead, the at least one adhesion promoter layer, the wood substitute material, optionally the at least one further adhesion promoter layer and the at least one decorative layer are coextruded.

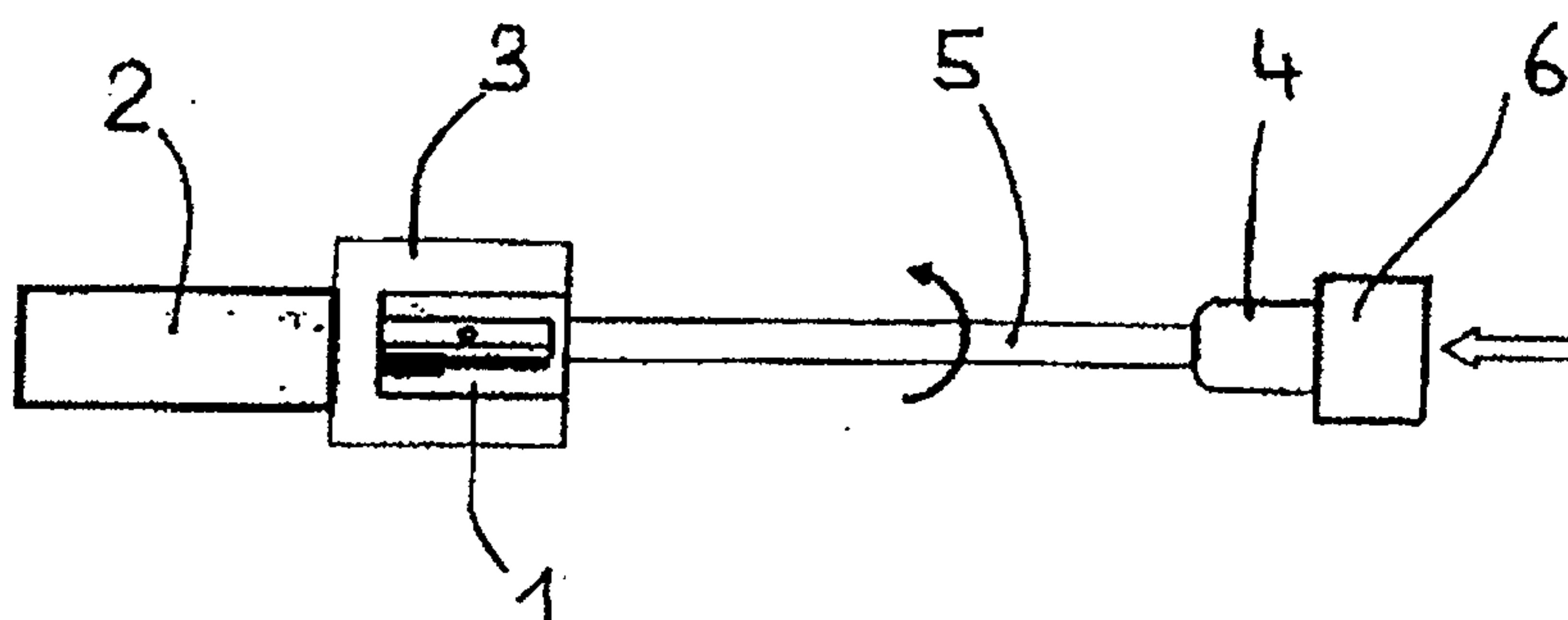

FIGURE 1

PRIOR ART

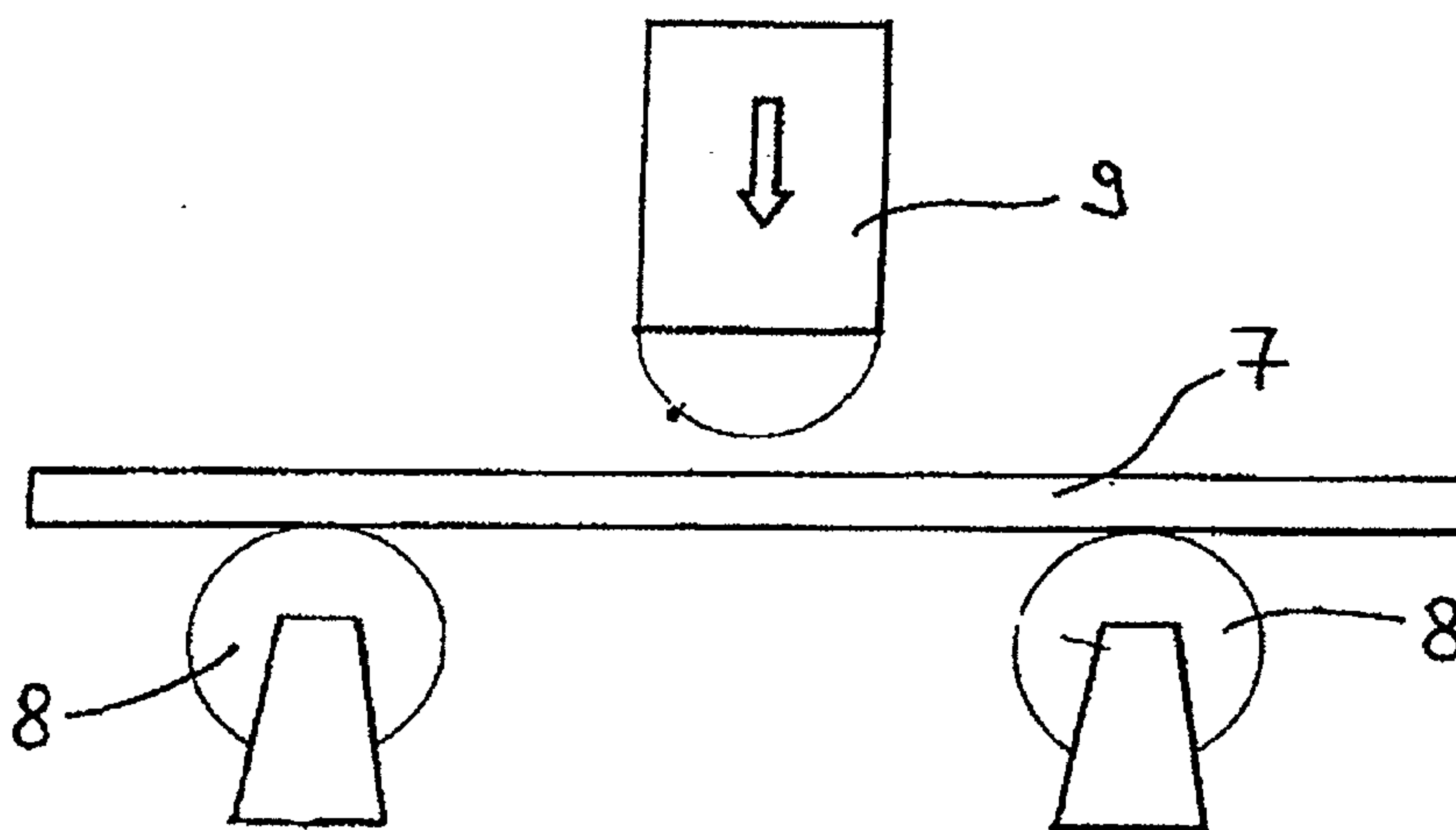

FIGURE 2

PRIOR ART

2/3

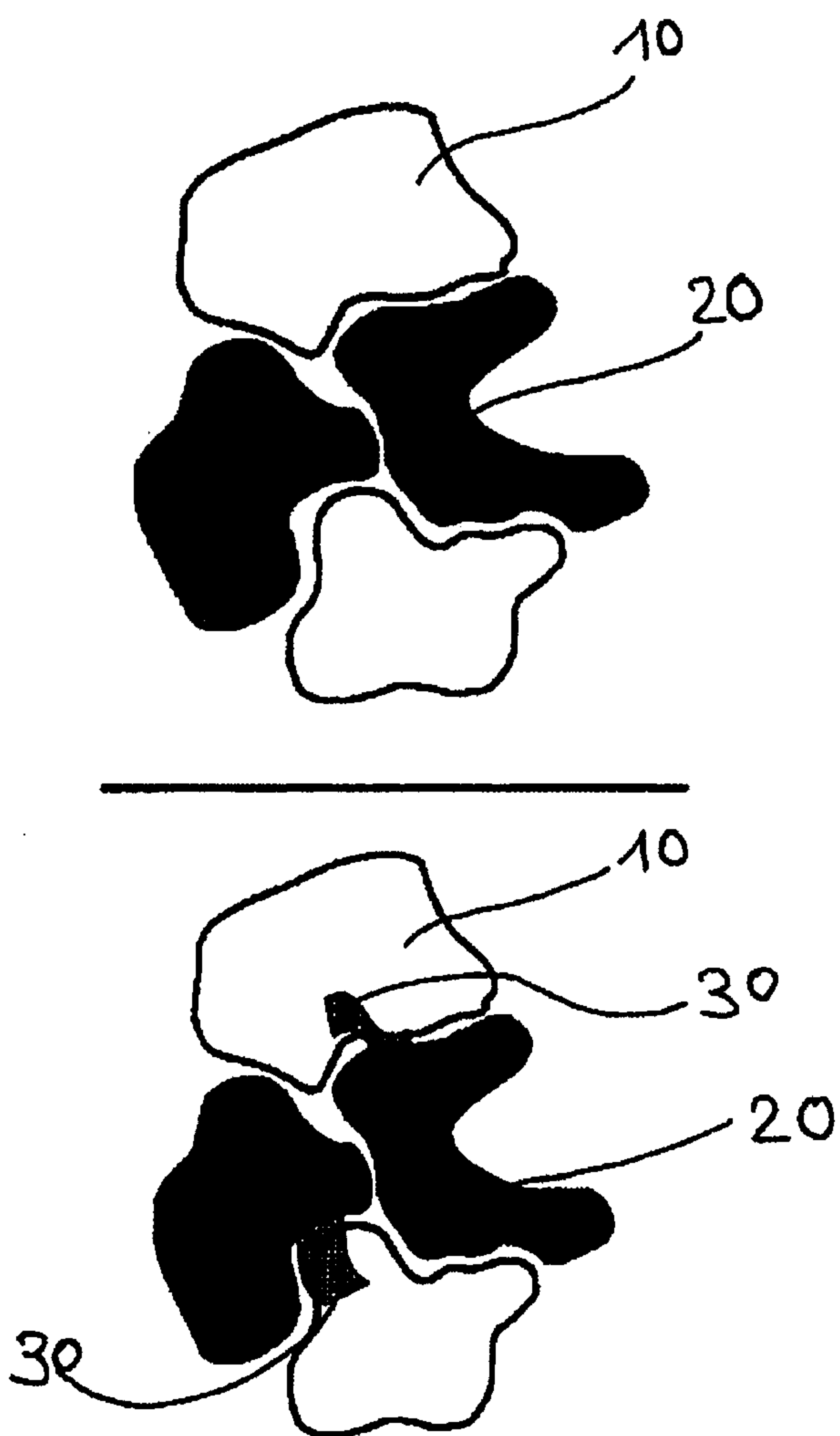

FIGURE 3

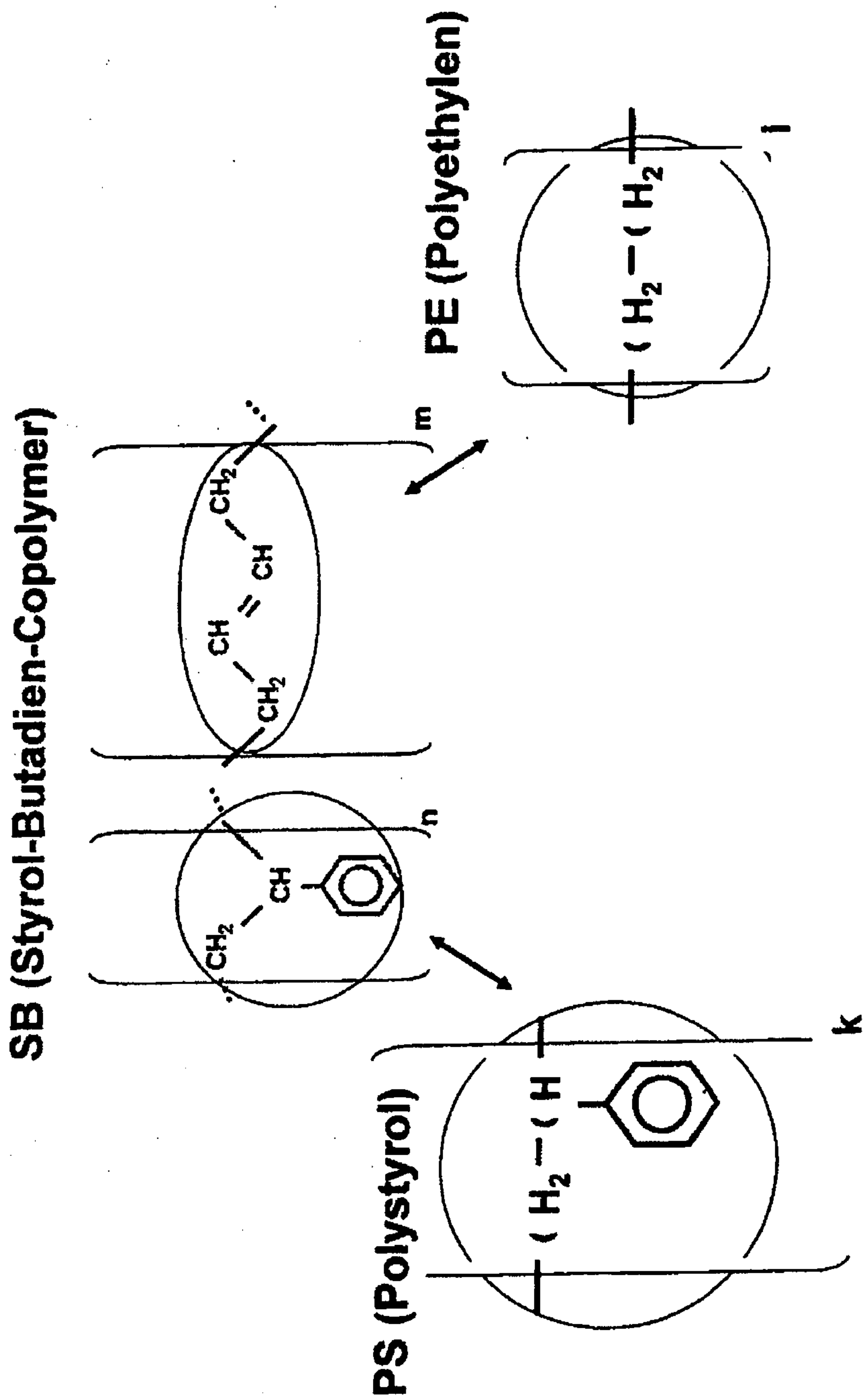

FIGURE4

