



US 20170137997A1

(19) **United States**

(12) **Patent Application Publication**

Xu et al.

(10) **Pub. No.: US 2017/0137997 A1**

(43) **Pub. Date: May 18, 2017**

(54) **POLYURETHANE ROLL COVER FOR CALENDER ROLL FOR PAPERMAKING MACHINE**

Publication Classification

(51) **Int. Cl.**
D21G 1/02 (2006.01)
B32B 5/02 (2006.01)
B32B 27/40 (2006.01)

(52) **U.S. Cl.**
 CPC *D21G 1/0246* (2013.01); *B32B 27/40* (2013.01); *B32B 5/02* (2013.01)

(71) Applicant: **Stowe Woodward Licensco, LLC**, Raleigh, NC (US)

(72) Inventors: **Jun Xu**, Frederick, MD (US); **Christopher Hill**, Strasburg, VA (US); **Christopher Tyson**, Clear Brook, VA (US); **Charles Hunter**, Winchester, VA (US)

(21) Appl. No.: **15/339,977**

(22) Filed: **Nov. 1, 2016**

Related U.S. Application Data

(60) Provisional application No. 62/256,312, filed on Nov. 17, 2015.

(57) **ABSTRACT**

A calender roll for a papermaking machine includes: a substantially cylindrical core; and a cover circumferentially surrounding the core. The cover comprises: a base layer circumferentially overlying the core; and a topstock layer comprising polyurethane circumferentially overlying the base layer, the topstock layer being fiber-reinforced, the polyurethane having a glass transition temperature of between about 120 and 150° C., the topstock layer having a hardness of 70 to 90 ShD.

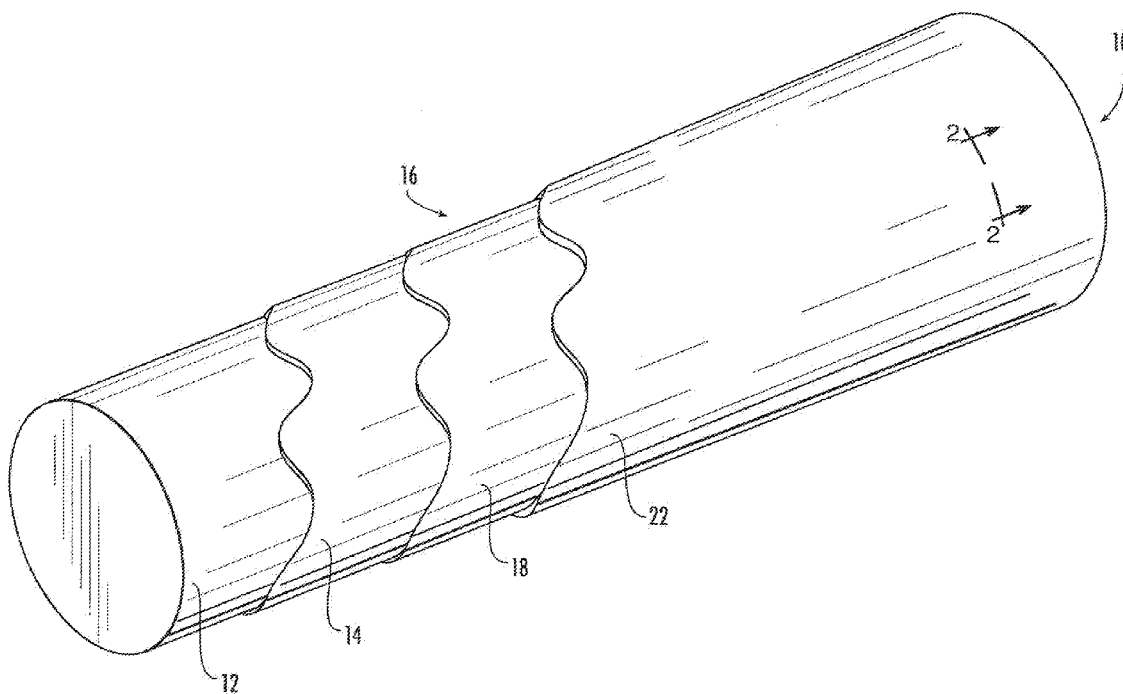

**POLYURETHANE ROLL COVER FOR
CALENDER ROLL FOR PAPERMAKING
MACHINE**

RELATED APPLICATION

[0001] The present application claims priority from and the benefit of U.S. Provisional Patent Application No. 62/256,312, filed Nov. 17, 2015, the disclosure of which is hereby incorporated herein in its entirety.

FIELD OF THE INVENTION

[0002] The present invention relates generally to covers for industrial rolls, and more particularly to polyurethane covers for industrial rolls.

BACKGROUND OF THE INVENTION

[0003] In a typical papermaking process, a water slurry, or suspension, of cellulosic fibers (known as the paper “stock”) is fed onto the top of the upper run of an endless belt of woven wire and/or synthetic material that travels between two or more rolls. The belt, often referred to as a “forming fabric,” provides a papermaking surface on the upper surface of its upper run which, operates as a filter to separate the cellulosic fibers of the paper stock from the aqueous medium, thereby forming a wet paper web. The aqueous medium drains through mesh openings of the forming fabric, known as drainage holes, by gravity or vacuum located on the lower surface of the upper run (i.e., the “machine side”) of the fabric.

[0004] After leaving the forming section, the paper web is transferred to a press section of the paper machine, where it is passed through the nips of one or more presses (often roller presses) covered with another fabric, typically referred to as a “press felt.” Pressure from the presses removes additional moisture from the web; the moisture removal is often enhanced by the presence of a “batt” layer of the press felt. The paper is then transferred to a dryer section for further moisture removal. After drying, the paper is ready for secondary processing (often in a calender section of the papermaking machine) and packaging.

[0005] Cylindrical rolls are typically utilized in different sections of a papermaking machine. Such rolls reside and operate in demanding environments in which they can be exposed to high dynamic loads and temperatures and aggressive or corrosive chemical agents. As an example, in a typical paper mill, rolls are used not only for transporting the fibrous web sheet between processing stations, but also, in the case of press section and calender rolls, for processing the web sheet itself into paper.

[0006] Typically rolls used in papermaking are constructed with the location within the papermaking machine in mind, as rolls residing in different positions within the papermaking machines are required to perform different functions. Because papermaking rolls can have many different performance demands, and because replacing an entire metallic roll can be quite expensive, many papermaking rolls include a polymeric cover that surrounds the circumferential surface of a typically metallic core. By varying the material employed in the cover, the cover designer can provide the roll with different performance characteristics as the papermaking application demands. Also, repairing, regrinding or replacing a cover over a metallic roll can be considerably less expensive than the

replacement of an entire metallic roll. Exemplary polymeric materials for covers include natural rubber, synthetic rubbers such as neoprene, styrene-butadiene (SBR), nitrile rubber, chlorosulfonated polyethylene (“CSPE”—also known under the trade name HYPALON® from DuPont), EDAM (the name given to an ethylene-propylene terpolymer formed of ethylene-propylene diene monomer), polyurethane, thermoset composites, and thermoplastic composites.

[0007] In many instances, the roll cover will include at least two distinct layers; a base layer that overlies the core and provides a bond thereto; and a topstock layer that overlies and bonds to the base layer and serves as the outer surface of the roll (some rolls will also include an intermediate “tie-in” layer sandwiched by the base and top stock layers). The layers for these materials are typically selected to provide the cover with a prescribed Set of physical properties for operation. These can include the requisite strength, elastic modulus, and resistance to elevated temperature, water and harsh chemicals to withstand the papermaking environment. In addition, covers are typically designed to have a predetermined surface hardness that is appropriate for the process they are to perform, and they typically require that the paper sheet “release” from the cover without damage to the paper sheet. Also, in order to be economical, the cover should be abrasion- and wear-resistant.

[0008] Calender rolls, which are typically employed in a calender section located downstream of the dryer section of the papermaking machine, are employed to finish the paper to a desired smoothness and finish. Calender rolls are typically required to have a high modulus of elasticity (i.e., rigidity), abrasion resistance, toughness, glass transition temperature (T_g) and barring resistance. Typical compounds for calender roll covers are epoxies, given their high modulus and T_g, but these compounds often lack toughness. As such, alternative materials for use in calender applications may be desirable.

SUMMARY

[0009] As a first aspect, embodiments of the invention are directed to a calender roll for a papermaking machine comprising: a substantially cylindrical core; and a cover circumferentially surrounding the core. The cover comprises: a base layer circumferentially overlying the core; and a topstock layer comprising polyurethane circumferentially overlying the base layer, the topstock layer being fiber-reinforced, the polyurethane having a glass transition temperature of between about 120 and 150° C., the topstock layer having a hardness of 70 to 90 ShD.

[0010] As a second aspect, embodiments of the invention are directed to a calender roll for a papermaking machine comprising: a substantially cylindrical core; and a cover circumferentially surrounding the core. The cover comprises: a base layer circumferentially overlying the core; and a topstock layer comprising polyurethane circumferentially overlying the base layer, the topstock layer being fiber-reinforced, the polyurethane having a strain at failure of between about 7 and 12 percent, the topstock layer having a hardness of 70 to 90 ShD.

[0011] As a third aspect, embodiments of the invention are directed to a calender roll for a papermaking machine comprising: a substantially cylindrical core; and a cover circumferentially surrounding the core. The cover comprises: a base layer circumferentially overlying the core; and

a topstock layer comprising polyurethane circumferentially overlying the base layer, the topstock layer being fiber-reinforced, wherein the polyurethane is prepared from a mixture comprising an isocyanate, a catalyst and a hardener, and wherein the isocyanate is included at a weight percent of between about 70 and 85 percent, and the catalyst is included at a weight percent of between about 10 and 20 percent; the polyurethane having a glass transition temperature of between, about 120 and 150°C and a strain at failure of between about 7 and 12 percent, the topstock layer having a hardness of 70 to 90 ShD.

BRIEF DESCRIPTION OF THE FIGURES

[0012] FIG. 1 is a perspective cutaway view of an industrial roll according to embodiments of the present invention.

[0013] FIG. 2 is a greatly enlarged, partial section view of the roll of FIG. 1 taken along lines 2-2 thereof.

DETAILED DESCRIPTION OF EMBODIMENTS OF THE INVENTION

[0014] The present invention will be described more particularly hereinafter with reference to the accompanying drawings. The invention is not intended to be limited to the illustrated embodiments; rather, these embodiments are intended to fully and completely disclose the invention to those skilled in this art. In the drawings, like numbers refer to like elements throughout. Thicknesses and dimensions of some components may be exaggerated for clarity. Well-known functions or constructions may not be described in detail for brevity and/or clarity.

[0015] In addition, spatially relative terms, such as “under”, “below”, “lower”, “over”, “upper” and the like, may be used herein for ease of description to describe one element or feature’s relationship to another element(s) or feature(s) as illustrated in the figures. It will be understood that the spatially relative terms are intended to encompass different orientations of the device in use or operation in addition to the orientation depicted in the figures. For example, if the device in the figures is turned over, elements described as “under” or “beneath” other elements or features would then be oriented “over” the other elements or features. Thus, the exemplary term “under” can encompass both an orientation of over and under. The device may be otherwise oriented (rotated 90 degrees or at other orientations) and the spatially relative descriptors used herein interpreted accordingly.

[0016] Unless otherwise defined, all technical and scientific terms used herein have the same meaning as commonly understood by one of ordinary skill in the art to which this invention belongs. The terminology used in the description of the invention herein is for the purpose of describing particular embodiments only and is not intended to be limiting of the invention. As used in the description of the invention and the appended claims, the singular forms “a,” “an” and “the” are intended to include the plural forms as well, unless the context clearly indicates otherwise. As used herein, the term “and/or” includes any and, all combinations of one or more of the associated listed items. Where used, the terms “attached,” “connected,” “interconnected,” “contacting,” “coupled,” “mounted,” “overlying” and the like can mean either direct or indirect attachment or contact between elements, unless stated otherwise.

[0017] The term “about,” as used herein when referring to a measurable value, such as an amount or concentration, encompasses variations of the specified measurable value as well as the specified value, and may encompass variations of $\pm 10\%$, $\pm 5\%$, $\pm 1\%$, $\pm 0.5\%$, $\pm 0.1\%$, or the like. For example, “about X” where X is the measurable value, is meant to include X as well as variations of X that may include $\pm 10\%$, $\pm 5\%$, $\pm 1\%$, $\pm 0.5\%$, $\pm 0.1\%$, or the like. A range provided herein for a measurable value may include any other range and/or individual value therein.

[0018] Referring now to the figures, a calender roll, designated broadly at **10**, is illustrated in FIGS. 1 and 2. The roll **10** includes in overlying relationship a core **12** (typically metallic), an adhesive layer **14**, and a cover **16**. Each of these components is discussed in greater detail herein below.

[0019] The core **12** is a substantially cylindrical, hollow structure typically formed of steel, some other metal, or even a composite material. The core **12** is typically between about 1.5 and 400 inches in length and about 1 and 70 inches in diameter, with lengths between about 100 and 400 inches and diameters of between about 20 and 70 inches being common for papermaking purposes. At these more common length and diameter ranges, the core **12** typically has walls between about 1 and 5 inches in thickness. Components such as journals and bearings (not shown) are typically included on the core **12** to facilitate its mounting and rotation in a papermaking machine. The surface of the core **12** may be treated by blasting, sanding, sandblasting, or the like to prepare the surface for bonding to the adhesive layer **14**.

[0020] Referring again to FIGS. 1 and 2, the adhesive layer **14** comprises an adhesive (typically an epoxy adhesive) that can attach the core **12** to the cover **16**. Of course, the adhesive comprising the adhesive layer **14** should be chosen to be compatible with the materials of the core **12** and the base layer **18** of the cover **16** (i.e., it should provide a high-integrity bond between these structures without unduly harming either material); preferably, the bond has a tensile bond strength of between about 1,200 and 5,000 psi. The adhesive may have additives, such as curing agents, that facilitate curing and physical properties. Exemplary adhesives include Chemlok 220X and Chemlok 205, which are epoxy adhesives available from Lord Corporation, Raleigh, N.C.

[0021] The adhesive layer **14** can be applied to the core **12** in any manner known to be suitable to those skilled in this art for applying a thin layer of material. Exemplary application techniques include spraying, brushing, immersion, scraping, and the like. It is preferred that, if a solvent-based adhesive is used, the adhesive layer **14** be applied such that the solvent can evaporate prior to the application of the cover **16** in order to reduce the occurrence of trapped solvent that can cause “blows” during the curing process. Those skilled in this art will appreciate that the adhesive layer **14** may comprise multiple coats of adhesive, which may comprise different adhesives; for example, two different epoxy adhesives with slightly different properties may be employed. It should also be noted that, in some embodiments, the adhesive layer may be omitted entirely, such that the cover **16** is bonded directly to the core **12**.

[0022] Still referring to FIGS. 1 and 2, the cover **16** comprises, in overlying relationship, a base layer **18** and a topstock layer **22**. In the illustrated embodiment, the base layer **18** is adhered to the adhesive layer **14**. The base layer

18 comprises a polymeric compound (typically a thermoset-based composite, such as epoxy) that typically, includes fillers and other additives.

[0023] Fillers are typically added to the base layer **18** to modify the physical properties of the polymeric compound and/or to reduce its cost. Exemplary filler materials include, but are not limited to, inorganic oxides such as aluminum oxide (Al_2O_3), silicon dioxide (SiO_2), magnesium oxide (MgO), calcium oxide (CaO); zinc oxide (ZnO) and titanium dioxide (TiO_2); carbon black (also known as furnace black); silicates such as clays, talc, wollastonite (CaSiO_3), magnesium silicate (MgSiO_3), anhydrous aluminum silicate, and feldspar (KAlSi_3O_8); sulfates such as barium sulfate and calcium sulfate; metallic powders such as aluminum, iron, copper, stainless steel, and nickel carbonates such as calcium carbonate (CaCO_3) and magnesium carbonate (MgCO_3); mica; silica (natural, fumed, hydrated, anhydrous or precipitated); and nitrides and carbides, such as silicon carbide (SiC) and aluminum nitride (AlN). These fillers may be present in virtually any form, such as powder, pellet, fiber or sphere.

[0024] Also, the base layer **18** may optionally include other additives, such as polymerization initiators, activators and accelerators, curing or vulcanizing agents, plasticizers, heat stabilizers, antioxidants and antiozonants, coupling agents, pigments, and the like, that can facilitate processing and enhance physical properties. These components are generally compounded into the polymer prior to the time of application of the base layer **18** to the adhesive layer **14** or directly to the core **12**. Those skilled in this art will appreciate that the identity and amounts of these agents and their use in a base layer are generally known and need not be described in detail herein.

[0025] The base layer **18** can be applied by any manner known to those skilled in this art to be suitable for the application of polymers to an underlying surface. The thickness of the base layer **18** is typically between about 0.0625 inches and about 1 inch, in some embodiments between about 0.1 inches and about 0.5 inches, and in further embodiments between about 0.1 inches and about 0.25 inches. Those skilled in this art will appreciate that, in some embodiments, the base layer **18** may be omitted such that the topstock layer **22** is adhered directly to the adhesive layer **14** or, in the absence of an adhesive layer, to the core **12**.

[0026] Referring again to FIGS. 1 and 2, in the illustrated embodiment, the topstock layer **22** circumferentially overlies and, unless one or more tie-in layers are included as described below, is adhered to the base layer **18**. The topstock layer **22** comprises a polyurethane compound that has a high Tg and is reinforced with fiber, as is described in greater detail below.

[0027] The polyurethane compound of the topstock layer **22** is typically formed of and prepared from an isocyanate (such as methylene diphenyl diisocyanate (MDI)), a polyol catalyst (such as polytetramethylene ether glycol), and a hardener (such as 4,4'-Methylenebis(3-Chloro-2,6-Diethyl-aniline)). In some embodiments, the weight percent of isocyanate is between about 70 and 85 percent, the weight percent of catalyst is between about 10 and 20 percent, and the weight percent of hardener is between about 2 and 10 percent. In one embodiment, the polyurethane comprises a compound having the properties listed in Table 1 when molded as a neat resin.

TABLE 1

Property	Units	ASTM Test Method	Value
Tensile Modulus	GPa	D-638	2.6-3.3
Tensile Break Strength	MPa		60-100
Strain at Failure	%		7-12
Water Absorption (24 Hr Immersion)	Wt %	D-570	0.3-0.4
Water Absorption (24 H, 80° C., 95% RH)	Wt %	HPU Spec.	1.0-1.5
Hardness	Shore D	D-2240	70-90
Specific Gravity		D-792	1.23
Tg by DMA E' Onset	° C.	D-7028	120-150
Tg by DMA tan δ peak	° C.		130-160

[0028] An exemplary polyurethane compound is EXP 393/394/395, provided by Huntsman Polyurethanes (The Woodlands, Tex.). The compound has an isocyanate/catalyst/hardener ratio of approximately 80/15/5 percent by weight. The physical properties of this compound are listed below in Table 2.

TABLE 2

Property	Units	ASTM Test Method	Value
Tensile Modulus	GPa	D-638	2.85
Tensile Break Strength	MPa		84.5
Strain at Failure	%		10.8
Water Absorption (24 Hr Immersion)	Wt %	D-570	0.33
Water Absorption (24 H, 80° C., 95% RH)	Wt %	HPU Spec.	1.25
Hardness	Shore D	D-2240	81
Specific Gravity		D-792	1.23
Tg by DMA E' Onset	° C.	D-7028	135
Tg by DMA tan δ peak	° C.		144

[0029] The polyurethane compound of the topstock layer **22** is typically reinforced with reinforcing fiber. The reinforcing fiber may be glass fiber, carbon fiber, polyester, nylon, aramid, or combinations of these materials. The reinforcing fiber may be in numerous forms, including a filament or tape, and may be woven or nonwoven.

[0030] Typically the topstock layer **22** includes fillers and other additives. Exemplary fillers include, but are not limited to, clay and other inorganic fillers such as silicone dioxide, carbon black, clay, and titanium dioxide (TiO_2) as well as others set forth hereinabove in connection with the base layer **18**. Other exemplary fillers include carbon fiber, carbon nanotubes, graphene, and metal oxides or carbides. Typically, fillers are included in an amount of between about 3 and 70 percent by weight of the topstock layer **22**. These fillers can take virtually any form, including powder, pellet, bead, fiber, sphere, particle, nanoparticle, or the like. Fillers may be included to enhance properties such as abrasion resistance, thermal expansion coefficient, thermal conductivity, electrical conductivity and dielectric constant. In one embodiment, a filler such as clay may be added in a weight percent of between and 30 and 60 parts per hundred parts of polyurethane.

[0031] Exemplary additives include but are not limited to, polymerization initiators, activators and accelerators, curing or vulcanizing agents, plasticizers, heat stabilizers, antioxidants, coupling agents, pigments, and the like, that can facilitate processing and enhance physical properties. Those skilled in this art will understand the types and concentra-

tions of additives that are appropriate for inclusion in the topstock layer **22**, so these need not be discussed in detail herein.

[0032] An exemplary formulation for the topstock layer **22** may include the components listed in Table 3.

TABLE 3

Component	Parts
Polyurethane Fillers	100
Wollastonite	50
Silicon Carbide	20

[0033] The topstock layer **22** can be applied over the base layer **18** by any technique known to those skilled in this art to be suitable for the application of elastomeric materials over a cylindrical surface, including casting, extrusion, dip pan, resin transfer molding (RTM), vacuum-assisted resin transfer molding (VARTM), reaction injection molding (RIM), vacuum infusion, and pultrusion.

[0034] In some embodiments, the topstock layer **22** is applied such that it is between about 0.25 inches and about 2.5 inches in thickness (at higher thickness, multiple passes of material may be required). In some embodiments, the topstock layer **22** has a thickness between about 0.5 inches and about 1.5 inches and in some embodiments between about 1 inch and about 1.5 inches. It is also suitable for the thickness of the top stock layer **22** be between about 50 and 90 percent of the total cover thickness (i.e., the total thickness of the combined base and topstock layers **18, 22**).

[0035] The compounds of the base layer **18** and the topstock **22** may be selected such that the base layer **18** has a higher hardness value than the topstock layer **22**. As an example, the base layer **18** may have a hardness of between about 80 and 95 ShD (in some embodiments, between about 80 and 90 ShD, and in other embodiments, between about 80 and 85 ShD), and the top stock layer **22** may have a hardness of between about 70 and 90 ShD (in some embodiments between about 75 and 85 ShD). The graduated hardness concept can reduce the bond line shear stresses that can occur due to mismatches of the elastic properties (such as elastic modulus and Poisson's ratio) of the various layers in the cover constructions. This reduction in interface shear stress can be important in maintaining cover integrity.

[0036] Those skilled in this art will also appreciate that the roll **10** may be constructed with a tie-in layer sandwiched between the base layer **18** and the topstock layer **22**, such that the tie-in layer would directly underlie, the top stock layer **22**. The typical properties of a tie-in layer are well-known to those skilled in this art and need not be described in detail herein.

[0037] Use of the aforementioned polyurethane compounds in the topstock layer **22** can provide a number of advantages. Polyurethane compounds can provide greater toughness and/or damage tolerance than the epoxy compounds typically employed. Curing time is reduced compared to epoxy. The resin viscosity of polyurethane is typically lower than that of epoxy, which can assist in filler dispersion and enables higher filler loading and can improve processing consistency and speed.

[0038] The foregoing is illustrative of the present invention and is not to be construed as limiting thereof. Although

exemplary embodiments of this invention have been described, those skilled in the art will readily appreciate that many modifications are possible in the exemplary embodiments without materially departing from the novel teachings and advantages of this invention. Accordingly, all such modifications are intended to be included within the scope of this invention as defined in the claims. The invention is defined by the following claims, with, equivalents of the claims to be included therein.

That which is claimed is:

1. A calender roll for a papermaking machine, comprising: a substantially cylindrical core; and a cover circumferentially surrounding the core, the cover comprising: a base layer circumferentially overlying the core; and a topstock layer comprising polyurethane circumferentially overlying the base layer, the topstock layer being fiber-reinforced, the polyurethane having a glass transition temperature of between about 120 and 150° C., the topstock layer having a hardness of 70 to 90 ShD.
2. The calender roll defined in claim 1, wherein the polyurethane has a strain at failure of at least 7 percent.
3. The calender roll defined in claim 1, wherein the polyurethane is prepared from a mixture comprising an isocyanate, a catalyst and a hardener.
4. The calender roll defined in claim 3, wherein the isocyanate comprises MDI.
5. The calender roll defined in claim 3, wherein the isocyanate is included at a weight percent of between about 70 and 85 percent, and the catalyst is included at a weight percent of between about 10 and 20 percent.
6. The calender roll defined in claim 1, wherein the topstock layer is reinforced with fiber selected from the group consisting of: glass, carbon, polyester, nylon, aramid, and combinations thereof.
7. The calender roll defined in claim 6, wherein the fiber comprises a filament or tape.
8. The calender roll defined in claim 1, in combination with a papermaking machine, wherein the calender roll is mounted in the calender section.
9. A calender roll for a papermaking machine, comprising: a substantially cylindrical core; and a cover circumferentially surrounding the core, the cover comprising: a base layer circumferentially overlying the core; and a topstock layer comprising polyurethane circumferentially overlying the base layer, the topstock layer being fiber-reinforced, the polyurethane having a strain at failure of between about 7 and 12 percent, the topstock layer having a hardness of 70 to 90 ShD.
10. The calender roll defined in claim 9, wherein the polyurethane is prepared from a mixture comprising an isocyanate, a catalyst and a hardener.
11. The calender roll defined in claim 10, wherein the isocyanate comprises MDI.
12. The calender roll defined in claim 10, wherein the isocyanate is included at a weight percent of between about 70 and 85 percent, and the catalyst is included at a weight percent of between about 10 and 20 percent.
13. The calender roll defined in claim 9, wherein the topstock layer is reinforced with fiber selected from the group consisting of: glass, carbon, polyester, nylon, aramid, and combinations thereof.

14. The calender roll defined in claim **13**, wherein the fiber comprises a filament or tape.

15. The calender roll defined in claim **9**, in combination with a papermaking machine, wherein the calender roll is mounted in the calender section.

16. A calender roll for a papermaking machine, comprising:

- a substantially cylindrical core; and
- a cover circumferentially surrounding the core, the cover comprising:
 - a base layer circumferentially overlying the core; and
 - a topstock layer comprising polyurethane circumferentially overlying the base layer, the topstock layer being fiber-reinforced, wherein the polyurethane is prepared from a mixture comprising an isocyanate, a catalyst and a hardener, and wherein the isocyanate is included at a weight percent of between about 70

and 85 percent, and the catalyst is included at a weight percent of between about 10 and 20 percent; the polyurethane having a glass transition temperature of between about 120 and 150° C. and a strain at failure of between about 7 and 12 percent, the topstock layer having a hardness of 70 to 90 ShD.

17. The calender roll defined in claim **16**, wherein the topstock layer is reinforced with fiber selected from the group consisting of: glass, carbon, polyester, nylon, aramid, and combinations thereof.

18. The calender roll defined in claim **17**, wherein the fiber comprises a filament or tape.

19. The calender roll defined in claim **16**, in combination with a papermaking machine, wherein the calender roll is mounted in the calender section.

* * * * *