

(12) INTERNATIONAL APPLICATION PUBLISHED UNDER THE PATENT COOPERATION TREATY (PCT)

(19) World Intellectual Property Organization
International Bureau



(43) International Publication Date
19 July 2001 (19.07.2001)

PCT

(10) International Publication Number
WO 01/51329 A2

- (51) International Patent Classification⁷: **B61B**
- (21) International Application Number: PCT/US01/00929
- (22) International Filing Date: 12 January 2001 (12.01.2001)
- (25) Filing Language: English
- (26) Publication Language: English
- (30) Priority Data:
09/481,641 12 January 2000 (12.01.2000) US
- (71) Applicant (for all designated States except US): **RIPPLE RESORT MEDIA, INC.** [US/US]; 7435 Central Avenue, Indianapolis, IN 46240 (US).
- (72) Inventor; and
- (75) Inventor/Applicant (for US only): **JAY, Matthew** [US/US]; 7435 Central Avenue, Indianapolis, IN 46240 (US).
- (74) Agents: **LEUDERS, Daniel, J. et al.**; Woodard, Emhardt, Naughton, Moriarty & McNett, Bank One Center/Tower, Suite 3700, 111 Monument Circle, Indianapolis, IN 46204 (US).
- (81) Designated States (national): AE, AG, AL, AM, AT, AU, AZ, BA, BB, BG, BR, BY, BZ, CA, CH, CN, CR, CU, CZ, DE, DK, DM, DZ, EE, ES, FI, GB, GD, GE, GH, GM, HR, HU, ID, IL, IN, IS, JP, KE, KG, KP, KR, KZ, LC, LK, LR, LS, LT, LU, LV, MA, MD, MG, MK, MN, MW, MX, MZ, NO, NZ, PL, PT, RO, RU, SD, SE, SG, SI, SK, SL, TJ, TM, TR, TT, TZ, UA, UG, US, UZ, VN, YU, ZA, ZW.
- (84) Designated States (regional): ARIPO patent (GH, GM, KE, LS, MW, MZ, SD, SL, SZ, TZ, UG, ZW), Eurasian patent (AM, AZ, BY, KG, KZ, MD, RU, TJ, TM), European patent (AT, BE, CH, CY, DE, DK, ES, FI, FR, GB, GR, IE, IT, LU, MC, NL, PT, SE, TR), OAPI patent (BF, BJ, CF, CG, CI, CM, GA, GN, GW, ML, MR, NE, SN, TD, TG).
- Published:
— without international search report and to be republished upon receipt of that report

[Continued on next page]

(54) Title: MEDIA DISPLAY SYSTEM FOR SKI-LIFT CHAIR

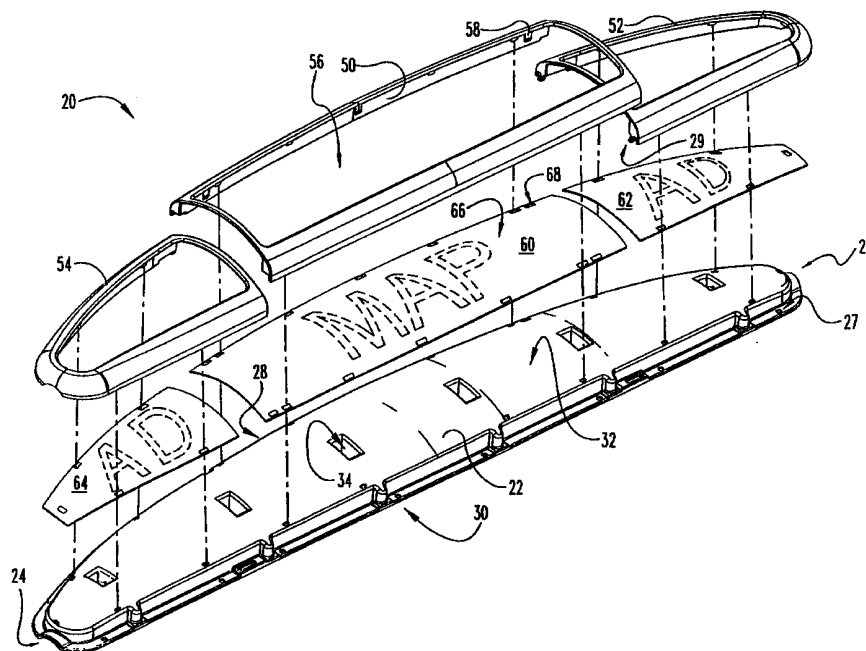

(57) Abstract: A display system for displaying media on a ski-lift chair is provided. A main body portion is disclosed, having clamps to hold it to the restraint of the ski-lift chair. A plurality of frames are provided along a top surface of the body portion for holding printable media sheets, such as maps and advertisements, in place. Printable sheets are disclosed as transparent plastic with reverse printed imagery thereon.



WO 01/51329 A2



For two-letter codes and other abbreviations, refer to the "Guidance Notes on Codes and Abbreviations" appearing at the beginning of each regular issue of the PCT Gazette.

MEDIA DISPLAY SYSTEM FOR SKI-LIFT CHAIR

5

BACKGROUND OF THE INVENTION

The present invention relates to a media display system for ski-lift chair, and more specifically such a system to be mounted to a lateral restraint along the front side of the chair which restrains people from falling out of the chair.

Skiing is a popular sport enjoyed by many people throughout the world. Ski resorts typically have ski-lifts which include ski-lift chairs having a lateral restraint crossbar across the front to prevent riders from falling out. As demonstrated by the different U.S. Patent No. 5,685,095, it is desirable to have a media display system. However, there is a need for a display system which has different and enhanced characteristics of non-rotatability, aerodynamics, interchangeability, ornamentality and/or others. These and other features are provided by various aspects of my novel device.

SUMMARY OF THE INVENTION

The present invention provides a media display system attachable to a lateral restraint along the front side of a ski-lift chair including in combination
5 some or more of the following features as set forth in the claims. A body member is provided which is attachable to a lateral restraint of the ski-lift chair. The body member may be non-rotatable. The body member may have a length in the central region which is greater than the thickness. A frame member may be located on top of the body member with a view of the region therein being adapted to hold printed
10 media, such as ski maps, advertisement or the like.

One object of the present invention is to provide an improved media display system having enhances functional and/or ornamental features.

BRIEF DESCRIPTION OF THE DRAWINGS

FIG. 1 is an exploded top rear perspective view of a media display system according to one example of the present invention;

5 FIG. 2 is a top plan view of one example of the present invention;

 FIG. 3 is a rear elevation view of the device of FIG. 2;

 FIG. 4 is a left side elevation view of the device of FIG. 2, the right side elevation view being a mirror image thereof;

 FIG. 5 is a bottom plan view of the device of FIG. 2;

10 FIG. 6 is a front elevation view of the device of FIG. 2; and

 FIG. 7 is a top rear perspective view of the device of FIG. 2.

DESCRIPTION OF THE PREFERRED EMBODIMENTS

For the purposes of promoting an understanding of the principles of the invention, reference will now be made to the embodiment illustrated in the drawings and specific language will be used to describe the same. It will nevertheless be understood that no limitation of the scope of the invention is thereby intended, and alterations and modifications in the illustrated device and method, and further applications of the principles of the invention as illustrated therein are herein contemplated as would normally occur to one skilled in the art to which the invention relates.

One example of the invention is set forth in FIGS. 1-7 as system 20. System 20 includes body member 22. It has a left side 24, a right side 26, a front side 28 and a rear side 30.

One or more frame members are provided, such as central frame member 50, right frame 52 and left frame 54. Preferably, each of these frame members partially or completely encloses a central viewable region, such as viewable region 56 through which printed media may be seen. Such printable media is illustrated in FIG. 1 as "MAP" "AD" for printable media 60, 62 and 64. In the preferred version, each of the printed media has a top side 66 and an opposite side opposite thereto facing downwardly towards body member 22. Preferably, such printed media is protected by a clear plastic film, at least several mills in thickness. Moreover, preferably the imagery is reverse printed in the bottom side of such film. For example, the map lines, trees, and so forth would be reverse printed on the bottom side, and often times printed with the backing color (e.g. white ink). In this way, when the film is mounted between frame 50 and body member 22, the top surface 66 which typically is exposed through viewable region 56 protects the printed ink from scuffing, wear and the like. As illustrated, one approach is to have the three frames, left frame, right frame and central frame. It may be preferable to have a map in the central region showing steep paths and terrain, with advertisements in the other frames. Such advertisements may be sold or leased as a revenue source. Naturally, other combinations may be used, including advertisements in the middle and maps on either side, all advertisements, all maps,

or other printed media. It is possible, although not preferred, to have permanently installed printed media. However, it is preferred to have the interchangeable media, sheet 60, 62, and 64, held between the frames and the body member. In this way, the printed media may be changed from time to time by the operator.

5 Optionally, the printed media, such as sheet 60, may have holes cut therein such as hole opening 68 through which tab 58, which was downwardly projecting, projects. Preferably, such tab may be equipped with a latch tab which snaps into place in a corresponding opening in body member 22 to hold frame 50 in place. As illustrated in FIG. 1, plurality of tabs, with and without tabs may be provided
10 with corresponding openings punched or otherwise formed in the sheet 60 and other sheets. Such tabs provide registry and maintain the printed media flat, and smooth along the top surface 32 of the body member. Preferably, one or more fasteners, such as screws (not shown) are screwed through holes, such as hole 27 (see FIG. 1) located in the perimeter flange of body member 22. Such screws are
15 screwed upwardly into the corresponding frame member to help hold it in place. In the preferred embodiment, the outside frame members may be held in place by only two screws due to the hook coupling in the opposite inboard end of frame 52, said hook being shown at 29 (see FIG. 1).

 Optionally, body member 22 may include one or more recesses, such as
20 recess 34, molded therein. Such recesses provide dimensionally stiffness in body member 22 as well as providing a bottom surface on which to mount loop member 34, loop member 36 and loop member 38 (see FIG. 5) as well as other loop members as shown. Such loop members preferably are formed from metal strips wrapped in a loop which goes around the lateral cross restraint bar of the ski-lift
25 chair. Loops preferably have a top flange and bottom flange projecting tangentially from the circle formed by the loop with the tangent tabs having aligned holes drilled therein. The aligned holes received a screw through both of the holes. The screw holds the loop, such as loop 34, in place and the screw secures into the molded plastic forming body member 22. For example, one of the
30 screws holding a loop member in place shown in FIG. 5 is screwed into molded recess 34 of the body member. Preferably, the body member is molded with twin

holes on forward side and rearward side of the alignment of the loops. In this way, as illustrated by the staggering position of loop members 36, 37 and 38, the loop members may be oriented with three or more of them such that the flanges and screws holding the loop member in place are offset with each other, forward and reverse or other opposite directions. In this way, the screw holes are in a non-linear arrangement, providing a more stable and secure base to mount the system to the lateral crossbar restraint of the chair lift. As the screws are tightened down, the flanges are urged together, cinching the loop members tightly around the crossbar, gripping it tightly and preventing it from rotating with respect to the crossbar.

Preferably, system 20 has an ornamental appearance which is also aerodynamic. In this regard, one aspect of this is that the length "L" (see FIG. 4) is greater than the thickness "T" of system 20, and preferably is at least two times, and preferably three times greater than thickness "T". Moreover, top surface 32 is preferably convex along the direction of the length from front 28 to rear 30. As illustrated in FIG. 4, semi-cylindrical recess 40 runs along the entire width of system 20 so as to receive the lateral restraint crossbar therein. Note that as shown in FIG. 4, the metal holding clamps looped around the crossbar are removed. As illustrated in FIGS. 2 and 5, the front or leading edge 28 faces forwardly with respect to the ski-lift chair and is swept rearwardly along the width of the leading edge from a central region thereof (i.e. the central 1/3 thereof) to the left and the right sides of body member 22. The extreme right and left tips are rounded when viewed from a plan view.

While the invention has been illustrated and described in detail in the drawings and foregoing description, the same is to be considered as illustrative and not restrictive in character, it being understood that only the preferred embodiment has been shown and described and that all changes and modifications that come within the spirit of the invention are desired to be protected.

What is claimed is:

1. A media display system attachable to a lateral restraint along the front side of a ski-lift chair, comprising:

5 A body member attachable to the lateral restraint of the ski-lift chair, said body member having a width running generally parallel to the restraint of the ski-lift chair, a vertical thickness, and a length oriented from front to back with respect to the chair and oriented transverse to said width and said thickness, wherein said length measured in a central one-third of said width is at least two times greater
10 than the corresponding thickness; and,

A frame member located on top of said body member, said frame member having a viewable region therein, said frame member being adapted for holding printed media therein.

2. The system of claim 1 wherein said body member is not rotatable
15 with respect to the lateral restraint of the ski-lift chair.

3. The system of claim 2 wherein said body member has a leading edge facing forwardly with respect to the ski-lift chair, wherein said leading edge is swept rearwardly along said width from a central region thereof to both left and right sides of said body member.

20 4. The system of claim 3 wherein said body member and said frame collectively define a top surface which is convex along said length.

5. The system of claim 4 and further comprising a printed sheet held between said frame and said body member, said printed sheet comprising a transparent plastic sheet having imagery reverse printed on a bottom side thereof
25 facing said body member.

6. The system of claim 5 wherein said body portion has at least three tightenable metal loops on a bottom side thereof to mount around the lateral restraint, said loops each having respective flange members projecting therefrom in generally opposite forward and rearward directions and secured to said body
30 member in a non-linear arrangement.

7. The system of claim 6 wherein said frame has a plurality of tabs projecting downwardly, and wherein said sheet has openings corresponding to said tabs, said tabs projecting through said openings to aid holding said sheet in position in said frame.

5 8. The system of claim 7 and further comprising at least three frame members located on top of said body member, including a left, right and central frame member, each of said frame members having a viewable region therein, each of said frame member being adapted for holding physically separate printed media therein allowing interchange of a least one printed media without having to replace
10 another.

9. The system of claim 1 wherein said body member has a leading edge facing forwardly with respect to the ski-lift chair, wherein said leading edge is swept rearwardly along said width from a central region thereof to both left and right sides of said body member.

15 10. The system of claim 1 wherein said body member and said frame collectively define a top surface which is convex along said length.

11. The system of claim 1 and further comprising a printed sheet held between said frame and said body member, said printed sheet comprising a transparent plastic sheet having imagery reverse printed on a bottom side thereof
20 facing said body member.

12. The system of claim 1 wherein said body portion has at least three tightenable metal loops on a bottom side thereof to mount around the lateral restraint, said loops each having respective flange members projecting therefrom in forward and rearward directions and secured to said body member in a non-linear
25 arrangement.

13. The system of claim 1 wherein said frame has a plurality of tabs projecting downwardly, and wherein said printed media has openings corresponding to said tabs, said tabs projecting through said openings to aid holding said printed media in position in said frame.

30 14. The system of claim 1 and further comprising at least three frame members located on top of said body member, including a left, right and central

frame member, each of said frame members having a viewable region therein, each of said frame member being adapted for holding physically separate printed media therein allowing interchange of a least one printed media without having to replace another.

5 15. A media display system attachable to a lateral restraint along the front side of a ski-lift chair, comprising:

 A body member attachable to the lateral restraint of the ski-lift chair, said body member having a width running generally parallel to the restraint of the ski-lift chair, a vertical thickness, and a length oriented from front to back with respect
10 to the chair and oriented transverse to said width and said thickness, wherein said body member has a leading edge facing forwardly with respect to the ski-lift chair, wherein said leading edge is swept rearwardly along said width from a central region thereof to both left and right sides of said body member; and,

 a member located on said body member, said member having a viewable
15 region, said member being adapted for holding printed media therein.

 16. The system of claim 15 wherein said body portion has at least three
tightenable metal loops on a bottom side thereof to mount around the lateral
restraint, said loops each having respective flange members projecting therefrom in
forward and rearward directions and secured to said body member in a non-linear
20 arrangement.

 17. The system of claim 15 wherein said body member is not rotatable
with respect to the lateral restraint of the ski-lift chair.

 18. The system of claim 15 wherein said body member and said frame
collectively define a top surface which is convex along said length.

25 19. The system of claim 15 and further comprising a printed sheet held
between said frame and said body member, said printed sheet comprising a
transparent plastic sheet having imagery reverse printed on a bottom side thereof
facing said body member.

20. The system of claim 15 wherein said body portion has at least three
tightenable metal loops on a bottom side thereof to mount around the lateral
restraint, said loops each having respective flange members projecting therefrom in
5 generally opposite forward and rearward directions and secured to said body
member in a non-linear arrangement.

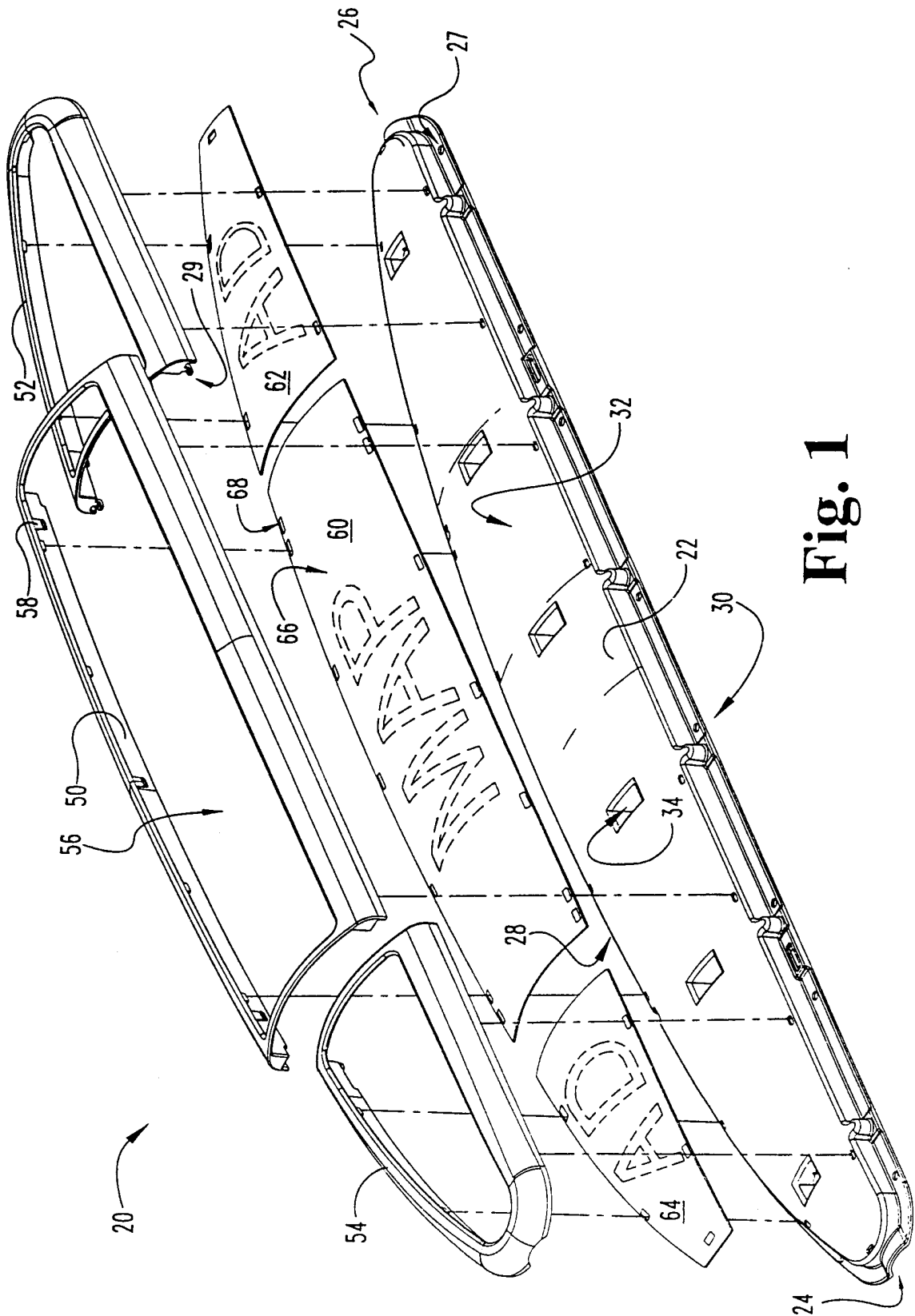

Fig. 1

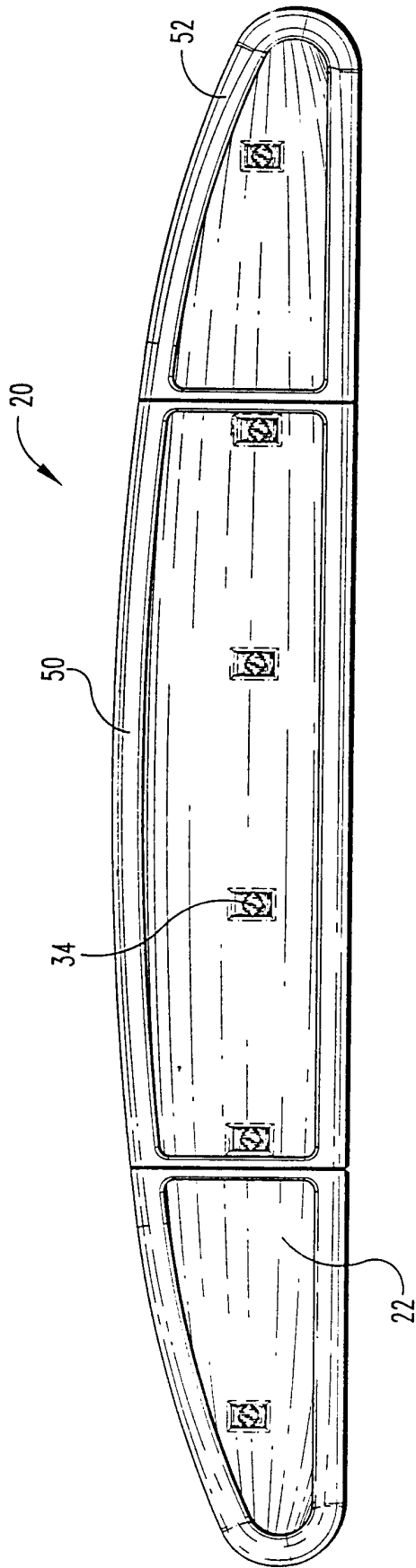

Fig. 2

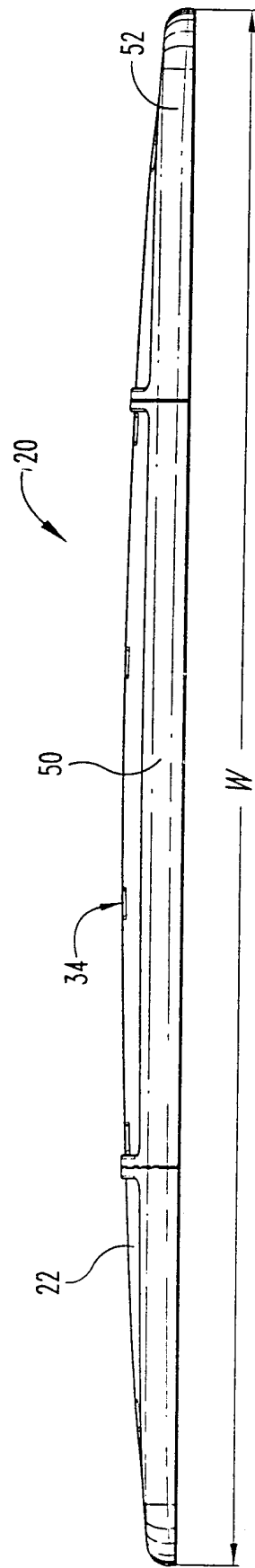

Fig. 3

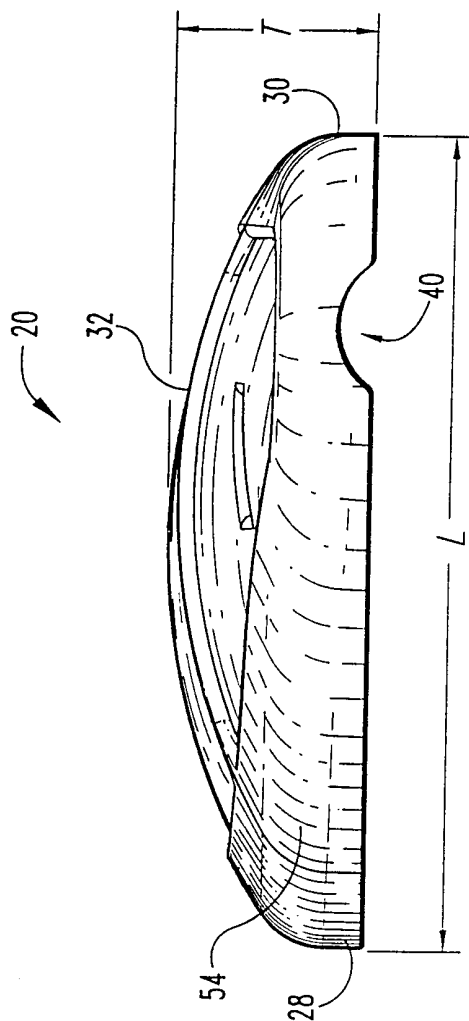

Fig. 4

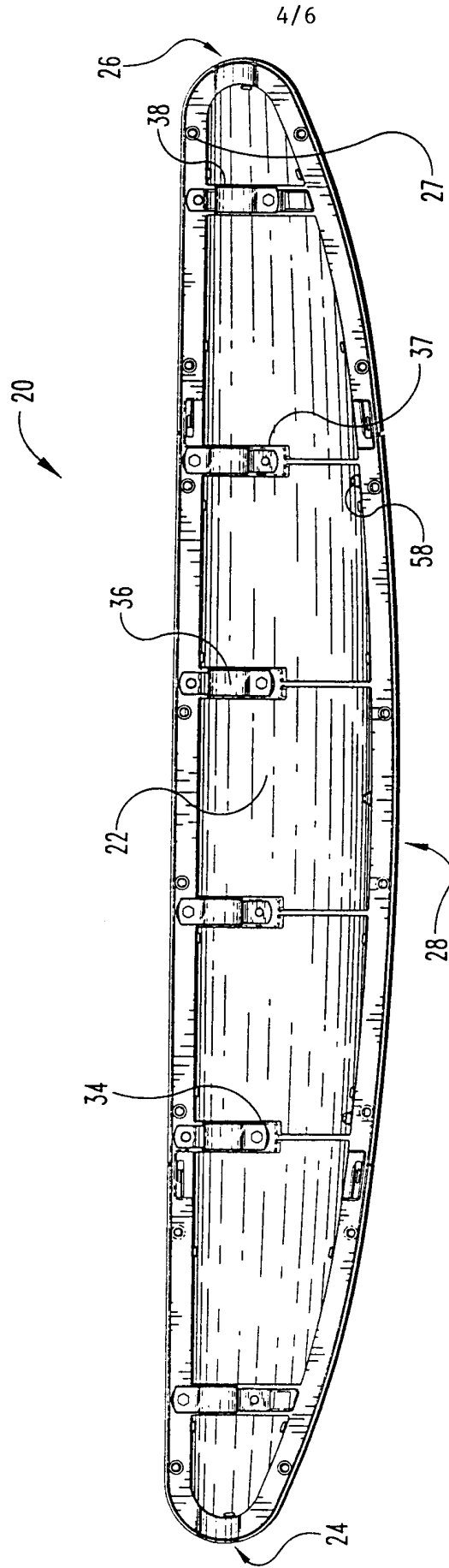

Fig. 5

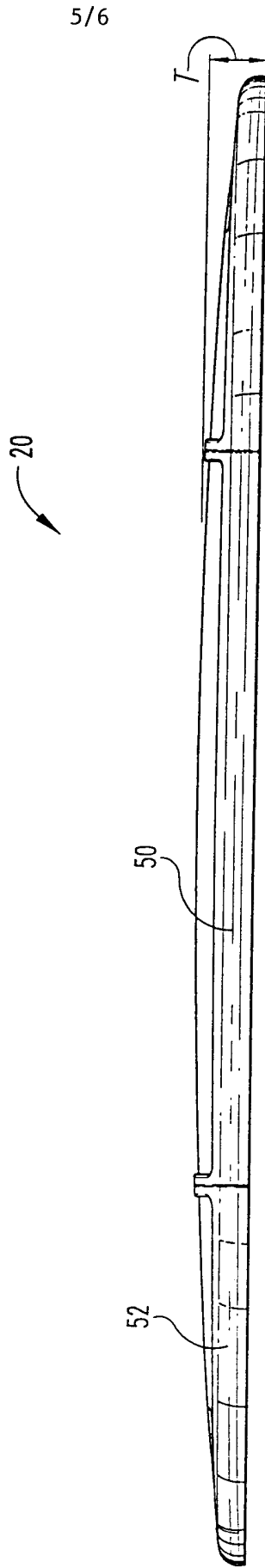

Fig. 6

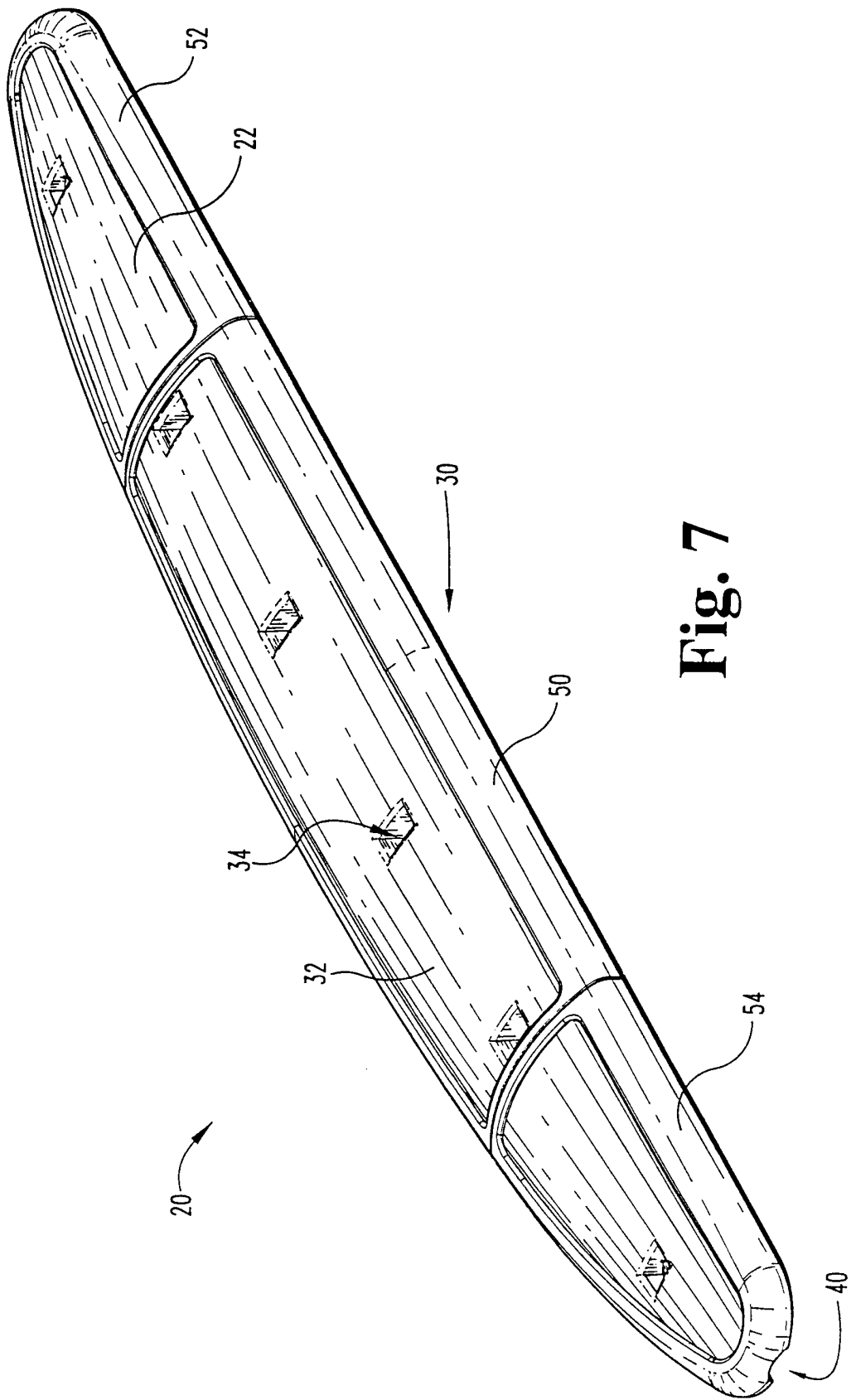

Fig. 7