

J. S. TUTTLE.
 BALING PRESS.
 APPLICATION FILED MAR. 18, 1909.

945,876.

Patented Jan. 11, 1910.

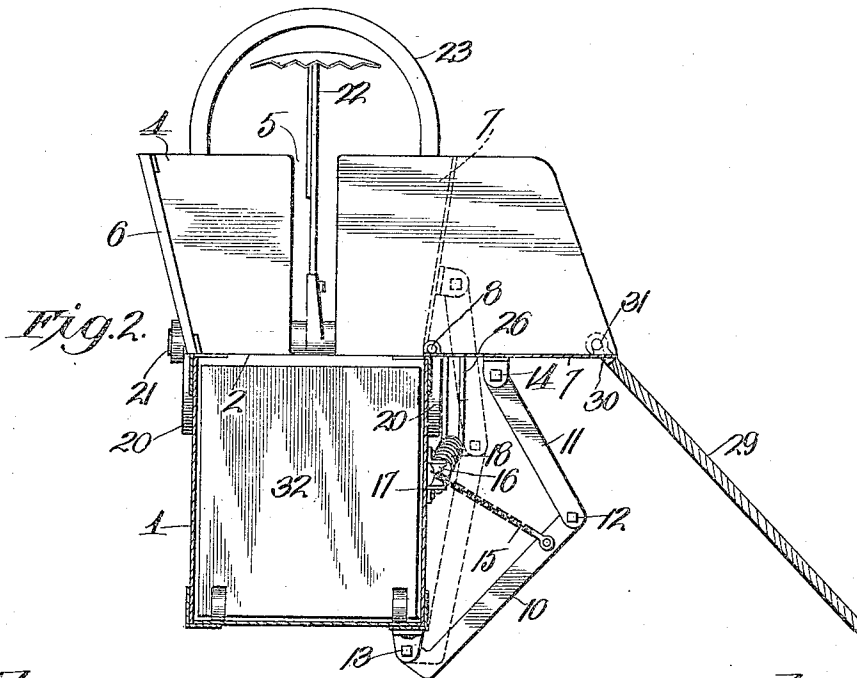
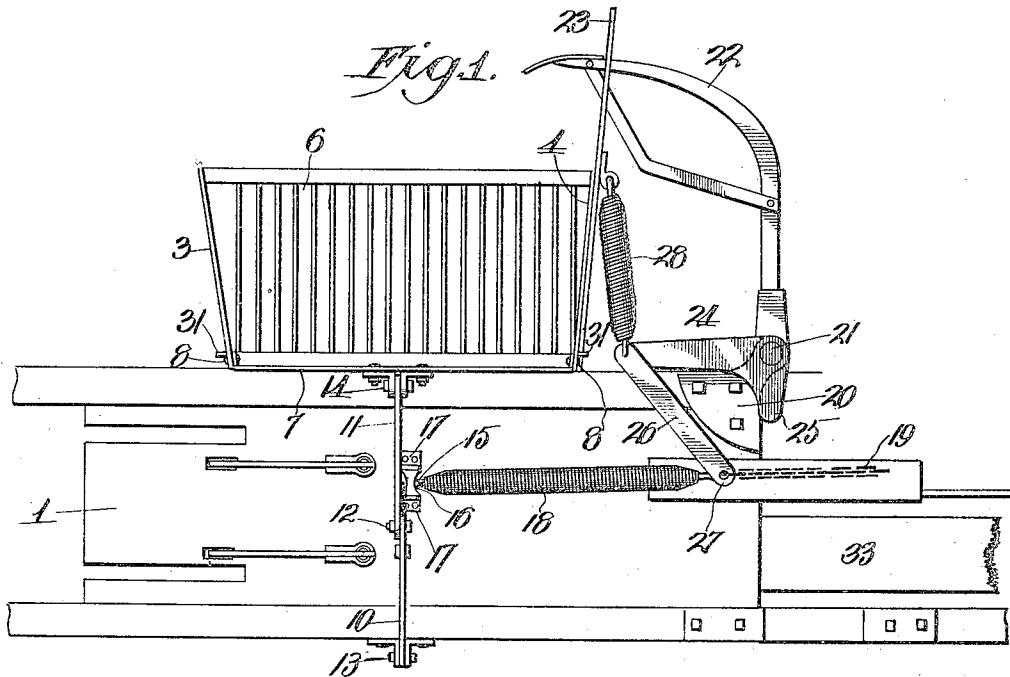

Witnesses
 Frank R. Glor
 H. C. Rodgers.

Inventor
 J. S. Tuttle
 By George F. Sharp, Atty.

UNITED STATES PATENT OFFICE.

JOSIAH S. TUTTLE, OF KANSAS CITY, MISSOURI, ASSIGNOR OF ONE-HALF TO TUTTLE HAY PRESS CO., OF KANSAS CITY, MISSOURI, A CORPORATION OF MISSOURI, AND ONE-HALF TO GEORGE ERTEL CO., OF QUINCY, ILLINOIS, A CORPORATION OF ILLINOIS.

BALING-PRESS.

945,876.

Specification of Letters Patent. Patented Jan. 11, 1910.

Application filed March 18, 1909. Serial No. 484,080.

To all whom it may concern:

Be it known that I, JOSIAH S. TUTTLE, a citizen of the United States, residing at Kansas City, in the county of Jackson and State of Missouri, have invented certain new and useful Improvements in Baling-Presses, of which the following is a specification.

This invention relates to baling presses, and has for its object to produce a machine of this character which can be easily and effectively fed by a single attendant.

A further object is to produce means for automatically effecting successively the condensation of a charge of baling material in the hopper and the forcing of such charge down into the baling chamber.

With these objects in view, the invention consists in certain novel and peculiar features of construction and organization as hereinafter described and claimed; and in order that it may be fully understood reference is to be had to the accompanying drawing, in which;—

Figure 1, is a side elevation of a part of a baling press equipped with my improvements. Fig. 2, is a side view of the same and also shows an inclined feed-board, omitted from Fig. 1.

In the said drawing, where like reference characters identify corresponding parts, 1 indicates a baling case having a feed-opening 2 in its upper side and provided with a hopper communicating with said opening, said hopper comprising a front end-wall 3 and a rear end-wall 4 projecting from one side of the baling-case beyond the other side, the rear end-wall having a vertical slot 5, for a purpose which hereinafter appears. At the ends of the side-walls terminating in substantially the same vertical plane as one side of the baling-case, is a preferably vertically slotted end-wall 6, of the hopper, the opposite wall 7 being pivoted to the walls 3 and 4 as at 8, so that it shall be capable of alternately performing the functions of a table when horizontal as shown in full lines and as a wall when substantially vertical, as shown in dotted lines, and for the purpose of overcoming the gravitative resistance of wall 7 and swinging it to its vertical position, I provide a toggle consisting of a pair of links 10 and 11 pivoted together at 12 and at their opposite ends at 13 and 14 respec-

tively, to the case and said wall. To expand said toggle, a chain 15, guided around a grooved guide-sheave 16, journaled in brackets 17 secured to the case, is secured at its front end to the toggle and at its rear end to a stiff retractile spring 18 connected by a chain 19 to the power mechanism, not shown, because of common and well-known construction, the spring 18 being of such resisting power that it is capable of effecting the elevation or condensing operation of wall 7 without any material stretching or elongation.

Journaled in bearing-brackets 20 secured to the rear upper corners of the case is a shaft 21 equipped with a feeder 22 adapted to play vertically through slot 5 of wall 4 and the inverted U-shaped frame 23 which stiffens and strengthens said wall, and said shaft is provided at one end with a crank-arm 24 having a depending heel 25. 26 is a link pivotally connecting said crank with the front end of chain 19, said link being preferably a double link having a connecting pin 27 at its lower or rear end for abutment at times against heel 25, and 28 is a retractile spring pivotally connecting the front ends of crank 24 and link 26 with the contiguous side of frame 23, for the purpose of raising the feeder to permit the hopper to be charged.

In order that a single attendant may conveniently charge the hopper, I provide a detachable feed-board 29 to be arranged in an inclined position with its lower or outer end resting on the ground adjacent to the supply of baling material (not shown) and its upper end underlying and forming a support for the outer end of wall 7 when the same is depressed, the said inclined feed-board having hooks 30 to detachably engage pins 31 projecting outwardly from the end walls 3 and 4,—only one of said hooks appearing.

Assuming that the power mechanism is in operation and imparting reciprocatory movement to the plunger 32 through the instrumentality of plunger-beam 33, and that the chain 19 is alternately drawn rearward to effect the depression of the feeder and released to permit of its reëlevation by spring 28, it will be seen that the initial portion of each rearward movement of chain 19 results

through the connections between the same and the toggle, in the quick elevation of wall 7, and the incidental engagement of pin 27 with heel 25, the movement of said wall resulting in the condensation of the hopper below the feeder of the hay or other baling material which has been fed into the hopper by the operator forking it and dragging or sweeping it with his fork upward on the feed-board and upon the wall 7, while depressed. By the time the baling material is condensed the slack is taken out of chain 19 and the continued pull on the latter stretches spring 18 and spring 28 and effects the downward or feeding stroke of the feeder, and forces the baling material condensed in the hopper, down into the baling chamber in the path of the plunger, the spring 18 being provided simply as a means for establishing a permanent connection between chains 15 and 19 which will yield so as not to interfere with the continued movement of chain 19 after that of chain 15 and wall 7 has terminated, said spring 18 as hereinbefore explained, being sufficiently stiff to not only overcome the inertia of the toggle and wall 7 and effect the expansion of the former and the elevation of the latter but also in addition thereto, to raise what baling material may be lying upon said wall and force it over the feed-opening. The engagement of the pin 27 forming the lower end of link 26, with heel 25 gives a downward pull and therefore proper leverage on crank 24 to start the feeder on its downward or feeding stroke, it being obvious that unless said heel is provided, link 26 would swing to an approximately parallel relation to the crank-arm and hence offer a resistance to the operation of the power mechanism so great as to endanger the connections between the latter and the link. It will thus be seen that the baling material is automatically condensed in the hopper and forced down into the baling chamber and that the chain 19 does not have to overcome the resistance of the condensing and feeding mechanisms at the same time. After chain 19 is released in the usual manner, springs 18 and 28 and the feeder are raised, and by this action chain 19 is slackened sufficiently to permit the pivoted wall 7 and the toggle to gravitate back to their original positions. When the baling operation is completed and the machine, is to be moved, feed-board 29 is detached and fastened upon the machine in any suitable manner, and wall 7 is secured in its elevated position in any suitable manner. The machine is then remounted upon its carrying wheels, not shown, or, if said wheels have been occupying trenches while the baling operation was in progress to avoid the necessity of removing the body from the

wheels, as is frequently resorted to, the machine is drawn out of the trenches. 65

From the above description it will be apparent that I have produced a baling press embodying the features enumerated as desirable and in addition thereto the advantages of simplicity, strength, durability and cheapness of construction, and I wish it to be understood that I reserve the right to make such changes in the form proportion, detail construction and arrangement of the parts as properly fall within the spirit and scope of the appended claims. 75

Having thus described the invention what I claim as new and desire to secure by Letters-Patent, is;

1. A baling press, comprising a baling-case having a feed-opening, a hopper communicating with the feed-opening and embodying a side wall capable of assuming substantially horizontal and vertical positions, a toggle connection between the case and the movable wall of the hopper, means for expanding the toggle and raising said wall, a spring-elevated feeder to swing down and upward in the hopper and baling-chamber, a crank rotatable with said feeder, a flexible connection suitably guided attached at one end to the toggle, a link pivotally attached to said crank, a retractile spring between the opposite end of said flexible link, and means to impart longitudinal movement to said spring and forward and downward movement to said link. 80 85 90 95

2. A baling press, comprising a baling case having a feed opening, a hopper communicating with the feed opening and embodying a side wall capable of assuming substantially horizontal and vertical positions, a toggle-connection between the case and the movable wall of the hopper, a guide sheave secured to the baling case, a feeder pivoted to the baling case and adapted to swing down into and out of the baling case through the hopper, yielding means holding the feeder normally elevated, a crank arm rotatable with the feeder, a link pivoted to the crank arm, a retractile spring connected to the link, a flexible connection trained around said guide sheave and attached at its opposite ends to the toggle and said retractile spring, and a flexible connection attached to said link and adapted when moved forward to effect upward movement of the said movable wall and downward movement of the feeder. 100 105 110 115

In testimony whereof I affix my signature in presence of two witnesses. 120

JOSIAH S. TUTTLE.

Witnesses:

H. C. RODGERS,
G. Y. THORPE.