



- (51) International Patent Classification: *H01H 47/00* (2006.01) [US/US]; 989 112th Avenue NE #2310, Bellevue, WA 98004 (US).
- (21) International Application Number: PCT/US2012/044951
- (22) International Filing Date: 29 June 2012 (29.06.2012)
- (25) Filing Language: English
- (26) Publication Language: English
- (30) Priority Data: 13/135,320 29 June 2011 (29.06.2011) US
- (71) Applicant (for all designated States except US): **ELWHA LLC** [US/US]; 11235 SE 6th Street, Suite 200, Bellevue, WA 98004 (US).
- (72) Inventors; and
- (75) Inventors/Applicants (for US only): **HYDE, Roderick, A.** [US/US]; 9915 - 161st Avenue N.E., Redmond, WA 98052 (US). **KARE, Jordin, T.** [US/US]; 908 15th Ave. East, Seattle, WA 98112 (US). **WOOD, JR., Lowell, L.**
- (74) Agents: **CHAN, Alistair, K.** et al.; 11235 SE 6th Street, Suite 200, Bellevue, WA 98004 (US).
- (81) Designated States (unless otherwise indicated, for every kind of national protection available): AE, AG, AL, AM, AO, AT, AU, AZ, BA, BB, BG, BH, BR, BW, BY, BZ, CA, CH, CL, CN, CO, CR, CU, CZ, DE, DK, DM, DO, DZ, EC, EE, EG, ES, FI, GB, GD, GE, GH, GM, GT, HN, HR, HU, ID, IL, IN, IS, JP, KE, KG, KM, KN, KP, KR, KZ, LA, LC, LK, LR, LS, LT, LU, LY, MA, MD, ME, MG, MK, MN, MW, MX, MY, MZ, NA, NG, NI, NO, NZ, OM, PE, PG, PH, PL, PT, QA, RO, RS, RU, RW, SC, SD, SE, SG, SK, SL, SM, ST, SV, SY, TH, TJ, TM, TN, TR, TT, TZ, UA, UG, US, UZ, VC, VN, ZA, ZM, ZW.
- (84) Designated States (unless otherwise indicated, for every kind of regional protection available): ARIPO (BW, GH, GM, KE, LR, LS, MW, MZ, NA, RW, SD, SL, SZ, TZ, UG, ZM, ZW), Eurasian (AM, AZ, BY, KG, KZ, RU, TJ, TM), European (AL, AT, BE, BG, CH, CY, CZ, DE, DK, EE, ES, FI, FR, GB, GR, HR, HU, IE, IS, IT, LT, LU, LV,

[Continued on next page]

(54) Title: SYSTEMS AND METHODS FOR CONTROLLED STARTUP OF ELECTRICAL DEVICES LOADING A POWER LINE

FIG. 4

400

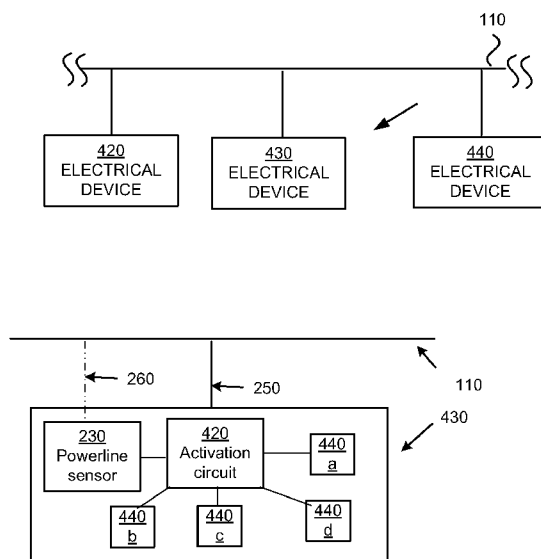

(57) Abstract: An electrical system having a plurality of devices is supplied with power by a common power supply line. One of the devices has a circuit that slows or delays device startup or activation in response to a signal indicative of power demand, draw or use by another of the plurality of devices supplied with power by the common power supply line.

WO 2013/003732 A1

MC, MK, MT, NL, NO, PL, PT, RO, RS, SE, SI, SK, **Published:**
SM, TR), OAPI (BF, BJ, CF, CG, CI, CM, GA, GN, GQ, — *with international search report (Art. 21(3))*
GW, ML, MR, NE, SN, TD, TG).

SYSTEMS AND METHODS FOR CONTROLLED STARTUP OF ELECTRICAL DEVICES LOADING A POWER LINE

5

**Inventor(s):
Roderick A. Hyde; Jordin T. Kare; and Lowell L. Wood, Jr.**

BACKGROUND

The present application relates, in general, to power management. In particular, the application relates to controlling power draw by electronic and/or electrical devices from a power line or grid.

Power usage by an electronic or electrical device (e.g., an electrical motor, a computer, a fluorescent lamp etc.) generally varies with the operational mode or state of the device. For example, the electrical or electronic device (hereinafter collectively “electronic device”) may have a higher power demand or consumption in startup mode than during steady state operation. The device may exhibit a peak level of power consumption in the startup mode. The device may also exhibit a similar peak level of power consumption in shutdown mode. The peak power demand placed by the device on the power line may be significantly greater than the operational steady-state power demand. The power line or grid may be overdesigned to have a supply capacity sufficient to accommodate the peak power demand of the device (which typically may be substantially greater than the operational steady-state power load). However, when a plurality of devices (e.g., in industrial or household settings) are powered by the same

power line or grid, concurrent peak loading by the devices may exceed the supply capacity of the power line of grid and lead to device and/or system failures.

Consideration is now being given to managing power demands or loads placed on a supply power line or grid. In particular, consideration is now being given to solutions
5 for controlling startup or other modes of operation of devices to regulate power demands placed on supply power line or grid. Some such solutions may allow power demand/consumption by the devices to be staggered so that the total power demand does not exceed the instantaneous supply capacity of the power line or grid.

SUMMARY

10 Approaches to managing power draw by a plurality of electrical/electronic devices coupled to a power line or grid are provided.

In one approach, an electrical device includes a device startup or activation circuit. A power line sensor is coupled to the device startup or activation circuit. The power line sensor is configured to dynamically sense properties of a power supply line for the device.
15 The device startup or activation circuit is configured to slow or delay device startup or activation when the power line sensor senses a voltage drop on the power supply line.

In another approach, an electrical system includes a plurality of electrical devices coupled to a power supply line. A first of the electrical devices has a signal-generating circuit that generates a signal indicative of power demand or use by the first device. A
20 second of the electrical devices coupled to the power supply line includes an activation or startup circuit, which is directly responsive to the generated signal indicative of power demand or use by the first device. The activation or startup circuit regulates or controls power use by the second device according to the signal indicative of power demand or use

by the first device. The signal-generating circuit may, for example, emit a signal when the power demand or use by the first device exceeds a threshold value. In response, the activation or startup circuit may prevent or delay startup or activation of the second device. Additionally or alternatively, the activation or startup circuit may prevent or
5 delay operation of the second device in a high-power mode while the signal indicative of power demand or use by the first device is at or above the threshold value.

BRIEF DESCRIPTION OF THE FIGURES

In the accompanying drawings:

FIG. 1 is schematic illustration of a plurality of electrical/electronic devices
10 connected to a power supply line;

FIG. 2 is a block diagram illustrating components of an exemplary electrical device, in accordance with the principles of the solutions described herein;

FIG. 3 is a flow diagram illustrating an exemplary method for controlled startup or activation of an electrical device connected to a power supply line;

15 FIG. 4 is a schematic illustration of an exemplary electrical system having controlled device-startup and activation features for an electrical device therein, in accordance with the principles of the solutions described herein;

FIG. 5 is a block diagram illustrating exemplary devices that can be deployed in the electrical system of FIG. 4, in accordance with the principles of the solutions described
20 herein; and,

FIG. 6 is a flow diagram illustrating an exemplary method for regulating or controlling power use by a device in an electrical system having a plurality of electrical

devices coupled to a power supply line, in accordance with the principles of the solutions described herein;

Throughout the figures, unless otherwise stated, the same reference numerals and characters are used to denote like features, elements, components, or portions of the
5 illustrated embodiments.

DESCRIPTION

In the following description of exemplary embodiments, reference is made to the accompanying drawings, which form a part hereof. It will be understood that
embodiments described herein are exemplary, but are not meant to be limiting. Further, it
10 will be appreciated that the solutions described herein can be practiced or implemented by other than the described embodiments. Modified embodiments or alternate embodiments may be utilized, in the spirit and scope of the solutions described herein.

FIG. 1 shows a plurality of electrical or electronic devices (e.g., devices 120, 130, and 140) that are supplied with power by an exemplary power transmission line 110.
15 Power line 110 may, for example, be a distribution line or feeder line in an electricity transmission grid delivering power to local users from a power-generating plant at a remote location. The devices may for example, be any type of electrical or electronic device. The devices may be any of a variety of industrial and/or household devices (e.g. electric motors, industrial fans, blowers and pumps, machine tools, lamps, household
20 appliances, power tools, servers, computers, and disk drives, etc.). They may operate on direct current or on alternating current from a central electrical distribution grid. A device may include active and/or passive electrical components. A device may include circuits (e.g., transformers, frequency convertors, filters, etc.) that prepare or recondition power

drawn from the power line and apply it to a device component. A device may include a device startup or activation circuit. The device startup or activation circuit may, for example, include an electronic or electro-mechanical power switch that is operable by user command or instruction. The device startup or activation circuit may include subcircuits
5 for controlling operation of various components of the device.

To manage power draw or loading of power line 110, one or more of the connected devices (e.g., devices 120, 130, and 140) may include a power line sensor coupled to the device startup or activation circuit. The power line sensor may be configured to monitor one or more properties (e.g., voltage, current, phase, frequency, noise, etc) of power line
10 110. The device startup or activation circuit may in response

FIG. 2 shows an exemplary electrical device 210 configured according to the principles disclosed herein. Electrical device 210 includes a device startup or activation circuit 220, which regulates or controls power supply to active and/or passive electrical device components (e.g., 240a-240d). Device startup or activation circuit 220 is coupled
15 to a power line sensor 230. Sensor 230 may be configured to dynamically sense properties of a power supply line (e.g., power line 110) that is connected to electrical device 210. Device startup or activation circuit 220 may be configured to control or regulate startup or activation electrical device 210 (e.g., by timing or regulating operation of one or more device components 240a-240d) in response to sensed properties of the power supply line.

20 Sensor 230 may, for example, be configured to dynamically sense a voltage drop on the power supply line caused by transient high power demand by other devices (e.g., devices 130 and 140) coupled to the power supply line. Device startup or activation circuit 220 may be configured to slow or delay device startup or activation if the sensed

voltage drop on the power supplies line occurs at or about device startup or activation and/or about a peak power draw by device 210 from the power supply line.

In other or additional versions, sensor 230 may be configured to sense voltage and/or current phase on the power supply line as an indicator of high power demand by other devices coupled to the power supply line. Additionally or alternatively, sensor 230
5 may be configured to sense high frequency power components on the power supply line as an indicator of high power demand by other devices coupled to the power supply line.

Sensor 230 may be configured to sense properties of the supply power line via of any physical or electrical connection (e.g., connection 250 or 260) to the supply power
10 line. Sensor 230 may be configured to sense properties of the supply power line independent of any electrical supply connection (e.g., connection 250) to device 210. Sensor 230 may, for example, be configured to sense properties of the supply power line via wired, wireless, inductive, or capacitive link 260 even while electrical supply connection 250 is switched off. It will be understood that even though sensor 230 is
15 referred to as ‘sensor’, it may be any suitable sensing arrangement. For example, sensor 230 may merely be a receiver which receives power line information derived or measured by other external sensors.

In response to a sensed drop or dip in the voltage on the power line, device startup or activation circuit 220 may be configured to slow or delay device startup or activation
20 until the voltage on the power line recovers to a normal line voltage value or a threshold voltage value. Device startup or activation circuit 220 may include a reference a reference to the normal line voltage value or minimum threshold voltage value. The reference may,

for example, an average power supply line voltage value. The normal line voltage value is a power supply line voltage value immediately before switching on the electrical device.

FIG. 3 shows an exemplary method 300 for controlled startup or activation of an electrical device (e.g., device 120). Method 300 includes dynamically sensing properties
5 of a power supply line for the device (310); and, in response to a sensed voltage drop on the power supply line at or about device startup or activation and/or about a peak power draw by the device from the power supply line, slowing or delaying device startup or
activation (320).

In method 300, dynamically sensing properties of a power supply line (310) may
10 include, for example, a voltage drop caused by high power demand by other devices coupled to the power supply line. The properties of the supply power line may be sensed while a physical electrical connection of the supply power line to the electrical device is
switched off, for example, via other wireless or wired means. Dynamically sensing
properties of a power supply line (310) may include sensing high frequency power
15 components on the power supply line, and/or sensing voltage and/or current phase as indicators of high power demand by other devices coupled to the power supply line.

Further in method 300, slowing or delaying device startup or activation in response
to a sensed voltage drop on the power supply line may include delaying device startup or
activation until the voltage on the power line recovers to a normal line voltage value or
20 other threshold value. The delay may be initiated or controlled by referencing the voltage drop to the normal line voltage value or other threshold value (e.g., an average power
supply line voltage value, power supply line voltage value immediately before switching
on the electrical device, etc.).

FIG. 4 shows an exemplary electrical system 400 having controlled device-startup and activation features. System 400 includes a plurality of electrical devices (e.g., devices 420-440, 510-520) coupled to a common power supply line (e.g., line 110). At least a first of the electrical devices (e.g., device 510, FIG. 5) has a signal-generating circuit that
5 generates a signal indicative of power demand or use by the first device (e.g., device 510, FIG. 5). At least a second of the electrical devices (e.g., device 520, FIG. 5) includes an activation or startup circuit directly responsive to the generated signal indicative of power demand or use by the first device. The activation or startup circuit regulates or controls power use by the second device according to the signal indicative of power demand or use
10 by the first device. The activation or startup circuit in electrical system 400 may be configured to allow startup or activation or a high-power operation mode of the second device only when the signal indicative of power demand by the first device has particular values (e.g., below, at or above a threshold value).

FIG. 5 shows exemplary devices 510 and 520 that may be deployed in electrical
15 system 400. Device 510 has a signal-generating circuit 515 configured to generate a signal indicative of power demand or use by the device. Signal-generating circuit 515 may be configured to emit an indicative signal when the power demand or use by the first device exceeds a threshold value, or falls below the same or another threshold value. Device 520, which includes an activation or startup circuit 525, may include a include a
20 signal receiver 527 or other means for receiving signals indicative of power demand or use by other devices. Activation or startup circuit 525 is coupled to signal receiver 527 or the other signal receiving means. Activation or startup circuit 525 may be configured to prevent or delay startup, activation or high-power operation modes of the device while the

signal indicative of power demand or use by another device (e.g., device 510) is at or above a threshold value.

With renewed reference to FIG. 4, the signal indicative of power demand or use by the first device (e.g., device 510) may be transmitted other devices (e.g., 420-440, 520) over any suitable link. The signal may be broadcast or transmitted over electrical system 400 as an RF, ultrasonic or optical signal. Alternatively or additionally, the signal indicative of power demand or use by the first device (e.g., device 510) may be transmitted as an electrical signal modulating power supply line 110. The first device may transmit the signal indicative of power demand or use by the first device according to a collision avoidance protocol to avoid confusion as there may be other similarly configured devices in system 400 that also transmit respective signals indicative of device power demand or use over the power supply line. The collision avoidance protocol may, for example, include transmission of the signal a random time interval after a determination that no other signal indicative of power demand or use by another of the electrical devices is present or detected propagating on the power supply line. Alternatively, the collision avoidance protocol may include transmission of the signal a device-specific time interval after a determination that no other signal indicative of power demand or use by another of the electrical devices is present or detected propagating on the power supply line.

In a version of electrical system 400, one or more of the plurality of electrical devices (e.g., devices 420-440, 510-520, etc.) may be arranged to turn-on only in assigned time windows relative to turn-on of an initial one of the plurality of electrical devices or relative to an event affecting power draw from power supply line 110. Alternatively or

additionally, a multiplicity of electrical devices may be arranged to turn-on in groups in a phased manner.

FIG. 6 shows an exemplary method 600 of regulating or controlling power use by a device according to the signal indicative of power demand or use by another device in an electrical system having a plurality of electrical devices coupled to a power supply line. Method 600 includes generating a signal indicative of dynamic power demand or use by a first device (610); and, regulating or controlling power use by a second device according to the signal indicative of power demand or use by the first device (620).

In method 600, generating a signal indicative of dynamic power demand or use by the first device (610) may include generating a signal by comparing the power demand or use by the first device with respect to a reference value. For example, respective indicative signals may be generated when the power demand is at or above a first threshold value and/or falls below a second threshold value.

Generating a signal indicative of dynamic power demand or use by the first device (610) may include transmitting or broadcasting an electrical, RF, ultrasonic or optical signal. Generating a signal indicative of dynamic power demand or use by the first device (610) may include transmitting the signal as an electrical signal modulating the power supply line. The method may include transmitting the electrical signal modulating the power supply line according to a suitable collision avoidance protocol that is designed, for example, to avoid collision or interference with signals indicative of dynamic power demand or use by other devices connected to the power supply line. A suitable collision avoidance protocol may, for example, include transmission of the signal a random time interval after a determination that no other signal indicative of power demand or use by

another of the electrical devices is detected, present or propagating on the power supply line. Another suitable collision avoidance protocol may, for example, include transmission of the signal a device-specific time interval after a determination that no other signal indicative of power demand or use by another of the electrical devices is
5 detected, present or propagating on the power supply line.

In method 600, regulating or controlling power use by the second device (620) may include limiting allowing startup or activation or a high-power operation mode of the second device only when the signal indicative of power demand by the first device is below a threshold value. Alternatively or additionally, regulating or controlling power use
10 by the second device (610) may include turning off or reducing power use by the second device while the signal indicative of power demand or use by the first device is at or above a threshold value. Further, regulating or controlling power use by the second device (610) may additionally or alternatively include assigning one or more of the plurality of
15 electrical devices to turn-on only in suitably selected time windows relative to turn-on of an initial one of the plurality of electrical devices or relative to an event affecting power draw from the power supply line, and/or arranging a multiplicity of electrical devices to turn-on in groups in a phased manner.

In the foregoing detailed description, reference is made to the accompanying
20 drawings, which form a part hereof. In the drawings, similar symbols typically identify similar components, unless context dictates otherwise. The illustrative embodiments described in the summary, detailed description, drawings, and claims are not meant to be limiting. Other embodiments may be utilized, and other changes may be made, without departing from the spirit or scope of the subject matter presented here. Those having skill

in the art will recognize that the state of the art has progressed to the point where there is little distinction left between hardware and software implementations of aspects of systems; the use of hardware or software is generally (but not always, in that in certain contexts the choice between hardware and software can become significant) a design
5 choice representing cost vs. efficiency tradeoffs. Those having skill in the art will appreciate that there are various vehicles by which processes and/or systems and/or other technologies described herein can be effected (e.g., hardware, software, and/or firmware), and that the preferred vehicle will vary with the context in which the processes and/or systems and/or other technologies are deployed. For example, if an implementer
10 determines that speed and accuracy are paramount, the implementer may opt for a mainly hardware and/or firmware vehicle; alternatively, if flexibility is paramount, the implementer may opt for a mainly software implementation; or, yet again alternatively, the implementer may opt for some combination of hardware, software, and/or firmware.
Hence, there are several possible vehicles by which the processes and/or devices and/or
15 other technologies described herein may be effected, none of which is inherently superior to the other in that any vehicle to be utilized is a choice dependent upon the context in which the vehicle will be deployed and the specific concerns (e.g., speed, flexibility, or predictability) of the implementer, any of which may vary. Those skilled in the art will recognize that optical aspects of implementations will typically employ optically-oriented
20 hardware, software, and or firmware.

The foregoing detailed description has set forth various embodiments of the devices and/or processes via the use of block diagrams, flowcharts, and/or examples. Insofar as such block diagrams, flowcharts, and/or examples contain one or more functions and/or operations, it will be understood by those within the art that each function

and/or operation within such block diagrams, flowcharts, or examples can be implemented, individually and/or collectively, by a wide range of hardware, software, firmware, or virtually any combination thereof. In one embodiment, several portions of the subject matter described herein may be implemented via Application Specific

5 Integrated Circuits (ASICs), Field Programmable Gate Arrays (FPGAs), digital signal processing circuits (DSPs), or other integrated formats. However, those skilled in the art will recognize that some aspects of the embodiments disclosed herein, in whole or in part, can be equivalently implemented in integrated circuits, as one or more computer

10 programs running on one or more computers (e.g., as one or more programs running on one or more computer systems), as one or more programs running on one or more processing circuits (e.g., as one or more programs running on one or more microprocessors), as firmware, or as virtually any combination thereof, and that designing the circuitry and/or writing the code for the software and or firmware would be well within the skill of one of skill in the art in light of this disclosure. In addition, those skilled in the

15 art will appreciate that the mechanisms of the subject matter described herein are capable of being distributed as a program product in a variety of forms, and that an illustrative embodiment of the subject matter described herein applies regardless of the particular type of signal bearing medium used to actually carry out the distribution. Examples of a signal bearing medium include, but are not limited to, the following: a recordable type medium

20 such as a floppy disk, a hard disk drive, a Compact Disc (CD), a Digital Video Disk (DVD), a digital tape, a computer memory, etc.; and a transmission type medium such as a digital and/or an analog communication medium (e.g., a fiber optic cable, a waveguide, a wired communications link, a wireless communication link, etc.). Further, those skilled in

the art will recognize that the mechanical structures disclosed are exemplary structures and many other forms and materials may be employed in constructing such structures.

In a general sense, those skilled in the art will recognize that the various embodiments described herein can be implemented, individually and/or collectively, by various types of electro-mechanical systems having a wide range of electrical components such as hardware, software, firmware, or virtually any combination thereof; and a wide range of components that may impart mechanical force or motion such as rigid bodies, spring or torsional bodies, hydraulics, and electro-magnetically actuated devices, or virtually any combination thereof. Consequently, as used herein "electro-mechanical system" includes, but is not limited to, electrical circuitry operably coupled with a transducer (e.g., an actuator, a motor, a piezoelectric crystal, etc.), electrical circuitry having at least one discrete electrical circuit, electrical circuitry having at least one integrated circuit, electrical circuitry having at least one application specific integrated circuit, electrical circuitry forming a general purpose computing device configured by a computer program (e.g., a general purpose computer configured by a computer program which at least partially carries out processes and/or devices described herein, or a microprocessor configured by a computer program which at least partially carries out processes and/or devices described herein), electrical circuitry forming a memory device (e.g., forms of random access memory), electrical circuitry forming a communications device (e.g., a modem, communications switch, or optical-electrical equipment), and any non-electrical analog thereto, such as optical or other analogs. Those skilled in the art will also appreciate that examples of electro-mechanical systems include but are not limited to a variety of consumer electronics systems, as well as other systems such as motorized transport systems, factory automation systems, security systems, and

communication/computing systems. Those skilled in the art will recognize that electro-mechanical as used herein is not necessarily limited to a system that has both electrical and mechanical actuation except as context may dictate otherwise.

In a general sense, those skilled in the art will recognize that the various aspects
5 described herein which can be implemented, individually and/or collectively, by a wide
range of hardware, software, firmware, or any combination thereof can be viewed as being
composed of various types of "electrical circuitry." Consequently, as used herein
"electrical circuitry" includes, but is not limited to, electrical circuitry having at least one
discrete electrical circuit, electrical circuitry having at least one integrated circuit,
10 electrical circuitry having at least one application specific integrated circuit, electrical
circuitry forming a general purpose computing device configured by a computer program
(e.g., a general purpose computer configured by a computer program which at least
partially carries out processes and/or devices described herein, or a microprocessor
configured by a computer program which at least partially carries out processes and/or
15 devices described herein), electrical circuitry forming a memory device (e.g., forms of
random access memory), and/or electrical circuitry forming a communications device
(e.g., a modem, communications switch, or optical-electrical equipment). Those having
skill in the art will recognize that the subject matter described herein may be implemented
in an analog or digital fashion or some combination thereof.

20 Those skilled in the art will recognize that it is common within the art to
implement devices and/or processes and/or systems in the fashion(s) set forth herein, and
thereafter use engineering and/or business practices to integrate such implemented devices
and/or processes and/or systems into more comprehensive devices and/or processes and/or

systems. That is, at least a portion of the devices and/or processes and/or systems described herein can be integrated into other devices and/or processes and/or systems via a reasonable amount of experimentation. Those having skill in the art will recognize that examples of such other devices and/or processes and/or systems might include – as
5 appropriate to context and application -- all or part of devices and/or processes and/or systems for generation, transmission and distribution of electrical power, a communications system (e.g., a networked system, a telephone system, a Voice over IP system, wired/wireless services, etc.).

One skilled in the art will recognize that the herein described components (e.g.,
10 steps), devices, and objects and the discussion accompanying them are used as examples for the sake of conceptual clarity and that various configuration modifications are within the skill of those in the art. Consequently, as used herein, the specific exemplars set forth and the accompanying discussion are intended to be representative of their more general classes. In general, use of any specific exemplar herein is also intended to be
15 representative of its class, and the non-inclusion of such specific components (e.g., steps), devices, and objects herein should not be taken as indicating that limitation is desired.

With respect to the use of substantially any plural and/or singular terms herein, those having skill in the art can translate from the plural to the singular and/or from the singular to the plural as is appropriate to the context and/or application. The various
20 singular/plural permutations are not expressly set forth herein for sake of clarity.

The herein described subject matter sometimes illustrates different components contained within, or connected with, different other components. It is to be understood that such depicted architectures are merely exemplary, and that in fact many other

architectures can be implemented which achieve the same functionality. In a conceptual sense, any arrangement of components to achieve the same functionality is effectively "associated" such that the desired functionality is achieved. Hence, any two components herein combined to achieve a particular functionality can be seen as "associated with" each other such that the desired functionality is achieved, irrespective of architectures or intermedial components. Likewise, any two components so associated can also be viewed as being "operably connected", or "operably coupled", to each other to achieve the desired functionality, and any two components capable of being so associated can also be viewed as being "operably couplable", to each other to achieve the desired functionality. Specific examples of operably couplable include but are not limited to physically mateable and/or physically interacting components and/or wirelessly interactable and/or wirelessly interacting components and/or logically interacting and/or logically interactable components.

While particular aspects of the present subject matter described herein have been shown and described, it will be apparent to those skilled in the art that, based upon the teachings herein, changes and modifications may be made without departing from the subject matter described herein and its broader aspects and, therefore, the appended claims are to encompass within their scope all such changes and modifications as are within the true spirit and scope of the subject matter described herein. Furthermore, it is to be understood that the invention is defined by the appended claims. It will be understood by those within the art that, in general, terms used herein, and especially in the appended claims (e.g., bodies of the appended claims) are generally intended as "open" terms (e.g., the term "including" should be interpreted as "including but not limited to," the term "having" should be interpreted as "having at least," the term "includes" should be

interpreted as “includes but is not limited to,” etc.). It will be further understood by those within the art that if a specific number of an introduced claim recitation is intended, such an intent will be explicitly recited in the claim, and in the absence of such recitation no such intent is present. For example, as an aid to understanding, the following appended

5 claims may contain usage of the introductory phrases "at least one" and "one or more" to introduce claim recitations. However, the use of such phrases should not be construed to imply that the introduction of a claim recitation by the indefinite articles "a" or "an" limits any particular claim containing such introduced claim recitation to inventions containing only one such recitation, even when the same claim includes the introductory phrases "one

10 or more" or "at least one" and indefinite articles such as "a" or "an" (e.g., “a” and/or “an” should typically be interpreted to mean “at least one” or “one or more”); the same holds true for the use of definite articles used to introduce claim recitations. In addition, even if a specific number of an introduced claim recitation is explicitly recited, those skilled in the art will recognize that such recitation should typically be interpreted to mean at least the

15 recited number (e.g., the bare recitation of "two recitations," without other modifiers, typically means at least two recitations, or two or more recitations). Furthermore, in those instances where a convention analogous to “at least one of A, B, and C, etc.” is used, in general such a construction is intended in the sense one having skill in the art would understand the convention (e.g., “ a system having at least one of A, B, and C” would

20 include but not be limited to systems that have A alone, B alone, C alone, A and B together, A and C together, B and C together, and/or A, B, and C together, etc.). In those instances where a convention analogous to “at least one of A, B, or C, etc.” is used, in general such a construction is intended in the sense one having skill in the art would understand the convention (e.g., “ a system having at least one of A, B, or C” would

include but not be limited to systems that have A alone, B alone, C alone, A and B together, A and C together, B and C together, and/or A, B, and C together, etc.). It will be further understood by those within the art that virtually any disjunctive word and/or phrase presenting two or more alternative terms, whether in the description, claims, or drawings, 5 should be understood to contemplate the possibilities of including one of the terms, either of the terms, or both terms. For example, the phrase “A or B” will be understood to include the possibilities of “A” or “B” or “A and B.”

CLAIMS

1. An electrical device, the device comprising:
 - a device startup or activation circuit; and
 - a power line sensor coupled to the device startup or activation circuit,
- 5 wherein the power line sensor is configured to dynamically sense properties of a power supply line for the device, and wherein the device startup or activation circuit is configured to slow or delay device startup or activation upon a sensed voltage drop on the power supply line at or about device startup or activation and/or about a peak power draw by the device from the power supply line.
- 10 2. The electrical device of claim 1, wherein the power line sensor is configured to sense a voltage drop on the power supply line caused by transient high power demand by other devices coupled to the power supply line.
3. The electrical device of claim 1, wherein the power line sensor is configured to sense voltage and/or current phase on the power supply line as an indicator of high power
- 15 demand by other devices coupled to the power supply line.
4. The electrical device of claim 1, wherein the power line sensor is configured to sense high frequency power components on the power supply line as an indicator of high power demand by other devices coupled to the power supply line.
5. The electrical device of claim 1, wherein the power line sensor is configured to sense
- 20 properties of the supply power line while a connection of the supply power line to the electrical device is switched off.
6. The electrical device of claim 1, wherein the device startup or activation circuit is configured to delay device startup or activation until the voltage on the power line recovers to a normal line voltage value.
- 25 7. The electrical device of claim 6, wherein the device startup or activation circuit includes a reference to the normal line voltage value.

8. The electrical device of claim 6, wherein the normal line voltage value is an average power supply line voltage value.
9. The electrical device of claim 6, wherein the normal line voltage value is a power supply line voltage value immediately before switching on the electrical device.
- 5 10. A method for controlled startup or activation of an electrical device, the method comprising:

dynamically sensing properties of a power supply line for the device; and

slowing or delaying device startup or activation in response to a sensed voltage drop on the power supply line at or about device startup or activation and/or about a peak power
10 draw by the device from the power supply line.
11. The method of claim 10, wherein dynamically sensing properties of a power supply line comprises sensing a voltage drop on the power supply line caused by transient high power demand by other devices coupled to the power supply line.
12. The method of claim 10, wherein dynamically sensing properties of a power supply
15 line comprises sensing high frequency power components on the power supply line as an indicator of high power demand by other devices coupled to the power supply line.
13. The method of claim 10, wherein dynamically sensing properties of a power supply line comprises sensing voltage and/or current phase on the power supply line as an indicator of high power demand by other devices coupled to the power supply line.
- 20 14. The method of claim 10, wherein dynamically sensing properties of a power supply line comprises sensing properties of the supply power line while a connection of the supply power line to the electrical device is switched off.
15. The method of claim 10, wherein slowing or delaying device startup or activation in response to a sensed voltage drop on the power supply line comprises delaying device
25 startup or activation until the voltage on the power line recovers to a normal line voltage value.

16. The method of claim 10, wherein slowing or delaying device startup or activation in response to a sensed voltage drop on the power supply line comprises referring to a normal line voltage value.
17. The method of claim 16, wherein the normal line voltage value is an average power
5 supply line voltage value.
18. The method of claim 16, wherein the normal line voltage value is a power supply line voltage value immediately before switching on the electrical device.
19. An electrical system, comprising:
a plurality of electrical devices coupled to a power supply line;
10 wherein at least a first of the electrical devices has a signal-generating circuit that generates a signal indicative of power demand or use by the first device,
wherein at least a second of the electrical devices includes an activation or startup circuit directly responsive to the generated signal indicative of power demand or use by the first device, and
15 wherein the activation or startup circuit regulates or controls power use by the second device according to the signal indicative of power demand or use by the first device.
20. The electrical system of claim 19, wherein the signal-generating circuit emits a signal when the power demand or use by the first device exceeds a threshold value.
21. The electrical system of claim 19, wherein the signal-generating circuit emits a signal
20 when power demand or use by the first device falls below a threshold value.
22. The electrical system of claim 19, wherein the activation or startup circuit prevents or delays startup or activation or a high-power operation mode of the second device while the signal indicative of power demand or use by the first device is at or above a threshold value.

23. The electrical system of claim 19, wherein the activation or startup circuit allows startup or activation or a high-power operation mode of the second device only when the signal indicative of power demand by the first device is below a threshold value.
24. The electrical system of claim 19, wherein the activation or startup circuit turns off or
5 reduces power use by the second device while the signal indicative of power demand or use by the first device is at or above a threshold value.
25. The electrical system of claim 19, wherein the signal indicative of power demand or use by the first device is broadcast as an RF, ultrasonic or optical signal.
26. The electrical system of claim 19, wherein the signal indicative of power demand or
10 use by the first device is transmitted as an electrical signal modulating the power supply line.
27. The electrical system of claim 19, wherein the first device transmits the signal indicative of power demand or use by the first device according to a collision avoidance protocol.
- 15 28. The electrical system of claim 27, wherein the collision avoidance protocol includes transmission of the signal a random time interval after a determination that no other signal indicative of power demand or use by another of the electrical devices is present or detected propagating on the power supply line.
29. The electrical system of claim 27, wherein the collision avoidance protocol includes
20 transmission of the signal a device-specific time interval after a determination that no other signal indicative of power demand or use by another of the electrical devices is present or detected propagating on the power supply line.
30. The electrical system of claim 19, wherein one or more of the plurality of electrical
25 devices are arranged to turn-on only in assigned time windows relative to turn-on of an initial one of the plurality of electrical devices or relative to an event affecting power draw from the power supply line.

31. The electrical system of claim 19, wherein a multiplicity of electrical devices are arranged to turn-on in groups in a phased manner.
32. A method, comprising:
- 5 in an electrical system having a plurality of electrical devices coupled to a power supply line,
- generating a signal indicative of dynamic power demand or use by the first device,
- regulating or controlling power use by the second device according to the signal indicative of power demand or use by the first device.
33. The method of claim 32, wherein generating a signal indicative of dynamic power demand or use by the first device comprises generating a signal when the power demand or use by the first device exceeds a threshold value.
- 10
34. The method of claim 32, wherein generating a signal indicative of dynamic power demand or use by the first device comprises generating a signal when power demand or use by the first device falls below a threshold value.
35. The method of claim 32, wherein regulating or controlling power use by the second device comprises limiting power use by the second device while the signal indicative of power demand or use by the first device is at or above a threshold value.
- 15
36. The method of claim 32, wherein regulating or controlling power use by the second device comprises limiting allowing startup or activation or a high-power operation mode of the second device only when the signal indicative of power demand by the first device is below a threshold value.
- 20
37. The method of claim 32, wherein regulating or controlling power use by the second device comprises turning off or reducing power use by the second device while the signal indicative of power demand or use by the first device is at or above a threshold value.
- 25

38. The method of claim 32, wherein generating a signal indicative of dynamic power demand or use by the first device comprises broadcasting an RF, ultrasonic or optical signal.
39. The method of claim 32, wherein generating a signal indicative of dynamic power demand or use by the first device comprises transmitting an electrical signal modulating the power supply line.
40. The method of claim 32, wherein generating a signal indicative of dynamic power demand or use by the first device comprises transmitting the signal indicative of power demand or use by the first device according to a collision avoidance protocol.
41. The method of claim 40, wherein the collision avoidance protocol includes transmission of the signal a random time interval after a determination that no other signal indicative of power demand or use by another of the electrical devices is present or detected propagating on the power supply line.
42. The method of claim 40, wherein the collision avoidance protocol includes transmission of the signal a device-specific time interval after a determination that no other signal indicative of power demand or use by another of the electrical devices is present or detected propagating on the power supply line.
43. The method of claim 32, wherein one or more of the plurality of electrical devices are assigned to turn-on only in time windows relative to turn-on of an initial one of the plurality of electrical devices or relative to an event affecting power draw from the power supply line.
44. The method of claim 32, wherein a multiplicity of electrical devices are arranged to turn-on in groups in a phased manner.

FIG. 1

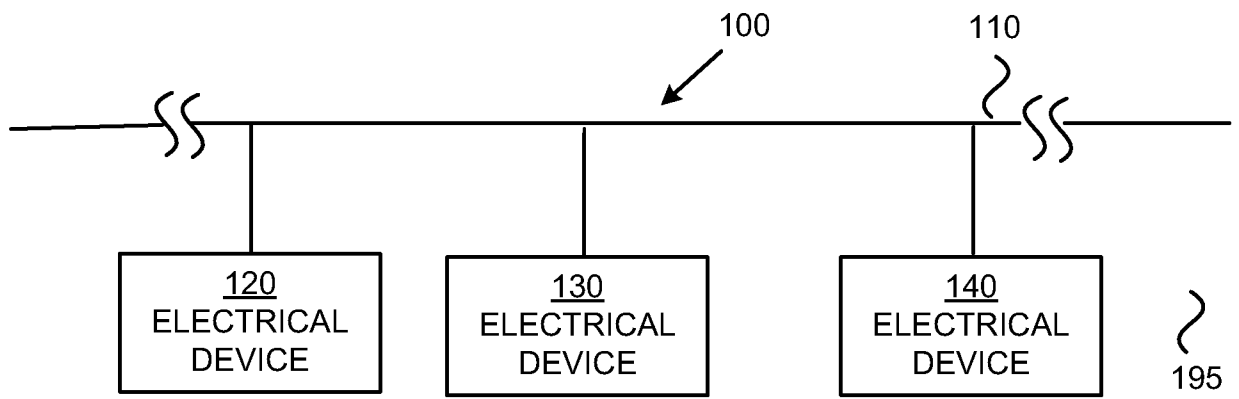

FIG. 2

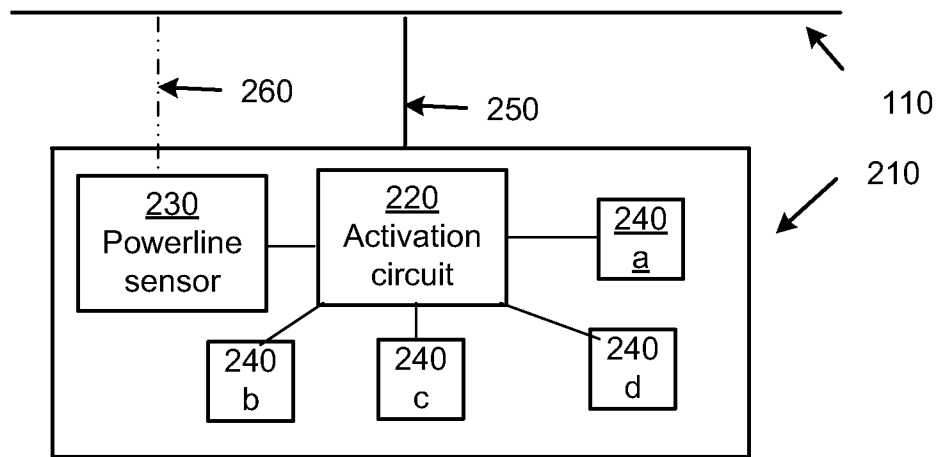

FIG. 3

300310

Dynamically sense properties of a power supply line for the device

320

In response to a sensed voltage drop on the power supply line at or about device startup or activation and/or about a peak power draw by the device from the power supply line,
slow or delay device startup or activation in response to a sensed voltage drop on the power supply line at or about device startup or activation and/or about a peak power draw by the device from the power supply line

FIG. 4

400

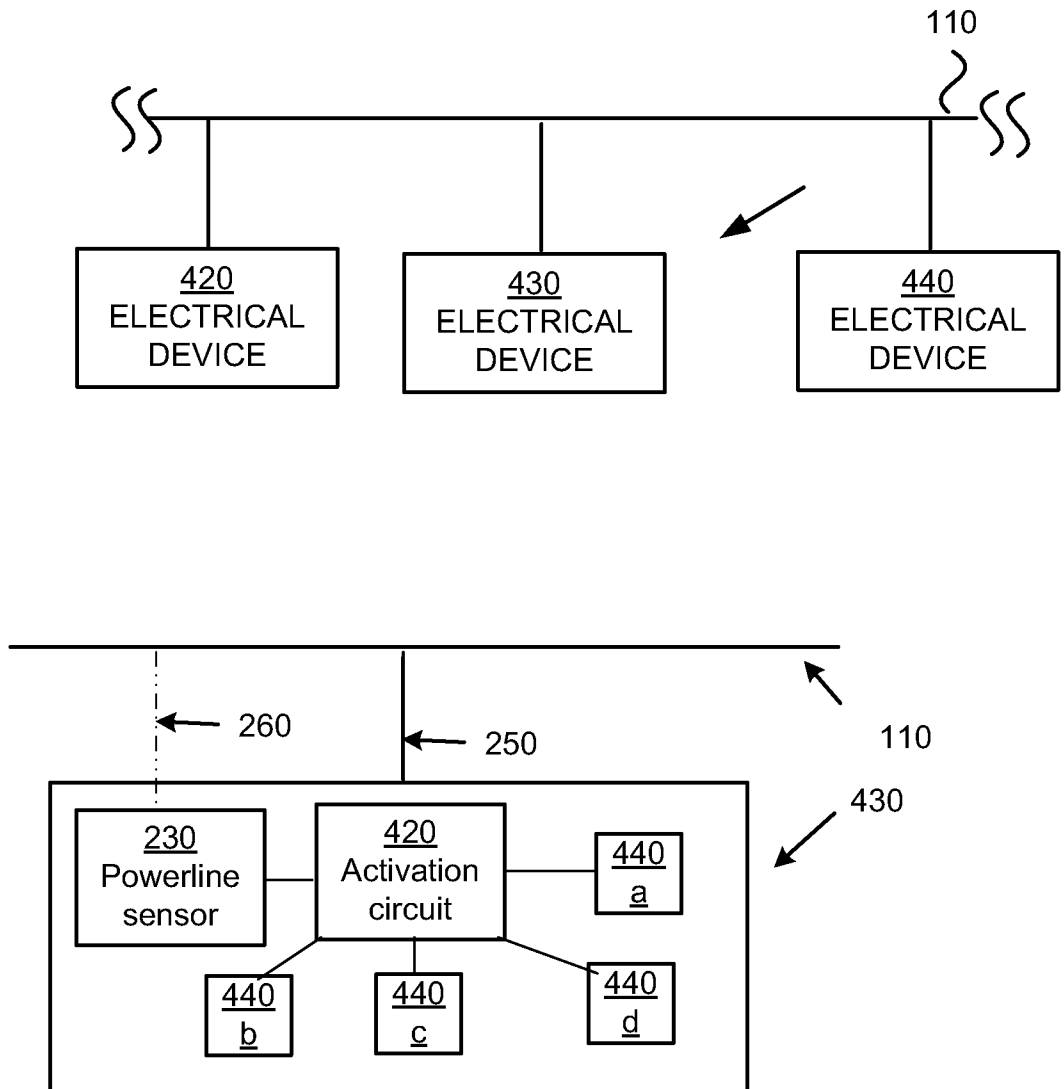

FIG. 5

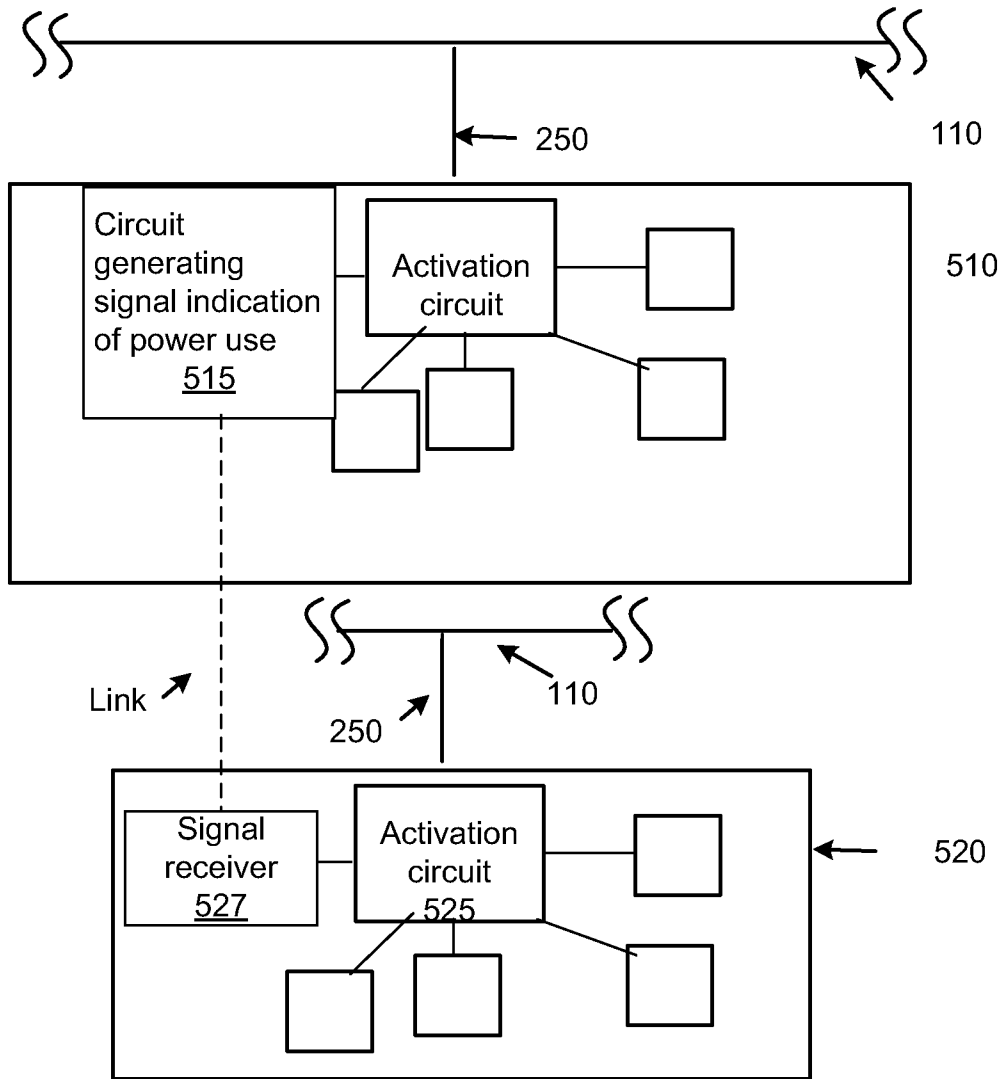

FIG. 6

600

610

In an electrical system having a plurality of electrical devices coupled to a power supply line, generate a signal indicative of dynamic power demand, draw or use by a first device

620

Regulate or control power use by a second device according to the signal indicative of power demand, draw or use by the first device

INTERNATIONAL SEARCH REPORT

International application No.

PCT/US2012/044951

A. CLASSIFICATION OF SUBJECT MATTER
 IPC(8) - H01H 47/00 (2012.01)
 USPC - 307/41
 According to International Patent Classification (IPC) or to both national classification and IPC

B. FIELDS SEARCHED
 Minimum documentation searched (classification system followed by classification symbols)
 IPC(8) - H01H 47/00, 47/02, 47/16 (2012.01)
 USPC - 307/41; 340/7.32, 669

Documentation searched other than minimum documentation to the extent that such documents are included in the fields searched

Electronic data base consulted during the international search (name of data base and, where practicable, search terms used)
 Micropatent.com; Orbit, Google Patent; Google Scholar

C. DOCUMENTS CONSIDERED TO BE RELEVANT

Category*	Citation of document, with indication, where appropriate, of the relevant passages	Relevant to claim No.
Y	US 6,741,442 B1 (MCNALLY et al) 25 May 2004 (25.05.2004) entire document	1-44
Y	US 7,894,219 B2 (ZONG et al) 22 February 2011 (22.02.2011) entire document	1-44
Y	US 2008/0077336 A1 (FERNANDES) 27 March 2008 (27.03.2008) entire document	2-4, 8, 9, 11-13, 17, 18, 25, 26, 38, 39
Y	US 5,818,821 A (SCHURIG) 06 October 1998 (06.10.1998) entire document	27-29, 40-42
Y	US 7,606,552 B2 (ORR et al) 20 October 2009 (20.10.2009) entire document	30, 43

Further documents are listed in the continuation of Box C.

* Special categories of cited documents:

"A" document defining the general state of the art which is not considered to be of particular relevance	"T" later document published after the international filing date or priority date and not in conflict with the application but cited to understand the principle or theory underlying the invention
"E" earlier application or patent but published on or after the international filing date	"X" document of particular relevance; the claimed invention cannot be considered novel or cannot be considered to involve an inventive step when the document is taken alone
"L" document which may throw doubts on priority claim(s) or which is cited to establish the publication date of another citation or other special reason (as specified)	"Y" document of particular relevance; the claimed invention cannot be considered to involve an inventive step when the document is combined with one or more other such documents, such combination being obvious to a person skilled in the art
"O" document referring to an oral disclosure, use, exhibition or other means	"&" document member of the same patent family
"P" document published prior to the international filing date but later than the priority date claimed	

Date of the actual completion of the international search 22 August 2012	Date of mailing of the international search report 13 SEP 2012
---	--

Name and mailing address of the ISA/US Mail Stop PCT, Attn: ISA/US, Commissioner for Patents P.O. Box 1450, Alexandria, Virginia 22313-1450 Facsimile No. 571-273-3201	Authorized officer: Blaine R. Copenheaver PCT Helpdesk: 571-272-4300 PCT OSP: 571-272-7774
---	---