

(19) World Intellectual Property Organization  
International Bureau



(43) International Publication Date  
10 October 2002 (10.10.2002)

PCT

(10) International Publication Number  
WO 02/080400 A2

- (51) International Patent Classification<sup>7</sup>: H04B 7/00
- (21) International Application Number: PCT/US02/09629
- (22) International Filing Date: 29 March 2002 (29.03.2002)
- (25) Filing Language: English
- (26) Publication Language: English
- (30) Priority Data: 09/823,011 30 March 2001 (30.03.2001) US
- (71) Applicant: QUALCOMM INCORPORATED [US/US]; 5775 Morhouse Drive, San Diego, CA 92121-1714 (US).
- (72) Inventors: CHEN, Tao; 5414 Harvest Run Drive, San Diego, CA 92130 (US). CHAPONNIERE, Etienne, F.; 870 Chalcedony Street, San Diego, CA 92109 (US).
- (74) Agents: WADSWORTH, Philip, R. et al.; Qualcomm Incorporated, 5775 Morehouse Drive, San Diego, CA 92121-1714 (US).
- (81) Designated States (*national*): AE, AG, AL, AM, AT, AU, AZ, BA, BB, BG, BR, BY, BZ, CA, CH, CN, CO, CR, CU, CZ, DE, DK, DM, DZ, EC, EE, ES, FI, GB, GD, GE, GH, GM, HR, HU, ID, IL, IN, IS, JP, KE, KG, KP, KR, KZ, LC, LK, LR, LS, LT, LU, LV, MA, MD, MG, MK, MN, MW, MX, MZ, NO, NZ, OM, PH, PL, PT, RO, RU, SD, SE, SG, SI, SK, SL, TJ, TM, TN, TR, TT, TZ, UA, UG, UZ, VN, YU, ZA, ZM, ZW.
- (84) Designated States (*regional*): ARIPO patent (GH, GM, KE, LS, MW, MZ, SD, SL, SZ, TZ, UG, ZM, ZW), Eurasian patent (AM, AZ, BY, KG, KZ, MD, RU, TJ, TM), European patent (AT, BE, CH, CY, DE, DK, ES, FI, FR, GB, GR, IE, IT, LU, MC, NL, PT, SE, TR), OAPI patent (BF, BJ, CF, CG, CI, CM, GA, GN, GQ, GW, ML, MR, NE, SN, TD, TG).

[Continued on next page]

(54) Title: METHOD AND APPARATUS FOR POWER CONTROL IN A COMMUNICATION SYSTEM

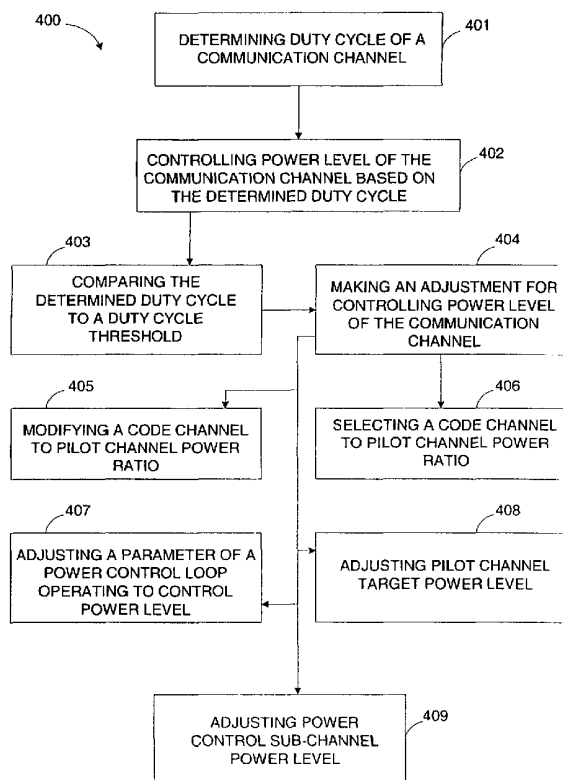

(57) Abstract: In a communication system (100), a method and apparatus provide for efficient power control between base station (101) and mobile stations (102-104). A controller is configured for determining duty cycle of a communication channel, and for controlling power level of the communication channel based on the determined duty cycle. The controller may compare the determined duty cycle against a duty cycle threshold. An adjustment for controlling power level may be based on the comparison.

WO 02/080400 A2



**Published:**

— without international search report and to be republished upon receipt of that report

*For two-letter codes and other abbreviations, refer to the "Guidance Notes on Codes and Abbreviations" appearing at the beginning of each regular issue of the PCT Gazette.*

## Method and Apparatus for Power Control in a Communication System

### Background

#### Field

[0001] The present invention relates generally to the field of communications, and more specifically, to communications in the code division multiple access communication system.

#### Background

[0002] Code division multiple access (CDMA) communication systems have been in commercial operations for a number of years. In CDMA communication systems, a number of users in the same geographical area may choose to operate on a common carrier frequency. The signal from each user is encoded according to a unique assigned code. A receiver decodes each signal according to the assigned code. A receiver may receive signals from different users with common carrier frequency. While a signal for one user is being decoded, the signals transmitted from all other users may be treated as interference. Excessive transmission level may cause interference on other signals. In a CDMA system, the power level of signals transmitted by different users of the system is controlled to control the interference level. Moreover, for effective utilization of the channel resources in the CDMA communication system, the power level of each transmitted signal is controlled. The power level of each signal is controlled at the transmitter to maintain an adequate quality of reception at a receiving end. Other reasons,

such as conserving battery power, for controlling power level of signals in a CDMA system are well known by one of ordinary skill in the relevant art.

[0003] To this end as well as others, there is a need for an effective signal power control in a CDMA communication system.

### SUMMARY

[0004] In a communication system, a method and apparatus provide for efficient power control between a base station and mobile stations. A controller is configured for determining duty cycle of a communication channel, and for controlling power level of the communication channel based on the determined duty cycle. The controller may compare the determined duty cycle against a duty cycle threshold. An adjustment for controlling power level may be based on the comparison.

### BRIEF DESCRIPTION OF THE DRAWINGS

[0005] The features, objects, and advantages of the present invention will become more apparent from the detailed description set forth below when taken in conjunction with the drawings in which like reference characters identify correspondingly throughout and wherein:

[0006] FIG. 1 illustrates a communication system capable of operating in accordance with various embodiments of the invention;

[0007] FIG. 2 illustrates a communication system receiver, for operation in a mobile station and a base station, capable of operating in accordance with various embodiments of the invention;

[0008] FIG. 3 illustrates a flow chart for controlling power level of a communication channel between a mobile station and a base station, capable of having adjusted operating parameters in accordance with various embodiments of the invention; and

[0009] FIG. 4 illustrates a flow chart used for controlling power level of a communication channel between a base station and a mobile station in accordance with various embodiments of the invention.

#### Detailed Description of the Preferred Embodiment(s)

[00010] A system for wireless communications in accordance with the code division multiple access (CDMA) technique has been disclosed and described in various standards published by the Telecommunication Industry Association (TIA). Such standards include the TIA/EIA-95 standard, TIA/EIA-IS-2000 standard, IMT-2000 standard, and WCDMA standard, all incorporated by reference herein. A copy of the standards may be obtained by accessing the world wide web at the address: <http://www.cdg.org>, or by writing to TIA, Standards and Technology Department, 2500 Wilson Boulevard, Arlington, VA 22201, United States of America. The "3<sup>rd</sup> Generation Partnership Project" (3GPP) is embodied in a set of documents include Document No. 3G TS 25.211, 3G TS 25.212, 3G TS 25.213, and 3G TS 25.214, and known as the WCDMA standard; the "TIA/EIA/IS-95 Remote Station-Base Station Compatibility Standard for Dual-Mode Wideband Spread Spectrum Cellular System" is known as the IS-95 standard; the "TR-45.5 Physical Layer Standard for cdma2000 Spread Spectrum Systems" is known

as the CDMA-2000 standard; each incorporated by reference herein. The specification generally identified as WCDMA specification, incorporated by reference herein, may be obtained by contacting 3GPP Support Office, 650 Route des Lucioles-Sophia Antipolis, Valbonne-France.

[00011] Generally stated, a novel and improved method and an accompanying apparatus provide for efficient control of signal power level in a CDMA communication system. One or more exemplary embodiments described herein are set forth in the context of a digital wireless data communication system. While use within this context is advantageous, different embodiments of the invention may be incorporated in different environments or configurations. In general, the various systems described herein may be formed using software-controlled processors, integrated circuits, or discrete logic. The data, instructions, commands, information, signals, symbols, and chips that may be referenced throughout the application are advantageously represented by voltages, currents, electromagnetic waves, magnetic fields or particles, optical fields or particles, or a combination thereof. In addition, the blocks shown in each block diagram may represent hardware or method steps. The exemplary embodiment described herein is set forth in the context of a digital communication system. While use within this context is advantageous, different embodiments of the invention may be incorporated in different environments or configurations. In general, the various systems described herein may be formed using software-controlled processors, integrated circuits, or discrete logic. The data, instructions, commands, information, signals, symbols, and chips that may be referenced throughout the application may be represented by voltages, currents, electromagnetic

waves, magnetic fields or particles, optical fields or particles, or a combination thereof. In addition, the blocks shown in each block diagram may represent hardware or method steps.

[00012] FIG. 1 illustrates a general block diagram of a communication system 100 capable of operating in accordance with any of the code division multiple access (CDMA) communication system standards. Generally, communication system 100 includes a base station (BS) 101 that provides communication links between a number of mobile stations, such as mobile stations 102-104, and between the mobile stations 102-104 and a wireline network 105. BS 101 may include a number of components, such as a mobile station controller, a base station controller, and a radio frequency transceiver. For simplicity, such components are not shown. BS 101 may also be in communication with other base stations (not shown.) BS 101 communicates with each mobile station 102-104 via a forward link. The forward link may be maintained by a forward link signal transmitted from BS 101. The forward link signals targeted for several mobile stations 102-104 may be summed to form a forward link signal 106. Each of the mobile stations 102-104 receiving forward link signal 106 decodes the forward link signal 106 to extract the information that is targeted for its user. At the receiving end, the receiver may treat as interference the portion of the received forward link signal 106 targeted for others.

[00013] Mobile stations 102-104 communicate with BS 101 via a corresponding reverse link. Each reverse link is maintained by a reverse link signal, such as reverse link signals 107-109 for respectively mobile stations 102-104. BS 101 may also transmit a predefined series of data bits on a pilot channel via the forward link to all mobile stations to assist each mobile station in decoding the

forward link signal 106. Each of the mobile stations 102-104 may transmit a pilot channel to BS 101. The pilot channel transmitted from a mobile station may be used for decoding the information carried by the reverse link signal transmitted from the same mobile station. The use and operation of a pilot channel are well known. A transmitter and a receiver for communicating via the forward and reverse links are included in each mobile stations 102-104, and BS 101.

[00014] FIG. 2 illustrates a block diagram of a receiver 200 used for processing CDMA signals. Receiver 200 demodulates the received signal to extract the information carried by the received signal. Receive (Rx) samples are stored in RAM 204. Receive samples are generated by a radio frequency/intermediate frequency (RF/IF) system 290 and an antenna system 292. Antenna system 292 receives an RF signal, and passes the RF signal to RF/IF system 290. RF/IF system 290 may be any conventional RF/IF receiver. The received RF signals are filtered, down-converted, and digitized to form RX samples at baseband frequencies. The samples are supplied to a demultiplexer (demux) 202. The output of demux 202 is supplied to a searcher unit 206, and finger elements 208. A control system unit 210 is coupled thereto. A combiner 212 couples a decoder 214 to finger elements 208. Control unit 210 may be a microprocessor controlled by software, and may be located on the same integrated circuit or on a separate integrated circuit.

[00015] During operation, receive samples are supplied to demux 202. Demux 202 supplies the samples to searcher unit 206, and finger elements 208. Control unit 210 configures finger elements 208 to perform demodulation of



the received signal at different time offsets based on search results from searcher unit 206. The results of the demodulation are combined and passed to decoder 214. Decoder 214 decodes the data, and outputs the decoded data.

[00016] In general for searching, searcher 206 may use non-coherent demodulation of a pilot channel to test timing hypotheses and phase offsets corresponding to various transmitting sources and multi-paths. The demodulation performed by finger elements 208 may be performed via coherent demodulation of other channels such as control and traffic channels. The information extracted by searcher 206 by demodulating a pilot channel may be used in finger elements 208 for demodulation of other channels. The searcher 206 and finger elements 208 may provide both pilot channel searching, and demodulation of control and traffic channels. The demodulation and searching can be performed at various time offsets. The results of the demodulation may be combined in combiner 212 before decoding the data transmitted on each channel. Despreading of the channels is performed by multiplying the received samples with the complex conjugate of the PN sequence and assigned Walsh function at a single timing hypothesis, and digitally filtering the resulting samples, often with an integrate and dump accumulator circuit (not shown). Such a technique is commonly known in the art. Receiver 200 may be used in BS 101 and mobile stations 102-104 for decoding the information on respectively reverse and forward links signals. BS 101 may employ several of receiver 200 to decode the information transmitted from several mobile stations at the same time.

[00017] Receiver 200 may also perform interference cancellation through a correlation process. The received samples, after being read from RAM 204, are passed through a correlation process for each received signal. The correlation process may collectively be described as the operations of searcher 206, finger element 208, and combiner 212. Since the received samples contain samples from the signals transmitted from more than one transmitting source, the correlation process may be repeated for each received signal. The correlation process for each received signal may be unique because each signal may require a different correlation parameters as of those found in operations of searcher 206, finger element 208, and combiner 212. Each signal may include a traffic channel and a pilot channel. The PN sequence assigned to the traffic channel and pilot channel carried by each signal may be different. The correlation process may include channel estimation, which includes estimating the channel fading characteristics based on the result of correlating with the pilot channel. The channel estimation information is used for correlating with the traffic channel. Each traffic channel is then decoded.

[00018] The result from each correlation process may pass through a decoding process in decoder 214. If the transmitted channel is encoded via a convolutional encoding process, decoding step 214 is performed according to the utilized convolutional code. If the transmitted channel is encoded via a turbo encoding process, decoding step 214 is performed according to the utilized turbo code.

[00019] Each signal may be decoded to provide enough information about whether a pass indicator is produced for each cyclic redundancy check (CRC)

associated with each transmitted frame of data. Operation and use of CRC in a communication system are well known. If the CRC is passed, the decoded result of the channel associated with the passed CRC may be passed on for further receiving operation.

[00020] The signals received by BS 101 may be input to receiver 200. Antenna system 292 and RF/IF system 290 receive the signals from the mobile stations to produce the samples of the received signals. The received samples may be stored in RAM 204. Receiver 200 may incorporate a number of searchers 206, a number of finger elements 208, a number of combiners 212, and a number of decoders 214 for simultaneously performing the correlation process and the decoding process for all the signals received from different mobile stations. However, only one antenna system 292 and RF/IF system 290 may be necessary.

[00021] Each time a correlation process is started, searcher 206 and finger element 208 may start anew for determining non-coherent demodulation of a pilot channel to test timing hypotheses and phase offsets. Searcher 206, or finger element 208, or searcher 206 and finger element 208 in combination, may determine the signal to interference ratio (S/I) for each received signal. The ratio  $E_b/I$  may be synonymous with the ratio S/I. The ratio  $E_b/I$  is a measure of signal energy over interference per unit of a data symbol or data bit. Therefore, S/I and  $E_b/I$  may be interchangeable in some respects. The interference (I) may typically be defined as the power spectral density of interference and the thermal noise.

[00022] To control interference, the system controls the signal level transmitted from each transmitting source, or the data rate of the communication link, or

both. Generally, each MS determines the needed reverse link power level to support both the traffic channel and the pilot channel. Various power control schemes for controlling power levels of signals transmitted from an MS in a communication system are known. One or more examples are described in the Mobile Station-Base Station Compatibility Standard for Wideband Spread Spectrum Cellular Systems, otherwise known as TIA/EIA-95 and TIA/EIA-2000 standards, incorporated by reference herein. The output power level of each MS is controlled by two independent control loops, open loop and closed loop. The open loop power control is based on the need of each MS to maintain an adequate communication link with the BS. Therefore, the MS closer to the BS needs less power than the MS further away. A strong receive signal at the MS indicates less propagation loss between the MS and the BS, and, thus, requires a weaker reverse link transmit power level. In the open loop power control, the MS sets the transmit power level of the reverse link based on independent measurements of S/I of at least one received channel, such as pilot, paging, sync, and traffic channels. The MS may make the independent measurement prior to power level setting on the reverse link.

[00023] FIG. 3 illustrates a flow diagram 300 of an exemplary closed loop power control method. Operation of closed loop power control method 300 begins once an MS in communication system 100 seizes a forward link traffic channel. After the initial access attempt by the MS, the MS sets an initial reverse channel power level. The initial power level setting on the reverse link is then adjusted during the communication link via the closed loop power level control 300. The closed loop power control 300 operates with a faster response time than the open loop control. The closed loop power control 300

provides correction to the open loop power control. The closed loop power control 300 operates in conjunction with the open loop control during a traffic channel communication link to provide the reverse link power control with a large dynamic range.

[00024] To control the power level of the reverse link signal of a mobile station via the closed loop 300, BS 101 at step 301 measures the signal to interference ratio (S/I) of the reverse link signal transmitted from the mobile station. The measured S/I is compared with a set point S/I at step 302. The measured S/I may be in the form of  $E_b/I$  which is a ratio of bit energy over interference, and consequently, the set point may be in the same form. The set point is selected for the mobile station. The set point may be initially based on open loop power setting by the mobile station.

[00025] If the measured S/I is higher than the set point, at step 303, BS 101 orders the mobile station to power down the power level of its reverse link signal by an amount, for example 1 dB. When the measured S/I is higher than the set point, it indicates that the mobile station is transmitting on the reverse link at a signal power level higher than is needed to maintain an adequate reverse link communication. As a result, the mobile station is ordered to lower the signal power level of its reverse link to reduce the overall system interference. If the measured S/I is lower than the set point, at step 304, BS 101 orders the mobile station to power up the power level of its reverse link signal by an amount, for example 1 dB. When the measured S/I is lower than the set point, it indicates that the mobile station is transmitting on the reverse link at a signal power level lower than is needed to maintain an adequate reverse link communication. As a result of increasing the power

level, the mobile station may be able to overcome the interference level and may provide an adequate reverse link communication.

[00026] The operations performed at steps 302-304 may be referred to as the inner loop power control. The inner-loop power control keeps the reverse link (S/I) at the BS 101 as close as possible to its target threshold as provided by the set point. The target S/I is based on the set point selected for the mobile station. The power up or power down may be performed several times during a time frame. One time frame may be divided into 16 power control groups. Each power control group consists of several data symbols. The power up or power down command may be transmitted 16 times per frame. If one frame of data has not been received at step 305, the power control loop 300 continues to measure S/I of the reverse link signal during the next power control group at step 301. The process is repeated at steps 302-304 until at least one frame of data is received from the mobile station.

[00027] A single set point or target may not be satisfactory for all conditions. Therefore, the set point used at step 302 may also change depending on a desired reverse link frame error rate. If one frame of data has been received at step 305, a new S/I set point may be calculated at step 306. The new set point becomes the new S/I target for the mobile station. The new set point may be based on a number of factors including the frame error rate. For example, if the frame error rate is above a predetermined level, indicating unacceptable frame error rate, the set point may be raised to a higher level. By raising the set point to a higher level, the mobile station consequently increases its reverse link transmit power level via the comparison at step 302 and power up command at step 304. If the frame error rate is below a

predetermined level indicating above an acceptable frame error rate, the set point may be lowered to a lower level. By lowering the set point to a lower level, the mobile station consequently decreases the reverse link transmit power level via the comparison at step 302 and power down command at step 303. The operations performed at steps 305-306, looping back from step 306 to step 302 to indicate a new set point, and looping back to step 301 for measuring the S/I of the new frames, may be viewed as the outer loop operation. The outer-loop power control may command once every frame, and the closed loop power control may command once every power control group. One frame and one power control group may be, respectively, 20 and 1.25 mSec long.

[00028] The system may also employ a forward link power control scheme to reduce interference. The MS communicates to the BS periodically about the voice and data quality. The frame error rate and quality measurements are reported to the BS via a power measurement report message. The message contains the number of frames received in error on the forward link during an interval. The power level of the forward link signal is adjusted based on the number of frame errors. Since such a quality measurement feedback is based on the frame error rate, such a mode of the forward link power control is much slower than reverse link power control. For fast response, a reverse link erasure bit may be used to inform the BS whether the previous frame was received with or without error. The channel power gain may be continuously adjusted while monitoring the message or the erasure bit as a way of controlling forward link power level.

[00029] For communication of data, the forward link may be transmitted to the MS at a fixed power level while adjusting the effective forward link data rate targeted for the MS. The data rate adjustment on the forward link when viewed for the overall system is a form of interference control. Note that the forward link power control is generally for controlling interference in a coverage area, and/or for sharing a limited communication resources. When the feedback quality measurement is indicating poor reception, the data rate may be lowered while keeping the power level constant to overcome the effect of the interference. The data rate may also be lowered to allow other mobile stations to receive forward link communication at a higher data rate.

[00030] According to at least one of the CDMA Spread Spectrum System standards, incorporated by reference herein, in addition to the open loop and closed loop power control schemes, the MS adjusts the output power level by attributes of a code channel as specified by the standard. In CDMA-2000, the MS sets the output power of the enhanced access channel header, the enhanced access channel data, and the reverse common control channel data relative to the output power level of the reverse pilot channel. The output power level of the reverse pilot channel is set by the open and closed loop power controls. The MS maintains a power level ratio between the code channel power level and the reverse pilot channel power level. The ratio may be defined by the data rate used in the code channel. Generally, a table provides the values for the ratio at different data rates. The ratio generally increases for higher data rates. A ratio equal to one or less than one may also be possible. At a ratio equal to one, the power level of the pilot channel as set by the power control loop 300 is equal to the power level of the code



channel. During transmission of data on a traffic channel, the data rate and the traffic channel power level may be adjusted. The power level may be selected based on a relative power of the reverse link pilot. Once an allowable data rate is selected, a corresponding channel gain with respect to the reverse link pilot power level is used to set the traffic channel power level.

[00031] In data mode, a BS may be providing communication links to a large number of MSs at different data rates. For example, one MS in a forward link connected state may be receiving data at a low data rate, and another MS receiving at a high data rate. On the reverse link, the BS may be receiving a number of reverse link signals from different MSs. An MS based on an independent measurement may decide and request a desired data rate from the BS. The desired forward link data rate may be communicated to the BS via a data rate control (DRC) channel. The data rate may also be selected by the base station based on certain metrics. The metrics may include the transmit power level of the power control sub-channel and/or power level of one or more forward traffic channels. The BS attempts to provide a forward link data transfer at the requested data rate.

[00032] On the reverse link, the MS may autonomously select a reverse link data rate from a number of possible reverse link data rates. The selected data rate may be communicated to the BS via a reverse rate indicator channel. The MS may request a desired data rate or request a non-specified data rate. The BS in response may determine a data rate that the MS may use. The BS communicates to the MS at the determined data rate. The determined data rate may be used for a limited duration. The duration may be determined by the BS. Each MS may also be limited to a predetermined

grade of service. A grade of service may limit the maximum available data rate on the forward and/or reverse links. Moreover, the communication of data may not be continuous in a way that, perhaps, voice data is communicated. A receiver may be receiving packets of data at different intervals. The interval for different receiver may be different. For example, a receiver may be receiving data sporadically while another receiver may be receiving data packets within short time intervals.

[00033] Communication of data at high data rates takes a greater transmit/receive signal power level than at low data rates. The forward and reverse links may have similar data rate activities in the case of voice communications. The forward and reverse links data rates may be limited to low data rates since the voice information frequency spectrum is limited. Possible voice data rates are commonly known and described in a code division multiple access (CDMA) communication system standard such as IS-95 and IS-2000, incorporated by reference herein. For data communications, however, the forward and reverse links may not have similar data rates. For example, an MS may be retrieving a large data file from a database. In such a case, the communication on the forward link is predominantly occupied for transmission of data packets. The data rate on the forward link may reach 2.5 Mbps in a data mode. The data rate on the forward link may be based on a data rate request made by the MS. On the reverse link, the data rate may be lower, and may range from 4.8 to 153.6 Kbps.

[00034] Generally, in communication system 100, in accordance with various embodiments, duty cycle of a communication channel is determined, and power level of the communication channel is controlled based on the

determined duty cycle. Each transmission of the communication channel may be in a time frame, For example, each time frame may be for duration of 20 mSec. The data rate of each time frame may range from 1250 to 14400 bits per seconds. As such, the number of bits in each frame may be different depending on the data rate. The channel may be used for communication of user and signaling information during a call between the user and a destination. The user may be using a mobile station, such as mobile stations, 102-104 for the call. Any of the mobile stations 102-104 may be a cellular phone. The destination may be base station 101.

[00035] In accordance with an embodiment, the communication channel may a dedicated control channel (DCCH). A DCCH channel may be used for communication of user and signaling information for maintaining a traffic data call between a user and a destination, such as, respectively, mobile stations 102-104 and base station 101. The number of DCCH frames transmitted over a period of time may be different depending on the usage. As such, the time between transmission of DCCH time frames during the traffic data call may be different. For example, even though traffic data may be communicated, a transmission of a frame of the communication channel, such as DCCH, may not necessarily take place. In another situation, several time frames of the communication channel, such as DCCH, may be transmitted in a short period of time. Therefore, the duty cycle of the transmission of the frames of the communication channel, such as DCCH, may be different at different times. To effectively control transmission power level of the communication, in accordance with various embodiments, the power level of the communication

channel, such as DCCH, is based on the duty cycle of the frame transmission of the communication channel.

[00036] In accordance with various embodiments, the determined duty cycle may be compared against a duty cycle threshold. The duty cycle threshold may be predetermined. The duty cycle may be determined by a control system in communication system 100. The duty cycle may be based on a communication history of received or transmitted frames. One such a control system may reside in mobile stations 102-104, such as control system unit 210, or in base station 101. In case when a controller in base station 101 determines the duty cycle, the determined duty cycle may be communicated to the mobile station 102-104 in communication with base station 101. The control system may perform a process for comparing the determined duty cycle to a duty cycle threshold. The duty cycle threshold may be adjusted from time to time.

[00037] Depending on the difference between the determined duty cycle and the duty cycle threshold, an adjustment may be made for controlling power level of the communication channel. Such an adjustment may be made in different ways to effect the power level of the communication channel. For example, when the duty cycle reaches a level close to a continuous transmission, the adjustment may be minimal, or no adjustment at all. When the duty cycle is low, the channel condition may change drastically between the transmissions. In case of low duty cycle, the adjustment may be more than minimal.

[00038] In accordance with an embodiment, the adjustment for controlling power level of the DCCH may be in a form of modifying a code channel to

pilot channel power ratio associated with a traffic channel between the user and the destination. The user may be a mobile station 102-104, and the destination may be base station 101. The modified code channel to pilot channel power ratio may be used to control power level of the DCCH. Such a modification may be in a form of providing a correction factor. The correction factor may be applied to the code channel to pilot channel power ratio to arrive at the modified ratio. In another example, a table with predetermined entries may be used for selecting the modified ratio. The entries in the table may be derived from the ratios used for the traffic channel. The entries may also, or alternatively, depend on factors such as the speed of the channel fading, the number of multi-paths at the receiver, and transmit and receive signal and antenna diversity.

[00039] The difference between the traffic channel power ratio and the modified ratio for the DCCH channel may depend on the difference between the determined duty cycle and the duty cycle threshold. For example, when the duty cycle is high, the difference between the determined duty cycle and the threshold may be minimal. In case of high duty cycle, the difference between the traffic channel power ratio and the modified power ratio used for the DCCH may be minimal. In case of low duty cycle, the difference between the determined duty cycle and the duty cycle threshold may be high. In case of low duty cycle, the channel characteristic may have changed drastically between the transmissions. In case of low duty cycle, the difference between the traffic channel power ratio and the modified power ratio used for DCCH may be more than minimal. Depending on the determined duty cycle, a code channel to pilot channel power ratio may be selected and used for controlling

the DCCH power level. In case the ratio for controlling the power level of the DCCH is determined by base station 101, the selected or modified ratio may be communicated to the mobile station 102-104 in communication with base station 101.

[00040] In accordance with various embodiments, the communication channel may be between mobile station 102-104 and base station 101. Normally, for controlling signal power level between the mobile stations 102-104 and base station 101, each mobile station 102-104 may have a power control loop in base station 101. Each power control loop, such as power control loop 300, is operating to control the signal power level between a mobile station 102-104 and base station 101. A power control loop may include one or more parameters for its operation. For example, power control loop 300 includes S/I set point. The set point parameter is calculated at step 306. To calculate the set point, the frame error rate is compared to a threshold. The frame error rate threshold is another parameter used in operation of power control loop 300. The set point parameter is used at step 302 to decide whether to step up or down the power level of the signal transmitted from the mobile station 102-104. In accordance with various embodiments, the set point parameter may be adjusted, based on the duty cycle, at the power control outer loop at base station 101. In alternative or in combination, the frame error rate threshold may be adjusted, based on the duty cycle, to effect an increase or decrease in transmit power level of signals from the mobile station 102-104.

[00041] In accordance with various embodiments, the code channel to pilot channel power ratio may be indirectly adjusted by adjusting a target power level of the pilot channel for controlling power level of the communication

channel. The adjustment may be based on the duty cycle. By keeping the power ratio the same and adjusting the pilot channel target power level, the amount of power allocated to the communication channel may be controlled. Such a control is based on the determined duty cycle. When the communication channel is between a mobile station 102-104 and a base station 101, the adjusted target power level of the pilot channel may be communicated to the mobile station in communication with base station 101. The communication channel, in this case, and the pilot channel originate from the mobile station.

[00042] In accordance with various embodiments, controlling the power level of the communication channel based on the determined duty cycle may be by adjusting a power level of a power control sub-channel. A power control sub-channel may be used by base station 101 for controlling reverse link channels. In this case, the power control sub-channel originates from the base station 101. Base station 101 transmits power control sub-channel at a power level with respect to the forward link traffic channel. The power level may be adjustable and fixed in relative to the forward link traffic channel. The mobile stations 102-104 measure the difference between the power levels of the power control sub-channel and the forward link traffic channel. The mobile stations 102-104 use the measured difference in calculation of determining a frame error rate set point. The frame error rate set point is communicated to the base station 101. Base station 101 takes into effect the received frame error rate set point in the power control loop 300 for adjusting the power level of the communication channel.

[00043] Referring to FIG. 4, a flow chart 400 for controlling power level of a communication channel is shown in accordance with various embodiments. At step 401, the duty cycle of the communication channel, such as DCCH, is determined. At step 402, a controller in base station 101, or controller 210 in mobile stations 102-104 may decide whether to control power level of the communication channel based on the determined duty cycle. At step 403, the determined duty cycle is compared to a duty cycle threshold. Based on the comparison which determines the difference between the threshold and the determined duty cycle, an adjustment may be made for controlling power level of the communication channel. The adjustment may be made by several ways. At step 405, modifying a code channel to pilot channel power ratio may be incorporated for making the adjustment for controlling the power level of the communication channel at step 404. At step 406, a code channel to pilot channel ratio may be selected, for example from a table, to control the power level. At step 407, a parameter associated with a power control loop, such as power control loop 300, may be adjusted to control the power level. At step 408, the target level for the pilot channel may be changed to effect the power level of the communication channel. At step 409, the power level of the power control sub-channel may be adjusted to control the power level of the communication channel. The adjustments shown in flow chart 400 may be made in any combinations or individually.

[00044] Those of skill in the art would further appreciate that the various illustrative logical blocks, modules, circuits, and algorithm steps described in connection with the embodiments disclosed herein may be implemented as electronic hardware, computer software, or combinations of both. To clearly



illustrate this interchangeability of hardware and software, various illustrative components, blocks, modules, circuits, and steps have been described above generally in terms of their functionality. Whether such functionality is implemented as hardware or software depends upon the particular application and design constraints imposed on the overall system. Skilled artisans may implement the described functionality in varying ways for each particular application, but such implementation decisions should not be interpreted as causing a departure from the scope of the present invention.

[00045] The various illustrative logical blocks, modules, and circuits described in connection with the embodiments disclosed herein may be implemented or performed with a general purpose processor, a digital signal processor (DSP), an application specific integrated circuit (ASIC), a field programmable gate array (FPGA) or other programmable logic device, discrete gate or transistor logic, discrete hardware components, or any combination thereof designed to perform the functions described herein. A general purpose processor may be a microprocessor, but in the alternative, the processor may be any conventional processor, controller, microcontroller, or state machine. A processor may also be implemented as a combination of computing devices, e.g., a combination of a DSP and a microprocessor, a plurality of microprocessors, one or more microprocessors in conjunction with a DSP core, or any other such configuration.

[00046] The steps of a method or algorithm described in connection with the embodiments disclosed herein may be embodied directly in hardware, in a software module executed by a processor, or in a combination. A software module may reside in RAM memory, flash memory, ROM memory, EPROM

memory, EEPROM memory, registers, hard disk, a removable disk, a CD-ROM, or any other form of storage medium known in the art. An exemplary storage medium is coupled to the processor such that the processor can read information from, and write information to, the storage medium. In the alternative, the storage medium may be integral to the processor. The processor and the storage medium may reside in an ASIC. The ASIC may reside in a user terminal. In the alternative, the processor and the storage medium may reside as discrete components in a user terminal.

[00047] The previous description of the preferred embodiments is provided to enable any person skilled in the art to make or use the present invention. The various modifications to these embodiments will be readily apparent to those skilled in the art, and the generic principles defined herein may be applied to other embodiments without the use of the inventive faculty. Thus, the present invention is not intended to be limited to the embodiments shown herein but is to be accorded the widest scope consistent with the principles and novel features disclosed herein.

What is claimed is:

## Claims

1. In a communication system, a method comprising:  
2 determining duty cycle of a communication channel;  
controlling power level of said communication channel based on said  
4 determined duty cycle.

2. The method as recited in claim 1 further comprising:  
2 comparing said determined duty cycle against a duty cycle threshold;  
wherein an adjustment for controlling power level via said controlling is based  
4 on said comparing.

3. The method as recited in claim 1 further comprising:  
2 informing a mobile station of said determined duty cycle.

4. The method as recited in claim 1, wherein said controlling comprises  
2 of selecting a code channel to pilot channel power ratio for controlling power  
level of said communication channel.

5. The method as recited in claim 4 further comprising:  
2 informing a mobile station of said selected code channel to pilot  
channel power ratio.

6. The method as recited in claim 1 wherein said communication  
2 channel is between a mobile station and a base station, wherein said  
controlling comprises:

4 adjusting a parameter of a power control outer loop at said base  
station, wherein said power control outer loop is operating to control power  
6 level of a signal transmitted from said mobile station.

7. The method as recited in claim 1 wherein said communication  
2 channel is between a mobile station and a base station, wherein said  
controlling comprises:

4 adjusting a frame error rate set point, at said mobile station, of a power  
control outer loop, wherein said power control outer loop is operating to  
6 control power level of a signal transmitted from said mobile station.

8. The method as recited in claim 1 wherein said communication  
2 channel is a dedicated control channel.

9. The method as recited in claim 8, wherein said controlling comprises  
2 of modifying a code channel to pilot channel power ratio associated with a  
traffic channel.

10. The method as recited in claim 9 further comprising:  
2 using said modified code channel to pilot channel power ratio to control  
power level of said dedicated control channel.

11. The method as recited in claim 1 wherein said controlling  
2 comprises of adjusting a target power level of a pilot channel for controlling  
power level of said communication channel.

12. The method as recited in claim 11 wherein said communication  
2 channel is between a mobile station and a base station, further comprising:  
communicating said adjusted target power level of said pilot channel to  
4 said mobile station.

13. The method as recited in claim 11 wherein said communication  
2 channel is between a mobile station and a base station, wherein said pilot  
channel originates from said mobile station.

14. The method as recited in claim 1 wherein said controlling  
2 comprises of adjusting a power level of a power control sub-channel.

15. The method as recited in claim 14 wherein said communication  
2 channel is between a mobile station and a base station, wherein said power  
control sub-channel originates from said base station.

16. In a communication system, an apparatus comprising:  
2 a controller configured for determining duty cycle of a communication  
channel;  
4 wherein said controller further configured for controlling power level of  
said communication channel based on said determined duty cycle.

17. The apparatus as recited in claim 1, wherein said controller is  
2 configured for comparing said determined duty cycle against a duty cycle

threshold, and wherein an adjustment for controlling power level via said  
4 controlling is based on said comparing.

18. The apparatus as recited in claim 16 further comprising:  
2 a transmitter configured for informing a mobile station, via a receiver in  
said mobile station, of said determined duty cycle.

19. The apparatus as recited in claim 16, wherein said controller is  
2 configured for performing said controlling by selecting a code channel to pilot  
channel power ratio for controlling power level of said communication  
4 channel.

20. The apparatus as recited in claim 19 wherein said transmitter is  
2 configured for informing a mobile station of said selected code channel to pilot  
channel power ratio.

21. The apparatus as recited in claim 16 wherein said communication  
2 channel is between a mobile station and a base station, wherein said  
controller is configured for said controlling by adjusting a parameter of a  
4 power control outer loop at said base station, wherein said power control  
outer loop is operating to control power level of a signal transmitted from said  
6 mobile station.

22. The apparatus as recited in claim 16 wherein said communication  
2 channel is between a mobile station and a base station, wherein said

controller is configured for said controlling by adjusting a frame error rate set  
4 point, at said mobile station, of a power control outer loop, wherein said power  
control outer loop is operating to control power level of a signal transmitted  
6 from said mobile station.

23. The apparatus as recited in claim 16 wherein said communication  
2 channel is a dedicated control channel.

24. The apparatus as recited in claim 23, wherein said controller is  
2 configured for said controlling by modifying a code channel to pilot channel  
power ratio associated with a traffic channel.

25. The apparatus as recited in claim 24 wherein said controller is  
2 configured using said modified code channel to pilot channel power ratio to  
control power level of said dedicated control channel.

26. The apparatus as recited in claim 16 wherein said controller is  
2 configured for said controlling by adjusting a target power level of a pilot  
channel for controlling power level of said communication channel.

27. The apparatus as recited in claim 26 wherein said communication  
2 channel is between a mobile station and a base station, further comprising:  
a transmitter in said base station configured for communicating said  
4 adjusted target power level of said pilot channel to a receiver in said mobile  
station.

28. The apparatus as recited in claim 26 wherein said communication  
2 channel is between a mobile station and a base station, wherein said pilot  
channel originates from said mobile station.

29. The apparatus as recited in claim 16 wherein said controller is  
2 configured for said controlling by adjusting a power level of a power control  
sub-channel.

30. The apparatus as recited in claim 29 wherein said communication  
2 channel is between a mobile station and a base station, wherein said power  
control sub-channel originates from said base station.



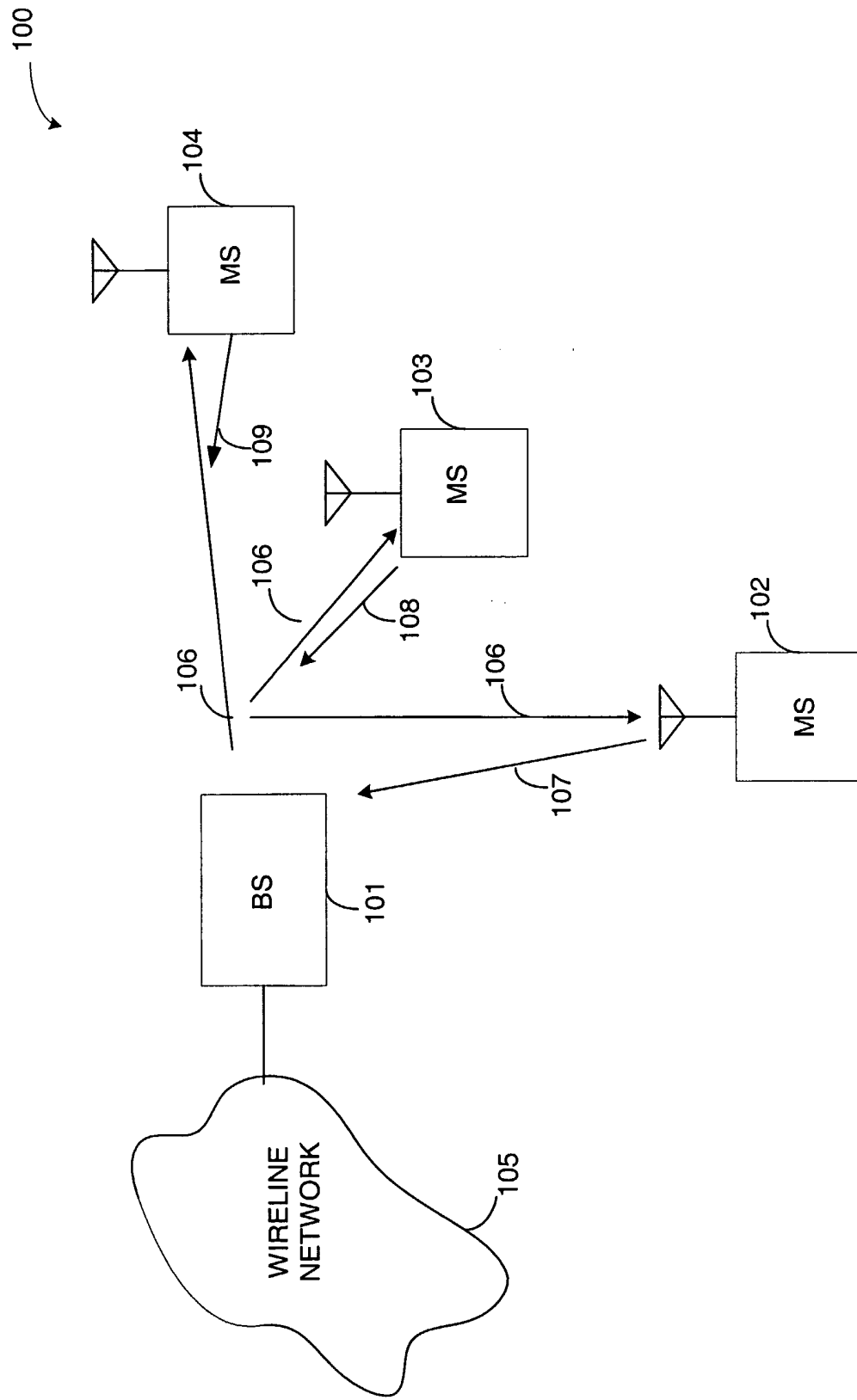

FIG. 1

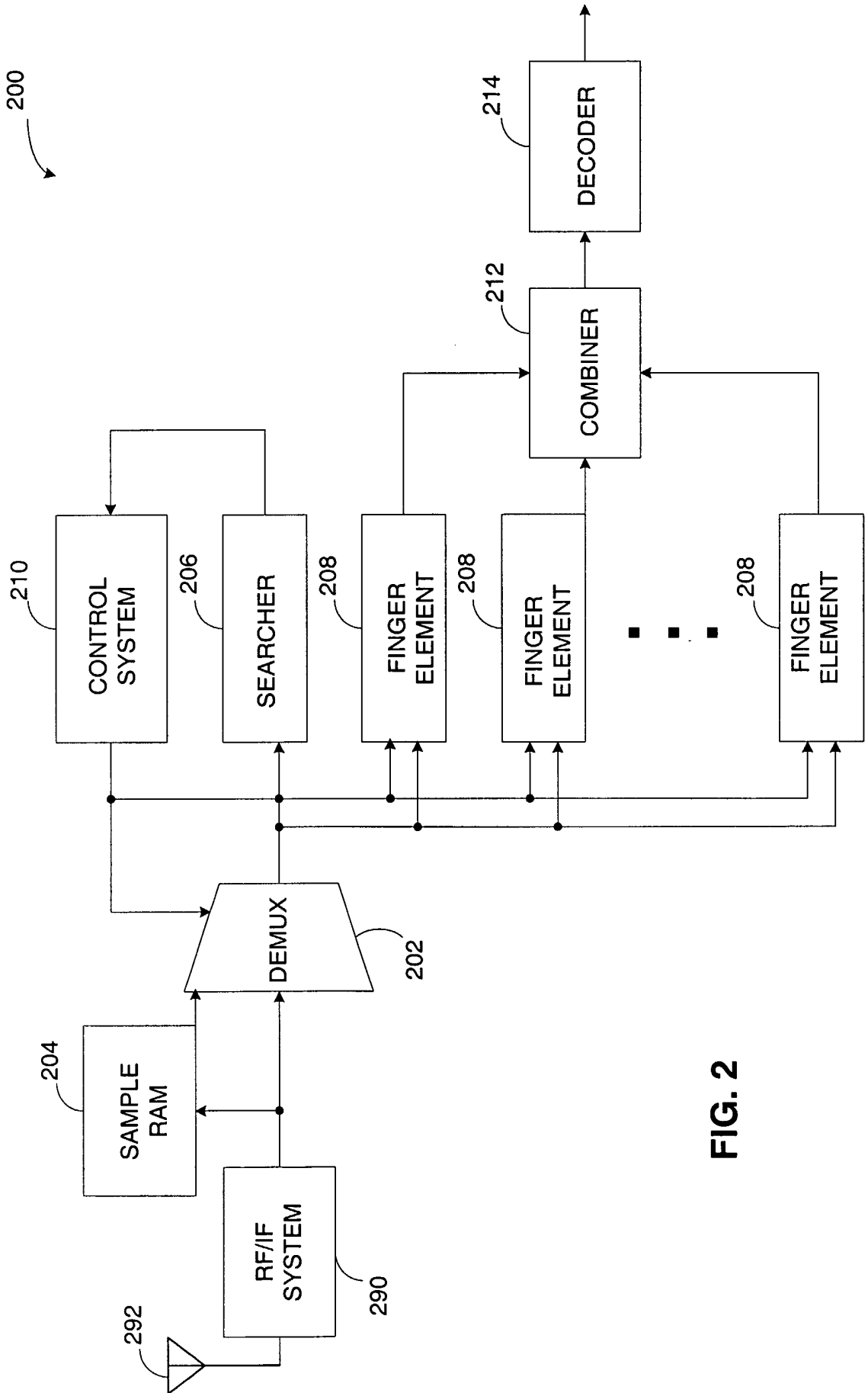

FIG. 2

300

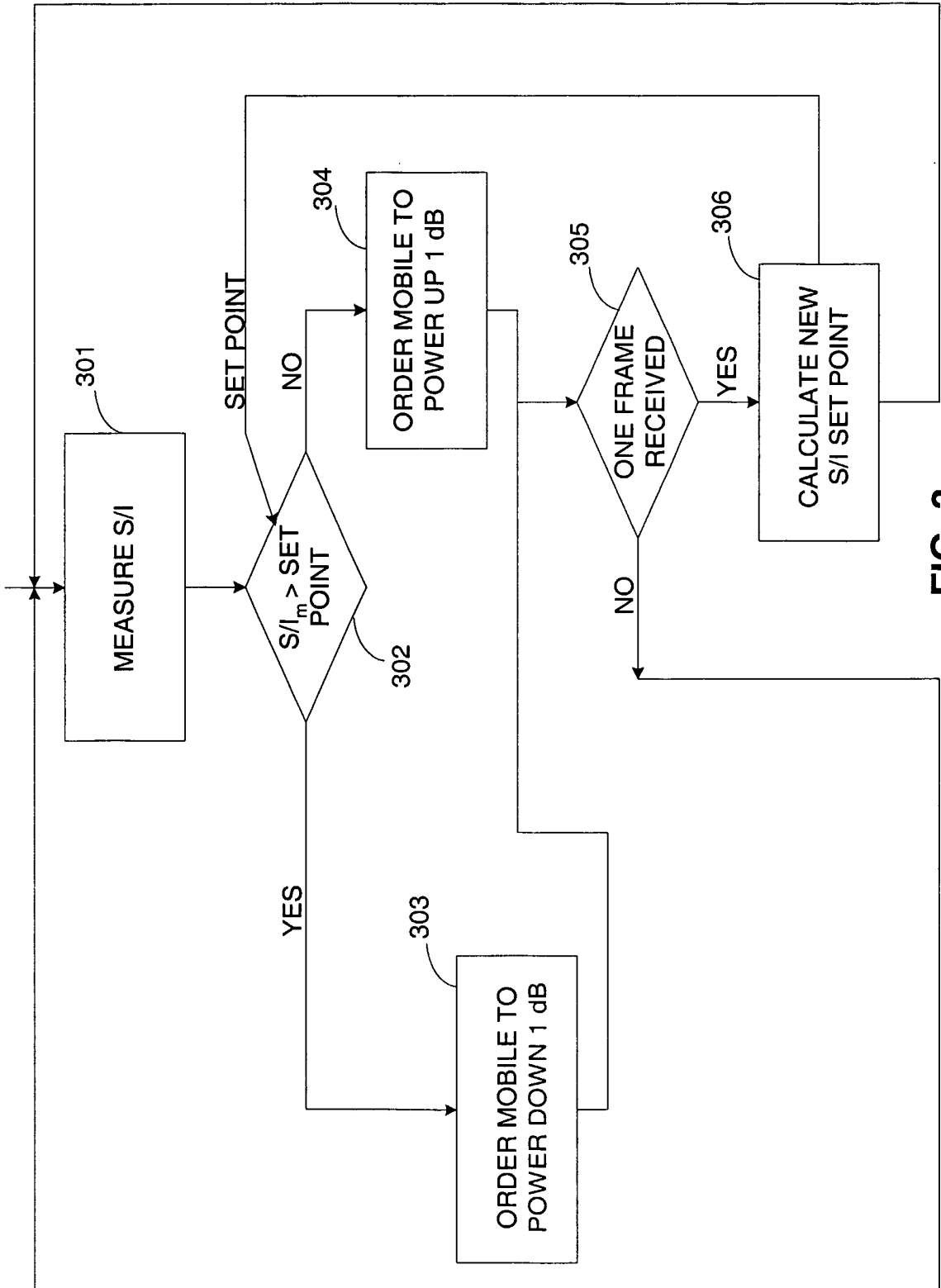

FIG. 3

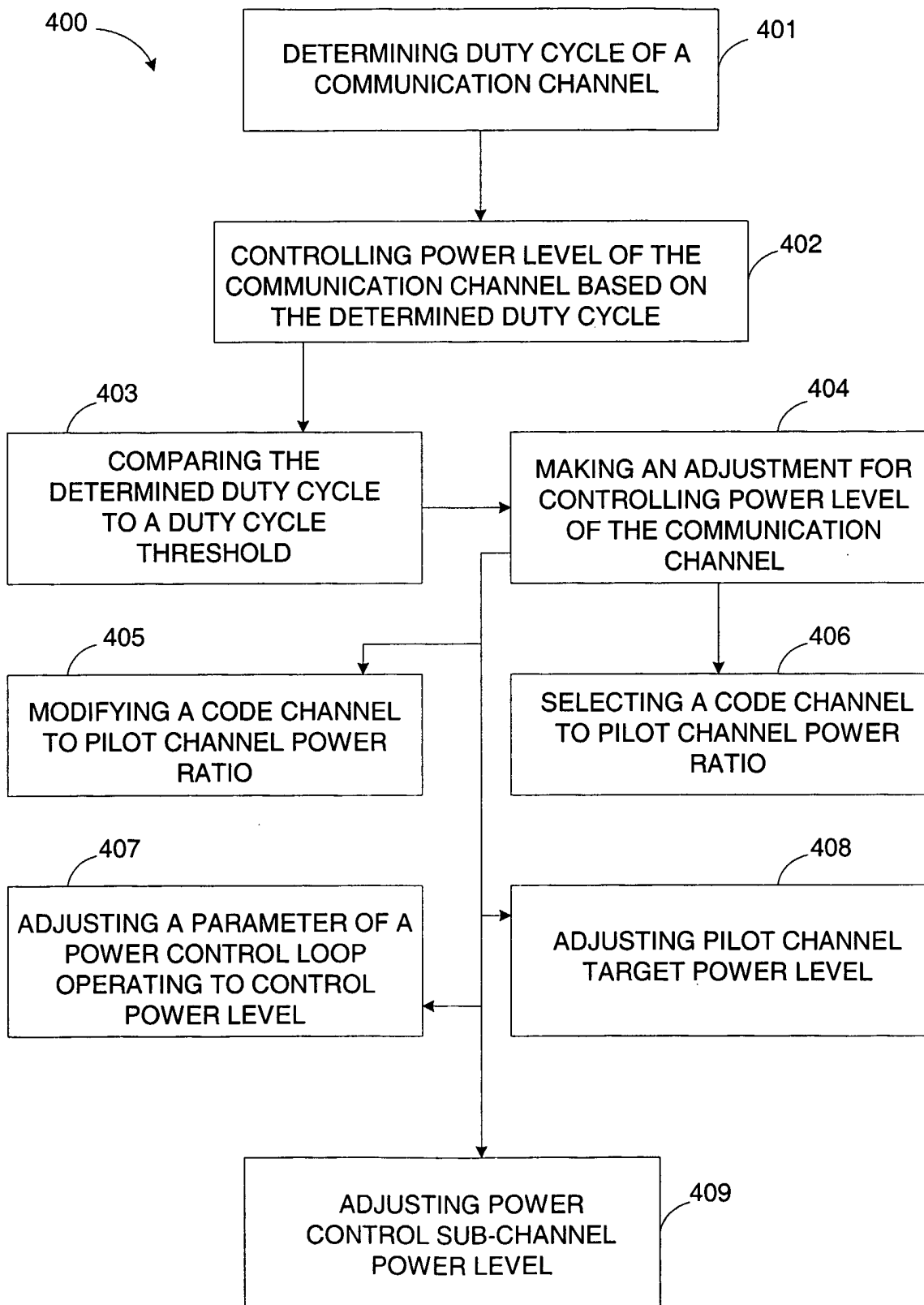

FIG. 4