



- (51) International Patent Classification: *B41J 29/13* (2006.01)
- (21) International Application Number: PCT/US2014/056499
- (22) International Filing Date: 19 September 2014 (19.09.2014)
- (25) Filing Language: English
- (26) Publication Language: English
- (30) Priority Data: 14/033,045 20 September 2013 (20.09.2013) US
- (71) Applicant: **VELTEK ASSOCIATES, INC.** [US/US]; 15 Lee Boulevard, Malvern, Pennsylvania 19355 (US).
- (72) Inventor: **VELLUTATO, JR., Arthur L.**; 10 Steeplechase Lane, Malvern, Pennsylvania 19355 (US).
- (74) Agent: **WEISSMAN, Peter S.**; BLANK ROME LLP, 600 New Hampshire Avenue NW, Washington, District of Columbia 20037 (US).
- (81) Designated States (*unless otherwise indicated, for every kind of national protection available*): AE, AG, AL, AM, AO, AT, AU, AZ, BA, BB, BG, BH, BN, BR, BW, BY, BZ, CA, CH, CL, CN, CO, CR, CU, CZ, DE, DK, DM, DO, DZ, EC, EE, EG, ES, FI, GB, GD, GE, GH, GM, GT, HN, HR, HU, ID, IL, IN, IR, IS, JP, KE, KG, KN, KP, KR, KZ, LA, LC, LK, LR, LS, LU, LY, MA, MD, ME, MG, MK, MN, MW, MX, MY, MZ, NA, NG, NI, NO, NZ, OM, PA, PE, PG, PH, PL, PT, QA, RO, RS, RU, RW, SA, SC, SD, SE, SG, SK, SL, SM, ST, SV, SY, TH, TJ, TM, TN, TR, TT, TZ, UA, UG, US, UZ, VC, VN, ZA, ZM, ZW.
- (84) Designated States (*unless otherwise indicated, for every kind of regional protection available*): ARIPO (BW, GH, GM, KE, LR, LS, MW, MZ, NA, RW, SD, SL, ST, SZ, TZ, UG, ZM, ZW), Eurasian (AM, AZ, BY, KG, KZ, RU,

[Continued on next page]

(54) Title: PORTABLE CLEANROOM PRINTING CABINET

(57) Abstract: A portable printing cabinet includes a housing having a substantially enclosed interior. A printing device is located within the interior of the housing. A paper tray is located on an outer surface on an outside of the housing, and a paper guide extends from the printing device to the paper tray and is configured to transfer printed paper from the printing device within the housing to the paper tray at the outside of the housing.

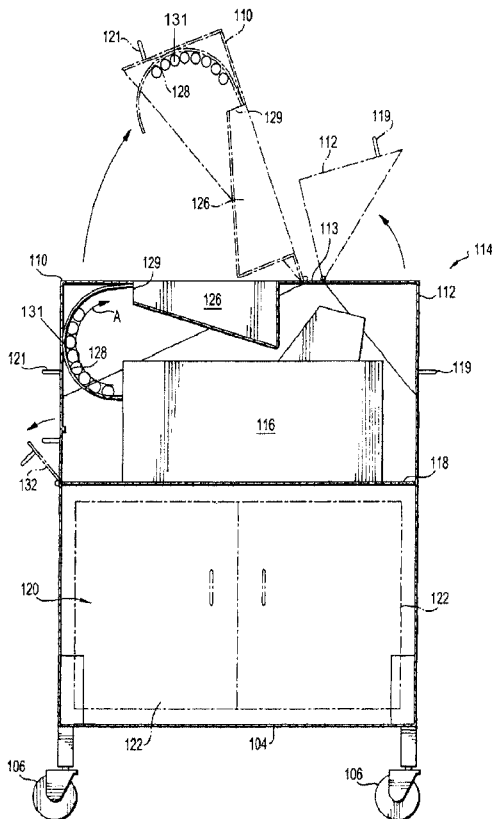

FIG. 2

WO 2015/042364 A1

TJ, TM), European (AL, AT, BE, BG, CH, CY, CZ, DE, **Published:**
DK, EE, ES, FI, FR, GB, GR, HR, HU, IE, IS, IT, LT, — *with international search report (Art. 21(3))*
LU, LV, MC, MK, MT, NL, NO, PL, PT, RO, RS, SE,
SI, SK, SM, TR), OAPI (BF, BJ, CF, CG, CI, CM, GA,
GN, GQ, GW, KM, ML, MR, NE, SN, TD, TG).

PORTABLE CLEANROOM PRINTING CABINET

Field of the Invention

[0001] The invention relates to a portable printing cabinet for use in a sterile environment. In particular, the invention provides a multi-compartment printing unit that can be used in a cleanroom without introducing outside contaminants such as particulates and microorganisms.

Background of the Invention

[0002] Sterile “cleanroom” environments demand that any person or item entering the room be free of a certain level of contaminants. Sterilized environments are most commonly designed for use in manufacturing facilities and medical research and treatment facilities in the pharmaceutical, biotechnology, and healthcare industries, to name a few. Sterile cleanroom environments may be classified under a variety of classification schemes, including the International Organization of Standardization (“ISO”) Cleanroom Standards, whereby the highest level of sterilization is an ISO 1 cleanroom, and normal ambient air (no sterilization) is classified as ISO 9. The ISO standards correspond to the allowed number of particles having a minimum particle size per cubic meter. For example, an ISO 5 cleanroom allows the following: a maximum of 100,000 particles with a particle size greater than 0.1 μm; a maximum of 23,700 particles greater than 0.2 μm; a maximum of 10,200 particles greater than 0.3 μm; a maximum of 3,520 particles greater than 0.5 μm; a maximum of 832 particles greater than 1 μm; and a maximum of 29 particles greater than 5 μm.

[0003] A variety of products are utilized inside cleanroom environments, including paper and paper products used to document manufacturing and testing records within the controlled areas.

Such paper products include, but are not limited to, forms, logbooks, tags and batch records. All of these documents are necessary to detail the manufacturing and testing processes so as to ensure that proper procedures are followed and results are documented. Indeed, these documents are subject to review by regulatory agencies, such as the U.S. Food and Drug Administration, and represent the mechanism by which such agencies can review the manufacturing and testing process details after the manufacture, testing, or handling of a drug product, for example, to assure patient safety.

[0004] However, paper and paper products are a significant contamination source due to shedding fibers, particulates and microorganisms (e.g., bacillus and mold). About 40% of paper products used in sterile environments are standard documents that can be pre-printed, packaged and sterilized by known means. However, the remainder of the documents introduced into sterile environments cannot be pre-printed, sterilized and packaged in a timely fashion. Their preparation requires information that is not readily available until days, or even hours, before the manufacturing or testing is to begin. In some instances, they must be prepared while manufacturing and/or testing is underway. Because of this, these documents are forced to be brought into sterilized areas without prior treatment for the reduction of shedding fibers, particulates and microorganisms. Thus, they represent a significant contamination source.

[0005] To solve this problem, the invention provides for a portable cleanroom printing cabinet which allows documents to be printed in sterile environments without the introduction of any outside contaminants.

Summary of the Invention

[0006] Accordingly, the invention provides a portable printing cabinet, including a housing which has a substantially enclosed interior, a printing device located within the interior of the housing, a paper tray located on an outer surface on an outside of the housing, and a paper guide extending from the printing device to the paper tray and which is configured to transfer printed paper from the printing device within the housing to the paper tray at the outside of the housing.

[0007] The invention also provides a portable printing cabinet, including a stainless steel housing having a substantially enclosed interior and a bottom surface, a plurality of wheels fixed to the bottom surface of the housing, at least one door fixed to the housing, an interior shelf located within the housing which defines an upper portion and a lower portion of the cabinet, a printing device located on the interior shelf, two adjacent hinged covers fixed to the housing, a paper tray located on an outer surface on an outside of the housing, a paper guide which extends from the printing device to the paper tray and which is configured to transfer printed paper from the printing device within the housing to the paper tray at the outside of the housing, two air filtration units located within the housing, each having vents positioned on the housing, a power outlet located on the housing, a battery located within the housing and which is electrically connected to the power outlet, and at least one data connection port located on the housing.

Brief Description of the Drawings

[0008] A more complete appreciation of the invention and many of the attendant advantages thereof will be readily obtained as the same becomes better understood by reference to the following detailed description when considered in connection with the accompanying drawings, wherein:

[0009] FIG. 1 is a perspective view of a portable printing cabinet in accordance with an exemplary embodiment of the invention;

[0010] FIG. 2 is a front sectional view of the portable printing cabinet illustrated in FIG. 1 taken along line 2-2; and

[0011] FIG. 3 is a side elevational view of the portable printing cabinet illustrated in FIG. 1.

Detailed Description

[0012] Referring to FIGS. 1-3, the portable printing cabinet 100 of the invention allows the printing of documents within a controlled, cleanroom environment onto sterilized paper at high speeds. This cabinet reduces or eliminates the presence of bioburden (e.g., microorganisms such as bacillus and mold) on printed documents. The printing cabinet 100 further assures that particulates and shedding fibers from the paper is minimized or eliminated. The printing cabinet 100 of the invention may be used in any ISO level controlled area, including cleanrooms at an ISO 5 level or lower.

[0013] As shown in FIG. 1, the printing cabinet 100 generally includes a housing 102 having at least four sides and a bottom 104. In the embodiment shown, the four sides are formed of thin rectangular-shaped panels and include a left side 130, front side 124, right side 134, and back side 135. The sides 124, 130, 134 and 135 are preferably joined with the bottom 104 of the housing 102 to form a substantially rectangular box-shaped cabinet 100. Preferably, the housing 102 forms an enclosure that defines an interior space. Cross-member 113 may connect the front side 124 of the housing 102 to the back side 135 of the housing 102. The cabinet 100 may be supported by any structure known in the art. As shown in FIG. 1, the cabinet 100 is supported by a plurality of wheels 106 fixed to the bottom 104. The use of wheels 106 allows the cabinet 100 to be moved out of the cleanroom when necessary for cleaning or sterilization treatment. Legs may also be used if the cabinet 100 does not need to be moved from one location to another.

[0014] The housing 102 may be formed of any durable material which can store a printing device and other items, and which prevents the passage of fluids or air into the interior of the cabinet 100. Indeed, the housing 102 preferably forms a sealed unit (with covers 110 and 112) such that contaminants cannot escape. According to one embodiment, the entire housing 102 is

formed of stainless steel. According to another embodiment, other durable metals or plastic materials may be used. Metals are preferred such that sterilization of the unit can be performed by an autoclave or other similar devices.

[0015] Referring now to FIG. 2, a cross-section is shown of the printing cabinet 100 taken along line 2-2 of FIG. 1. An interior shelf 118 may be provided that divides the cabinet 100 into an upper portion 114 and a lower portion 120. In one embodiment, the interior shelf 118 is welded to sides 124, 130, 134 and 135 of the housing 102 to form a complete assembly. The upper portion 114 houses a printing device 116, which can be placed on the interior shelf 118. Any printing device known in the art may be used. High-grade printers which emit the lowest level of particulates, reduce shedding, and reduce ink droplet release, are preferred. According to one embodiment, the CDT 1600S printer manufactured by Colordyne Technologies LLC of Brookfield, Wisconsin may be used. However, it will be appreciated that any suitable printer can be utilized within the scope of the invention.

[0016] The upper portion 114 of the cabinet 100 may also house an air filtration unit 133 having a fan aligned with exterior vents 140 positioned on at least one side of the housing 102 (see FIG. 1). Any filtration unit known in the art may be used, though preferable that the unit achieves a filtration rate of 99.9997%. More specifically, the unit 133 must filter air from the interior of the cabinet 100 at a rate of 99.9997% with respect to 0.5 micron particles. According to one embodiment, a high-efficiency particulate air (“HEPA”) filtration unit may be used. The fan of the air filtration unit 133 blows air out of the cabinet through the filter. This maintains the cabinet 100 under negative pressure, via the exterior vents 140, such that the risk of transmission of particles to the exterior environment is minimized. Thus, if a door 122 or 132, or a cover 110 or 112, is opened, the fan will suck air into the housing interior, preventing particles from

escaping. In addition, the interior shelf 118 may have vents (not shown) which permit equalization of the pressure in the cabinet 100 between the upper portion 114 and the lower portion 120.

[0017] According to a preferred embodiment, at least one hinged cover is fixed to the housing 102 of the cabinet 100 so as to enclose the upper portion 114 and still allow for easy access to the printing device 116. As shown in FIG. 1, the upper portion 114 is enclosed by two adjacent hinged covers 110 and 112 having a generally triangular shape. Specifically, hinged covers 110 and 112 may each have angled edges 123 which engage the front side 124 and back side 135 of the housing 102. The front cover 110 may be hinged to cross-member 113 of the housing 102 along one longitudinal side 115. Any method of hinging one member to another member may be used, including piano style mechanical hinges or the inclusion of a polymer strip (e.g., polypropylene) between the cover 110 and the cross-member 113 along side 115. While the air filtration unit 133 adequately maintains the interior of the cabinet 100 under negative pressure so as to minimize the risk of contamination, gaskets or rubber seals may optionally be utilized between the hinged covers 110 and 112 and the housing 102 (on any side) to further ensure contamination protection.

[0018] The front cover 110 may include a paper tray 126 on an outer surface for receiving printed documents. In another embodiment, the paper tray 126 need not be on the front cover 110, but may be separate from the housing 102 and attached thereto. Alternatively, the printed paper may be ejected from an opening in the housing 102 located on any side adjacent to the end of the printing device 116.

[0019] As seen in FIG. 2, the printing device 116 may include a paper guide 128 extending from an end thereof. The paper guide 128 may be a C-shaped paper dispensing guide having a

plurality of rollers 131 along its length. In one embodiment, the paper guide 128 is a half circle with a radius of between 3 and 8 inches, such that a variety of paper sizes may be accommodated. When the printed paper is expelled from the printing device 116, it is moved along by the rollers 131 on the paper guide 128 in direction "A." The paper guide 128 guides the paper upward to be received in the paper tray 126, which is then accessible without needing to lift the front cover 110 to access the printing device 116. In this way, the paper guide 128 transfers the paper from the printing device 116, inside of the housing 102, to the paper tray 126, outside of the housing 102. The printed paper should be ejected from the printing device 116 with a force sufficient to push the paper along the rollers 131 of the paper guide 128 and deposited into paper tray 126 above. In one embodiment, a gear-driven assembly having a motor (not shown) may be used to rotate the rollers to thereby push or pull the printed paper along the paper guide 128. The front cover 110 includes an opening 129 in communication with the paper tray 126 so as to allow the printed paper to pass through. Specifically, the paper guide 128 is connected to the top of the opening 129 in the front cover 110 such that the paper can be deposited into the paper tray 126 on top of any paper previously printed. The front cover 110 only needs to be lifted if the printing device 116 experiences a paper jam or lodged paper needs to be removed from the paper guide 128. The front cover 110 may include a handle 121 designed for use by an individual wearing a protective glove.

[0020] The rear cover 112 may be configured similarly to the front cover 110. The rear cover 112 may be used to feed paper into the printing device 116. Specifically, the rear cover 112 may be hinged to cross-member 113 of the housing 102 along a longitudinal side 117 opposite the side connected to the front cover 110. The hinging mechanism may be similar to those used with the front cover 110, as discussed above. The rear cover 112 may have a handle

119, which is designed for use by an individual wearing a protective glove. The opened first and second covers 110 and 112, respectively, are illustrated in FIG. 2.

[0021] The left side 130 of the housing 102 may include one or more doors 132 (one is illustrated in FIG. 1) for access to the printing device 116 and upper portion 114 of the printing cabinet 100. Specifically, while not limited to such an embodiment, the door 132 may be used for printer cartridge replacement. Because high-quality printing devices are preferred according to the invention, numerous printing cartridges may need to be used and replaced often. The user may access the printing device 116 to replace printing cartridges by opening the door 132, as shown in FIG. 2. While the door 132 is depicted on the left side 130 of the cabinet 100 in FIGS. 1 and 2, it may be positioned on any side of the cabinet 100 which allows access to the printing device 116 (e.g., front side 124). Like the front and rear covers 110 and 112, respectively, gaskets or rubber seals may optionally be utilized between door 132 and the housing 102 to further ensure contamination protection.

[0022] As shown in FIG. 3, the right side 134 of the housing 102 may include ports for the connection of a data cable and/or power cable. Specifically, two data connection ports 136 and one power outlet 138 are shown, although any number of ports may be present for various purposes. According to another embodiment, the ports 136 and outlet 138 may be provided on any side of the cabinet 100. The data connection ports 136 and outlet 138 may be present on both the outside of the housing 102 (as shown in FIG. 3) and the inside of the housing 102 for connection to the printing device 116 or any other devices inside the cabinet 100. Specifically, the printing device 116 and other electronics may be plugged into the power outlet 138, for example, from the inside of the housing 102. From the outside of the housing 102, an AC electrical power cord, which is plugged into a power source, may then be plugged into power

outlet 138. As shown in FIG. 3, the power outlet 138 on the outside of the housing 102 is a male connector (with two or three prongs) that is inset into the housing 102 so as to protect it from damage. At the interior of the housing 102, outlet 138 is a female receptacle to accept the power plugs from the printing device 116 and other electrical components. The placement of ports 136 and power outlet 138 on the exterior surface of the cabinet 100 are advantageous in that the doors 122 (discussed below) need not be opened in order to plug and unplug the printing device 116, such as when the cabinet 100 is moved from one location to another.

[0023] As a portable unit, the cabinet 100 may operate on either AC electrical power (i.e., 110V AC in the U.S. or 220V AC globally) or battery power. In one embodiment, a battery (not shown) is located within the lower portion 120 of the cabinet 100 and is electrically connected to the power outlet 138. The battery may be of a type that would power the printing device 116 and one or more air filtration units 133 for a period of up to at least six hours. When not in use, the battery may be charged via electrical power delivered through the outlet 138.

[0024] The lower portion 120 of the printing cabinet 100 is located below the interior shelf 118 and may be used for storage of miscellaneous items such as sterilized paper. The lower portion 120 may be accessible to a user via one or more doors 122 fixed to any of the side(s) of the cabinet 100. As shown in FIGS. 1 and 2, the lower portion 120 has two doors 122 fixed to the front side 124 of the cabinet 100, although more than two doors may be included. The lower portion 120 may also house an air filtration unit (not shown) similar to the filtration unit 133 housed in the upper portion 114. As discussed herein, gaskets or seals may be utilized between the outer periphery of the door(s) 122 and the housing 102 to further ensure contamination protection.

[0025] In an alternative embodiment (not shown), the housing 102 is substantially enclosed,

such that it has no openings or doors, except opening 129 where the printed paper passes into the paper tray 126. The presence of the air filtration unit 133 within the housing 102 maintains negative pressure within the cabinet 100, such that protection against contamination is ensured.

[0026] In practice, the printing device 116 and air filtration unit(s) 133 may be controlled via a wireless connection or hard wire connection to a network. According to one embodiment where hard wiring is used, a USB cable or an Ethernet cable may be connected from the PC to the ports 136, and then another cable may be connected from ports 136 to the printing device 116 on the inside of the housing 102. In another embodiment, any known wireless communication methods may be used, including, but not limited to, WiFi and Bluetooth[®] capabilities. Control of the printing device 116 may be accomplished within the cleanroom by any known wireless or wired devices, including, but not limited to, a network computer, an iPad[®], a PC, or a laptop computer. When it receives a signal, the printing device 116 prints the required document and expels it into the paper tray 126 for collection by a user. The motor can activate the rollers 131, for instance, when the printing device 116 is activated.

[0027] To further ensure the sterility of the cleanroom environment, the printing device 116 prints onto pre-sterilized paper. Any methods of sterilizing the paper known to one skilled in the art may be used, including, but not limited to, steam, heat, chemical treatment, or gamma irradiation. Preferably, a non-shedding paper product is used. In one embodiment, a plastic, non-shedding printing medium, such as Teslin[®] manufactured by PPG Industries of Pittsburgh, Pennsylvania, may be used. However, any suitable paper or printing medium can be used. The paper or printing medium may be provided on rolls at a predetermined length, or it may be provided as cut sheets prepared in ream. As set forth above, this paper may be stored in the lower portion 120 of the cabinet 100 when not in use.

[0028] The printing cabinet 100 is fully portable. All contents located within the cabinet 100 (e.g., printing device 116, air filtration unit 133) are enclosed within the housing 102. The printing cabinet 100 can be wheeled to other locations and plugged into any standard AC power source.

[0029] Although this invention has been described in connection with specific forms and embodiments thereof, it will be appreciated that various modifications other than those discussed above may be resorted to without departing from the spirit or scope of the invention. For example, equivalent elements may be substituted for those specifically shown and described, certain features may be used independently of other features, and in certain cases, particular locations of elements may be reversed or interposed, all without departing from the spirit or scope of the invention as defined in the appended Claims.

What is claimed:

1. A portable printing cabinet, comprising:
 - a housing having a substantially enclosed interior;
 - a printing device located within the interior of said housing;
 - a paper tray located on an outer surface on an outside of the housing; and
 - a paper guide extending from the printing device to the paper tray and configured to transfer printed paper from the printing device within the housing to the paper tray at the outside of the housing.
2. The portable printing cabinet of claim 1, further comprising at least one hinged cover fixed to the housing.
3. The portable printing cabinet of claim 1, further comprising an interior shelf located within the housing defining an upper portion of the housing and a lower portion of the cabinet.
4. The portable printing cabinet of claim 1, further comprising at least one air filtration unit located within the housing and having at least one vent positioned on the housing.
5. The portable printing cabinet of claim 4, wherein the at least one air filtration unit comprises a fan which forces air from the interior of the housing to the outside of the housing through the at least one vent.

6. The portable printing cabinet of claim 1, wherein the housing is made of stainless steel.
7. The portable printing cabinet of claim 1, further comprising a second hinged cover fixed to the housing adjacent to the first hinged cover.
8. The portable printing cabinet of claim 1, further comprising at least one door fixed to the housing.
9. The portable printing cabinet of claim 1, further comprising a second air filtration unit located within the housing and having vents positioned on the housing.
10. The portable printing cabinet of claim 1, further comprising a plurality of wheels fixed to a bottom surface of the housing.
11. The portable printing cabinet of claim 1, further comprising at least one data connection port located on the housing.
12. The portable printing cabinet of claim 1, further comprising a power outlet located on the housing.
13. The portable printing cabinet of claim 12, further comprising a battery located within the housing and being electrically connected to the power outlet.

14. A portable printing cabinet, comprising:
- a stainless steel housing having a substantially enclosed interior and a bottom surface;
 - a plurality of wheels fixed to the bottom surface of the housing;
 - at least one door fixed to the housing;
 - an interior shelf located within the housing defining an upper portion and a lower portion of the cabinet;
 - a printing device located on the interior shelf;
 - two adjacent hinged covers fixed to the housing;
 - a paper tray located on an outer surface on an outside of the housing;
 - a paper guide extending from the printing device to the paper tray and configured to transfer printed paper from the printing device within the housing to the paper tray at the outside of the housing;
 - two air filtration units located within the housing, each having vents positioned on the housing;
 - a power outlet located on the housing;
 - a battery located within the housing and being electrically connected to the power outlet;
- and
- at least one data connection port located on the housing.

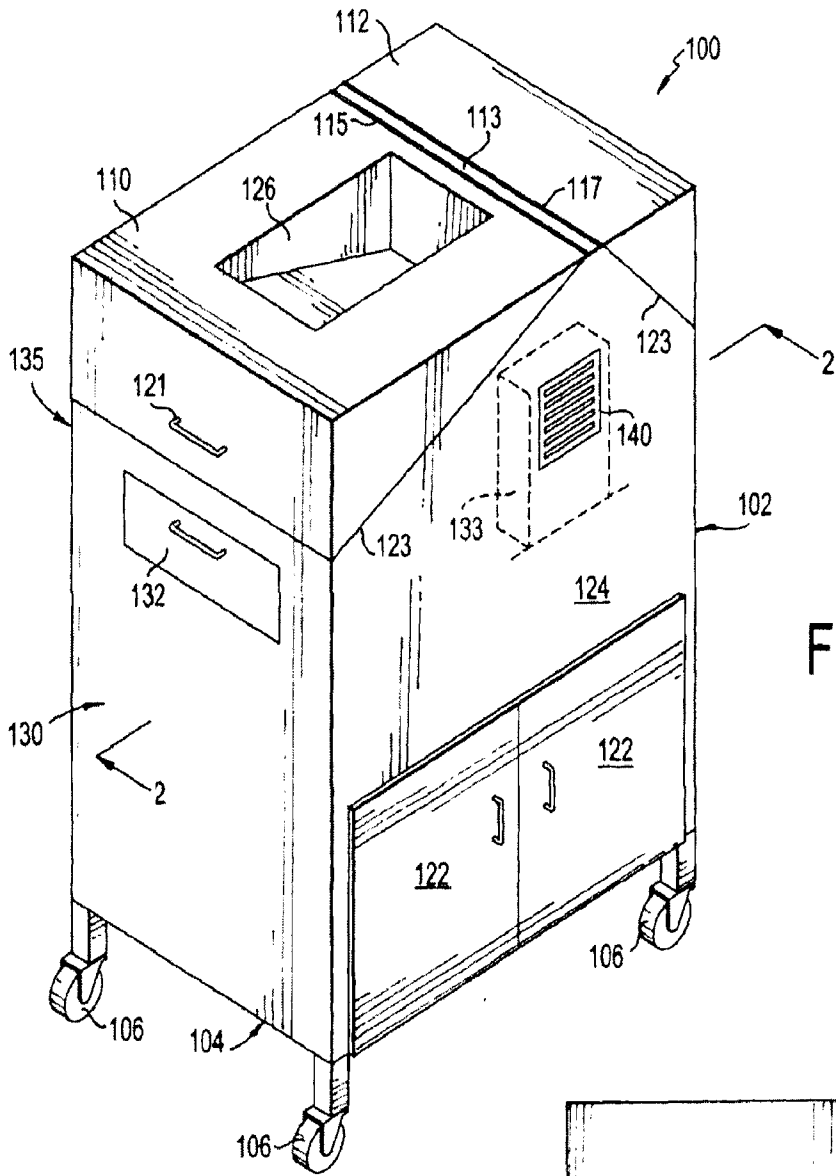

FIG. 1

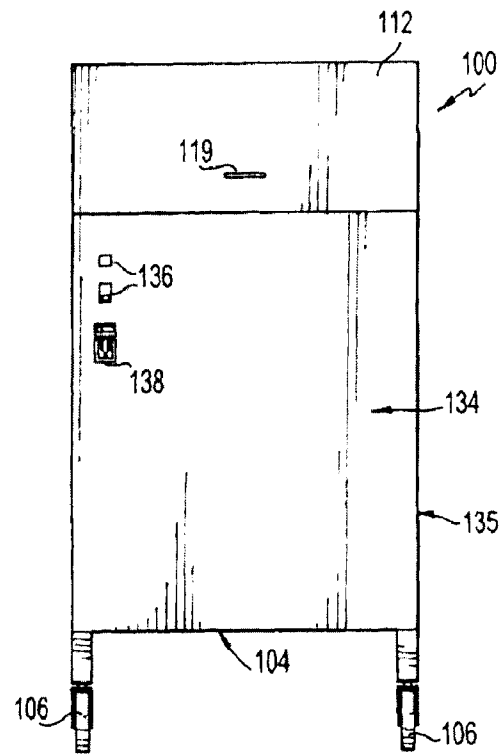

FIG. 3

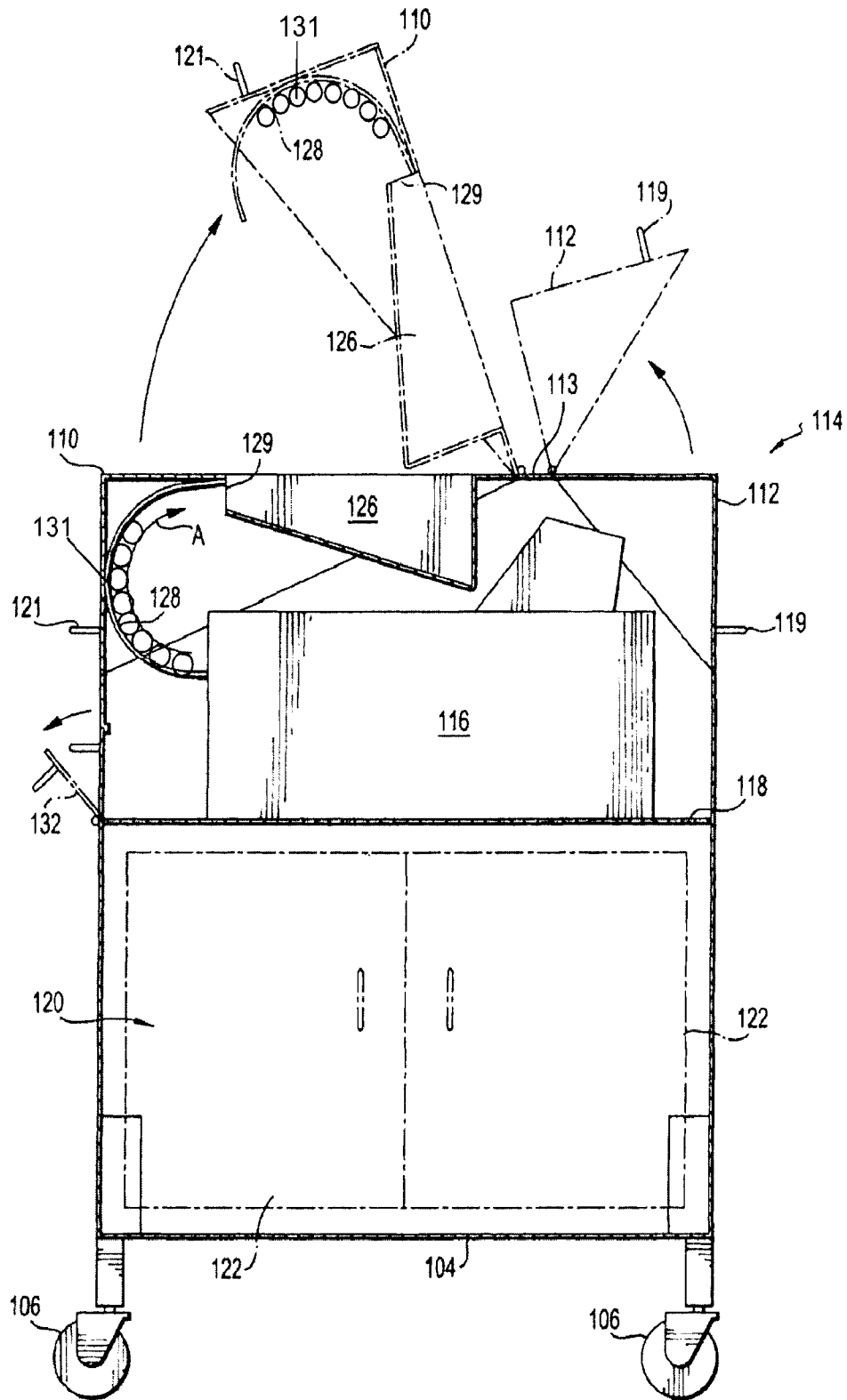

FIG. 2

INTERNATIONAL SEARCH REPORT

International application No.

PCT/US2014/056499

| <p>A. CLASSIFICATION OF SUBJECT MATTER IPC(8) - B41J 29/13 (2014.01) CPC - B41J 29/13 (2014.11) According to International Patent Classification (IPC) or to both national classification and IPC</p> | | | | | | | | | | | | | | | | | | | | |
|---|---|---|---|---|-----------------------|---|---|------------|-----|--|-------|---|--|-----------|---|--|----------------|---|---|----------|
| <p>B. FIELDS SEARCHED</p> <p>Minimum documentation searched (classification system followed by classification symbols) IPC(8) - B41J 3/36, 29/00, 29/12, 29/13; G03G 15/00 (2014.01) CPC - B41J 3/36, 29/00, 29/12, 29/13; G03G 15/00 (2014.11)</p> <p>Documentation searched other than minimum documentation to the extent that such documents are included in the fields searched USPC - 358/474, 498; 400/88, 613, 691, 693 (keyword delimited)</p> <p>Electronic data base consulted during the international search (name of data base and, where practicable, search terms used) PatBase, Google Patents, Google, YouTube. Search terms used: veltek, portable, printing, paper, housing, cleanroom</p> | | | | | | | | | | | | | | | | | | | | |
| <p>C. DOCUMENTS CONSIDERED TO BE RELEVANT</p> <table border="1" style="width:100%; border-collapse: collapse;"> <thead> <tr> <th style="width:10%;">Category*</th> <th style="width:70%;">Citation of document, with indication, where appropriate, of the relevant passages</th> <th style="width:20%;">Relevant to claim No.</th> </tr> </thead> <tbody> <tr> <td>X</td> <td>US 3,062,109 A (MAYO et al) 06 November 1962 (06.11.1962) entire document</td> <td>1, 2, 7, 8</td> </tr> <tr> <td>---</td> <td></td> <td>-----</td> </tr> <tr> <td>Y</td> <td></td> <td>3-6, 9-14</td> </tr> <tr> <td>Y</td> <td>US 5,056,331 A (LOTZ) 15 October 1991 (15.10.1991) entire document</td> <td>3-5, 9, 10, 14</td> </tr> <tr> <td>Y</td> <td>US 2011/0252897 A1 (SWENSON et al) 20 October 2011 (20.10.2011) entire document</td> <td>6, 11-14</td> </tr> </tbody> </table> | | | Category* | Citation of document, with indication, where appropriate, of the relevant passages | Relevant to claim No. | X | US 3,062,109 A (MAYO et al) 06 November 1962 (06.11.1962) entire document | 1, 2, 7, 8 | --- | | ----- | Y | | 3-6, 9-14 | Y | US 5,056,331 A (LOTZ) 15 October 1991 (15.10.1991) entire document | 3-5, 9, 10, 14 | Y | US 2011/0252897 A1 (SWENSON et al) 20 October 2011 (20.10.2011) entire document | 6, 11-14 |
| Category* | Citation of document, with indication, where appropriate, of the relevant passages | Relevant to claim No. | | | | | | | | | | | | | | | | | | |
| X | US 3,062,109 A (MAYO et al) 06 November 1962 (06.11.1962) entire document | 1, 2, 7, 8 | | | | | | | | | | | | | | | | | | |
| --- | | ----- | | | | | | | | | | | | | | | | | | |
| Y | | 3-6, 9-14 | | | | | | | | | | | | | | | | | | |
| Y | US 5,056,331 A (LOTZ) 15 October 1991 (15.10.1991) entire document | 3-5, 9, 10, 14 | | | | | | | | | | | | | | | | | | |
| Y | US 2011/0252897 A1 (SWENSON et al) 20 October 2011 (20.10.2011) entire document | 6, 11-14 | | | | | | | | | | | | | | | | | | |
| <p><input type="checkbox"/> Further documents are listed in the continuation of Box C. <input type="checkbox"/></p> | | | | | | | | | | | | | | | | | | | | |
| <p>* Special categories of cited documents:</p> <table style="width:100%;"> <tr> <td style="width:50%;"> <p>"A" document defining the general state of the art which is not considered to be of particular relevance</p> <p>"E" earlier application or patent but published on or after the international filing date</p> <p>"L" document which may throw doubts on priority claim(s) or which is cited to establish the publication date of another citation or other special reason (as specified)</p> <p>"O" document referring to an oral disclosure, use, exhibition or other means</p> <p>"P" document published prior to the international filing date but later than the priority date claimed</p> </td> <td style="width:50%;"> <p>"T" later document published after the international filing date or priority date and not in conflict with the application but cited to understand the principle or theory underlying the invention</p> <p>"X" document of particular relevance; the claimed invention cannot be considered novel or cannot be considered to involve an inventive step when the document is taken alone</p> <p>"Y" document of particular relevance; the claimed invention cannot be considered to involve an inventive step when the document is combined with one or more other such documents, such combination being obvious to a person skilled in the art</p> <p>"&" document member of the same patent family</p> </td> </tr> </table> | | | <p>"A" document defining the general state of the art which is not considered to be of particular relevance</p> <p>"E" earlier application or patent but published on or after the international filing date</p> <p>"L" document which may throw doubts on priority claim(s) or which is cited to establish the publication date of another citation or other special reason (as specified)</p> <p>"O" document referring to an oral disclosure, use, exhibition or other means</p> <p>"P" document published prior to the international filing date but later than the priority date claimed</p> | <p>"T" later document published after the international filing date or priority date and not in conflict with the application but cited to understand the principle or theory underlying the invention</p> <p>"X" document of particular relevance; the claimed invention cannot be considered novel or cannot be considered to involve an inventive step when the document is taken alone</p> <p>"Y" document of particular relevance; the claimed invention cannot be considered to involve an inventive step when the document is combined with one or more other such documents, such combination being obvious to a person skilled in the art</p> <p>"&" document member of the same patent family</p> | | | | | | | | | | | | | | | | |
| <p>"A" document defining the general state of the art which is not considered to be of particular relevance</p> <p>"E" earlier application or patent but published on or after the international filing date</p> <p>"L" document which may throw doubts on priority claim(s) or which is cited to establish the publication date of another citation or other special reason (as specified)</p> <p>"O" document referring to an oral disclosure, use, exhibition or other means</p> <p>"P" document published prior to the international filing date but later than the priority date claimed</p> | <p>"T" later document published after the international filing date or priority date and not in conflict with the application but cited to understand the principle or theory underlying the invention</p> <p>"X" document of particular relevance; the claimed invention cannot be considered novel or cannot be considered to involve an inventive step when the document is taken alone</p> <p>"Y" document of particular relevance; the claimed invention cannot be considered to involve an inventive step when the document is combined with one or more other such documents, such combination being obvious to a person skilled in the art</p> <p>"&" document member of the same patent family</p> | | | | | | | | | | | | | | | | | | | |
| <p>Date of the actual completion of the international search</p> <p>04 December 2014</p> | | <p>Date of mailing of the international search report</p> <p align="center">30 DEC 2014</p> | | | | | | | | | | | | | | | | | | |
| <p>Name and mailing address of the ISA/US</p> <p>Mail Stop PCT, Attn: ISA/US, Commissioner for Patents P.O. Box 1450, Alexandria, Virginia 22313-1450 Facsimile No. 571-273-3201</p> | | <p>Authorized officer:</p> <p align="center">Blaine R. Copenheaver</p> <p>PCT Helpdesk: 571-272-4300 PCT OSP: 571-272-7774</p> | | | | | | | | | | | | | | | | | | |