



US00D726349S

(12) **United States Design Patent**
Maxik et al.

(10) **Patent No.:** **US D726,349 S**

(45) **Date of Patent:** **** Apr. 7, 2015**

(54) **LUMINAIRE**

(75) Inventors: **Fredric S. Maxik**, Indialantic, FL (US);
David Henderson, Indialantic, FL (US);
Mark Penley Boomgaarden, Satellite
Beach, FL (US); **Addy S. Widjaja**, Palm
Bay, FL (US); **Emilio Flores**, Indian
Harbor, FL (US); **Shane Sullivan**,
Indialantic, FL (US); **Wei Sun**,
Indialantic, FL (US)

(73) Assignee: **Lighting Science Group Corporation**,
Satellite Beach, FL (US)

(**) Term: **14 Years**

(21) Appl. No.: **29/423,346**

(22) Filed: **May 31, 2012**

Related U.S. Application Data

(62) Division of application No. 29/376,702, filed on Oct.
11, 2010, now Pat. No. Des. 661,413.

(51) **LOC (10) Cl.** **26-06**

(52) **U.S. Cl.**

USPC **D26/2**

(58) **Field of Classification Search**

USPC D26/1-4; 313/313, 315, 316, 317, 318,
313/493; 315/52, 53, 56, 57, 58

See application file for complete search history.

(56) **References Cited**

U.S. PATENT DOCUMENTS

4,375,607 A 3/1983 Morton et al.
4,392,076 A 7/1983 Ishler et al.

(Continued)

FOREIGN PATENT DOCUMENTS

WO 2006118457 11/2006
WO 2008113837 A2 9/2008

OTHER PUBLICATIONS

SP-E27 LB60 Nicha / Cree LED Lamp, posted Dec. 18, 2008, http://www.diytrade.com/china/4/products/4950147/SP-E27_LB60_Nicha_Cree_LED_Lamp.html, accessed Jun. 30, 2009.

(Continued)

Primary Examiner — Marcus Jackson

(74) *Attorney, Agent, or Firm* — Cantor Colburn LLP

(57)

CLAIM

We claim, the ornamental design for a luminaire, as shown and described.

DESCRIPTION

FIG. 1 is a side plan view of a luminaire in accordance with an embodiment of the invention, the luminaire being symmetric about a center axis;

FIG. 2 is a top plan view of the luminaire of FIG. 1;

FIG. 3 is a bottom plan view of the luminaire of FIG. 1;

FIG. 4 is a first perspective view of the luminaire of FIG. 1; and,

FIG. 5 is a second perspective view of the luminaire of FIG. 1.

The degree of transparency or opaqueness of the lens of the luminaire forms no part of the claimed design. The lens of the claimed luminaire may have facets, lenslets or other treatments.

The dash-dot-dot lines shown between the heat sink portion and base portion in FIGS. 1, and 3-5, indicates that the heat sink portion may be of any length.

The phantom lines shown in FIGS. 1-5 are environmental and not part of the claimed design.

The color and shading of the luminaire forms no part of the claimed design, the luminaire according to the claimed design may be any color or combination of colors.

The surface treatment of the luminaire forms no part of the claimed design, the luminaire of the claimed design may have any surface treatment.

References to “side”, “top” and “bottom” in the figure descriptions are not meant to require certain in-use orientation; a luminaire according to the claimed design may be used in any orientation.

1 Claim, 5 Drawing Sheets

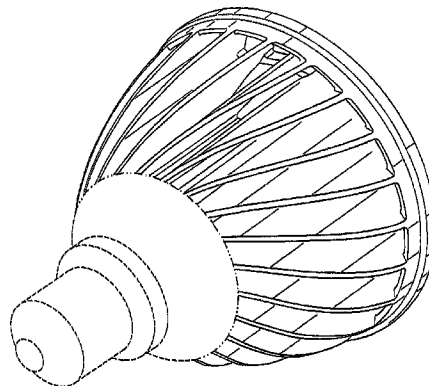

(56)

References Cited

U.S. PATENT DOCUMENTS

D271,424 S	11/1983	Young et al.	
D284,792 S	7/1986	Thiry et al.	
D307,805 S *	5/1990	Noe	D26/2
D321,260 S *	10/1991	Bowman	D26/2
D321,762 S	11/1991	Mujahid et al.	
D355,495 S	2/1995	Matsumura et al.	
5,458,505 A	10/1995	Prager	
D391,006 S	2/1998	Yang	
5,791,769 A	8/1998	Yang	
D470,610 S	2/2003	Bobel	
6,515,433 B1	2/2003	Ge et al.	
D480,486 S	10/2003	Kakuno et al.	
6,655,823 B2	12/2003	Chang	
6,786,625 B2	9/2004	Wesson	
D497,439 S	10/2004	Shaw et al.	
6,848,812 B1	2/2005	Hsieh	
D508,575 S	8/2005	Buschmann et al.	
D516,229 S	2/2006	Tang	
D527,119 S	8/2006	Maxik et al.	
D528,227 S	9/2006	Chou et al.	
D528,673 S	9/2006	Maxik et al.	
D531,741 S	11/2006	Takahashi	
D534,665 S	1/2007	Egawa et al.	
D538,950 S	3/2007	Maxik	
D538,951 S	3/2007	Maxik et al.	
D538,952 S	3/2007	Maxik et al.	
D541,957 S	5/2007	Wang	
D542,943 S	5/2007	Wang	
D545,457 S	6/2007	Chen	
7,226,189 B2	6/2007	Lee et al.	
D546,980 S	7/2007	Lo	
D549,854 S	8/2007	Takahashi	
D560,286 S	1/2008	Maxik et al.	
D563,572 S	3/2008	Lukacs	
D566,300 S	4/2008	Lo	
7,367,688 B1	5/2008	Bucher et al.	
D570,504 S	6/2008	Maxik et al.	
D570,505 S	6/2008	Maxik et al.	
D572,385 S	7/2008	Mazzochette et al.	
7,434,964 B1	10/2008	Zheng et al.	
D581,554 S	11/2008	To et al.	
D581,583 S	11/2008	Peng	
7,448,772 B2	11/2008	Hampton	
D582,578 S	12/2008	Tsai et al.	
D584,428 S	1/2009	Li et al.	
D584,837 S	1/2009	Mazzochette et al.	
D586,497 S	2/2009	Wu et al.	
7,513,653 B1	4/2009	Liu et al.	
D592,766 S	5/2009	Zhu et al.	
D593,222 S	5/2009	To et al.	
D594,143 S	6/2009	Montagnat et al.	
D594,995 S	6/2009	Komar	
D595,893 S	7/2009	Maxik et al.	
D597,225 S	7/2009	Yoo	
D597,704 S	8/2009	Peng	
D599,041 S	8/2009	Yoo	
D600,850 S	9/2009	Maxik et al.	
D601,275 S	9/2009	Ho et al.	
D601,276 S	9/2009	Grajcar	
D601,277 S	9/2009	Grajcar	
D601,278 S	9/2009	Takahashi	
D601,279 S	9/2009	Ou et al.	
D607,586 S	1/2010	Ko	
D608,478 S	1/2010	Maxik et al.	
D610,271 S	2/2010	Bi	
D610,722 S	2/2010	Bi	
D612,956 S	3/2010	Moon	
D613,433 S	4/2010	Moon	
7,717,590 B1	5/2010	Li	
D617,915 S	6/2010	Wada et al.	
D618,369 S	6/2010	Lee et al.	
D620,153 S	7/2010	Wang et al.	
D621,973 S	8/2010	Grajcar	
D621,974 S	8/2010	Grajcar	
D623,777 S	9/2010	Moon et al.	
D623,778 S	9/2010	Moon et al.	
D623,779 S	9/2010	Wang et al.	
D624,214 S	9/2010	Thomas et al.	
D624,215 S	9/2010	Moon et al.	
D624,669 S	9/2010	Tsai	
D625,437 S	10/2010	Zhang et al.	
D626,260 S	10/2010	Wei	
D626,667 S	11/2010	Jonsson et al.	
D627,087 S	11/2010	Jonsson et al.	
D628,322 S	11/2010	Sakai et al.	
D628,720 S	12/2010	Wang	
D629,129 S	12/2010	Lin et al.	
D629,930 S	12/2010	Cotter et al.	
D630,347 S	1/2011	Pei et al.	
D634,031 S	3/2011	de Visser et al.	
D634,037 S	3/2011	Jeong et al.	
D635,105 S	3/2011	Maxik et al.	
D636,902 S	4/2011	Pei et al.	
D636,904 S	4/2011	Leahy et al.	
D640,820 S	6/2011	Hopper	
D645,988 S	9/2011	Taylor	
D646,409 S	10/2011	MacDonald et al.	
D648,041 S	11/2011	Mahler et al.	
D650,495 S	12/2011	Foo	
D652,564 S	1/2012	Maxik	
D654,192 S	2/2012	Maxik et al.	
D656,631 S	3/2012	Leahy et al.	
D658,791 S	5/2012	Maxik et al.	
D659,266 S	5/2012	Maxik et al.	
D662,627 S	6/2012	Pan	
D663,051 S	7/2012	Xu et al.	
D663,057 S	7/2012	Pan	
D663,446 S	7/2012	Maxik et al.	
D665,107 S	8/2012	Tu	
2006/0215408 A1	9/2006	Lee	
2007/0285926 A1	12/2007	Maxik	
2008/0253125 A1	10/2008	Kang et al.	
2009/0141500 A1	6/2009	Peng	
2009/0296402 A1	12/2009	Chang et al.	
2010/0027270 A1	2/2010	Huang et al.	
2010/0091487 A1	4/2010	Shin	

OTHER PUBLICATIONS

F.S. Maxik, "GU10 Lamp" Office Action mailed Mar. 16, 2011; U.S. Appl. No. 29/340,670, filed Jul. 23, 2009.

* cited by examiner

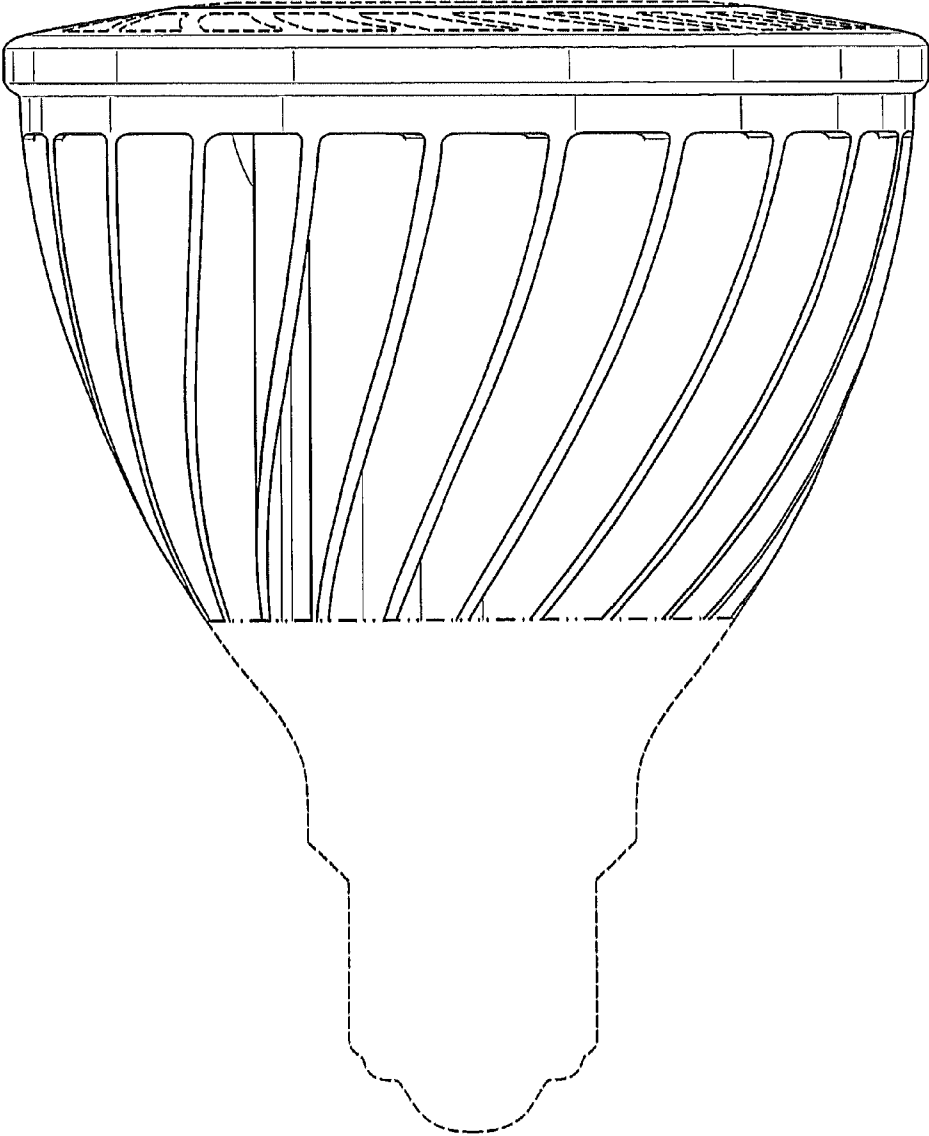

FIG. 1



FIG. 2

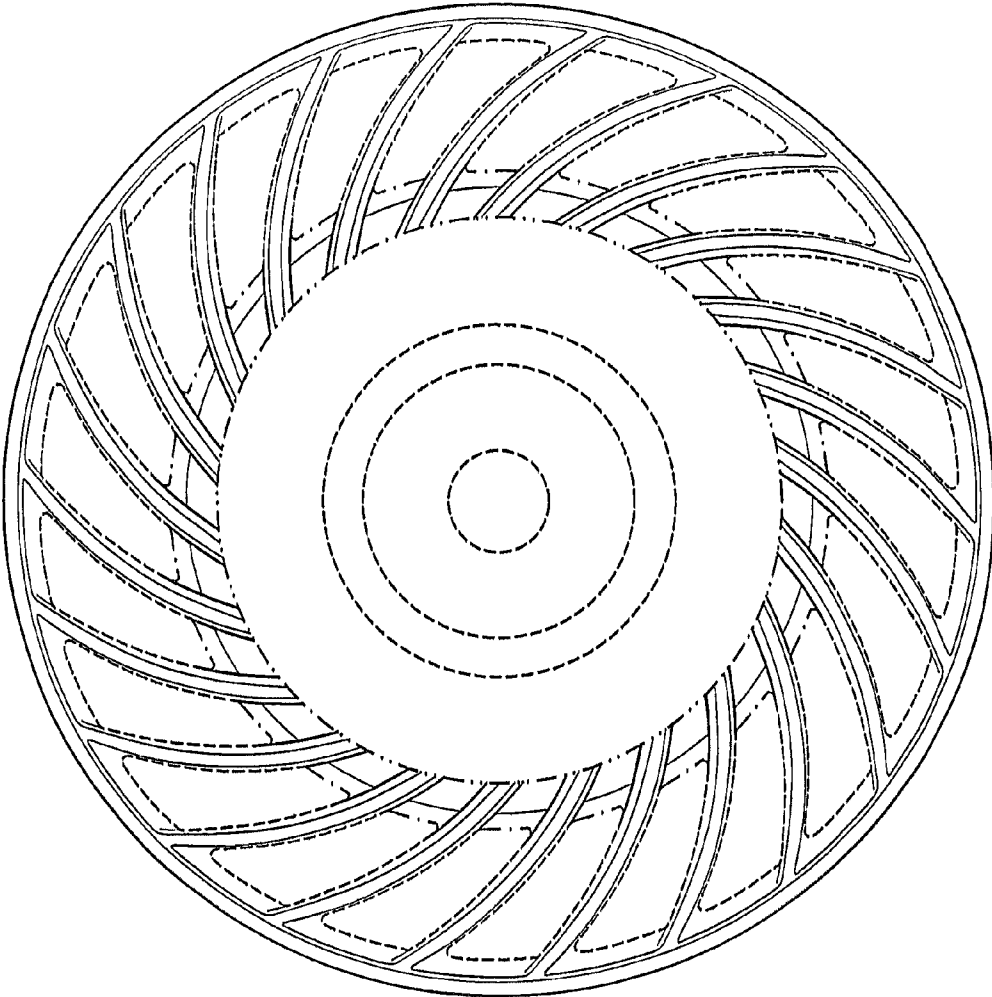

FIG. 3

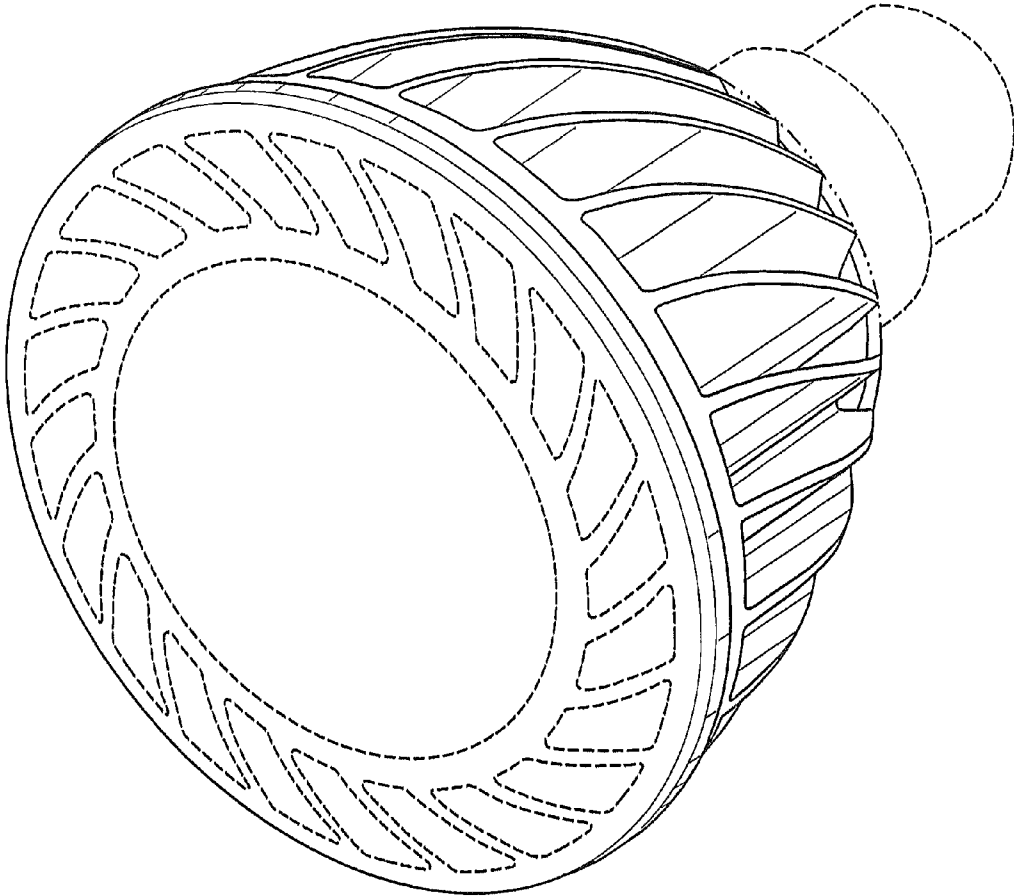

FIG. 4

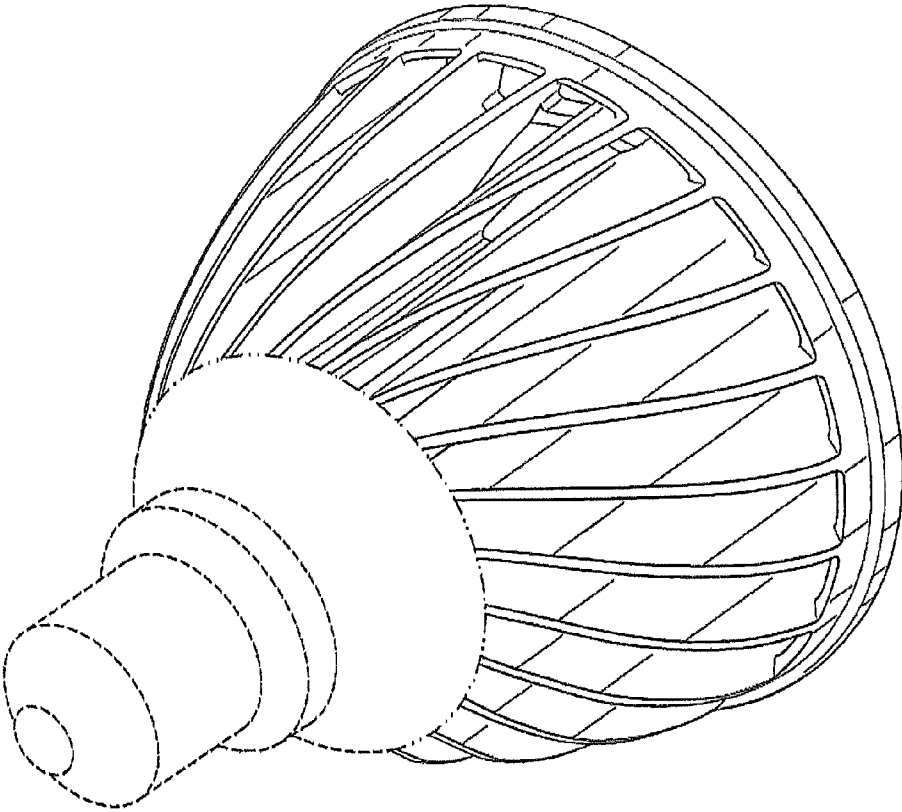

FIG. 5