

(19)



(11)

EP 1 553 219 B1

(12)

EUROPEAN PATENT SPECIFICATION

(45) Date of publication and mention of the grant of the patent:
23.04.2008 Bulletin 2008/17

(51) Int Cl.:
D01G 19/18 (2006.01)

(21) Application number: **05000382.1**

(22) Date of filing: **11.01.2005**

(54) **Combing machine for cotton and the like with improved sliver forming device**

Kämmmaschine für Baumwolle und dergleichen mit verbesserter Vorrichtung zur Faserbandformung

Machine de peignage de coton ou similaire avec dispositif de formation de ruban amélioré

(84) Designated Contracting States:
CH DE FR IT LI

(30) Priority: **12.01.2004 IT MI20040021**

(43) Date of publication of application:
13.07.2005 Bulletin 2005/28

(73) Proprietor: **Ceriani, Aldo**
20034 Giussano (Prov. of Milano) (IT)

(72) Inventor: **Ceriani, Aldo**
20034 Giussano (Prov. of Milano) (IT)

(74) Representative: **Modiano, Micaela Nadia et al**
Dr. Modiano & Associati SpA
Via Meravigli 16
20123 Milano (IT)

(56) References cited:
DE-A1- 2 139 305 **GB-A- 990 763**
US-A- 5 022 122 **US-A1- 2001 014 995**
US-B1- 6 170 126

EP 1 553 219 B1

Note: Within nine months from the publication of the mention of the grant of the European patent, any person may give notice to the European Patent Office of opposition to the European patent granted. Notice of opposition shall be filed in a written reasoned statement. It shall not be deemed to have been filed until the opposition fee has been paid. (Art. 99(1) European Patent Convention).

Description

[0001] The present invention relates to a combing machine for cotton, wool and the like with improved sliver forming device.

[0002] More particularly, the invention relates to a combing machine provided with a device for forming sliver of combed material, that has a higher combed material production rate than known types of solutions.

[0003] Currently conventional combing machines have, downstream of the combing section, a sliver forming section, in which the combed cotton is formed as a sliver by means of mechanisms with differentials or by means of various lever mechanisms.

[0004] Conventional combing machines accordingly have, downstream of the combing section, various lever mechanisms and/or differentials that are adapted to overlap the material depending on the length of the fibers. However, these devices have a considerable mechanical complexity and moreover are unable to overlap the material as precisely as needed; moreover, it is not possible to vary the overlap while the combing machine is operating.

[0005] Another drawback of conventional combing machines, as regards the sliver forming section, is the fact that they are unable to perform accurate removal of dust from the material, accordingly forming a sliver of insufficient quality.

[0006] US-A-5 022 122 discloses a combing machine with at least one detaching roller.

[0007] The aim of the present invention is to provide a combing machine for cotton and the like with an improved sliver forming device that allows to perform an accurate and optimum overlap of the cotton tufts.

[0008] Within this aim, an object of the present invention is to provide a combing machine for cotton and the like with a sliver forming device that allows to vary the overlap of the cotton tufts while the combing machine is operating, though having a reduced mechanical complexity.

[0009] Another object of the present invention is to provide a combing machine for cotton and the like that allows to achieve further removal of dust from the material, in addition to the dust removal performed during the combing of the head tufts.

[0010] Another object of the present invention is to provide a combing machine for cotton and the like with an improved sliver forming device that is highly reliable, relatively simple to provide, and at competitive costs.

[0011] This aim and these and other objects that will become better apparent hereinafter are achieved by a combing machine for cotton, wool and the like with an improved sliver forming device, as defined in claim 1.

[0012] Further characteristics and advantages of the invention will become better apparent from the description of some embodiments of the combing machine according to the present invention, illustrated by way of non-limiting example in the accompanying drawings, wherein:

Figure 1 is a schematic side elevation view of the combing machine according to the present invention; and

5 Figure 2 is a schematic view of a second embodiment of the combing machine according to the present invention.

[0013] With reference to the figures, the combing machine according to the present invention, generally designated by the reference numeral 1, comprises a combing section, which is disclosed in a copending patent application by the same Applicant, which is not described here in detail, followed by a sliver forming section 2, to which the present invention relates.

[0014] In order to understand the structure and operation of the sliver forming section 2, it is necessary to explain the operation of the combing section upstream of the sliver forming section.

20 **[0015]** The combing section, designated by the reference numeral 3, comprises a roller 4 for feeding tufts 5 of cotton to be combed, which are passed between two jaws 6 and 7, which are provided with at least one comb that is adapted to comb the cotton tufts 5. The combed tufts, in which therefore all the fibers have the same length, since fibers that are shorter than the preset length have been rejected earlier, are sent to a fixed comb 8, which combs the tails of the cotton tufts 5 and provides the combed cotton to the sliver forming section 2, which comprises at least one pair of rollers 9 and 10 through

25 30 which the combed material 5 is passed continuously. **[0016]** The combed material 5 in output from the rollers 9 and 10 is conveniently sent to a device 11 for forming the combed sliver, comprising a box-like body 12, which comprises at least one opening 13 on each side for the emission of air at negative pressure and, at the upper region of the box-like body 12, at least one, and preferably a plurality of, suction holes or notches 14, adapted to act by negative pressure, above which a mat or belt 15, conveniently made of permeable material, is arranged; said mat conveys the material that arrives from the rollers 9 and 10. Conveniently, the mat 15 is operated by actuation means 19.

35 40 **[0017]** The box-like body 12 can be easily removed/positioned, since it is pivoted in a point 17 and kept under traction by means of a spring 18, so that it is in contact with the actuation means 19.

[0018] In order to retain the material 5 in contact with the mat or belt 15 that passes above the box-like body 12, suction is used; said suction is generated by means of the holes 14, which allow to keep the belt, and therefore the combed material 5 arranged thereon, in contact with the box-like body 12 of the sliver forming device.

45 50 **[0019]** Conveniently, the rollers 16 are actually two output rollers 16, which unload the combed material 5 formed into a sliver onto a collection surface, not shown.

[0020] Conveniently, the material 5 deposited on the belt or mat 15, which is preferably of the permeable type,

is formed into a sliver by using the mat that provides the overlap of the tufts of combed material, utilizing the ratio between the length of the material 5 that arrives from the rollers 9 and 10 and the advancement speed of the mat 15.

[0021] In order to keep the fibers on the mat 15 in an orderly and parallel fashion, providing an optimum overlap of the cotton tufts, the holes 14 are used to provide a negative pressure and thus keep the material 5 in contact with the mat 15.

[0022] The number, position and cross-section of the holes 14 are extremely important factors for the optimum overlap of the tufts 5 and accordingly for the quality of the sliver of resulting combed material.

[0023] Moreover, the rate of advancement of the material 5 determines its degree of overlap.

[0024] The advantages that can be achieved by the sliver forming section according to the present invention are the fact that the various lever systems and/or differential devices typical of the background art are eliminated completely. Moreover, the overlap of the material is considerably more precise, and it is possible to vary the overlap while the combing machine is operating, varying for example the conveyance rate of the combed material 5.

[0025] In practice it has been observed that the combing machine according to the present invention fully achieves the intended aim and objects, since it allows to obtain a sliver of combed material in an extremely simple manner and with a high yield.

[0026] The combing machine thus conceived is susceptible of numerous modifications and variations, all of which are within the scope of the appended claims.

Thus, for example, it is possible to provide more than one pair of rollers that pick up the material 5 in output from the fixed comb 8, according to what is shown for example in Figure 2, which illustrates the presence of two separate pairs of rollers 9 and 10 arranged in succession.

[0027] All the details may further be replaced with other technically equivalent elements.

[0028] In practice, the materials used, as well as the contingent shapes and dimensions, may be any according to requirements and to the state of the art.

[0029] Where technical features mentioned in any claim are followed by reference signs, those reference signs have been included for the sole purpose of increasing the intelligibility of the claims and accordingly such reference signs do not have any limiting effect on the interpretation of each element identified by way of example by such reference signs.

Claims

1. A combing machine (1) for cotton, wool and the like with an improved sliver forming device, **characterized in that** it comprises at least one pair of rollers (9,10) that are adapted to pick up continuously combed material from a combing section (3) of the

combing machine (1) and to send said material to a sliver forming device (2), which comprises a belt (15) that can move continuously around a box-like body (12), said combed material being transportable on said belt, at least one pair of output rollers (16) being provided for the continuous actuation of said belt (15) and for the transport in output of said combed material formed into a sliver, said box-like body (12) comprising at least one opening (13) on each side for the emission of air at negative pressure and at least one hole (14) arranged at the top of the box-like body (12) and below said belt (15), in order to create a negative pressure.

2. The combing machine according to claim 1, **characterized in that** said belt (15) is made of permeable material.
3. The combing machine according to one or more of the preceding claims, **characterized in that** it comprises a plurality of holes (14) arranged on the top of said box-like body (12), below said continuously moving belt (15).
4. The combing machine according to one or more of the preceding claims, **characterized in that** it comprises an additional pair of rollers (9, 10), which are adapted to convey said combed material in output from the combing section (3) of said combing machine (1) to said continuously moving belt (15).

Patentansprüche

1. Eine Kämmmaschine (1) für Baumwolle, Wolle und dergleichen mit einer verbesserten Vorrichtung zur Faserbandformung, **dadurch gekennzeichnet, dass** sie mindestens ein Paar Rollen (9, 10) umfasst, die ausgebildet sind, um kontinuierlich gekämmtes Material aus einem Kämmschnitt (3) der Kämmmaschine (1) aufzunehmen und um das Material an eine Vorrichtung (2) zur Faserbandformung zu schicken, die ein Band (15) umfasst, das sich kontinuierlich um einen kastenähnlichen Körper (12) herum bewegen kann, wobei das gekämmte Material auf dem Band transportierbar ist und mindestens ein Paar von Ausgangsrollen (16) für den kontinuierlichen Antrieb des Bandes (15) und für den Transport in die Ausgabe des gekämmten Materials bereitgestellt wird, das in ein Faserband geformt wurde, wobei der kastenähnliche Körper (12) mindestens eine Öffnung (13) an jeder Seite für die Emission von Luft bei Unterdruck und mindestens ein Loch (14) umfasst, das oben auf dem kastenähnlichen Körper (12) und unterhalb des Bandes (15) angebracht ist, um einen Unterdruck zu erzeugen.
2. Die Kämmmaschine gemäß Anspruch 1, **dadurch**

gekennzeichnet, dass das Band (15) aus durchlässigem Material besteht.

gnage (3) de ladite machine de peignage (1) vers ladite courroie continuellement mobile (15).

3. Die Kämmaschine gemäß einem oder mehreren der obigen Ansprüche, **dadurch gekennzeichnet, dass** sie eine Vielzahl von Löchern (14) umfasst, die oben auf dem kastenähnlichen Körper (12), unter dem sich kontinuierlich bewegenden Band (15), angebracht sind. 5
10
4. Die Kämmaschine gemäß einem oder mehreren der obigen Ansprüche, **dadurch gekennzeichnet, dass** sie ein zusätzliches Paar von Rollen (9, 10) umfasst, die ausgebildet sind, um das gekämmte Material in die Ausgabe vom Kämmabschnitt (3) der Kämmaschine (1) auf das sich kontinuierlich bewegende Band (15) zu befördern. 15
20

Revendications 20

1. Machine de peignage (1) pour coton, laine et analogues avec dispositif de formation de ruban amélioré, **caractérisée en ce qu'**elle comprend au moins une paire de rouleaux (9, 10) qui sont adaptés pour prendre en continue du matériau peigné depuis une section de peignage (3) de la machine de peignage (1) et pour envoyer ledit matériau à un dispositif de formation de ruban (2), qui comprend une courroie (15) qui peut se déplacer continuellement autour d'un corps en forme de boîte (12), ledit matériau peigné étant transportable sur ladite courroie, au moins une paire de rouleaux de sortie (16) étant prévus pour l'actionnement continu de ladite courroie (15) et pour le transport en sortie dudit matériau peigné formé en un ruban, ledit corps en forme de boîte (12) comprenant au moins une ouverture (13) sur chaque coté pour l'émission d'air à pression négative et au moins un trou (14) positionné au sommet dudit corps en forme de boîte (12) et sous ladite courroie (15) afin de créer une pression négative. 25
30
35
40
2. Machine de peignage selon la revendication 1, **caractérisée en ce que** ladite courroie (15) est faite d'un matériau perméable. 45
3. Machine de peignage selon une ou plusieurs des revendications précédentes, **caractérisée en ce qu'**elle comprend une pluralité de trous (14) agencés sur le sommet dudit corps en forme de boîte (12), sous ladite courroie continuellement mobile (15), 50
4. Machine de peignage selon une ou plusieurs des revendications précédentes, **caractérisée en ce qu'**elle comprend une paire de rouleaux supplémentaire (9, 10) qui sont adaptés pour convoyer ledit matériau peigné en sortie depuis la section de pei- 55

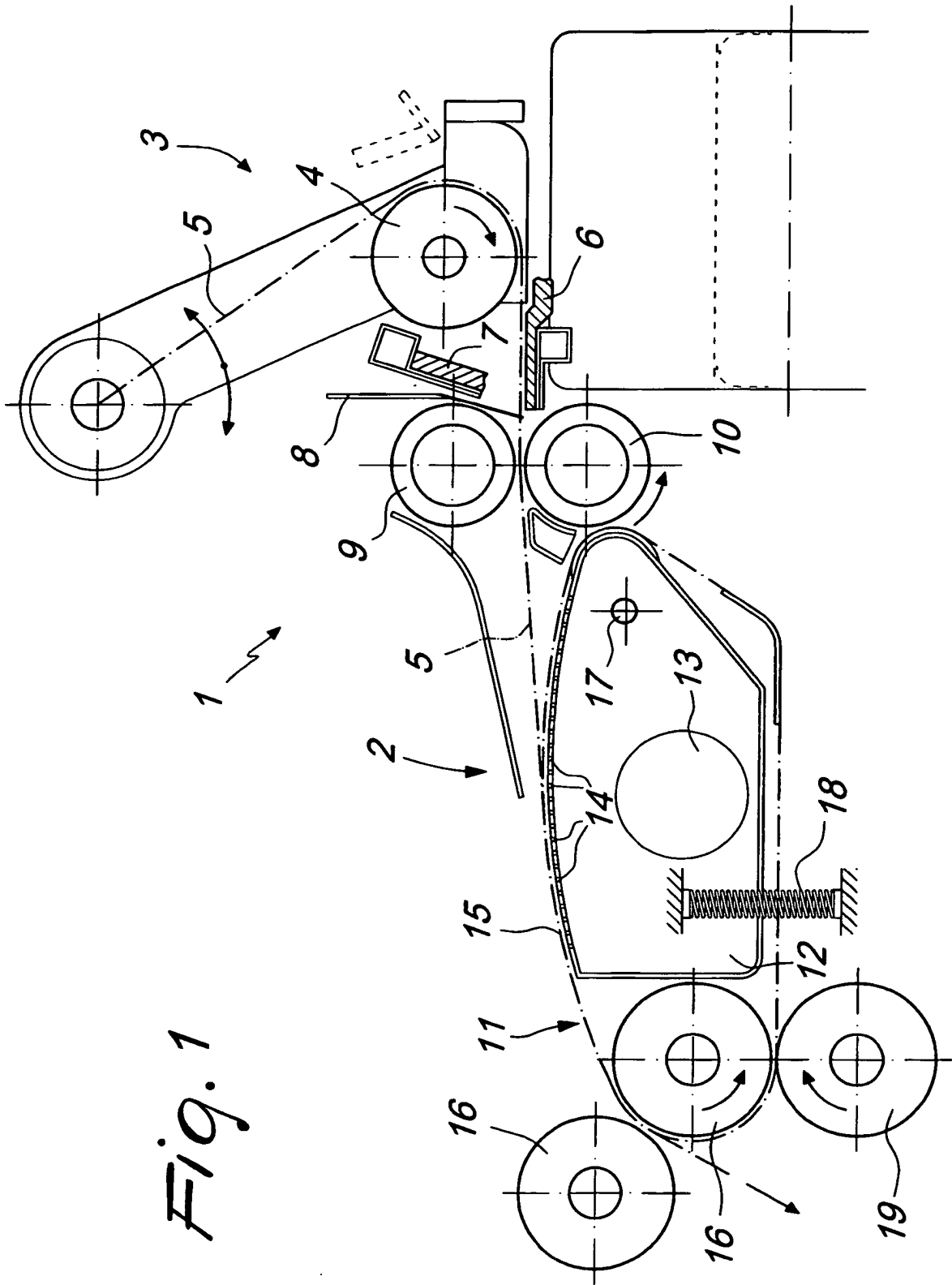

Fig. 1

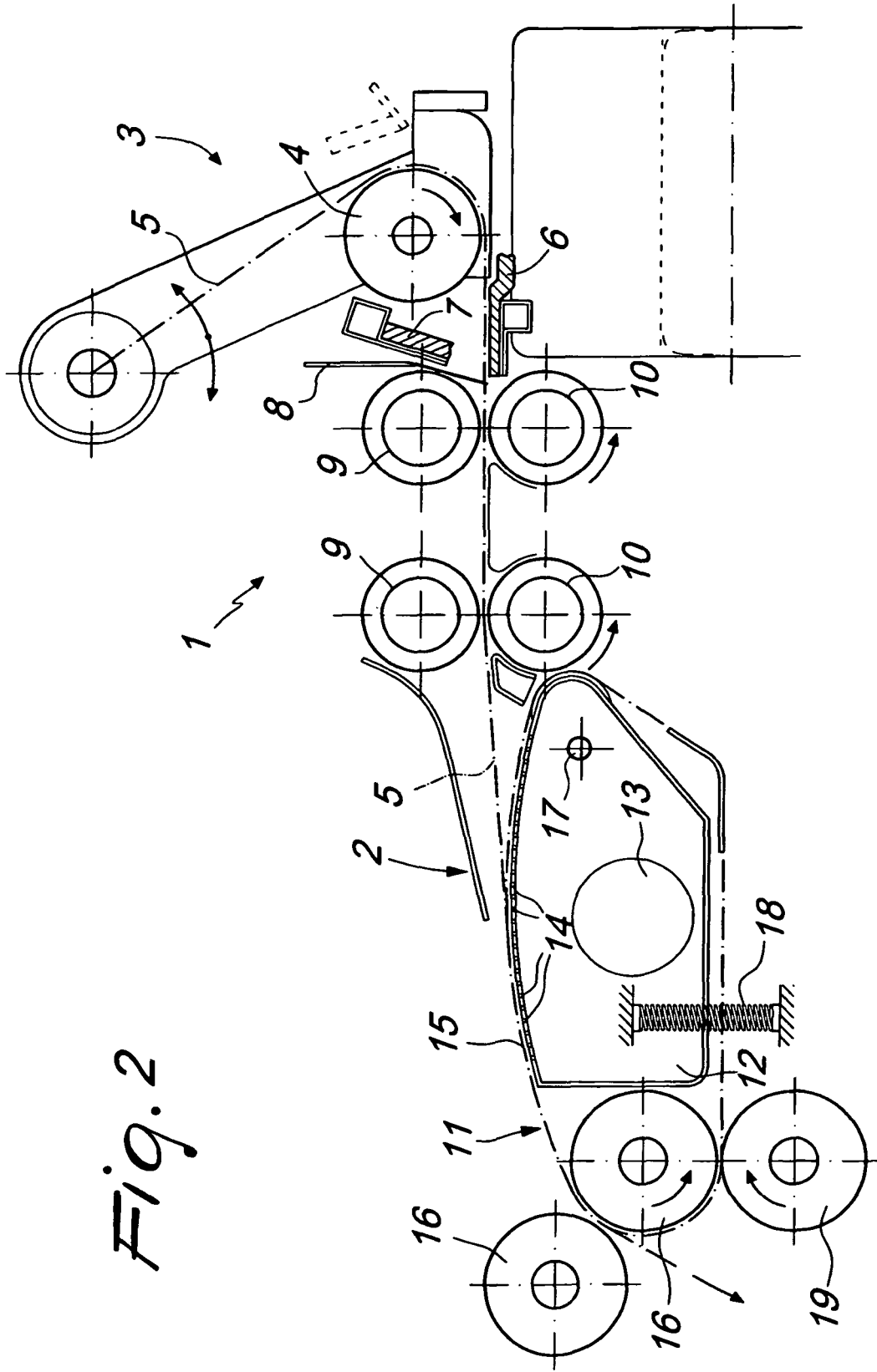

Fig. 2

REFERENCES CITED IN THE DESCRIPTION

This list of references cited by the applicant is for the reader's convenience only. It does not form part of the European patent document. Even though great care has been taken in compiling the references, errors or omissions cannot be excluded and the EPO disclaims all liability in this regard.

Patent documents cited in the description

- US 5022122 A [0006]