

W. P. COLLINS.
 SPRING HINGE.
 APPLICATION FILED MAR. 16, 1909.

936,090.

Patented Oct. 5, 1909.

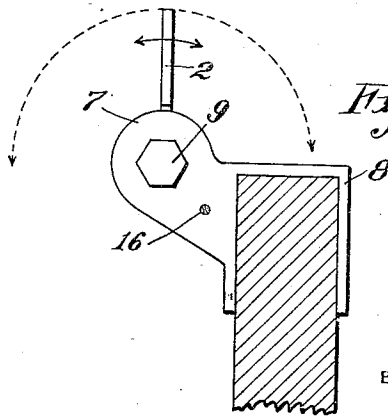
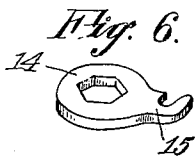
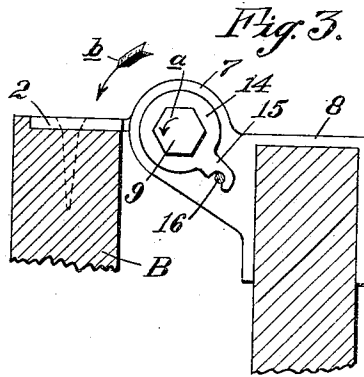
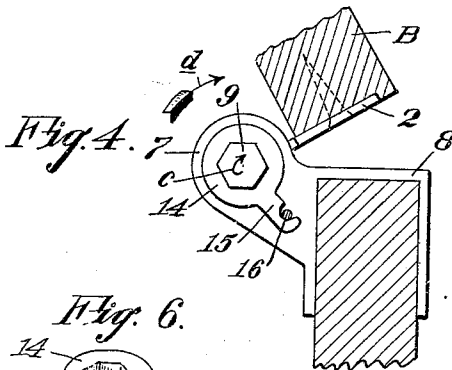
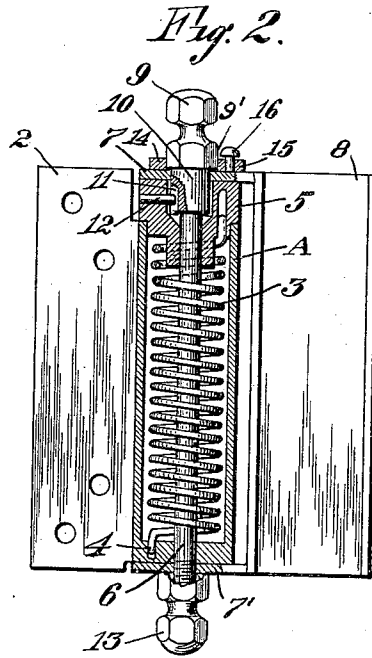
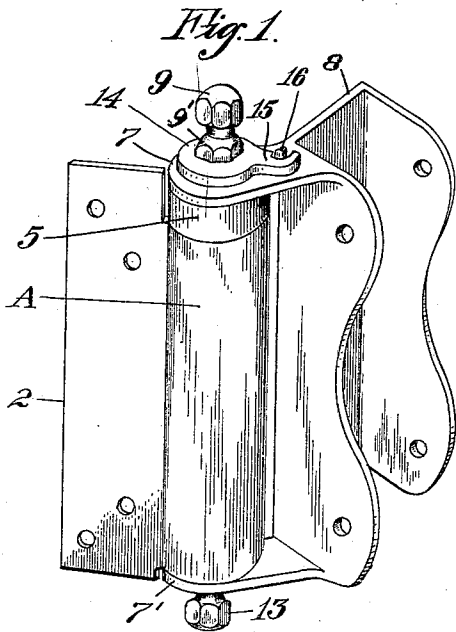

WITNESSES

R. S. Berry
Hastberg

INVENTOR
 WILLIAM P. COLLINS
 BY *Geo H Strong*
 HIS ATTORNEY

UNITED STATES PATENT OFFICE.

WILLIAM P. COLLINS, OF SAN FRANCISCO, CALIFORNIA.

SPRING-HINGE.

936,090.

Specification of Letters Patent.

Patented Oct. 5, 1909.

Application filed March 16, 1909. Serial No. 483,686.

To all whom it may concern:

Be it known that I, WILLIAM P. COLLINS, a citizen of the United States, residing at the city and county of San Francisco and State of California, have invented new and useful Improvements in Spring-Hinges, of which the following is a specification.

My invention relates to spring hinges and particularly to that class wherein the tension or elastic force of the spring is adjustable.

The object of my invention is to provide a spring hinge simple in construction, compact in form and economical in cost of manufacture.

A further object is to provide a spring hinge adapted to be used either to keep the door normally open, or normally closed, wherein the direction of the spring action may be reversed without disconnecting the hinge.

The invention consists of the parts and the construction and combination of parts as hereinafter more fully described and claimed, having reference to the accompanying drawings in which:

Figure 1 is a perspective view of the invention. Fig. 2 is a vertical section. Fig. 3 is a plan view. Fig. 4 is a plan view showing the collar in a reversed position. Fig. 5 is a plan view with the collar omitted. Fig. 6 is a detail in perspective of the collar.

In the drawings I have shown a hinge of the type commonly used in swinging doors from marble jambs, or casings. A is a cylinder or barrel, formed integral with the movable leaf 2 of the hinge; this leaf 2 being the portion usually attached to the door. Within the barrel A is a coil spring 3 having its lower end anchored in the bottom of the barrel as at 4 Fig. 2. The upper end of the spring 3 is adapted to be engaged with a plug 5, in the open end of the barrel A. The barrel and plug are coincidentally perforated in the line of the axis of the barrel to pass a pivot pin 6; and the barrel and plug are mounted between flanges 7—7' on the bearing wing 8 which is fixed to the door casing; the pin or bolt 6 also passing through holes in the flanges 7—7' and holding the two wings together and forming the pivot for the door B. The upper end of the pin 8 is provided with a double nut-shaped head 9—9', and an enlarged shoulder 10 which extends into a chamber in the plug 5. A slot 11 in the shoulder 10 engages an inwardly extending radial pin or projection

12 on the plug 5. A nut 13 screws on the lower projecting end of the bolt pin 8 to hold the parts of the hinge together. In order to place tension on the spring, I employ a plate 14 having a polygonal opening of a size to pass the polygonal sided head 9 and seat on the head 9'; this plate having a projecting portion or hook 15 adapted to bear against a pin or stop 16 on the flange 6. The locking plate 14 forms a means to prevent the plug 5 turning so as to produce the desired action of spring 3. The locking plate 14 is removable and reversible and may be adjusted on the head 9 as desired, according as to whether it is desired to have the door ordinarily stand open or closed, or according to the desired degree of tension on the spring 3. Or, omitting the plate 14, the swinging portion of the hinge will be free to be moved to its limit in either direction as shown in Fig. 5 without action from the spring. To adjust the spring 3, the head 9 of the bolt pin 8 is turned by means of a wrench or pair of pliers in one direction or the other, according as to whether the door is to stand normally, in closed position or open position and the locking plate is made to engage accordingly with one side or the other of the stop pin 15. Thus, by winding the spring 3 in the direction of the arrow *a*, Fig. 3, the tension of the spring acts on the wing 2 and door B in the direction of the arrow *d* and the plate 14 is placed in the position shown to retain the spring in tension. In like manner, the spring may be wound in the direction of the arrow *c*, Fig. 4, and the tension of the spring will then act in the direction of the arrow *d*, tending to retain the wing 2 in an open position; the plate 14 being placed with the hook 15 engaging the inner side of the stop pin 16.

It is obvious that by means of the adjustments described, a door swinging on hinges of this kind, may be made to swing either to an open or closed position, as desired, without removing from the hinges; that any degree of tension required may be obtained; and if desired the locking plate 14 is easily removed so as leave the door to swing full without being controlled by the spring.

Having thus described my invention, what I claim and desire to secure by Letters Patent is—

In a hinge, the combination with a movable leaf member having a barrel portion

60

65

70

75

80

85

90

95

100

105

110

provided with an open end, a spring in said barrel having one end attached thereto, a plug loosely seated in the open end of the barrel and to which the opposite end of the
5 spring is attached, said plug and the closed end of the barrel having coincident perforations, of a fixed hinge member having perforated flanges, a pivot bolt passed through
10 said perforations and the perforations of said flanges, means, including a radially projecting pin on the plug and a groove in the pivot bolt for locking said bolt and pin together, a reversible locking plate engageable

with the pivot bolt, and a fixed stop to maintain the spring on tension, the end of the
15 bolt having a many-sided projection and the locking plate having a many-sided opening to engage said projection.

In testimony whereof I have hereunto set my hand in presence of two subscribing wit-
20 nesses.

WILLIAM P. COLLINS.

Witnesses:

CHARLES A. BONFIELD,
CHARLES EDELMAN.