



(11) **EP 1 530 266 B1**

(12) **EUROPEAN PATENT SPECIFICATION**

(45) Date of publication and mention of the grant of the patent:
31.12.2008 Bulletin 2009/01

(51) Int Cl.:
H01R 13/58 (2006.01)

(21) Application number: **04256876.6**

(22) Date of filing: **05.11.2004**

(54) **Socket connector**

Steckeraufnahmeverbinder

Connecteur à prise femelle

(84) Designated Contracting States:
GB

(30) Priority: **07.11.2003 JP 2003379198**

(43) Date of publication of application:
11.05.2005 Bulletin 2005/19

(73) Proprietor: **J.S.T. Mfg. Co., Ltd.**
Osaka-shi,
Osaka (JP)

(72) Inventors:
• **Moriwake, Ryo,**
Osaka Engineering Ctr.
Nishiyodogawa-ku
Osaka-shi
Osaka (JP)

- **Horiuchi, Hideaki,**
Osaka Engineering Ctr.
Nishiyodogawa-ku
Osaka-shi
Osaka (JP)
- **Takatsuki, Shohei,**
Osaka Engineering Ctr.
Nishiyodogawa-ku
Osaka-shi
Osaka (JP)

(74) Representative: **DeVile, Jonathan Mark**
D Young & Co
120 Holborn
London EC1N 2DY (GB)

(56) References cited:
EP-A1- 1 313 176 **EP-A2- 0 844 688**

EP 1 530 266 B1

Note: Within nine months of the publication of the mention of the grant of the European patent in the European Patent Bulletin, any person may give notice to the European Patent Office of opposition to that patent, in accordance with the Implementing Regulations. Notice of opposition shall not be deemed to have been filed until the opposition fee has been paid. (Art. 99(1) European Patent Convention).

Description

[0001] The present invention relates to socket connectors for connection to a header connector mounted on a surface of an object for mounting such as printed circuit board.

[0002] Japanese Patent Publication 3262732 discloses an insulation displacement connector that comprises contacts to which wires are connected by insulation displacement connection and an insulative housing wherein contact receiving chambers that isolate and receive contacts individually are separated from each other individually by partition walls, the top part and the rear end part of the contact receiving chamber are open for inserting the wire into it, and strain reliefs or fitting-on parts for the wire are provided on the partition wall parts on both sides of the rear end of the opening.

[0003] When a header connector is mounted on a surface of a printed circuit board and a socket connector to which terminal ends of wires are insulation-displacement-connected is to be connected to the header connector, it is a common practice to provide the socket connector with such strain reliefs as those disclosed in Japanese Patent Publication 3262732 so as to enhance the strength against pulling-about of the wires causing bending or deformation thereof.

[0004] In this case, as the strain reliefs rise in the height direction from the tops of the partition walls of the socket housing, the height of the socket connector from the printed circuit board will get higher, preventing reduction in the height of the connection structure between the header connector and the socket connector. Moreover, it is highly desired to increase as much as possible the strength against the pull-out or pulling of the wires in their leading-out direction.

[0005] Various aspects and features of the present invention are defined in the appended claims.

[0006] The present invention was made in view of the above points. Embodiments of the present invention can realize a reduction in the height of the connection structure between a header connector and a socket connector by enclosing the connecting part of each socket contact and a wire by means of the socket housing and an object for mounting such as a printed circuit board and providing each socket contact with an insulation barrel so as to increase the strength against wire pulling-about and in turn to eliminate the need of providing strain reliefs. Embodiments of the present invention can also provide other wire holding means so as to increase the strength against wire pulling-out as high as possible.

[0007] According to the present invention there is provided a socket connector comprising, when a depth direction, a width direction and a height direction all being perpendicular to each other are assumed, a socket housing that is provided with a wire insertion groove, which is concaved in a bottom face being one end face in the height direction toward a top face being the other end and extended up to an end face on the front side in the

depth direction, and a receiving concaved part, which is located on the rear side in the depth direction of the wire insertion groove, is interconnected with the wire insertion groove and opened to the bottom face and into which a header contact of a counterpart header connector being mounted on a surface of an object for mounting is to be inserted, and a socket contact that is inserted into the wire insertion groove and provided with a contacting part being located at the rear end in the depth direction and set in the receiving concaved part to contact the header contact, an insulation barrel being located at the front end in the depth direction, being a plate piece rising substantially in the height direction and being to grip an insulation of a wire, and a slot being located between the contacting part and the insulation barrel and being formed by concaving at one end in the height direction of a plate piece rising substantially in the height direction to break the insulation of the wire and make connection with the conductor thereof, the socket connector being so arranged that when the terminal end of the wire extending in the depth direction is pressed into the wire insertion groove in the height direction to achieve insulation displacement connection with the slot, the insulation of the wire is gripped by the insulation barrel and the socket connector is connected to the header connector being mounted on an object for mounting, the wire insertion groove of the socket housing will be blocked by the object for mounting.

[0008] When this socket connector is connected to the header connector that is provided on a surface of an object for mounting, the header contact will be inserted into the receiving concaved part of the socket connector, and the header contact will contact the socket contact. In that case, as the socket contact is inserted into the wire insertion groove, the strength of coupling between the socket contact and the socket housing is high. When wire is connected to the socket connector and this socket connector is connected to the header connector that is mounted on a surface of an object for mounting, the wire insertion groove of the socket housing will be blocked by the object for mounting, and the periphery of the slot being the connecting part of the socket contact and the wire will be enclosed by the socket housing and the object for mounting, hence the pulling-about force of the wire will be received by the socket housing or the object for mounting and will not reach the slot; thus the strength against the pulling-about of the wire is enhanced. Moreover, as the insulation barrel of the socket contact grips the insulation of the wire, the pulling-about force of the wire will be received by the insulation barrel and will not reach the slot; thus the strength against pulling-about of the wire is enhanced. As a result, there is no need of providing strain reliefs, and reduction in the height of the connection structure of the header connector and the socket connector is realized. Furthermore, as the insulation barrel of the socket contact grips the insulation of the wire, the pulling-out force of the wire will be received by the insulation barrel and will not reach the slot, hence the strength

against pulling-out of the wire is enhanced. Moreover, as the coupling force between the socket contact and the wire is enhanced by the insulation barrel, even when subjected to the pulling-about force or the pulling-out force of the wire, no relative movements will be generated between the socket contact and the wire; thus the reliability of the connection between the slot and the conductor of the wire is enhanced.

[0009] In the socket connector according to the present invention, the strength against pulling-about of the wire is enhanced by enclosing the connecting part between the socket contact and the wire by means of the socket housing and an object for mounting and also by providing the socket contact with an insulation barrel, hence there is no need of providing strain reliefs, and in turn, reduction in the height of the connection structure between the header connector and the socket connector can be realized. Moreover, the strength against pulling-out of the wire can be enhanced by the insulation barrel. Furthermore, as relative movements between the socket contact and the wire are not generated, the reliability of the connection between the slot and the conductor of the wire can be enhanced.

[0010] In the socket connector of the present invention, the socket housing may be provided, at the opening of the wire insertion groove on the bottom face side, with protruding parts that protrude inward in the width direction to grip together with the bottom face of the wire insertion groove, with a contact pressure, the socket contact that is inserted into from the front in the depth direction.

[0011] With this arrangement, as the socket contact is restrained from moving in the height direction by the bottom face and the protruding parts, the strength against pulling-about of the wire in this direction is enhanced.

[0012] In the socket connector of the present invention, the socket contact may be provided with fitting-on pieces that rise substantially in the height direction from both ends in the width direction, and faces constituting the wire insertion groove of the socket housing may be provided with catching parts that catch the fitting-on pieces so as to prevent the socket contact from shifting frontward in the depth direction.

[0013] With this arrangement, as the catching parts catch the fitting-on pieces and the socket contact is prevented from shifting frontward in the depth direction, the strength against pulling-out of the wire is enhanced. Hence it is possible not to adopt the so-called lance structure wherein either the socket housing or the socket contact is provided with a fitting-on piece and the other is provided with a fitting-on hole in which the fitting-on piece is hooked. As a result, it becomes possible to eliminate from the socket housing any fitting-on piece or hole that is formed to make a fitting-on hole, and to make the top face of the socket housing free of any hole, and it becomes possible to reduce the thickness of the socket housing.

[0014] Accordingly, as the catching parts receive the

fitting-on parts to prevent the socket contact from shifting frontward in the depth direction, the strength against pulling-out of the wire can be enhanced. Moreover, as the top face of the socket housing can be made free of any hole, reduction in the thickness of the socket housing can be made.

[0015] The socket connector of the present invention may be so arranged that the header connector comprises a header housing that is provided with a receiving chamber that penetrates the header housing from a top face being one end face in the height direction to a bottom face being the other end face and extends up to an end face at the front in the depth direction, and a header contact of a blade type that is provided in the header housing so that a contacting part being formed into a plate facing in the width direction protrudes from the rear in the depth direction into the receiving chamber, a protruding part that fits into the receiving chamber is formed at the rear end in the depth direction of the socket housing, the protruding part is provided with a receiving concaved part in such a way that the receiving concaved part opens to the bottom face and an end face at the rear in the depth direction, and the contacting part of the socket contact is so arranged that the contacting part contacts an end face in the thickness direction of the header contact.

[0016] With this arrangement, when the socket connector to which the wire is insulation-displacement-connected is connected to the header connector, the protruding part of the socket housing will fit into the receiving chamber of the header housing, the bottom face of the socket housing will contact the object for mounting that is exposed to the receiving chamber of the header housing, and the wire insertion groove will be blocked by the object for mounting.

[0017] Accordingly, one example of the socket connector that is to be connected to the header connector having the header contact of a blade type was fully described.

[0018] In the following, some embodiments of the present invention will be described with reference to the drawings.

Fig. 1 is a perspective view of the socket connector of an embodiment seen from the bottom face side.

Fig. 2 is plan view of the socket connector of the embodiment seen from the bottom face side.

Fig. 3 is a sectional view along the line III-III of Fig. 2.

Fig. 4 is a sectional view along the line IV-IV of Fig. 2.

Fig. 5 is a sectional view along the line V-V of Fig. 2.

Fig. 6 is a sectional view along the line VI-VI of Fig. 2.

Fig. 7 is a sectional view along the line VII-VII of Fig. 2.

Fig. 8 is a sectional view of the socket housing of the embodiment. The position of the section line is similar to that of Fig. 3.

Fig. 9 is a perspective view of the socket contact of the embodiment.

Fig. 10 is a perspective view of the socket connector

of the embodiment with wires connected thereto. It is seen from the bottom face side.

Fig. 11 is a perspective view of the socket connector of the embodiment with wires connected thereto. It is seen from the top face side.

Fig. 12 is a perspective view of the header connector of the embodiment seen from the top face side.

Fig. 13 is a perspective view of the socket connector of the embodiment, which is connected to wires and then connected to the header connector of the embodiment.

Fig. 14 is a sectional view of the socket connector of the embodiment, which is connected to wires and then connected to the header connector of the embodiment. They are sectioned in a plane facing in the width direction and seen in the width direction.

Fig. 15 is a sectional view of the socket connector of the embodiment, which is connected to wires and then connected to the header connector of the embodiment. They are sectioned in a plane facing in the depth direction and seen from the front in the depth direction.

[0019] Some embodiments of the present invention will be described below. Fig. 1 through Fig. 7 show a socket connector 100 being an embodiment according to the present invention. A depth direction, a width direction and a height direction all being perpendicular to each other are assumed, and these directions are used for description. In the case of this embodiment, with reference to Fig. 2, the left-right direction of the diagram is the depth direction, the left of the diagram is the rear in the depth direction, and the right is the front in the depth direction. A direction perpendicular to the paper plane of the diagram is the height direction, and the top-bottom direction of the diagram is the width direction. The socket connector 100 comprises a socket housing 110 that is made of an insulative material, and socket contacts 120 that are made of a conductive material and provided in the socket housing 110. A counterpart header connector 200 comprises a header housing 210 that is made of an insulative material and header contacts 220 that are made of a conductive material and provided in the header housing 210. The socket connector 100 and the header connector 200 are of a two-pole type, and are provided with two contacts 120, two contacts 220, respectively, the contacts being arranged side by side; however, the number of poles of the socket connector and the header connector according to the present invention is not limited by it. The header connector 200 is mounted on a surface of an object for mounting P. The object for mounting P is an object that has a plane surface facing in the height direction and also has conductors being to be connected with the header contacts 220. This object for mounting P includes, for example, printed circuit board, flat flexible cable such as FFC (flexible flat cable) and FPC (flexible printed circuit), and casing of electronic equipment. Here the printed circuit board means a board wherein a con-

ductor pattern that is needed for connecting components is formed by printing according to the circuit design on the surface of an insulative board or on the surface and inside thereof. In the case of a casing of electronic equipment, an example is an insulator wherein conductors are formed on its surface by MID (molded interconnection device) technology that forms conductive plated layers. In the case of the present embodiment, the object for mounting P is a printed circuit board, and the header connector 200 is mounted on the surface of the printed circuit board being the object for mounting P.

[0020] As shown in Fig. 8, the socket housing 110 is provided with wire insertion grooves 115 that are concaved in the bottom face 111 being one end face in the height direction toward the top face 112 being the other end face and extended up to an end face 113 on the front side in the depth direction. Receiving concaved parts 116, which is interconnected with the wire insertion grooves 115 and opened to the bottom face 111 and into which the header contacts 220 of the header connector 200 are to be inserted, are provided on the rear side in the depth direction of the wire insertion grooves 115 of the socket housing 110.

[0021] The socket contacts 120 are inserted into the above-mentioned wire insertion grooves 115. This inserting is effected by, for example, so setting the dimensions that the socket contact 120 fits tight in the wire insertion groove 115. The socket contact 120 is formed by bending a plate material of a certain configuration into a box, and its main constituent members are a bottom wall facing in the height direction and side walls facing in the width direction and rising from both ends in the width direction of the bottom wall. However, the socket contact according to the present invention is not limited to such a configuration. At the rear end in the depth direction of the socket contact 120, a contacting part 121 that is set in the receiving concaved part 116 and is to contact the header contact 220 is provided. In the case of this embodiment, the contacting part 121 is formed by a plate piece that extends rearward in the depth direction from the bottom wall and substantially faces in the height direction, and the top end of the plate is bifurcated in the width direction and formed into a so-called a fork shape, and when seen in the height direction, it is shaped approximately into a U-shape as a whole. However, the contacting part of the socket contact of the present invention is not limited to such a configuration. At the front end in the depth direction of the socket contact 120, an insulation barrel 122 for gripping the insulation of the wire W is provided. This insulation barrel 122 is formed, in the socket contact 120, by a plate piece that rises substantially in the height direction. The direction of the plate piece is not limited, but here it faces substantially in the width direction. The insulation is gripped by bending this plate piece inward in the width direction and pressing the insulation of the wire W. The number of this plate piece may be one, two or more. In the case of this embodiment, the insulation barrel 122 comprises two plate pieces that

rise from both ends in the width direction of the bottom wall substantially in the height direction and face substantially in the width direction. In the socket contact 120, there is a plate that rises substantially in the height direction between the contacting part 121 and the insulation barrel 122. The direction that this plate piece faces in is not limited, but here it faces in the depth direction. The edge of the end in the height direction of this plate piece is concaved in an approximate U-shape, and the edges of this concaved part are made sharp, and a slot 123 is formed by the periphery of this edge, and it is arranged to break the insulation of a wire W to make a connection with the conductor that is present inside the insulation. In the case of this embodiment, the plate piece of the slot 123 rises from the bottom wall in the height direction. When a wire W is pressed into the slot 123 in the height direction, the slot 123 will break the insulation, and the conductor that is present inside the insulation will contact the slot 123 to make mechanical connection and electric connection between the slot 123 and the conductor of the wire W.

[0022] As shown in Fig. 10, this socket connector 100 is so arranged that when the terminal end of the wire W extending in the depth direction is pressed into the wire insertion groove 115 in the height direction to achieve insulation displacement connection with the slot 123, the insulation of the wire W is gripped by the insulation barrel 122 and the socket connector 100 is connected to the header connector 200 that is mounted on the object for mounting P, the wire insertion groove 115 of the socket housing 110 will be blocked by the object for mounting P.

[0023] As shown in Fig. 5, the opening of the wire insertion groove 115 on the bottom face side of the socket housing 110 is provided with protruding parts 117 that protrude inward in the width direction, and it is so arranged that the socket contact 120 that is inserted into from the front in the depth direction is gripped with a contact pressure between these protruding parts 117 and the bottom face 115a of the wire insertion groove 115. In this embodiment, it is so arranged that the side walls of the socket contact 120 are held tight with a contact pressure by the protruding parts 117 and the bottom face 115a of the wire insertion groove 115.

[0024] As shown in Fig. 6 and Fig. 9, the socket contact 120 is provided with fitting-on pieces 124 that rise substantially in the height direction from both sides in the width direction. The faces that constitute the wire insertion groove 115 of the socket housing 110 are provided with catching parts 118 that catch the fitting-on pieces 124 so as to prevent the socket contact 120 from shifting frontward in the depth direction. In the case of this embodiment, the fitting-on pieces 124 face substantially in the width direction and rise from both ends in the width direction of the bottom wall in the height direction. The catching part 118 is provided by concaving the side face 115b of the wire insertion groove 115 outward in the width direction. First the socket contact 120 is inserted into the wire insertion groove 115, then the fitting-on pieces 124

are bent a little outward in the width direction to fit the fitting-on pieces 124 into the catching parts 118. With this arrangement, if the socket contact 120 is made to move frontward in the depth direction, its fitting-on pieces 124 will hit on faces of the catching parts 118, the faces facing rearward and being located on the front side in the depth direction, and the socket contact 120 will be prevented from shifting. The fitting-on pieces 124 may be so provided that they are tilted a little outward in the width direction, and when the socket contact 120 is inserted into the wire insertion groove 115, the fitting-on pieces 124 will be deformed elastically so as to fit the fitting-on pieces 124 into the catching parts 118.

[0025] This socket connector 100 is connected to a header connector 200. As shown in Fig. 12, the header housing 210 is provided with a receiving chamber 214 that penetrates it from a top face 211 being one end face in the height direction to a bottom face 212 being the other end face and also extends up to an end face 213 at the front side in the depth direction. The header contact 220 is of a blade type and has a contacting part 221 that is formed into a plate facing in the width direction. The header contacts 220 are provided in the header housing 210 in such a way that their contacting parts 221 protrude from the rear in the depth direction into the receiving chamber 214. The header contact 220 is provided with a connecting part 222 in such a way that the connecting part 222 comes out of the bottom face 212 or its periphery of the header housing 210. The connecting part 222 is mounted by soldering, etc. onto an object for mounting P. The connecting part 222 may be soldered onto the surface of the object for mounting P or it may be inserted into a hole that is formed in the object for mounting P and then soldered. It does not matter whether this hole is through the object for mounting P or not. A protruding part 119, which fits into the receiving chamber 214, is formed at the rear end in the depth direction of the socket housing 110, and the protruding part 119 is provided with receiving concaved parts 116 in such a way that the receiving concaved parts 116 open to the bottom face 111 and the end face 114 at the rear in the depth direction, and they are so arranged that the contacting parts 121 of the socket contact 120 contact the contacting part 221 of the header contact 220 from both sides in the thickness direction in a nipping manner. The width of the receiving chamber 214 is narrowed at a location that is close to the end face 213 at the front in the depth direction of the header housing 210 to form a neck part. The header housing 210 is provided with fitting-on parts that protrude inward in the width direction to form this neck part, and these fitting-on parts prevent the socket connector 100 from coming off frontward in the depth direction. The protruding part 119 of the socket housing 110 and the constituent walls of the receiving chamber 214 of the header housing 210 are provided with locking mechanisms that enhance the strength of engagement when the protruding part 119 is fitted into the receiving chamber 214. To be more specific, the constituent walls of the receiving

chamber 214 are provided with concaved parts or locking parts 215, and the protruding part 119 is provided with projecting parts or locking parts 119a so that when the protruding part 119 is fitted into the receiving chamber 214, the locking parts will engage together through the use of their flexibility. Conversely, the protruding part 119 may be provided with concaved parts and the constituent walls of the receiving chamber 214 may be provided with projecting parts.

[0026] The functions and effects of the socket connector 100 of this embodiment will be described. When this socket connector 100 is connected to the header connector 200 that is provided on a surface of an object for mounting P, the header contacts 220 will be inserted into the receiving concaved parts 116 of the socket connector 100, and the header contacts 220 will contact the socket contacts 120. In that case, as the socket contact 120 is inserted into the wire insertion groove 115, the strength of coupling between the socket contact 120 and the socket housing 110 is high. When wires W are connected to the socket connector 100 and this socket connector 100 is connected to the header connector 200 that is mounted on a surface of an object for mounting P, the wire insertion grooves 115 of the socket housing 110 will be blocked by the object for mounting P, and the peripheries of the slots 123 being the connecting parts of socket contacts 120 and wires W are enclosed by the socket housing 110 and the object for mounting P. Accordingly, as shown in Fig. 14, the pulling-about forces F_b of the wires W will be received by the socket housing 110 or the object for mounting P and will not reach the slots 123; thus the strength against pulling-about of the wires W is enhanced. Moreover, as the insulation barrels 122 of the socket contacts 120 grip the insulations of the wires W, the pulling-about forces of the wires W will be received by the insulation barrels 122 and will not reach the slots 123; thus the strength against pulling-about of wires W is enhanced. As a result, there is no need of providing strain reliefs, and reduction in the height of the connection structure of the header connector 200 and the socket connector 100 is realized. Furthermore, as the insulation barrels 122 of the socket contacts 120 grip the insulations of wires W, as shown in Fig. 14, the pulling-out forces F_t of the wires W will be received by the insulating barrels 122 and will not reach the slots 123, and the strength against pulling-out of the wires W is enhanced. Moreover, as the binding forces between socket contacts 120 and the wires W are enhanced by the insulation barrels 1122, even when subjected to the pulling-about forces or the pulling-out forces of the wires W, no relative movements between the socket contacts 120 and the wires W will be generated; thus the reliability of the connection between the slots 123 and the conductors of the wires W is enhanced.

[0027] The present invention includes an embodiment of a socket connector wherein the wire insertion grooves are open on one side in the height direction and the socket contact is not restrained in the height direction near the

wire insertion grooves. However, in the above-mentioned embodiment, the socket housing 110 is provided, at the openings of the wire insertion grooves 115 on the bottom face side, with protruding parts 117 that protrude inward in the width direction to grip together with the bottom faces 115a of the wire insertion grooves 115, with contact pressure, the socket contacts 120 that are inserted into from the front in the depth direction. With this arrangement, as the socket contacts 120 are restrained from moving in the height direction by the bottom faces 115a and the protruding parts 117, and the strength against pulling-about of the wires W in this direction is enhanced.

[0028] The present invention includes an embodiment of a socket connector wherein a fitting-on piece and a catching part are not provided. However, in the case of the above-mentioned embodiment, the socket contacts 120 are provided with fitting-on pieces 124 that rise substantially in the height direction from both ends in the width direction, and the faces constituting the wire insertion grooves 115 of the socket housing 110 are provided with catching parts 118 that catch the fitting-on pieces 124 so as to prevent the socket contacts 120 from shifting frontward in the depth direction. With this arrangement, as the catching parts 118 catch the fitting-on pieces 124 and the socket contacts 120 are prevented from shifting frontward in the depth direction, the strength against pulling-out of the wires W is enhanced. Hence it is possible not to adopt the so-called lance structure wherein either the socket housing 110 or the socket contact 120 is provided with a fitting-on piece and the other is provided with a fitting-on hole in which the fitting-on piece is hooked. As a result, it becomes possible to eliminate from the socket housing 110 any fitting-on piece or hole that is formed to make a fitting-on hole, and to make the top face 112 of the socket housing 110 free of any hole, and it becomes possible to reduce the thickness of the socket housing 110.

[0029] The present invention includes embodiments of a socket connector and a header connector, wherein they are arranged so that when the socket connector is connected to the header connector that is mounted on a surface of an object for mounting, the wire insertion grooves of the socket housing are blocked by the object for mounting. However, in the case of the above-mentioned embodiment, the header connector 200 comprises the header connector 210 that is provided with the receiving chamber 214 that penetrates the header housing 210 from the top face 211 being one end face in the height direction to the bottom face 212 being the other end face and extends up to the end face 213 at the front in the depth direction, and header contacts 220 of a blade type that are provided in the header housing 210 so that the contacting parts 221 being formed into plates facing in the width direction protrude from the rear in the depth direction into the receiving chamber 214, the protruding part 119 that fits into the receiving chamber 214 is formed at the rear end in the depth direction of the socket housing 110, the protruding part 119 is provided with receiving

concaved parts 116 in such a way that the receiving concaved parts 116 open to the bottom face 111 and the end face 114 at the rear in the depth direction, and the contacting parts 121 of the socket contacts 120 are so arranged that the contacting parts 121 contact the end faces in the thickness direction of the header contacts 220. With this arrangement, when the socket connector 100 to which the wires W are insulation-displacement-connected is connected to the header connector 200, the protruding part 119 of the socket housing 110 will fit into the receiving chamber 214 of the header housing 210, the bottom face 111 of the socket housing 110 will contact the object for mounting P that is exposed to the receiving chamber 214 of the header housing 210, and the wire insertion grooves 115 will be blocked by the object for mounting P.

[0030] In the case of the above-mentioned embodiment, as the socket connector 100 fits into the head connector 200 in the height direction by using its protruding part 119, there is no need of providing the object for mounting P with an open space for shifting the socket connector 100 at the time of fitting, hence the mounting area is reduced. This is advantageous when the header connector 200 is mounted on a surface of an object for mounting P, the surface having densely mounted components, and the socket connector 100 is to be connected to it. Moreover, when the header connector 200 is mounted on a surface of an object for mounting P, the surface having densely mounted components, and the socket connector 100 is to be fitted into it, the required operation will be pushing the socket connector 100 in the height direction, hence its workability will be significantly improved in comparison with an operation of pushing it in a direction perpendicular to the height direction, such as the depth direction or the width direction. As the wires W of the socket connector 100 are led out of the socket housing 110 in a direction that crosses the height direction, even if, for example, a casing or the like is placed to oppose to the surface of the object for mounting P, the wires will hardly contact the casing. Hence the loads that are exerted to the wires W are reduced and the state of connection is stabilized, and furthermore, the height of the connection structure of both the connectors 100, 200 is reduced. Moreover, as the contacting part 121 of the socket contact 120 is formed into a so-called fork shape and the contacting part 121 contacts the contacting part 221 of the header contact 220 by nipping it from both sides in the thickness direction thereof, the socket contact 120 will contact the header contact 220 at two points, enhancing the reliability of the connection. If the contacting part 121 is formed into a so-called fork shape, the contacting part 121 can be formed of a plate material, and this promotes reduction in the thickness of the socket connector 100.

[0031] The present invention includes embodiments wherein features of the embodiments described above are combined.

Claims

1. A socket connector (110) comprising

when a depth direction, a width direction and a height direction all being perpendicular to each other are assumed, a socket housing (110) that is provided with a wire insertion groove (115), which is concaved in a bottom face (111) being one end face in the height direction toward a top face (112) being the other end and extended up to an end face (113) on the front side in the depth direction, and a receiving concaved part (116), which is located on the rear side in the depth direction of the wire insertion groove (115), is interconnected with the wire insertion groove (115) and opened to the bottom face (111) and into which a header contact (220) of a counterpart header connector (200) being mounted on a surface of an object (P) for mounting is to be inserted, and

a socket contact (120) that is inserted into the wire insertion groove (115) and provided with a contacting part (121) being located at the rear end in the depth direction and set in the receiving concaved part (116) to contact the header contact (220), an insulation barrel (122) being located at the front end in the depth direction, being a plate piece rising substantially in the height direction and being to grip an insulation of a wire (W), and a slot (123) being located between the contacting part (121) and the insulation barrel (122) and being formed by concaving at one end in the height direction of a plate piece rising substantially in the height direction to break the insulation of the wire (W) and make connection with the conductor thereof,

the socket connector (100) being so arranged that when the terminal end of the wire (W) extending in the depth direction is pressed into the wire insertion groove (115) in the height direction to achieve insulation displacement connection with the slot (123), the insulation of the wire (W) is gripped by the insulation barrel (122) and the socket connector (100) is connected to the header connector (200) being mounted on an object (P) for mounting, the wire insertion groove (115) of the socket housing (110) will be blocked by the object (P) for mounting.

2. The socket connector (100) as recited in claim 1, wherein

the socket housing (110) is provided, at the opening of the wire insertion groove (115) on the bottom face side, with protruding parts (117) that protrude inward in the width direction to grip together with the bottom face (115a) of the wire insertion groove (115), with a contact pressure, the socket contact (120) that is

inserted into from the front in the depth direction.

3. The socket connector (100) as recited in claim 1 or claim 2, wherein

the socket contact (120) is provided with fitting-on pieces (124) that rise substantially in the height direction from both ends in the width direction, and

faces constituting the wire insertion groove (115) of the socket housing (110) are provided with catching parts (118) that catch the fitting-on pieces (124) so as to prevent the socket contact (120) from shifting forward in the depth direction.

4. The socket connector (100) as recited in any one of claims 1 to 3, wherein

the header connector (200) comprises a header housing (210) that is provided with a receiving chamber (214) that penetrates the header housing (210) from a top face (211) being one end face in the height direction to a bottom face (212) being the other end face and extends up to an end face (213) at the front in the depth direction, and a header contact (220) of a blade type that is provided in the header housing (210) so that a contacting part (221) being formed into a plate facing in the width direction protrudes from the rear in the depth direction into the receiving chamber (214),

a protruding part (119) that fits into the receiving chamber (214) is formed at the rear end in the depth direction of the socket housing (110), the protruding part (119) is provided with a receiving concaved part (116) in such a way that the receiving concaved part (116) opens to the bottom face (111) and an end face (114) at the rear in the depth direction, and

the contacting part (121) of the socket contact (120) is so arranged that the contacting part (121) contacts an end face in the thickness direction of the header contact (220).

Patentansprüche

1. Steckbuchse (110), die

unter der Annahme, daß eine Tiefenrichtung, eine Breiten- bzw. Querschnittsrichtung und eine Höhenrichtung allesamt zueinander senkrecht sind, ein Steckbuchsengehäuse (110) umfaßt, welches mit einer Draht- bzw. Kabeleinsetznut (115) versehen ist, die in einer Bodenfläche (111), welche eine Endfläche ist, in Höhenrichtung zu einer oberen Fläche (112), welche das

andere Ende bildet, konkav ausgebildet ist und sich bis zu einer Endfläche (113) an der Vorderseite in Tiefenrichtung erstreckt, und ein konkav ausgebildetes Aufnahmeteil (116) umfaßt, welches in Tiefenrichtung an der hinteren Seite der Kabeleinsetznut (115) liegt, mit der Kabeleinsetznut (115) verbunden und zur Bodenfläche (111) hin offen ist, und in welches ein Kopfkontakt (220) eines Kopfverbinder-Gegenstücks (200), das zur Montage an einer Oberfläche eines Objekts (P) befestigt ist, eingesetzt werden soll,

einen Steckbuchsenkontakt (120) umfaßt, der in die Kabeleinsetznut (115) eingesetzt und mit einem Kontakt- bzw. Anschlußteil (121) versehen ist, welches in Tiefenrichtung am hinteren Ende liegt und in das konkav ausgebildete Aufnahmeteil (116) so eingesetzt ist, daß es mit dem Kopfkontakt (220) in Kontakt tritt, wobei ein Isolierzylinder (122) am vorderen Ende in Tiefenrichtung liegt, bei welchem es sich um ein Plattenstück handelt, welches im wesentlichen in Höhenrichtung hochsteht und dazu dient, eine Isolierung eines Kabels (W) zu ergreifen, und wobei ein Schlitz (123) zwischen dem Kontaktteil (121) und dem Isolierzylinder (122) angeordnet ist und durch konkaves Ausbilden an einem Ende in Höhenrichtung eines Plattenstücks gebildet wird, welches im wesentlichen in Höhenrichtung hochsteht, um die Isolierung des Kabels (W) aufzubrechen bzw. zu lösen und mit dessen Leiter in Kontakt zu treten,

wobei die Steckbuchse (100) so angeordnet ist, daß, wenn das Anschlußende des Kabels (W), welches sich in der Tiefenrichtung erstreckt, in die Kabeleinsetznut (115) in Höhenrichtung hineingedrückt wird, um eine die Isolierung verschiebende Verbindung mit dem Schlitz (123) zu erzielen, die Isolierung des Kabels (W) durch den Isolierzylinder (122) ergriffen wird und die Steckbuchse (100) mit dem Kopfkontakt (200) verbunden wird, der zur Montage an einem Objekt (P) befestigt ist, die Kabeleinsetznut (115) des Steckbuchsengehäuses (110) durch das Objekt (P) für die Montage blockiert wird.

2. Steckbuchse (100) nach Anspruch 1, wobei

das Steckbuchsengehäuse (110) an der Öffnung der Kabeleinsetznut (115) an der Seite der Bodenfläche mit vorspringenden Teilen (117) versehen ist, die in Querschnittsrichtung nach innen vorspringen, um zusammen mit der Bodenfläche (115a) der Kabeleinsetznut (115) mit einem Kontaktdruck den Steckbuchsenkontakt (120) zu ergreifen, der von vorne in Tiefenrichtung darin eingesetzt wird.

3. Steckbuchse (100) nach Anspruch 1 oder Anspruch 2, wobei

der Steckbuchsenkontakt (120) mit darauf passenden Teilen (124) versehen ist, die im wesentlichen in der Höhenrichtung von beiden Enden in Querschnittsrichtung hochstehen, und Flächen, die die Kabeleinsetznut (115) des Steckbuchsengehäuses (110) bilden, mit Halte-
5
10
15
20
25
30
35
40
45

4. Steckbuchse (100) nach einem der Ansprüche 1 bis 3, wobei

der Kopfkontakt (200) ein Kopfgehäuse (210) aufweist, welches mit einer Aufnahmekammer (214) versehen ist, die von einer oberen Fläche (211), die eine Endfläche in Höhenrichtung ist, zu einer Bodenfläche (212), die die andere Endfläche ist, durch das Kopfgehäuse (210) verläuft und sich bis zu einer Endfläche (213) an der Vorderseite in Tiefenrichtung erstreckt, und einen Kopfkontakt (220) eines Blatt-Typs aufweist, der in dem Kopfgehäuse (210) vorgesehen ist, so daß ein Anschluß- bzw. Kontaktteil (221) in einer Platte ausgebildet wird, die in Querschnittsrichtung weist, von der Rückseite in Tiefenrichtung in die Aufnahmekammer (214) vorspringt,
ein vorspringender Teil (119), der in die Aufnahmekammer (214) paßt, am hinteren Ende in Tiefenrichtung des Steckbuchsengehäuses (110) ausgebildet ist,
der vorspringende Teil (119) mit einem konkav ausgebildeten Aufnahmeteil (116) so versehen ist, daß das konkav ausgebildete Aufnahmeteil (116) sich zur Bodenfläche (111) und einer Endfläche (114) an der Rückseite in Tiefenrichtung hin öffnet, und
das Kontaktteil (121) des Steckbuchsenkontakts (120) so angeordnet ist, daß das Kontaktteil (121) mit einer Endfläche in Dickenrichtung des Kopfkontakts (220) in Kontakt tritt.

Revendications

1. Connecteur (110) à douille comportant

lorsqu'on suppose une direction de profondeur, une direction de largeur et une direction de hauteur qui sont toutes perpendiculaires entre elles, un corps (110) de douille, qui est pourvu d'une gorge (115) d'insertion de fil, qui est concave dans une face de dessous (111) qui est une pre-
50
55

mière face d'extrémité dans la direction de la hauteur vers une face de dessus (112) qui est l'autre extrémité et qui s'étend jusqu'à une face d'extrémité (113) sur le côté avant dans la direction de la profondeur, et une partie concave (116) de réception, qui est située sur le côté arrière dans la direction de la profondeur de la gorge (115) d'insertion de fil, est interconnectée avec la gorge (115) d'insertion de fil et est ouverte vers la face de dessous (111) et dans lequel un contact (220) d'embase d'un connecteur (200) à embase complémentaire, monté sur une surface d'un objet (P) destiné à un montage, doit être inséré, et

un contact (120) de douille qui est inséré dans la gorge (115) d'insertion de fil et est pourvu d'une partie (121) d'entrée en contact placée à l'extrémité arrière dans la direction de la profondeur et logé dans la partie concave de réception (116) pour entrer en contact avec le contact (220) d'embase, un canon isolant (122) étant placé à l'extrémité avant dans la direction de la profondeur, étant une pièce plate s'élevant sensiblement dans la direction de la hauteur et étant destiné à réaliser une prise sur un isolant d'un fil (W), et une fente (123) située entre la partie d'entrée en contact (121) et le canon (122) pour isolant et étant formée en rendant concave à une extrémité dans la direction de la hauteur une pièce plate s'élevant sensiblement dans la direction de la hauteur pour rompre l'isolant du fil (W) et établir une connexion avec son conducteur,

le connecteur (100) à douille étant agencé de manière que, lorsque l'extrémité terminale du fil (W) s'étendant dans la direction de la profondeur est poussée dans la gorge (115) d'insertion de fil dans la direction de la hauteur pour réaliser une connexion avec déplacement d'isolant avec la fente (123), l'isolant du fil (W) est pris par le canon (122) pour isolant et le connecteur (100) à douille est connecté au connecteur (100) à embase qui est monté sur un objet (P) pour un montage, la gorge (115) d'insertion de fil du corps (110) de la douille est bloquée par l'objet (P) destiné au montage.

2. Connecteur (100) à douille selon la revendication 1, dans lequel

le corps (110) de douille est pourvu, à l'ouverture de la gorge (115) d'insertion de fil sur le côté de la face de dessous, de parties saillantes (117) qui font saillie vers l'intérieur dans la direction de la largeur pour pincer, avec la face de dessous (115a) de la gorge (115) d'insertion de fil, sous une pression de contact, le contact (120) à douille qui y est inséré depuis le côté avant dans la direction de la profondeur.

3. Connecteur (100) à douille selon la revendication 1 ou la revendication 2, dans lequel

le contact à douille (120) est pourvu de pièces rapportées (124) qui s'élèvent sensiblement dans la direction de la hauteur depuis les deux extrémités dans la direction de la largeur, et des faces constituant la gorge (115) d'insertion de fil du corps (110) de douille sont pourvues de parties (118) de retenue qui retiennent les pièces rapportées (124) afin d'empêcher le contact à douille (120) de se décaler vers l'avant dans la direction de la profondeur.

4. Connecteur (100) à douille selon l'une quelconque des revendications 1 à 3, dans lequel

le connecteur (200) à embase comporte un corps (210) d'embase qui est pourvu d'une chambre de réception (214) qui pénètre dans le corps (210) d'embase depuis une face de dessus (211) qui est une première face d'extrémité dans la direction de la hauteur jusqu'à une face de dessous (212) qui est l'autre face d'extrémité et s'élève jusqu'à une face d'extrémité (213) à la partie avant dans la direction de la profondeur, et un contact (220) d'embase d'un type à lame qui est situé dans le corps (210) d'embase afin qu'une partie (221) d'entrée en contact qui est formée dans une plaque faisant face à la direction de la largeur fasse saillie depuis l'arrière dans la chambre (214) de réception, dans la direction de la profondeur, une partie saillante (119) qui s'ajuste dans la chambre (214) de réception est formée à l'extrémité arrière dans la direction de la profondeur du corps (110) de douille, la partie saillante (119) est pourvue d'une partie (116) de réception rendue concave d'une manière telle que la partie (116) de réception rendue concave s'ouvre vers la face de dessous (111) et une face d'extrémité (114) à l'arrière dans la direction de la profondeur, et la partie (121) d'entrée en contact du contact (120) à douille est agencée de façon que la partie (121) d'entrée en contact entre en contact avec une face extrême dans la direction de l'épaisseur du contact (220) d'embase.

50

55

FIG. 3

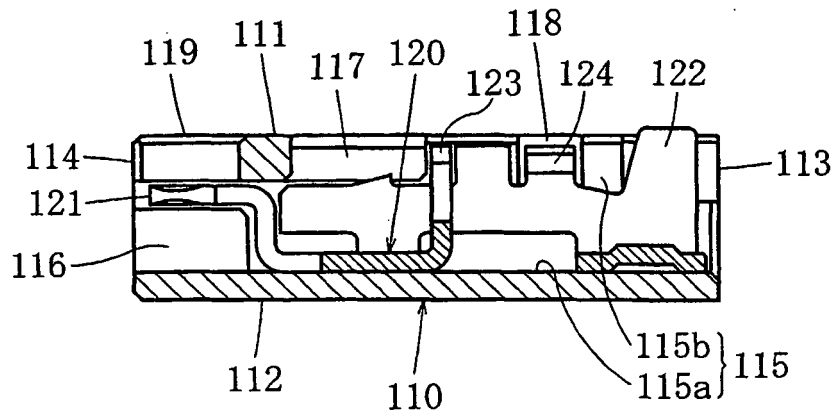

FIG. 4

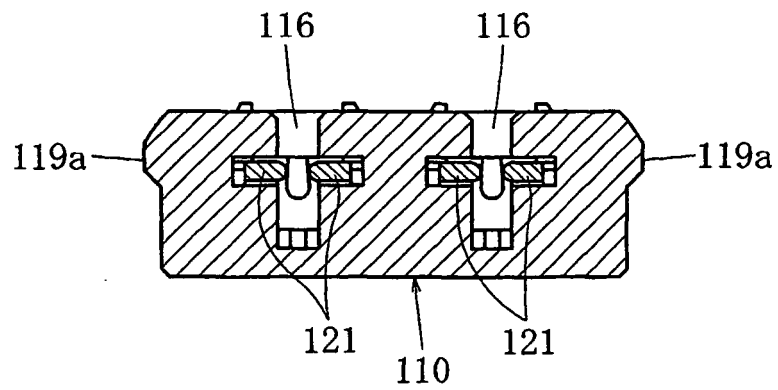

FIG. 5

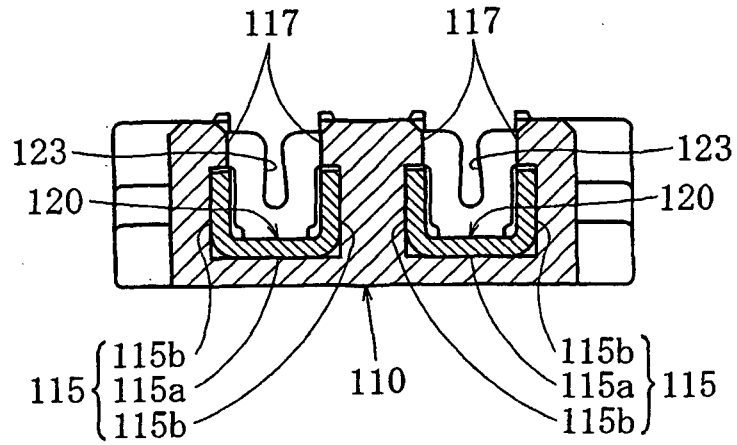

FIG. 6

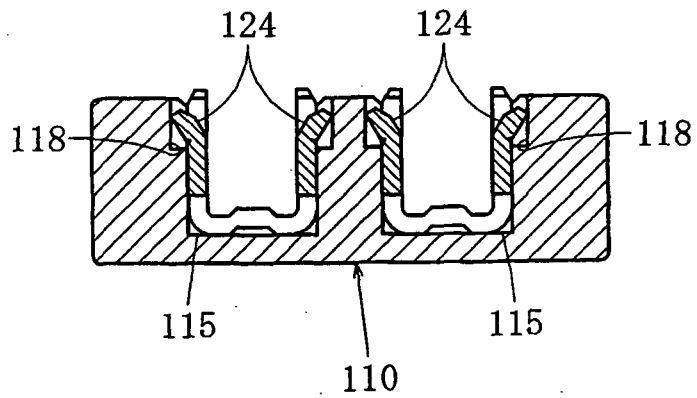

FIG. 7

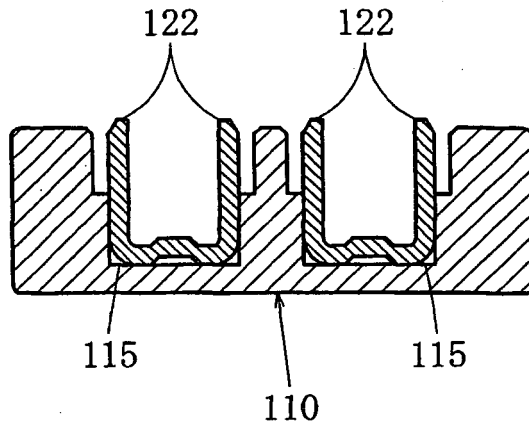

FIG. 8

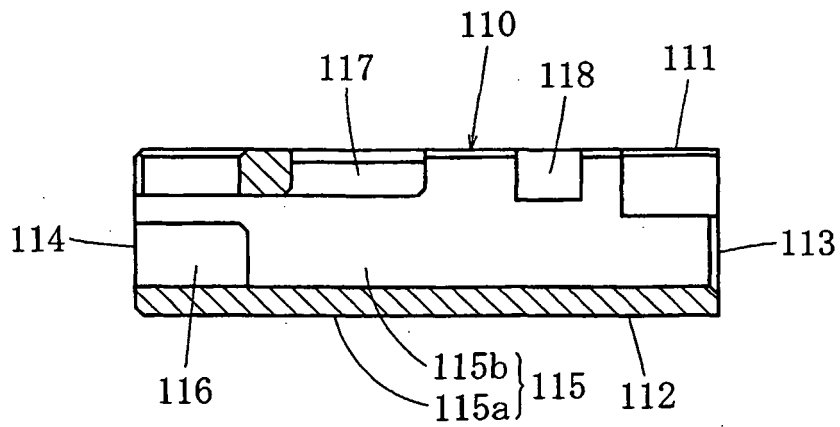

FIG. 9

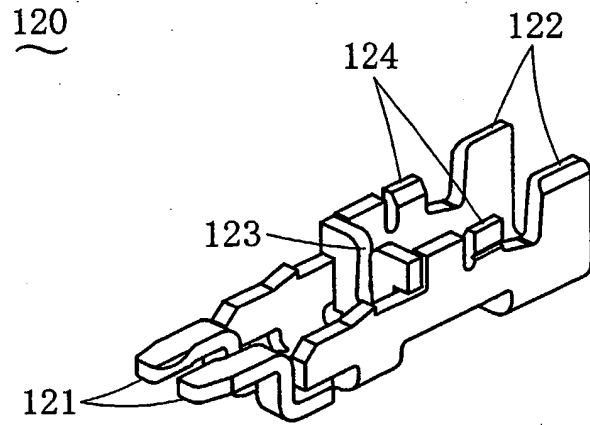

FIG. 10

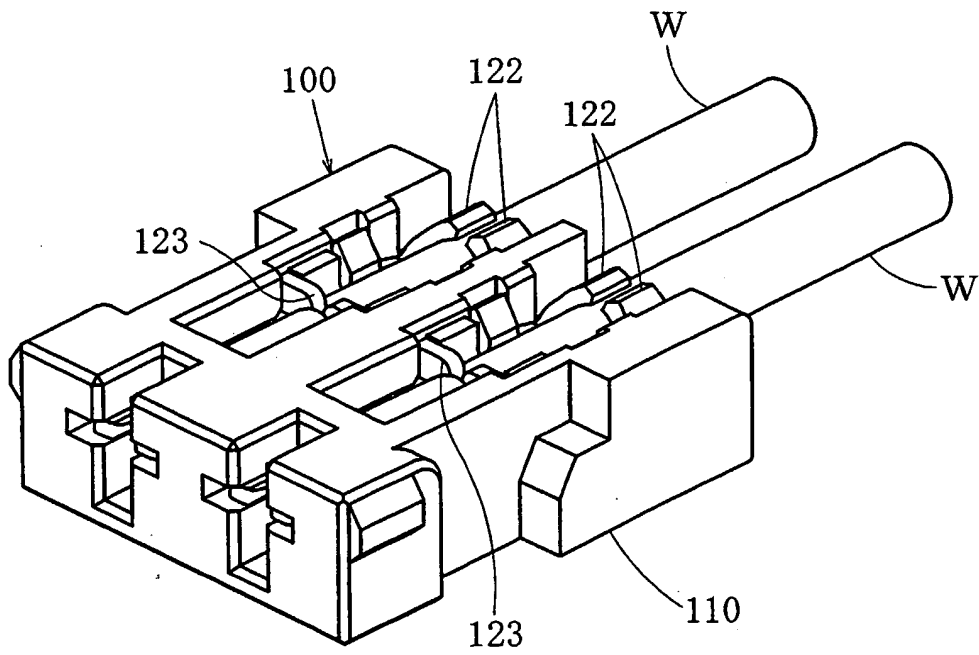

FIG. 11

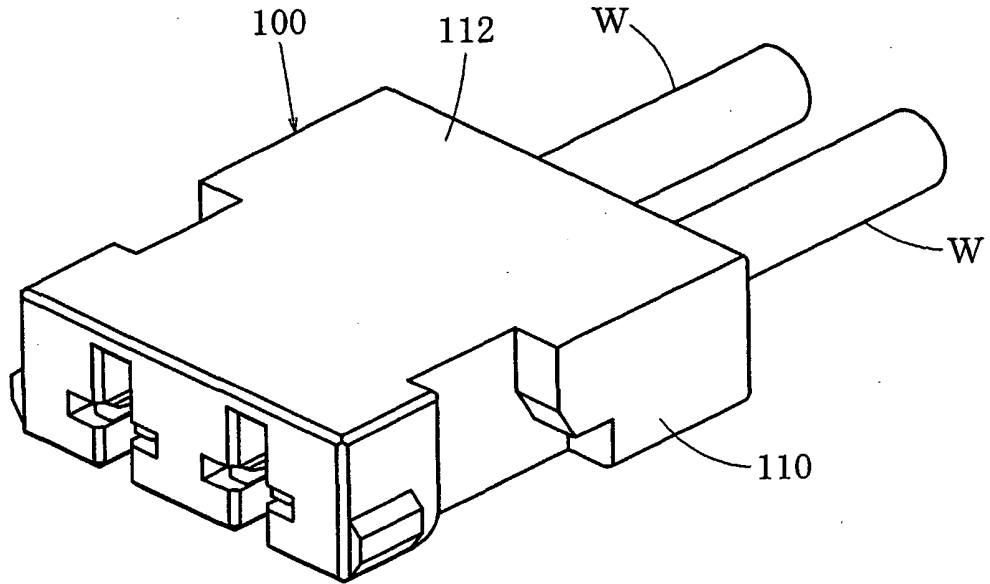

FIG. 12

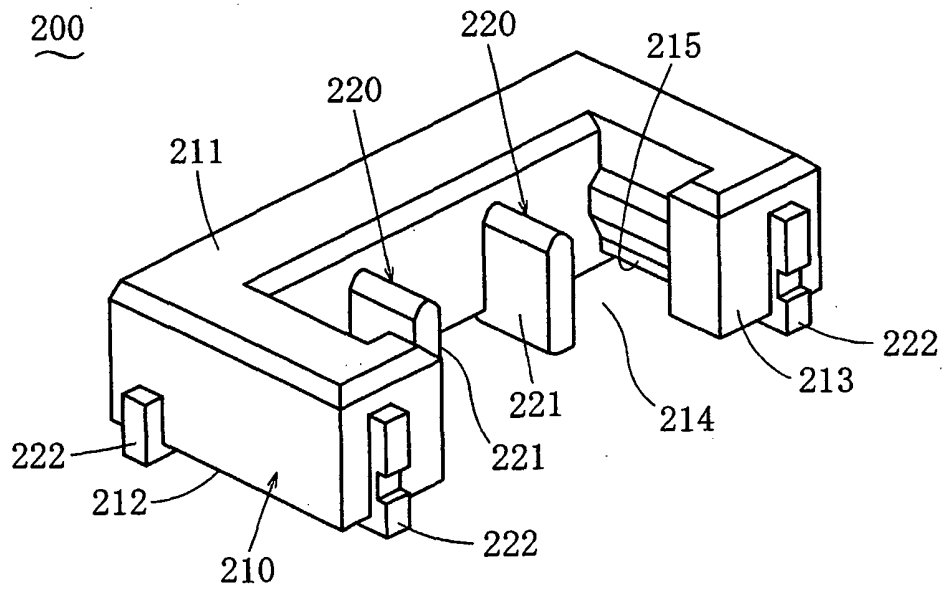

FIG. 13

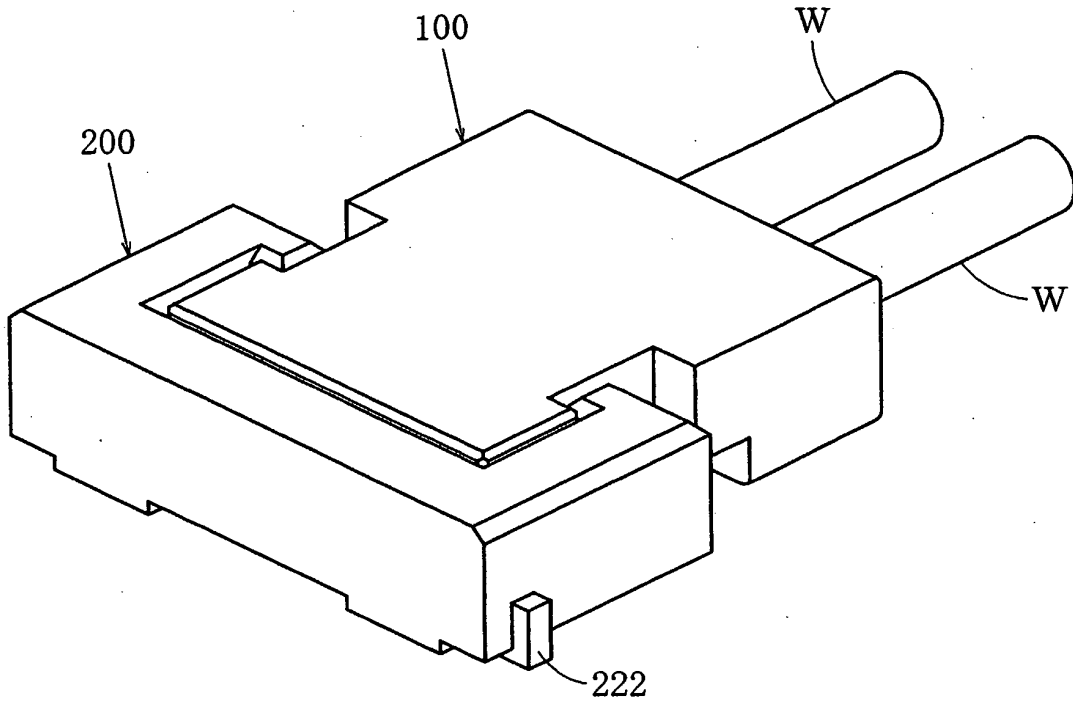

FIG. 14

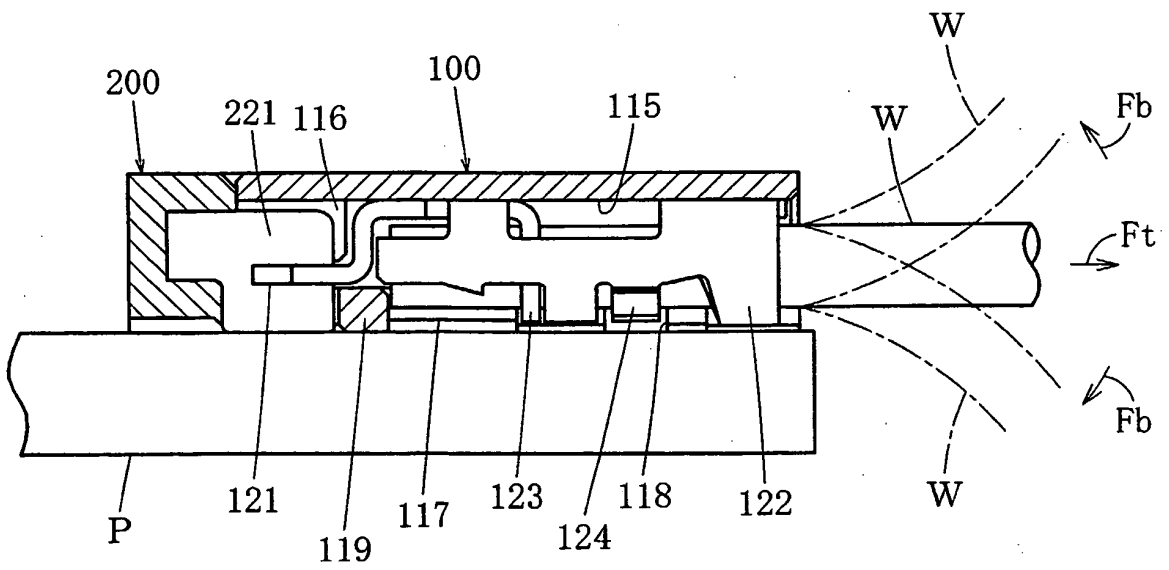
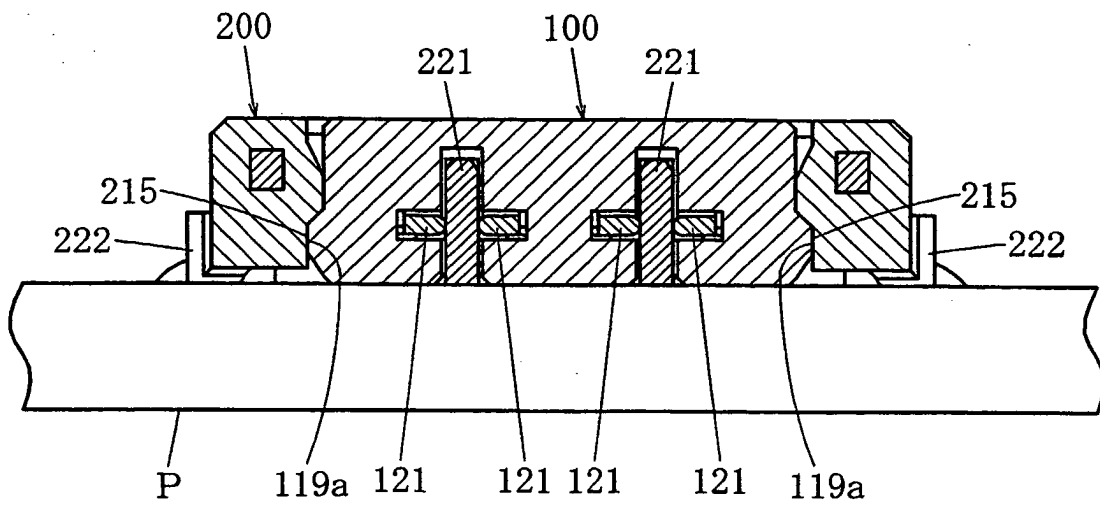

FIG. 15



REFERENCES CITED IN THE DESCRIPTION

This list of references cited by the applicant is for the reader's convenience only. It does not form part of the European patent document. Even though great care has been taken in compiling the references, errors or omissions cannot be excluded and the EPO disclaims all liability in this regard.

Patent documents cited in the description

- JP 3262732 B [0002] [0003]