

(12) INTERNATIONAL APPLICATION PUBLISHED UNDER THE PATENT COOPERATION TREATY (PCT)

(19) World Intellectual Property Organization
International Bureau



(43) International Publication Date
26 June 2003 (26.06.2003)

PCT

(10) International Publication Number
WO 03/052489 A1

(51) International Patent Classification: **G02B 27/28**

(21) International Application Number: PCT/US02/37166

(22) International Filing Date:
19 November 2002 (19.11.2002)

(25) Filing Language: English

(26) Publication Language: English

(30) Priority Data:
01403044.9 27 November 2001 (27.11.2001) EP

(71) Applicant (for all designated States except US): **THOMSON LICENSING S. A.** [FR/FR]; 46 Quai A. Le Gallo, F-92648 Boulogne Cedex (FR).

(72) Inventors; and

(75) Inventors/Applicants (for US only): **DRAZIC, Valter** [FR/FR]; 7 Allee du Pigeon Blanc, F-35830 Betton (FR). **HALL, Estill, Thone, Jr.** [US/US]; 9978 Niagara Drive, Fishers, IN 46038 (US). **O'DONNELL, Eugene, Murphy** [US/US]; 7594 Timber Springs Drive, Fishers, IN 46038 (US).

(74) Agents: **TRIPOLI, Joseph, S.** et al.; c/o Thomson multimedia Licensing Inc., 2 Independence Way, Suite #2, Princeton, NJ 08540 (US).

(81) Designated States (national): AE, AG, AL, AM, AT, AU, AZ, BA, BB, BG, BR, BY, BZ, CA, CH, CN, CO, CR, CU, CZ, DE, DK, DM, DZ, EC, EE, ES, FI, GB, GD, GE, GH, GM, HR, HU, ID, IL, IN, IS, JP, KE, KG, KP, KR, KZ, LC, LK, LR, LS, LT, LU, LV, MA, MD, MG, MK, MN, MW, MX, MZ, NO, NZ, OM, PH, PL, PT, RO, RU, SC, SD, SE, SG, SI, SK, SL, TJ, TM, TN, TR, TT, TZ, UA, UG, US, UZ, VC, VN, YU, ZA, ZM, ZW.

(84) Designated States (regional): ARIPO patent (GH, GM, KE, LS, MW, MZ, SD, SL, SZ, TZ, UG, ZM, ZW), Eurasian patent (AM, AZ, BY, KG, KZ, MD, RU, TJ, TM), European patent (AT, BE, BG, CH, CY, CZ, DE, DK, EE, ES, FI, FR, GB, GR, IE, IT, LU, MC, NL, PT, SE, SK, TR), OAPI patent (BF, BJ, CF, CG, CI, CM, GA, GN, GQ, GW, ML, MR, NE, SN, TD, TG).

Published:

- with international search report
- before the expiration of the time limit for amending the claims and to be republished in the event of receipt of amendments

For two-letter codes and other abbreviations, refer to the "Guidance Notes on Codes and Abbreviations" appearing at the beginning of each regular issue of the PCT Gazette.

(54) Title: POLARIZATION RECYCLER

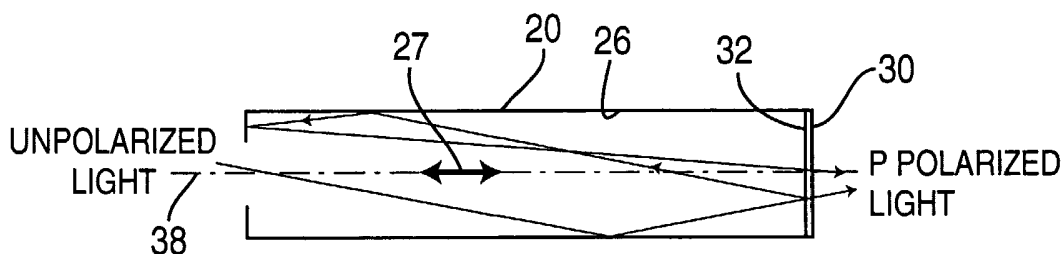

(57) Abstract: A method for recovering polarization comprises the steps of: guiding light having first and second polarizations in a forward direction along a light path (27); passing the guided light having the first polarization out of the path; reflecting the light having the second polarization backwardly and forwardly along the light path; transforming the reflected light during the reflecting step to have the first polarization; and, passing the light transformed to the first polarization out of the path, enabling more of the light having the first polarization to be passed out of the path. The method can be implemented with a light integrator (20), a reflecting polarizer (30), at least one reflective surface (26) that further reflects the reflected light back toward the reflecting polarizer and a quarter wave plate (32) positioned in the light path. The method and apparatus can be used in an illumination system (10) for a liquid crystal display imager (24).



WO 03/052489 A1

POLARIZATION RECYCLER

Background of the Invention5 1. Field of the invention

This invention relates to the field of polarization recycling or recovery systems, and in particular, to the field of polarization recycling or recovery systems adapted for use in illumination system based LCD or LCOS imagers.

10

2. Description of Related Art

LCOS or LCD imagers need polarized light to function properly. In a conventional illumination system for LCD or LCOS imagers, the light is polarized by a sheet polarizer that
15 absorbs one polarization component. There are two undesired effects. The polarizer is overheated and eventually damaged and more than half of the light available for illumination is lost.

Light is polarized if the electrical field associated
20 with a ray is vibrating in one plane, perpendicular to the direction of propagation of the ray. Generally a light ray is randomly polarized, which means that the electric field can vibrate in any direction perpendicular to the direction of propagation. When a randomly polarized light ray hits a
25 reflecting polarizer, for example, the polarizer transmits light that has the electric field vibrating in a first plane perpendicular to the direction of the propagation. The orientation of the plane is determined by the orientation of the polarizer. The polarizer also reflects light that has an
30 electric field that vibrates in a second plane perpendicular to the direction of propagation. The transmitted electric field and the reflected electric field vibrate in planes that are perpendicular one to another. Hence, the reflecting polarizer passes or transmits light having one polarization

and reflects light having a perpendicular, or second, polarization. The plane of polarization can be changed, for example by passing light through a quarter wave plate whose fast axis is at 45° from the orientation of the light ray's polarization. Passing light through two quarter wave plates, or passing light twice through the same quarter wave plate, for example, rotates the polarization plane by 90°.

The state of the art for recycling the polarization involves an array of polarization beam splitters (PBS) either associated with an integrating rod (e.g., Japanese Patent 10232430) or a fly eye lens system. While both means have excellent light throughput and illumination uniformity, there are some significant disadvantages. The price of a PBS array is quite high. Additional optics needed to implement operation a PBS array. PBS arrays require a lot of space, whereas space is often in short supply.

There is an urgent need for a new polarization recovery system that is much simpler and less expensive to implement, that can be implemented without additional lenses or space and that can be substituted into an existing light engine with little, if any, architectural change. Moreover, there is a continuing need for a new polarization recovery or recycling system that avoids thermally damaging polarizers, and at the same time, provides more polarized light for illuminating LCD or LCOS imagers more fully and efficiently.

Summary of the Invention

The inventive arrangements taught herein satisfy the urgent and long-felt needs for a new polarization recovery or recycling system that is much simpler and less expensive to implement, that can be implemented without additional lenses or space, that can be substituted into an existing light engine with little, if any, architectural change, that avoids

thermally damaging polarizers and that provides more polarized light for illuminating LCD or LCOS imagers more fully and efficiently.

In accordance with the inventive arrangements,
5 polarization transforming means, for example a quarter wave plate, can be provided in a light integrator to recycle light originally reflected by the reflecting polarizer. The polarization transforming means can be positioned to enable the reflected light to pass through twice, for example during
10 after back and forth reflections in the light path of the light integrator, thus transforming the reflected light to the correct polarization needed to be passed through the reflective polarizer. Accordingly, the light that is normally lost by being back reflected is recycled, or recovered, by
15 transforming its polarization. The system advantageously exhibits very little losses, and therefore supplies significantly more polarized light more efficiently than prior art systems.

A polarization recovery system in accordance with the
20 inventive arrangements comprises: a light channel; the light channel having a light injection aperture for receiving light from a source of illumination radiating light with first and second polarizations; the light channel having a reflecting polarizer that transmits the injected light having the first
25 polarization and that reflects the injected light having the second polarization; at least one reflective surface for further reflecting the reflected light back toward the reflecting polarizer; and, means positioned in the light channel for transforming the light reflected by the reflecting
30 polarizer into light having the first polarization, the transformed light also being transmitted by the reflecting polarizer.

A method for recovering polarization in an illumination system for a liquid crystal display, in accordance with the inventive arrangements, comprises the steps of: guiding light having first and second polarizations in a forward direction along a light path; passing the guided light having the first polarization out of the path; reflecting the light having the second polarization backwardly and forwardly along the light path; transforming the reflected light during the reflecting step to have the first polarization; and, passing the light transformed to the first polarization out of the path, enabling more of the light having the first polarization to be passed out of the path.

An illumination system for a liquid crystal imager, comprising: a source of randomly polarized light; a light integrator having an aperture at one end for receiving the randomly polarized light and having reflective surfaces defining an internal light path; a reflecting polarizer disposed at an opposite end of the light path that transmits light having a first polarization and that reflects light having a second polarization, the light having the second polarization being reflected back and forth along the light path; and, means positioned in the light channel for transforming the back and forth reflected light into light having the first polarization, the transformed light also being transmitted by the reflecting polarizer. A liquid crystal imager can be more efficiently illuminated by both components of the light transmitted by the reflecting polarizer and having the first polarization.

Brief Description of the Drawings

Figure 1 illustrates the general operating principle of the integrating light pipe, or rod.

Figures 2(a) and 2(b) are useful for explaining how to choose the size of the integrating light pipe, or rod.

Figures 3(a) and 3(b) are useful for explaining injection of the source into the integrating light pipe, or rod.

5 Figures 4(a), 4(b), 4(c) and 4(d) illustrate four embodiments for recovering polarization in accordance with the inventive arrangements.

Figure 5 is a simulation generated waveform useful for explaining the efficiency of the inventive arrangements.

10

Detailed Description of the Preferred Embodiments

An illumination system 10 in accordance with the inventive arrangements and adapted for use with a liquid crystal imager, for example an LCD or LCOS (liquid crystal on silicon) imager, is shown in Figure 1. A source 12 of randomly polarized light radiates outwardly toward an elliptical reflector 14, which focuses an image 16 of the light at the entrance aperture 18 of a light channel 20 for controlling the propagation of light there through. The light channel 20 can be embodied as a light integrator, for example an integrating light rod. Uniform light at the opposite end 22 of the light rod is radiated onto a liquid crystal display imager 24.

25 The principle of the integrating rod for the illumination system is well established and widely used. It's functionality is twofold: beam shaping from round to rectangular and illumination uniformity. The light coming out of a source is focused at the input side of an integrating rod. The light bounces into the rod by either reflecting from its mirrored sides or by total internal reflection if the rod is made out of glass. At the end of the rod, the illumination is uniform. The rod having a cross section of the same ratio than the imager, it's output side can be imaged onto a LCOS or

30

LCD imager with a lens system. Hence the illumination is uniform and very efficient because of the format conversion between the collecting means (reflector) and imager. If polarized light is needed for the imager, more than half of the available light will be lost by polarizing the illumination unless polarization is achieved by a means that recycles one of the components.

An integrating rod forming the light channel 20 is shown in Figure 2, with interior reflective walls 26. The mirrored side walls define a light path 27 between the aperture and the reflecting polarizer 30, as shown in Figures 4(a) - 4(d). The reflecting polarizer is a means for transforming the polarization of light. Figures 2(a) and 2(b) show how the size of the integrating rod can be optimally chosen to be big enough for the image of the source to be injecting efficiently into the integrator. If the input surface of the integrator is a reflecting surface with a light injection aperture or hole 18 that is big enough to inject enough light into the integrator, as shown in Figures 3(a) and 3(b), it is easy to put a reflecting polarizer at the end of the integrator. That polarizer is going to let one component through, p polarized light for instance, while reflecting back into the integrator the other component (the s component for instance). As the s polarized light arrives again at the input side of the integrator, some of it will be reflected back into the integrator, some of it will leak out through the hole. The s-polarized component that has been reflected back into the light pipe should have its polarization rotated before it can go through the reflecting polarizer the second time it reaches it.

Figures 4(a) - 4(d) show four embodiments as to how the inventive arrangements can be implemented. In the embodiment shown in Figure 4(a), the reflecting polarizer 30 is a Proflux

brand from the Moxtek company, one of the very few reflecting polarizers known to work when arranged perpendicularly to the longitudinal axis 38 of the integrating rod and the light path 27 defined therein. The light reflected by the polarizer is recycled or recovered by passing twice through a means for transforming polarization embodied as a quarter wave plate 32, which in Figure 4(a) is disposed at the same end of the light path 27 as the reflecting polarizer.

The quarter wave plate can also be located near the input port or aperture 18 of the light integrator, as shown in Figure 4(b). Placing the quarter wave plate at the end of the light path opposite to the reflecting polarizer has the advantage of attenuating less light than at the output port; and thus is the preferred embodiment as between Figures 4(a) and 4(b).

Figures 4(c) and 4(d) show alternative systems for reflecting the polarization. The mirrored surfaces 26 of the light integrator can be a dielectric coating that does not rotate the polarization, for example a Silflex brand coating from the Unaxis company. The integrator can also be a rod made out of glass. Then, the output reflecting polarizer is effectively glued or otherwise adhered to the output port. In Figures 4(c) and 4(d) the reflecting polarizer is an assembly, as opposed to the single optical device in Figures 4(a) and 4(b). In Figure 4(c) the assembly includes separate parts, namely a mirror 34 and a polarized beam splitter 36 disposed at 45° to the axis 38 of the light path 27. In Figure 4(d) the assembly also includes two parts, two polarized beam splitters 40 each disposed at 45° to the axis of the light path 27, and at an angle of 90° with respect to one another.

The light injection aperture on the input side of the light path can be made by a reflecting coating having a hole. A retardation film 42 is disposed in the light path 27, either

between the output surface of the rod and the reflecting polarizer or at its input. The film is represented by a dashed line, disposed near the input end of the light path in Figures 4(c) and disposed near the output of the light path in Figure 4(d). The positions of the film can be reversed, input end to output end and output end to input end, in each of Figures 4(c) and 4(d).

A system in accordance with the inventive arrangements has been simulated with ASAP according to the following conditions. The lamp is a Radiant imaging 16 bit model of a widely used high pressure discharge lamp. The reflector is elliptical and focuses light into an integrator that has an input size of 11.08 x 6.23 mm. The sides of the integrator reflect 98% of the light, regardless of the angle of incidence, the polarization and the wavelength (Silflex mirror). The reflecting polarizer is a Proflux brand from Moxtek with a transmission of 85% of the p polarization. It reflects the s polarization, which is recycled by a quarter wave plate located at the input side of the integrator with an efficiency of 85%. The size of the injection aperture has been varied and the efficiency of the system plotted against the radius of the aperture. The graph in Figure 5 shows that there is an optimal size of 3.25 mm radius and that the efficiency for this size of injection aperture is of 0.472. This aperture is the best tradeoff between injection efficiency and recycling. If it is smaller, there is less light injected into the light pipe. If it is bigger, there is more s-polarized light leaking through after reflection onto the Moxtek polarizer. If the radius grows above the size of the semi diagonal of the input port of the integrator, an efficiency is reached that the illumination system would have without the recycling. On the graph, this is read from radius of apertures above 6.33 mm and found to be 0.323. Hence the

gain that can be expected for this geometry is $G = 0.472/0.323 = 1.46$, which is a very good value.

Significant advantages of this system compared to those based on a linear array of PBS's are the extreme compactness and the fact that the system can easily fit into already existing designs without much change in the geometry, since the system does not require extra optical means aside from a relay lens system to image the output of the integrator onto the imager. Moreover, such a relay system is already implemented in a system using an integrating light pipe. Better gains can be achieved with light sources that have a smaller burner than the one used in this simulation case, which had a gap of 1.3 mm. The system also has cost advantages, since there are only a few new parts added, and no major tooling is needed, as would be the case for fly's eye lens and PBS arrays.

In Figure 5 the maximum value of 1 is the total light flux of the source. Above a radius of 6.33 mm, the output is steady because the injection hole is bigger than the input size of the integrator. Hence there is no polarization recycling. The efficiency is then about 32.3%. This means that 32.3% of the light emitted by the source is available for illuminating the imagers and is polarized. With recycling, the best value is achieved for a radius of 3.25 mm and peaks at 47.2% of polarized light, which is a gain of 46%.

What is claimed is:

1. A polarization recovery system, comprising:
a light channel (20);
said light channel having a light injection aperture (18)
for receiving light from a source (12) of illumination
radiating light with first and second polarizations (e.g., p
and s);
said light channel having a reflecting polarizer (30)
that transmits said injected light having said first
polarization and that reflects said injected light having said
second polarization;
at least one reflective surface (26) for further
reflecting said reflected light back toward said reflecting
polarizer; and,
means (32) positioned in said light channel for
transforming said light reflected by said reflecting polarizer
into light having said first polarization, said transformed
light also being transmitted by said reflecting polarizer.
2. The polarization recovery system of claim 1, wherein
said light channel is defined by inwardly facing reflective
surfaces, including said at least one reflective surface.
3. The polarization recovery system of claim 2, wherein
said transforming means comprises a quarter wave plate.
4. The polarization recovery system of claim 1, wherein
said transforming means comprises a quarter wave plate.
5. The polarization recovery system of claim 4, wherein
said light channel forms part of a light integrator.

6. The polarization recovery system of claim 1, wherein said light channel forms part of a light integrator.

7. The polarization recovery system of claim 2, wherein said light channel forms part of a light integrator.

8. The polarization recovery system of claim 3, wherein said light channel forms part of a light integrator.

9. The polarization recovery system of claim 1, wherein said aperture and said reflecting polarizer are disposed at opposite ends of said light channel.

10. The polarization recovery system of claim 8, wherein said aperture and said reflecting polarizer are disposed at opposite ends of said light channel.

11. The polarization recovery system of claim 1, wherein said reflecting polarizer and said quarter wave plate are at the same end of said light channel.

12. The polarization recovery system of claim 8, wherein said reflecting polarizer and said quarter wave plate are at the same end said light channel.

13. The polarization recovery system of claim 1, wherein said aperture and said quarter wave plate are at the same end of said light channel.

14. The polarization recovery system of claim 8, wherein said aperture and said quarter wave plate are at the same end of said light channel.

15. The polarization recovery system of claim 1, wherein said reflecting polarizer comprises a single optical device that both reflects light and transmits polarized light.

16. The polarization recovery system of claim 1, wherein said reflecting polarizer comprises:

a mirror disposed parallel to a longitudinal axis of the light path; and,

a polarized beam splitter disposed at an angle of 45° with respect to said axis.

17. The polarization recovery system of claim 1, wherein said reflecting polarizer comprises first and second polarized beam splitters, each disposed at an angle of 45° with respect to a longitudinal axis of the light path, and disposed at an angle of 90° with respect to one another.

18. A method for recovering polarization in an illumination system (10) for a liquid crystal display imager (24), comprising the steps of:

guiding light having first and second polarizations in a forward direction along a light path (27);

passing said guided light having said first polarization out of said path;

reflecting said light having said second polarization backwardly and forwardly along said light path;

transforming said reflected light during said reflecting step to have said first polarization; and,

passing said light transformed to said first polarization out of said path, enabling more of said light having said first polarization to be passed out of said path.

19. The method of claim 18, further comprising the step of integrating said light in said light path during said guiding and reflecting steps.

20. The method of claim 18, comprising the step of transforming said polarization of said reflected light in one-quarter wave increments.

21. An illumination system for a liquid crystal imager, comprising:

a source of randomly polarized light (12);

a light integrator (20) having an aperture (18) at one end for receiving said randomly polarized light and having reflective surfaces (26) defining an internal light path (27);

a reflecting polarizer (30) disposed at an opposite end of said light path that transmits light having a first polarization and that reflects light having a second polarization, said light having said second polarization being reflected back and forth along said light path; and,

means (32) positioned in said light path for transforming said back and forth reflected light into light having said first polarization, said transformed light also being transmitted by said reflecting polarizer.

22. The system of claim 21, comprising a liquid crystal imager illuminated by both components of said light transmitted by said reflecting polarizer and having said first polarization.

23. The system of claim 21, wherein said transforming means comprises a quarter wave plate.

24. The system of claim 21, wherein said transforming means and said reflecting polarizer are disposed at the same end of the light path.

25. The system of claim 21, wherein said aperture and said transforming means are disposed at the same end of the light path.

1/3

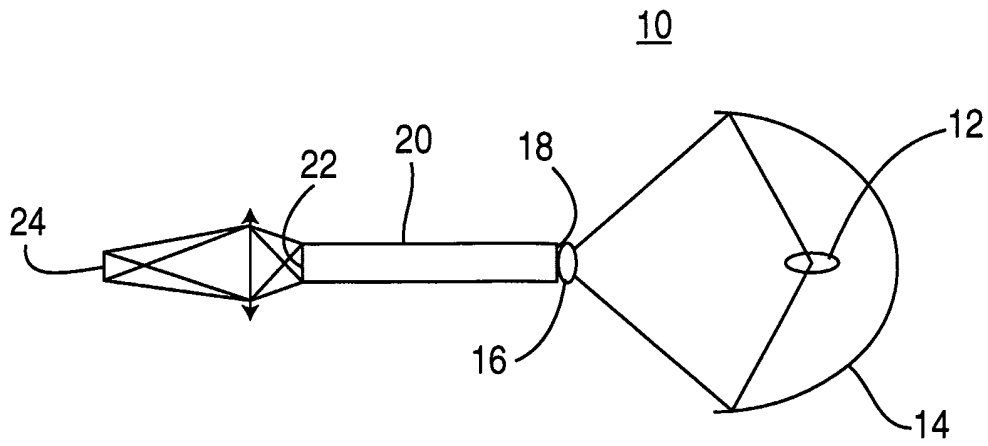

FIG. 1

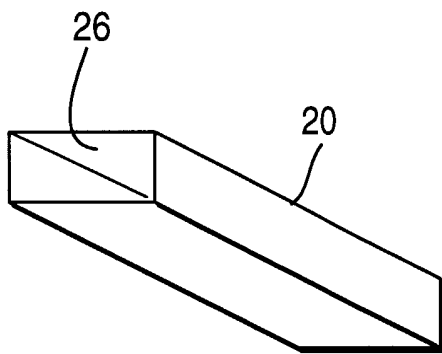

FIG. 2a

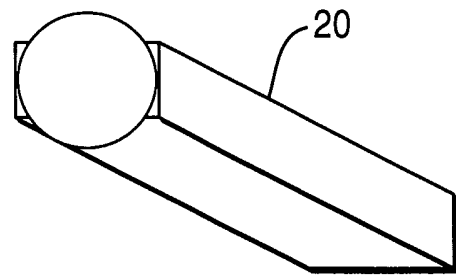

FIG. 2b

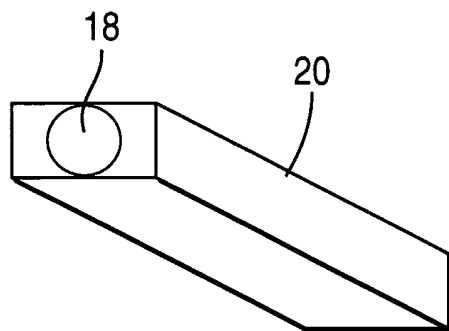

FIG. 3a

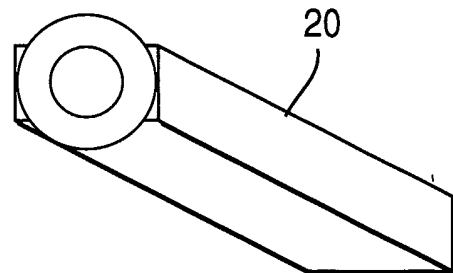

FIG. 3b

2/3

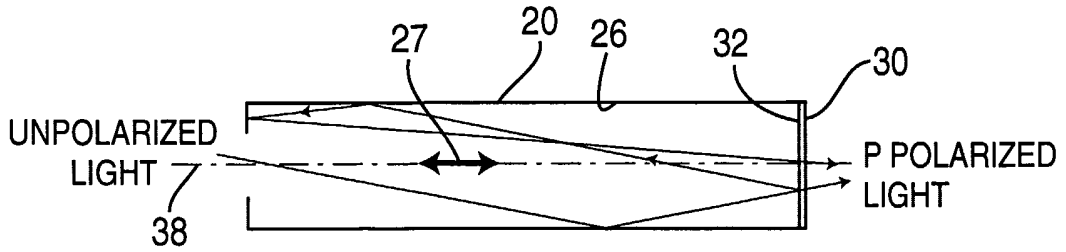

FIG. 4a

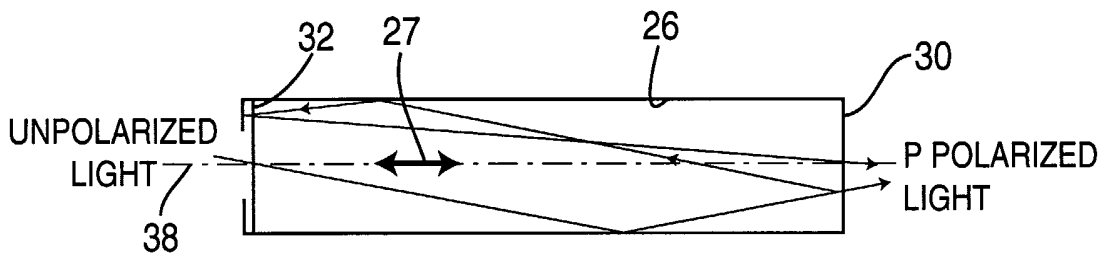

FIG. 4b

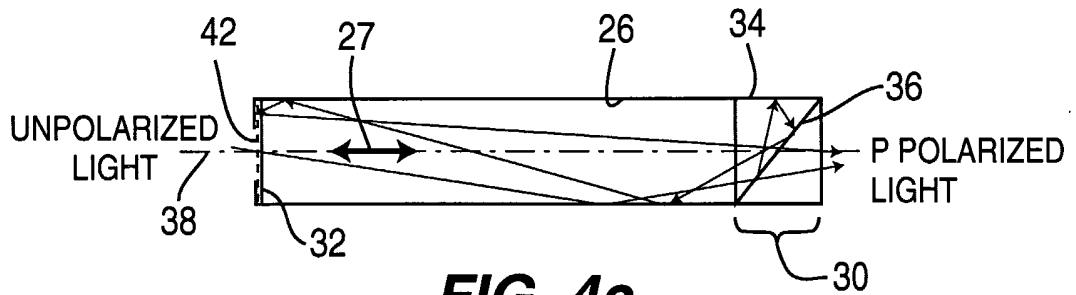

FIG. 4c

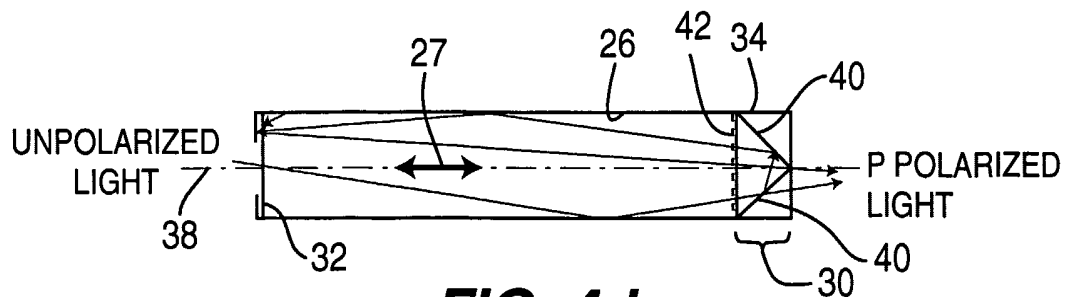

FIG. 4d

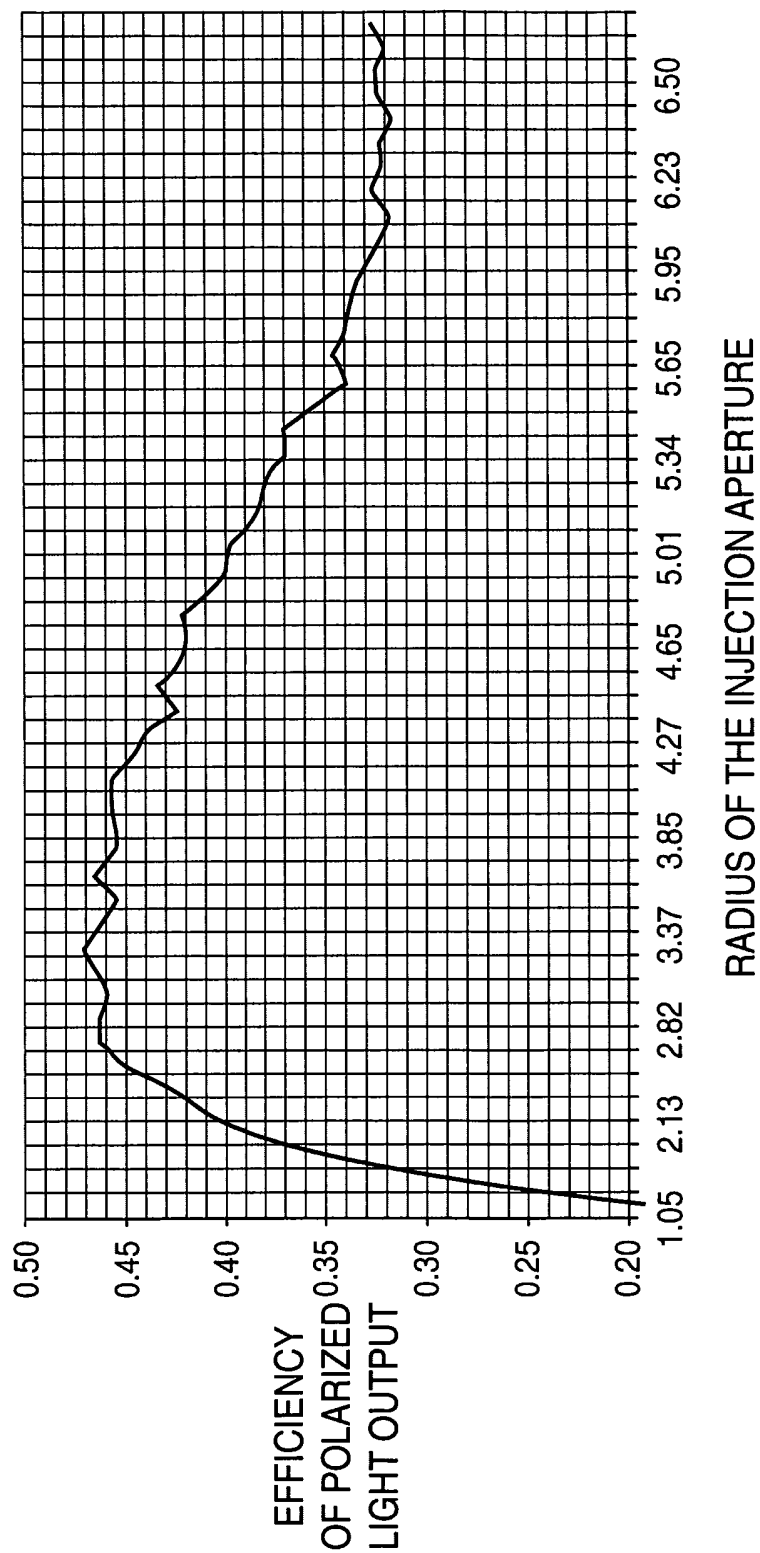

FIG. 5

INTERNATIONAL SEARCH REPORT

Int'l Application No
PCT/US 02/37166

A. CLASSIFICATION OF SUBJECT MATTER
IPC 7 G02B27/28

According to International Patent Classification (IPC) or to both national classification and IPC

B. FIELDS SEARCHED

Minimum documentation searched (classification system followed by classification symbols)
IPC 7 G02B

Documentation searched other than minimum documentation to the extent that such documents are included in the fields searched

Electronic data base consulted during the international search (name of data base and, where practical, search terms used)

EPO-Internal

C. DOCUMENTS CONSIDERED TO BE RELEVANT

Category *	Citation of document, with indication, where appropriate, of the relevant passages	Relevant to claim No.
X	US 2001/028423 A1 (NAGATA HIDEKI ET AL) 11 October 2001 (2001-10-11) abstract paragraph '0039! figures 6-10	1-15, 18-25
A	---	16, 17
X	US 6 208 463 B1 (GUNTHER JOHN ET AL) 27 March 2001 (2001-03-27) abstract; figures	1-4, 9, 11, 15, 16, 18, 20
A	---	5-8, 10, 12, 17, 19, 21-24
	---	-/--

Further documents are listed in the continuation of box C.

Patent family members are listed in annex.

* Special categories of cited documents:

A document defining the general state of the art which is not considered to be of particular relevance

E earlier document but published on or after the international filing date

L document which may throw doubts on priority claim(s) or which is cited to establish the publication date of another citation or other special reason (as specified)

O document referring to an oral disclosure, use, exhibition or other means

P document published prior to the international filing date but later than the priority date claimed

T later document published after the international filing date or priority date and not in conflict with the application but cited to understand the principle or theory underlying the invention

X document of particular relevance; the claimed invention cannot be considered novel or cannot be considered to involve an inventive step when the document is taken alone

Y document of particular relevance; the claimed invention cannot be considered to involve an inventive step when the document is combined with one or more other such documents, such combination being obvious to a person skilled in the art.

& document member of the same patent family

Date of the actual completion of the international search

8 April 2003

Date of mailing of the international search report

16/04/2003

Name and mailing address of the ISA

European Patent Office, P.B. 5818 Patentlaan 2
NL - 2280 HV Rijswijk
Tel. (+31-70) 340-2040, Tx. 31 651 epo nl,
Fax: (+31-70) 340-3016

Authorized officer

Seibert, J

INTERNATIONAL SEARCH REPORT

Application No
PCT/US 02/37166

C.(Continuation) DOCUMENTS CONSIDERED TO BE RELEVANT		
Category °	Citation of document, with indication, where appropriate, of the relevant passages	Relevant to claim No.
X A	US 6 101 032 A (JONZA JAMES M ET AL) 8 August 2000 (2000-08-08) abstract column 5, line 21 - line 36 figures 1-6	1,2,6,7, 15,17,18
X A	----- US 6 064 523 A (BUDD RUSSELL ALAN ET AL) 16 May 2000 (2000-05-16) abstract; figures 2,3A,6A,7A,8A,9A,10	3-5, 8-14,16, 19-25
X A	----- US 6 064 523 A (BUDD RUSSELL ALAN ET AL) 16 May 2000 (2000-05-16) abstract; figures 2,3A,6A,7A,8A,9A,10	1-4,9, 13,15, 16,18,20
E	----- WO 03 019246 A (EDLINGER JOHANNES ; HEINE-KEMPKENS CLAUS (CH); UNAXIS BALZERS AG (L) 6 March 2003 (2003-03-06) abstract; figures 4,5,7	5-8, 10-12, 14,17, 19,21-25
A	----- US 5 884 991 A (GOURLEY HELEN ET AL) 23 March 1999 (1999-03-23) abstract; figures 2-4,7-9	1-25
A	----- US 6 206 532 B1 (HAWES EDWARD MAXWELL) 27 March 2001 (2001-03-27) abstract; figures -----	1-25

INTERNATIONAL SEARCH REPORT

Information on patent family members

International Application No

PCT/US 02/37166

Patent document cited in search report		Publication date	Patent family member(s)	Publication date
US 2001028423	A1	11-10-2001	JP 9146063 A	06-06-1997
			JP 3269362 B2	25-03-2002
			JP 9146064 A	06-06-1997
			JP 9146065 A	06-06-1997
			US 6331879 B1	18-12-2001
US 6208463	B1	27-03-2001	AU 4071299 A	29-11-1999
			CN 1307689 T	08-08-2001
			EP 1086390 A1	28-03-2001
			JP 2002514781 T	21-05-2002
			NO 20005734 A	03-01-2001
			WO 9959008 A1	18-11-1999
US 6101032	A	08-08-2000	US 6396631 B1	28-05-2002
			AU 2242295 A	30-10-1995
			CA 2187177 A1	19-10-1995
			DE 69527515 D1	29-08-2002
			EP 0754311 A1	22-01-1997
			JP 9511844 T	25-11-1997
			WO 9527919 A2	19-10-1995
US 6064523	A	16-05-2000	NONE	
WO 03019246	A	06-03-2003	WO 03019246 A1	06-03-2003
			US 2003007245 A1	09-01-2003
US 5884991	A	23-03-1999	US 5829858 A	03-11-1998
			US 5902033 A	11-05-1999
US 6206532	B1	27-03-2001	AU 4568097 A	15-05-1998
			WO 9818040 A1	30-04-1998