



INTERNATIONAL APPLICATION PUBLISHED UNDER THE PATENT COOPERATION TREATY (PCT)

<p>(51) International Patent Classification³ : G06F 15/31</p>	<p>A1</p>	<p>(11) International Publication Number: WO 84/ 03159 (43) International Publication Date: 16 August 1984 (16.08.84)</p>
<p>(21) International Application Number: PCT/US84/00141 (22) International Filing Date: 1 February 1984 (01.02.84) (31) Priority Application Number: 463,613 (32) Priority Date: 3 February 1983 (03.02.83) (33) Priority Country: US (71) Applicant: RCA CORPORATION [US/US]; P.O. Box 432, Princeton, NJ 08540 (US). (72) Inventors: BERNARD, Francis, Selwyn ; 775 E. 46 Street, Brooklyn, NY 11203 (US). ELISCU, Steven, Michael ; 2401 Logan Road, Ocean, NJ 07712 (US). BATTERMAN, Eric, Paul ; 112 Forest Road, Cherry Hill, NJ 08034 (US). (74) Agents: WHITACRE, Eugene, M. et al.; RCA Corporation, Patent Operations, P.O. Box 432, Princeton, NJ 08540 (US).</p>		<p>(81) Designated States: AT (European patent), DE (European patent), FR (European patent), GB (European patent), JP. Published <i>With international search report.</i></p>

(54) Title: APPARATUS FOR GENERATING SCALED WEIGHTING COEFFICIENTS FOR SAMPLED DATA FILTERS

(57) Abstract

Method and apparatus for generating continuously variable sets of weighting coefficients for application to weighting circuits of a sampled data filter. A set standard weighting coefficients are predetermined to produce a nominal desired frequency response (Fig. 1a). The variable coefficients are generated by piecewise linear interpolation of the standard filter impulse response at points in time corresponding to the relative time position of the standard coefficients multiplied by a scale factor. Apparatus for performing the method includes a means (18) for storing the standard coefficients in an indexed manner. Means (12) are also provided for generating a sequence of numbers corresponding to the index values. The sequence of numbers are multiplied in a multiplier (15) by a scale factor supplied at a terminal (SCALE FACTOR SOURCE). The scaled coefficients are calculated according to an equation in a calculating means (22, 24, 25, 26) and means (33) are provided for storing the scaled coefficients.

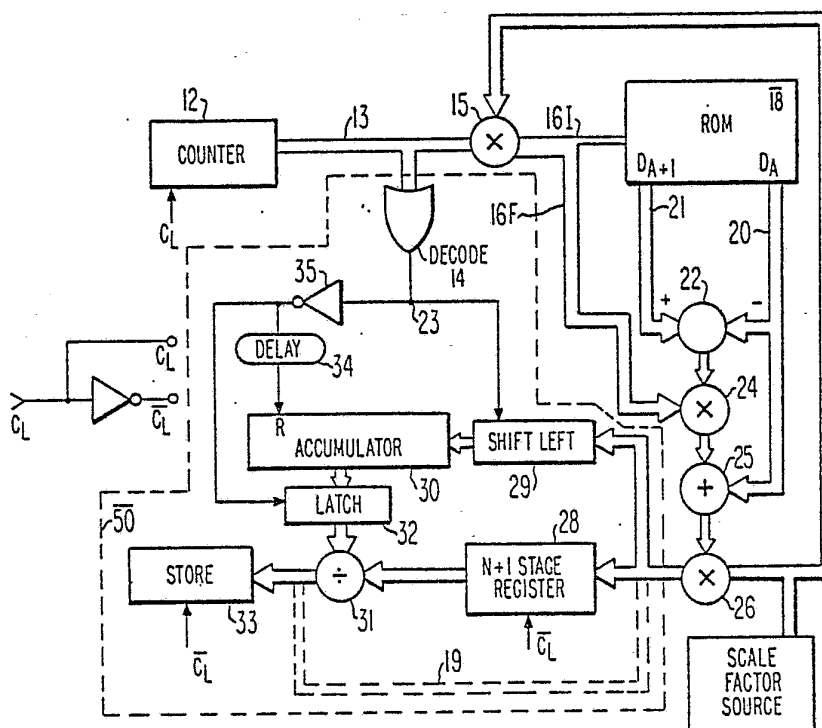

FOR THE PURPOSES OF INFORMATION ONLY

Codes used to identify States party to the PCT on the front pages of pamphlets publishing international applications under the PCT.

AT	Austria	KR	Republic of Korea
AU	Australia	LI	Liechtenstein
BE	Belgium	LK	Sri Lanka
BG	Bulgaria	LU	Luxembourg
BR	Brazil	MC	Monaco
CF	Central African Republic	MG	Madagascar
CG	Congo	MR	Mauritania
CH	Switzerland	MW	Malawi
CM	Cameroon	NL	Netherlands
DE	Germany, Federal Republic of	NO	Norway
DK	Denmark	RO	Romania
FI	Finland	SD	Sudan
FR	France	SE	Sweden
GA	Gabon	SN	Senegal
GB	United Kingdom	SU	Soviet Union
HU	Hungary	TD	Chad
JP	Japan	TG	Togo
KP	Democratic People's Republic of Korea	US	United States of America

APPARATUS FOR GENERATING SCALED WEIGHTING
COEFFICIENTS FOR SAMPLED DATA FILTERS

Background of the Invention

5 This invention relates to adaptive filters and more particularly to apparatus for generating weighting coefficients for sampled data filters such as finite impulse response filters.

10 Sampled data filters perform weighting and summing operations on successive input samples to produce filtered replicas, $y(n)$, of the input samples, $x(n)$, generally defined by the equation

$$15 \quad y(n) = \sum_{i=0}^k a_i x(n-i) - \sum_{i=1}^k b_i y(n-i).$$

20 The factors a_i and b_i are weighting coefficients applied to delayed input and output samples $x(n-i)$ and $y(n-i)$, respectively, where i connotes the number of sample delay periods. The equation defines the transfer function of a recursive filter. If the rightmost term of the equation is eliminated, the equation defines the transfer function of a non-recussive filter.

25 It will readily be appreciated that the transfer function of a given filter can be altered by changing the value of the weighting coefficients a_i and b_i . If apparatus is provided to automatically change the filter weighting coefficients in response to some stimulus, the filter transfer function is advantageously made adaptive.
30 For example, sets of weighting coefficients may be stored in a read only memory (ROM). The stimulus may be arranged to address the ROM to provide particular sets of the coefficients to the filter weighting elements, which coefficients would correspond to particular values of the
35 stimulus. If the stimulus corresponds to the frequency content of the signal being processed by the filter, the bandwidth of the filter can be varied responsive to the signal frequency content to enhance the average signal-to-noise ratio.



ROM's are a convenient media for storing and accessing sets of weighting coefficients in adaptive filter circuits. However, if the desired range of filter adaptability is relatively wide and is to be incremented with relatively fine resolution, the size of the ROM may become excessive. For a filter having 15 taps, i.e., 15 weighting circuits, with each weighting coefficient consisting of a six bit binary number, one set of coefficients requires 90 bit locations in the ROM. As few as eleven sets of coefficients will require over 1,000 bit locations and will provide relatively course vernier resolution.

It is an object of the present invention to generate sets of weighting coefficients which are substantially continuously variable with relatively simple hardware making possible adaptive filters which are substantially continuously variable over a given range.

Summary of the Invention

The present invention generates sets of sampled data filter weighting coefficients from a single stored set of such coefficients. The weighting coefficients which define the frequency response of a sampled data filter also determine the impulse response of the filter in the time domain. Scaling the frequency response of the filter translates to an inverse scaling of the impulse response, and vice-versa. Therefore, the impulse response may be scaled, i.e., coefficient values at intermediate sample points on the impulse response curve selected, to alter the filter frequency response. In the present invention, scaled coefficient values are determined by piecewise linear interpolation of the set of stored coefficient values, according to the equation

$$H'(I) = a[(H(K+1) - H(K))F_{Ia} + H(K)]$$

where $H'(I)$ are the scaled coefficient values, a is the scaling factor, I is a simple index value, $H(K)$ is the stored coefficient having the index K equal to the integer part of the product (Ia) , $H(K+1)$ is the stored coefficient having the index one greater than $H(K)$, and F_{Ia} is the fractional part of the product (Ia) .



Brief Description of the Drawings

FIGURE 1a is a graphical illustration of the impulse response of an arbitrary sampled data filter and FIGURE 1b is a graphical illustration of the frequency response corresponding to the same arbitrary filter;

FIGURES 2 and 3 are block diagrams of two circuits for developing sampled data filter weighting coefficients from a unique set of stored coefficients; and

FIGURE 4 is a flow chart describing the operational sequence of the FIGURE 3 embodiment.

Detailed Description of the Invention

The time domain and frequency domain functions of a sampled data filter are related by the transform pair given by

$$h(t) \Leftrightarrow H(j\omega) \quad (1)$$

where $h(t)$ is the time domain response of the filter to an input impulse excitation and $H(j\omega)$ is the Fourier transform of $h(t)$.

The width of the frequency response may be scaled by reciprocally scaling the impulse response according to the relationship

$$h(at) \Leftrightarrow \frac{1}{a} H(j\omega/a) \quad a > 0 \quad (2)$$

where "a" is the scale factor. In order that the amplitude of the frequency response be unaffected by scaling, the transform pair of equation (2) is multiplied by the scale factor resulting in the transform pair

$$a h(at) \Leftrightarrow H(j\omega/a) \quad a > 0 \quad (3).$$

Consider a finite impulse response (FIR) filter having a linear phase response. Such a device consists of a tapped delay line with weighting elements coupled to the taps and means for summing the weighted output samples from all of the weighting elements. The weighting coefficients for a linear phase FIR filter are symmetrical about the center tap. The envelope or curve defined by the value of the weighting coefficients describes the time



domain response curve of the filter, i.e., the impulse response.

Figure 1A is the impulse response of a particular low pass FIR filter. Only the portion of the response for time, t , greater than zero is illustrated, but it should be remembered that the curve of the impulse response for $t > 0$ is reflected about the vertical axis at $t=0$. The coefficient magnitude at $t=0$ corresponds to the weighting coefficient at the center tap of the filter.

The sample points on the curve indicate the value of weighting coefficients of successive taps of the filter. For the impulse response illustrated in FIGURE 1, the filter has 15 taps, one corresponding to $t=0$, seven for positive values of t and seven for negative values of t .

The dashed line in FIGURE 1A is the impulse response for the same filter with the coefficients scaled by a factor of 0.8. Note that time is normalized to the delay period between taps.

FIGURE 1B is the corresponding frequency response for the filter having the FIGURE 1A impulse response and the dashed line in FIGURE 1B corresponds to the scaled impulse response of FIGURE 1A.

The tap points on the filter delay line are located at fixed points on the delay line. The delay between taps are at integral multiples of the sample periods of the signal to be filtered. In order to scale the frequency response according to equation (2) or (3), it is necessary to scale time relative to the impulse response curve. However, as stated above, the tap points are fixed and nominally the sample rate is fixed.

Consider the case where it is desired to narrow the bandwidth of the frequency response of the filter. Because of the inverse scaling of the transform pair, this corresponds to broadening the impulse response over time.

For example, if the filter is to be scaled so that the response of the scaled filter at frequency ω is to equal the response of the unscaled filter at ω/a $0 < a < 1$ then the impulse response at time t of the original filter must be translated to the time at in the scaled filter.



Referring to FIGURE 1, scaling the filter by a factor of 0.8 corresponds to shifting the coefficient value at the time 0.8 to the time $t=1$ and the value at $t=1.6$ to the point designated $t=2$. Graphically, the coefficient values at any time (t) can be picked off the curve describing the impulse response. From the curve in FIGURE 1, the coefficient value at $t=0.8$ is approximately 0.153. From equation 3, this value must be multiplied by the scale factor, in this example 0.8, resulting in the scaled coefficient value of 0.1224. This value would be applied to the weighting circuit at the tap corresponding to $t=1$. It is noted that this is not the value at $t=1$ in the scaled curve illustrated by the dashed line. The reason for this is that ultimately the scaled coefficients are normalized so that the sum of all the tap weights equals the value one.

The current invention computes the scaled coefficients by mathematically extrapolating their values by a piecewise linear calculation using the known coefficient values of an unscaled filter. Starting at $t=0$, the scaled coefficient is equal to a $h(0)$. The coefficient at $t=0.8$ is found by finding the approximate slope of the curve between the known points $h(0)$ and $h(1)$, multiplying it by the distance the scaled time is located from the point in time the scaled time is from the lower coefficient value and adding that value to the value for $h(0)$. In other words, the scaled coefficients are calculated according to the equation $y=mx+b$ where y corresponds to the coefficient value, m is the slope, x corresponds to time between the two coefficients corresponding to the scaled time and b is the intercept, that is the value of the lower of the two unscaled coefficients used in the calculation. The slope is determined by the simple equation

$$m = (h(i+1) - h(1)) / (t_{i+1} - t_i).$$

However, the denominator $(t_{i+1} - t_i)$ can be made to drop out of the equation for the slope if the distance between the successive tap points is made unity. Thus, to determine the value of the coefficient at point $t=0.8$, the

coefficient value at $t=0$ is subtracted from the value at $t=1$, the difference is multiplied by 0.8 and the product is added to the coefficient value at $t=0$. Using values from FIGURE 1A

5
$$h(0.8) = 0.8(0.15 - 0.158) + 0.158 = 0.1516$$

which is within about one percent of the value read from the curve. This value is then multiplied by the scale factor to yield the coefficient to be applied to the weighting circuit at tap point $t=1$.

10 FIGURE 2 illustrates circuitry for generating scaled coefficients by the foregoing piecewise linear interpolation method. The particular circuitry shown is arranged to produce coefficients for a linear phase filter wherein the weighting coefficients are symmetrically
15 disposed about the center tap. Thus, for an N tap filter it is only necessary to generate $(N-1)/2$ coefficient values, where N is odd. A slight modification to the circuitry is required for N being even since the number of coefficients required is $N/2$.

20 In FIGURE 2, a storage device 18 which may be a read only memory (ROM) contains one set of filter coefficients chosen to produce a desired filter characteristic within the range of interest. The particular coefficients within the ROM 18 are accessed by
25 means of address signals A applied on bus 16I. The ROM is designed to concurrently output data D at two output ports D_A and D_{A+1} where the data at port D_A corresponds to the information stored in the ROM storage location currently being addressed, and the data at port D_{A+1} corresponds to
30 the information stored in the ROM storage location having an address equal to the current address incremented by one. The filter coefficients $h_0, h_1, h_2, \text{ etc.}$ are stored in sequential address locations 0, 1, 2, etc., respectively.

35 A second storage device 33, which may be a random access memory and supporting addressing circuitry, or a shift register, is included for storing the scaled coefficient values.

The two data output terminals of ROM 18 are coupled to a SUBTRACTOR circuit 22 wherein data from port D_A is subtracted from data at port D_{A+1} . The output of the SUBTRACTOR corresponds to the value $h(i+1) - h(i)$ which approximates the slope, m , of the impulse response between the coefficient values currently addressed.

The output value, " m ", from SUBTRACTOR 22 is applied to one input of a MULTIPLIER circuit 24. A proportionality factor " x " from connection 16F is applied to a second input of the MULTIPLIER circuit 24, the output of which is the product $(m x)$. The product $(m x)$ is applied to one input connection of ADDER circuit 25. The data from the currently addressed storage location in ROM 18 is applied to a second input connection of ADDER 25. Since the interpolation is being performed in a piecewise linear manner between each set of points, i.e., between sets of coefficients $h(i)$ and $h(i+1)$, the leftmost coefficient ($h(i)$) of each pair of coefficients on the impulse response curve represents the " b " intercept for the particular calculation. Therefore, the sum produced by ADDER 25 corresponds to the value $(m x)+b$ or in terms of filter coefficients is $(h(i+1) - h(i))x + h(i)$.

The output value from ADDER 25 is coupled to a first input connection of the MULTIPLIER circuit 26. The scaling factor " a " on bus 27 is applied to a second input connection of MULTIPLIER 26 which produces the product

$$h' = a[(h(i+1) - h(i))x + h(i)] \quad (4)$$

where h' is equivalent to the value of a scaled coefficient.

The scale factor source may be, for example, a keyboard and latch for manually producing a binary number and incrementing and decrementing that number. On the other hand, it may be apparatus which determines the signal-to-noise ratio of the filtered signal and generates a scale factor in accordance with the current signal-to-noise ratio. If the scale factor " a " is an analog variable, then the scale factor source may include an analog-to-digital converter.



Next, we shall consider the proportionality factor "x" and the ROM 18 addressing apparatus. Assume the filter has N taps so that $(N+1)/2$ scaled coefficients are to be generated and assume that the scale factor is 0.2. The scaled coefficients $h(at)$ for $t = 0, 1, 2, 3,$ etc. occur on the impulse response curve corresponding to the stored coefficients in ROM 18 at points corresponding to $t = 0.0, 0.2, 0.4, 0.6,$ etc. The first six scaled coefficient values are located on the unscaled (hereinafter "standard") impulse response between t equal zero and one. For all values of a t between zero and one, the approximate slope of the standard impulse response is determined from the standard coefficients $h(0)$ and $h(1)$, i.e., $m_{0-1} = h(1) - h(0)$. Similarly, for scaled coefficients corresponding between points t equal to one and two on the standard curve, the approximate slope of the curve is determined from coefficients $h(1)$ and $h(2)$. Since the distance between points on the standard impulse response is unity, the value of "x" by which the slope segments are to be multiplied is equal to the fractional part of the product ($a t$).

In FIGURE 2, the ROM 18 addresses, and the "x" values, are generated by a binary COUNTER 12 and a binary MULTIPLIER 15. COUNTER 12 is responsive to a clock signal CL, which may be a square wave, and generates at its output connection 13 a sequence of binary numbers of values 0, 1, 2, 3 ...N+1 after which it resets and commences a new sequence 0, 1, 2, 3...N+1 etc. The binary sequence from the COUNTER is applied to the MULTIPLIER 15. The scale factor "a" is applied to a second input of the MULTIPLIER 15. The output of MULTIPLIER 15 is a binary sequence corresponding to the sequence produced by the COUNTER 12 but multiplied by the scale factor "a". MULTIPLIER 15 is designed with sufficient resolution and range to accommodate the desired resolution and range of the scale factor for the numbers 0 to N+1 produced by the COUNTER. This means that while the COUNTER may only have signal bits to accommodate integer numbers, the MULTIPLIER



has output bit positions for both integer and fractional numbers.

The integer bits 16I of the MULTIPLIER 15 output connection are connected to the address input terminal, of the ROM. Thus, for values of (at) less than one, the address applied to the ROM is the value zero. For $1 \leq$ (at) < 2 , the address applied to ROM 18 is the value one and so one.

The output bits, 16F, corresponding to the fractional part of the product produced by MULTIPLIER 15 represent the value "x" in the sum $(m \times) + b$. Therefore, the fractional bits 16F from multiplier 15 are connected as the "x" input to MULTIPLIER 24.

The circuit described thus far may be operated to continuously calculate sets of scaled coefficients which may be stored directly in the storage element 33 (as indicated by the phantom bus connections 19). However, the scaling factor will generally result in truncation of the scaled impulse response and so it is desirable to normalize the scaled coefficients. For example, if the sum of the standard coefficients was made equal to one because of hardware constraints within the filter, it may be desirable that the sum of the scaled coefficients also equals one. The coefficient normalization is performed by the circuitry circumscribed in the dashed block 50.

In circuit 50, the value of all of the coefficients is accumulated in ACCUMMULATOR 30. After the value of the last scaled coefficient of a set is included in the sum, the total value of the scaled coefficients is dumped into the LATCH 32. As the respective scaled coefficients are input to the ACCUMMULATOR, they are also stored in the SHIFT REGISTER 28 where they are stored in sequence while the sum is being totalized. Each scaled coefficient of the sequence is then shifted out of register 28 and divided by the total sum of the sequence in circuit 31. The normalized scaled coefficients are thereafter stored, for subsequent use, in the storage element 33. In the embodiment shown, it will be noted that the circuitry 50 is clocked



antiphase to the counter. This provides time for propagation of the signal through elements 15, 18, 22, 24, 25 and 26.

It will be remembered that the total number of coefficients is N but only $(N+1)/2$ scaled coefficients were calculated due to the symmetry of coefficient values about the center tap. Thus, in the normalization process, it is necessary to add the value of the scaled coefficients twice or to multiply each coefficient (except the center coefficient) by the factor 2. Binary numbers may be multiplied by 2 simply by shifting their bit positions leftward one bit position. Element 29 between the ACCUMULATOR 30 and MULTIPLIER 26 performs a one bit left shift on the scaled coefficients when the signal at its control input connection 23 is high. Element 29 passes the binary number at its input connection unaltered when the signal on the control input is low. A decoder 14, which may be a conventional OR gate coupled to the output of counter 12, will produce a high output signal for all binary output numbers greater than zero and a low output signal for a binary output number equal to zero. Decoder 14 may therefore be utilized to control the SHIFT LEFT circuit 29 to double all the scaled coefficients except the coefficient corresponding to $h(0)$.

The output of the OR gate 14 is complemented in INVERTOR circuit 35 to reset the accumulator at the beginning of each number sequence and latch the accumulated number therein into the LATCH circuit at the end of each sequence. (Note the end of one sequence corresponds to the beginning of the next.) A delay 34 is interposed between INVERTOR 35 and the reset input terminal (R) of the ACCUMULATOR 30 to insure that the contents therein are transferred to the LATCH 32 before the accumulator is reset to zero.

Referring to FIGURE 3, a microprocessor and support hardware is configured to perform the function of the FIGURE 2 circuit. The microprocessor 62 which may be an RCA Corporation CDP 1802 COSMAC Microprocessor, stimulated by oscillator 61 cycles through program steps

stored in ROM 63. A set of "standard" coefficients which may be stored in ROM 63 or RAM 64 are scaled in accordance with equation 4 with the computed scaled coefficients being stored in RAM 64. The scaling factor is provided to the microprocessor through the input device 60 which for analog scale factors may include an analog-to-digital converter.

FIGURE 4 is a flow chart describing the operation of the FIGURE 3 circuit. When the microprocessor (processing means) is directed to compute scaled coefficients, it is first directed to obtain the scale factor (70) and to initialize an index (I) and sum to zero (71). The index (I) is then multiplied by the scale factor (72). The product (a I) is separated into its integer (K) and fractional parts (a f). Two of the standard coefficients H(K+1), H(K) are accessed from memory. The scaled coefficient H'(I) is then computed according to the equation

$$H'(I) = a[(H(K+1) - H(K))af + H(K)].$$

The scaled coefficient is stored in memory for subsequent normalization. The index I is checked to determine if it is zero. If it is greater than zero, the scaled coefficient is doubled and then summed with the previously calculated scaled coefficients. If the index I is zero, it is placed directly in the accumulator. The index I is then checked to determine if the requisite number of scaled coefficients have been computed. If not, the index I is incremented by one and the foregoing steps reiterated. If the desired number of scaled coefficients have been computed then each of the computed coefficients are divided by the sum of all of the scaled coefficients and successively stored in memory for subsequent application to the filter weighting circuits.

The foregoing embodiments describe apparatus for calculating $(N+1)/2$ scaled weighting coefficients for an N tap filter from $(N+1)/2$ standard coefficients. It will readily be appreciated that by slight modification of the circuitry, N scaled coefficients may be calculated from N

standard coefficients for an N tap filter and thus the invention is applicable for calculating scaled coefficients for filters having other than symmetrical coefficients.



WHAT IS CLAIMED IS:

1. Apparatus for generating scaled weighting coefficients for sampled data filters from a set of N standard weighting coefficients, comprising:

5 means for storing said standard coefficients, wherein said standard coefficients are indexed in a predetermined sequence;

a terminal for applying a scale factor "a";
10 means for generating a sequence of numbers corresponding to the index values of the standard coefficients;

means for generating the products of the scale factor times each of said numbers of said sequence wherein each product has an integer part K and a fractional part
15 F;

means for calculating values for the scaled coefficients according to the equation

$$H'(I) = a[(H(K+1) - H(K))F + H(K)]$$

20 where $H'(I)$ equals a scaled coefficient $H(K)$ is a standard coefficient with index K and $H(K+1)$ is a standard coefficient with index K+1; and

means for storing the scaled coefficients $H'(I)$.

2. The apparatus set forth in Claim 1 further including;

25 means for generating the sum of the scaled coefficients;

means for dividing each of said scaled coefficients by said sum thereby normalizing each scaled coefficient; and

30 means for storing said normalized scaled coefficients for use in a sampled data filter.

3. The apparatus set forth in Claim 1 wherein the means for generating the sequence of numbers is a binary counter responsive to a clocking signal.



4. The apparatus set forth in Claim 1 wherein the means for generating the products of the scale factor times each number is a binary multiplier having parallel output bit lines, respective ones of said output lines corresponding to the integer part of said products and respective ones of said output lines corresponding to the fractional part of said products.

5. The apparatus set forth in Claim 1 wherein the means for storing the standard coefficients is a memory device responsive to the integer part of said products for producing at respective output terminals the standard coefficient having an index value K equal to said integer and the standard coefficient having an index value $K+1$ corresponding to said integer incremented by one.

6. The apparatus set forth in Claim 5 wherein the means for calculating the products $H'(I)$ comprises:

a subtraction circuit having first and second input connections to said memory device for applying the standard coefficients having index values K and $K+1$ and producing at an output connection thereof the difference $(H(K+1) - H(K))$;

a first multiplier circuit having an output connection and having first and second input connections for applying the output from said subtraction circuit, and the fractional value F of the product of the index times the scale factor;

an addition circuit having an output connection, and having first and second input connections for applying signal from the output connection of said first multiplying circuit and from the memory device output terminal producing the standard coefficient $H(K)$; and

a second multiplying circuit having first and second input connections for applying said scale factor and signal from the output connection of said addition circuit, said second multiplying circuit producing at an output terminal thereof, said scaled coefficients.



7. Apparatus for generating sets of scaled weighting coefficients for a sampled data filter from a set of standard coefficients and a scale factor comprising:

means for storing said scaled coefficients, wherein said scaled coefficients are successively indexed, according to their relative position of application in said filter, said standard coefficients being denoted $H(K)$ where K is an index variable;

means for storing said scaled coefficients $H'(I)$ where I is an indexing variable;

a connection for applying a scale factor "A";

processing means preprogrammed to generate a sequence of successive index numbers I , multiplying each number I of said sequence by the scale factor A , accessing the standard coefficients from the means for storing the standard coefficients and the factor A from said connection, calculating the scaled coefficients according to the equation

$$H'(I) = A[(H(K+1) - H(K))F + H(K)]$$

where K equals the integer part of A times I , the product of the scale factor times the number I of the index sequence, and F is the fractional part of the product of A times I , and applying the calculated values $H'(I)$ to the means for storing the scaled coefficients.

8. The apparatus set forth in Claim 7 wherein the processing means is a microprocessor.

9. The apparatus set forth in Claim 8 wherein the means for storing the standard coefficients is a Read Only Memory.

10. The apparatus set forth in Claim 8 wherein the means for storing the scaled coefficients is a Random Access Memory.



11. The apparatus set forth in Claim 7 wherein the processing means is further preprogrammed to normalize the scaled coefficients by summing the values of all the coefficients in a set and dividing each scaled coefficient by the sum of the coefficient value.

12. A method for generating scaled weighting coefficients for application to weighting circuits of a sampled data filter, from a set of standard weighting coefficients predetermined to produce a nominal desired frequency response from said filter, comprising a piecewise linear interpolation of the filter impulse response described by said standard coefficients at points in time corresponding to the relative time position of the standard coefficients multiplied by the scale factor.

13. The method set forth in Claim 11 wherein the standard coefficients $H(K)$ have successive index values K according to their relative positions in the filter and the scaled coefficients $H'(I)$, I being an indexing variable are generated according to the equation

$$H'(I) = A[(H(K+1) - H(K))F + H(K)]$$

where A is a scale factor, F is the fractional part of A times I and K is the integer part of A times I .

14. The method set forth in Claim 11 wherein the interpolation comprises:

storing said standard coefficients H indexed with variables K ;
generating a sequence of variables I ;
multiplying each variable I by the scale factor A ;
determining the integer part K and the fractional part F of the products of A times I ; and
calculating the respective scaled coefficients $H'(I)$ according to the equation

$$H'(I) = A[(H(K+1) - H(K))F + H(K)].$$



Fig. 1a

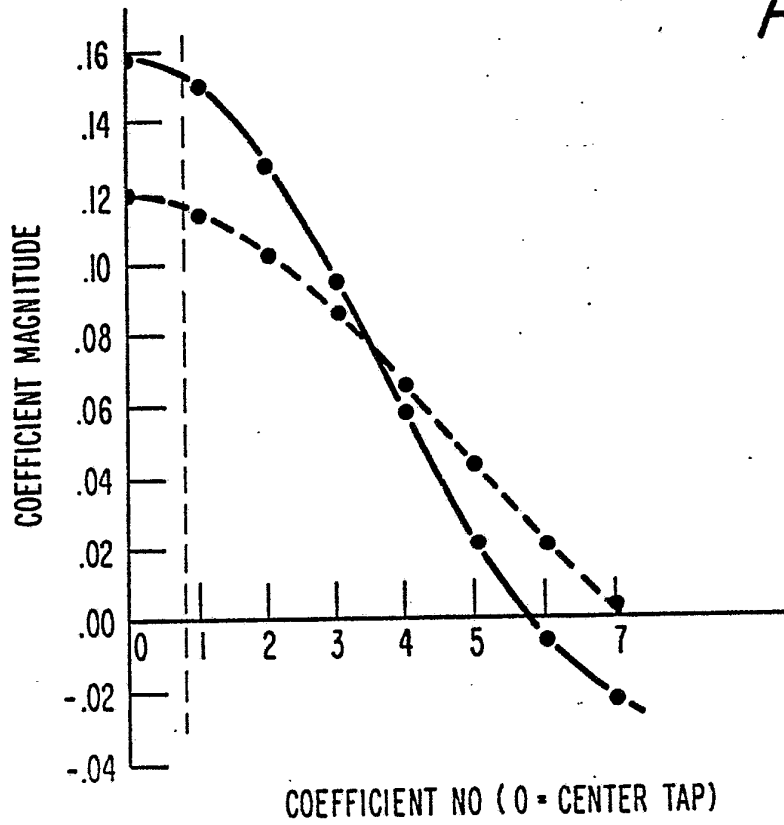
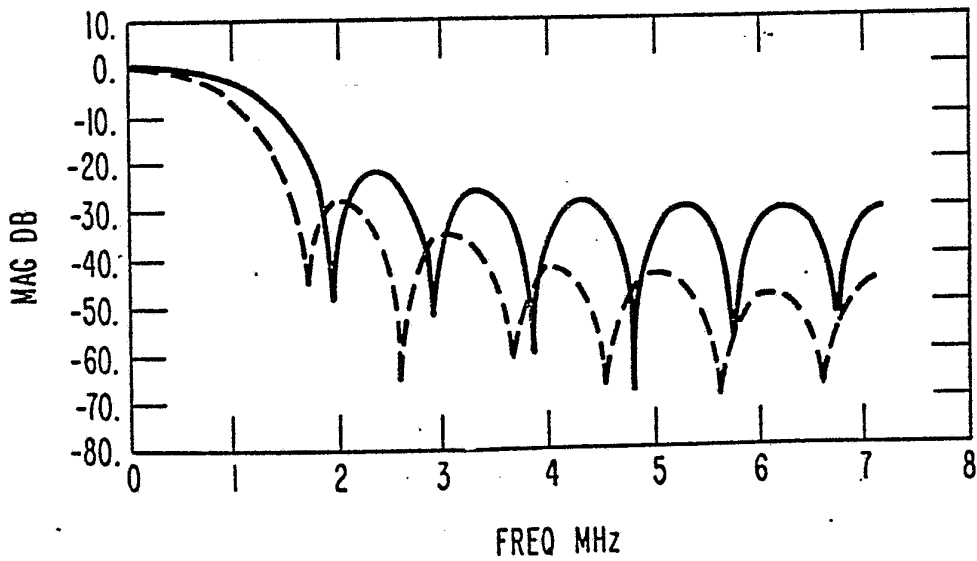

Fig. 1b



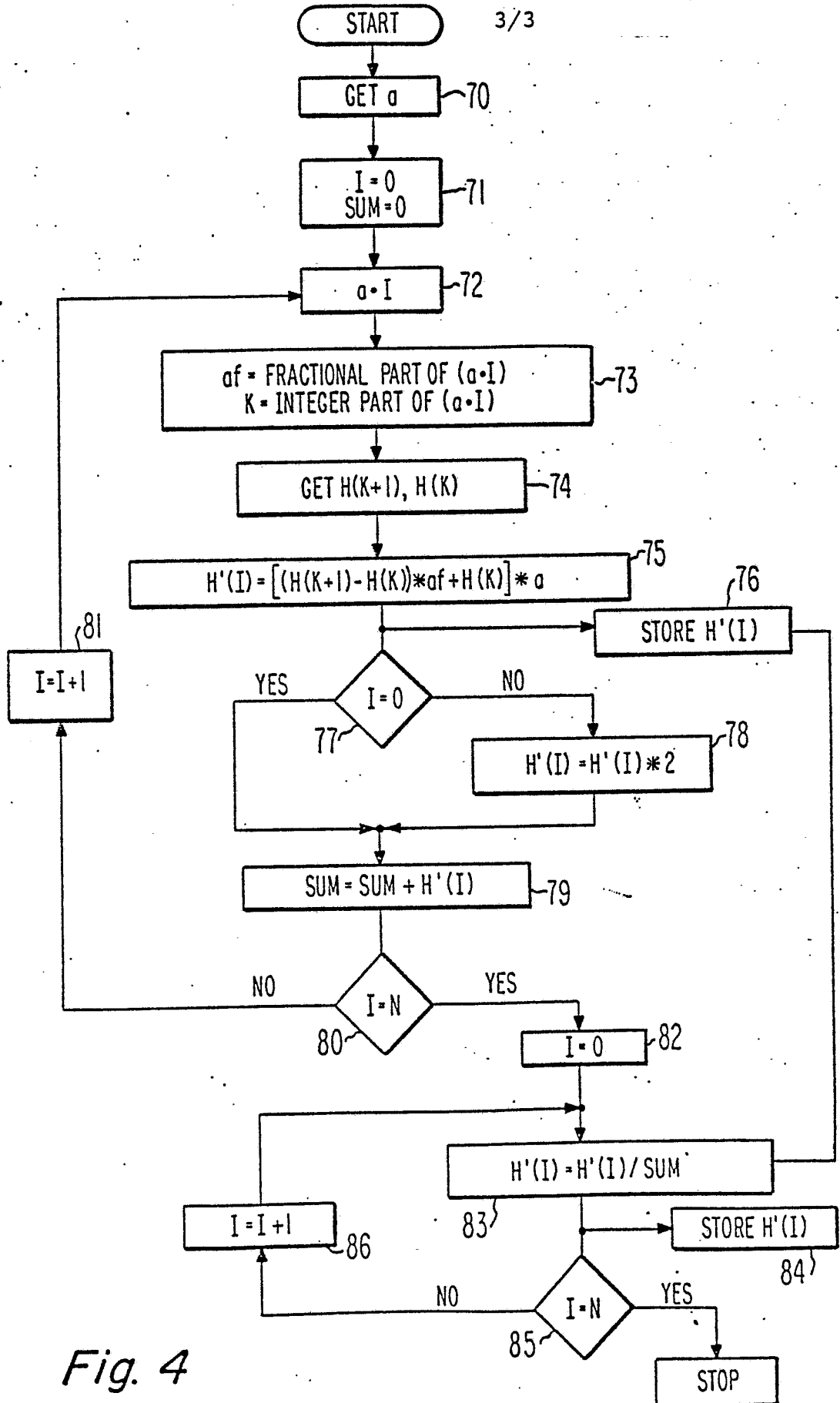
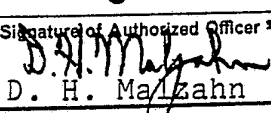

Fig. 4

INTERNATIONAL SEARCH REPORT

International Application No PCT/US84/00141

I. CLASSIFICATION OF SUBJECT MATTER (if several classification symbols apply, indicate all) ³		
According to International Patent Classification (IPC) or to both National Classification and IPC INT. CL. G06F 15/31 U.S. CL. 364/724, ; 333/166		
II. FIELDS SEARCHED		
Minimum Documentation Searched ⁴		
Classification System	Classification Symbols	
U.S.	364/724; 825 333/166	
Documentation Searched other than Minimum Documentation to the Extent that such Documents are Included in the Fields Searched ⁵		
III. DOCUMENTS CONSIDERED TO BE RELEVANT ¹⁴		
Category [*]	Citation of Document, ¹⁶ with indication, where appropriate, of the relevant passages ¹⁷	Relevant to Claim No. ¹⁸
A	U.S., A, 4,125,866 (van Essen et al) 14 November 1978	1-14
A	U.S., A, 4,136,398 (Eggermont) 23 January 1979	1-14
A	U.S., A, 4,145,747 (Sakaki et al) 20 March 1979	1-14
A	U.S., A, 4,366,547 (Miller) 28 December 1982	1-14
A,P	U.S., A, 4,377,793 (Horna) 22 March 1983	1-14
A,E	U.S., A, 4,431,976 (Voorman) 14 February 1984	1-14
A	N, Electronics Letters, Vol. 15 No. 18, issued August 1979, Massey et al, "C.C.D. Adaptive Filter Employing Parallel Coefficient Updating"	1-14
<div style="display: flex; justify-content: space-between;"> <div style="width: 45%;"> <p>[*] Special categories of cited documents: ¹⁵</p> <p>"A" document defining the general state of the art which is not considered to be of particular relevance</p> <p>"E" earlier document but published on or after the international filing date</p> <p>"L" document which may throw doubts on priority claim(s) or which is cited to establish the publication date of another citation or other special reason (as specified)</p> <p>"O" document referring to an oral disclosure, use, exhibition or other means</p> <p>"P" document published prior to the international filing date but later than the priority date claimed</p> </div> <div style="width: 45%;"> <p>"T" later document published after the international filing date or priority date and not in conflict with the application but cited to understand the principle or theory underlying the invention</p> <p>"X" document of particular relevance; the claimed invention cannot be considered novel or cannot be considered to involve an inventive step</p> <p>"Y" document of particular relevance; the claimed invention cannot be considered to involve an inventive step when the document is combined with one or more other such documents, such combination being obvious to a person skilled in the art.</p> <p>"&" document member of the same patent family</p> </div> </div>		
IV. CERTIFICATION		
Date of the Actual Completion of the International Search ²	Date of Mailing of this International Search Report ³	
20 March 1984	30 MAR 1984	
International Searching Authority ¹	Signature of Authorized Officer ¹⁰	
ISA/US	 D. H. Malzahn	

FURTHER INFORMATION CONTINUED FROM THE SECOND SHEET

A	N, Electronics Letters, Vol. 15 No. 20, issued Sept. 1979, Tang et al "Coefficient Correction in Programmable C.C.D. Recursive Filters"	1-14
A	N, Proceedings of the 1981 IEEE International Conference on Acoustic, Speech and Signal Processing 30 March-01 April 1981 Nakayama, "Permuted Difference Coefficient Digital Filters"	1-14

V. OBSERVATIONS WHERE CERTAIN CLAIMS WERE FOUND UNSEARCHABLE ¹⁰

This international search report has not been established in respect of certain claims under Article 17(2) (a) for the following reasons:

1. Claim numbers....., because they relate to subject matter ¹² not required to be searched by this Authority, namely:

2. Claim numbers....., because they relate to parts of the international application that do not comply with the prescribed requirements to such an extent that no meaningful international search can be carried out ¹³, specifically:

VI. OBSERVATIONS WHERE UNITY OF INVENTION IS LACKING ¹¹

This International Searching Authority found multiple inventions in this international application as follows:

1. As all required additional search fees were timely paid by the applicant, this international search report covers all searchable claims of the international application.
2. As only some of the required additional search fees were timely paid by the applicant, this international search report covers only those claims of the international application for which fees were paid, specifically claims:
3. No required additional search fees were timely paid by the applicant. Consequently, this international search report is restricted to the invention first mentioned in the claims; it is covered by claim numbers:
4. As all searchable claims could be searched without effort justifying an additional fee, the International Searching Authority did not invite payment of any additional fee.

Remark on Protest

- The additional search fees were accompanied by applicant's protest.
- No protest accompanied the payment of additional search fees.