



EUROPEAN PATENT APPLICATION

Application number : **94303051.0**

Int. Cl.⁶ : **A47L 9/16, A47L 9/10**

Date of filing : **27.04.94**

Claim 13... is deemed to be abandoned due to non-payment of the claims fee (Rule 31 (2) EPC).

Date of publication of application : **02.11.95 Bulletin 95/44**

Designated Contracting States : **AT BE CH DE DK ES FR GB GR IE IT LI LU MC NL PT SE**

Applicant : **Roberts, Edward John**
33 Heatherside Road,
Ramsbottom
Bury, Lancashire BL10 9BX (GB)

Applicant : **Clixby, Peter William**
Ash House,
Spur Lane,
Myrtle Road
Sheffield S23 HT (GB)

Applicant : **Clixby, Adam William**
Ash House,
Spur Lane,
Myrtle Road
Sheffield S23 HT (GB)

Inventor : **Roberts, Edward John**
33 Heatherside Road,
Ramsbottom
Bury, Lancashire BL10 9BX (GB)
Inventor : **Clixby, Peter William**
Ash House,
Spur Lane,
Myrtle Road
Sheffield S23 HT (GB)
Inventor : **Clixby, Adam William**
Ash House,
Spur Lane,
Myrtle Road
Sheffield S23 HT (GB)

Representative : **Kelvie, George Thomas et al**
Urquhart-Dykes & Lord
The Victoria Suite
3rd Floor
Northern Assurance Buildings
Albert Square
Manchester M2 4DN (GB)

Cyclonic suction cleaner.

A suction cleaner includes a first separation stage in the form of a cyclone (14) from which air descends in an inner helical flow to a debris collection chamber (23), then ascends in an outer helical flow to pass through a filter (28), a ring of blades (30) forming a further separation stage, a second filter (33) and final pleated paper filters (13) arranged around the cyclone. Large solids are separated in chamber (23) by virtue of the change in velocity, protecting filters (13) from impact damage and clogging.

This invention relates to a suction cleaner. The invention is particularly concerned with a suction cleaner of the type described in British patent number GB 2 198 930B, although it is not particularly limited to such a machine.

In industrial suction cleaners which may be used for cleaning in factories, on the streets, or in other comparable environments, a wide range of objects are picked up and have to be stored after separation from the air with which they are entrained. In a cleaner according to the aforesaid patent (and, indeed, in other suction cleaners) the mixture of air and detritus enters a setting chamber wherein air can escape through a filter to atmosphere and entrained detritus falls into a receiving container. Air typically arrives in such a chamber at up to 200ft per second (51m per second). At this velocity articles carried by the air stream can possibly damage the filter. Further, dust particles carried by the air stream can, if they impact the filter, at this speed be driven into or perhaps even through the filter. Whilst being driven completely through the filter to contaminate the atmosphere is rare, particles driven into the filter so as to be almost irremovable by reverse air flow is not uncommon. Additionally, paper particularly small pieces, such as toffee papers can become trapped in the pleats of the filter causing the filter to block after limited use.

The invention provides a suction cleaner provided with means for receiving air and entrained detritus and directing it along an external downward helical path to a container, where particles > 50 microns can be trapped.

The cleaner can be a movable cleaner such as an industrial vacuum cleaner, or can be a fixed apparatus drawing detritus such as wood chips or shavings from a machine or the like.

Desirably the formation is such as to allow the air, after it reaches the bottom of its path to rise in an ascending helical path within the outer helical path. Desirably the air flow is such adjacent the lower end of the two helical paths that at such ends the velocity of the air drops so as to allow entrained particles to drop therefrom into the waste receptacle.

Desirably an upper part of the said means is arranged to direct the flow to an annular lip at which there is a velocity drop causing larger items to drop from the flow.

The annular lip can allow low velocity air to flow upwards towards the filter.

The said means can comprise a cyclone-creating body wherein incoming air enters and is directed by baffles or the like downwardly in a helical manner.

The casing can have an inwardly converging frusto-conical wall, or parallel sides.

The invention will be described further, by way of example, with reference to the accompanying drawings wherein;

Figure 1 is a vertical cross sectional view through

a part of a preferred suction cleaner of the invention ;

Figure 2 is a cross sectional view on line 2-2 of figure 1; and

5 Figure 3 is a vertical cross-sectional view through a part of a further suction cleaner of the invention.

The separator arrangement (10) shown in figure 1 can be disposed in the region of the chamber (32) and container (36) shown in figure 2 of British patent 10 2 198 930B. However, it is also to be appreciated that they can be disposed in any suction cleaner or apparatus of any other design.

Referring to figures 1 and 2, it will be seen that the arrangement (10) has an upper chamber (11) and a lower chamber (12). The upper chamber (11) has an outer wall whose main peripheral portions are constituted by primary filter elements (13). Filter elements (13) are designed to be replaced as little as possible and means can be provided for cleaning them by air flow reversal as described in the aforesaid patent. However, without the provisions of the present invention such filter elements (13) are often impacted by flying particle, and so blocked rapidly by embedment of dust particles and by pieces of paper, and by other waste materials.

In the present invention, however, a cyclone body (14) is provided within but spaced from the filter elements (13). The cyclone body (14) is made from sheet metal and has an inlet (15) along which air flow from a suction head (not shown) is delivered at speeds which may be as high as 51m per second. From the inlet (15) the air flow enters a circular chamber (16) having a closed top (17) within which the air it must circulate. The outer wall of the chamber (16) is wall (18) of the body (14). A circular air flow is caused to develop under pressure from the inlet (15) and is compelled to orbit within the chamber (16). This orbital flow can be enhanced by use of baffles and/or the like. The circular flow is directed downwardly and attains, generally the form of a helix (19).

The outer wall (17) is connected to the upper end of an inverted frusto-conical accelerator wall (20) which has a lower rim (21). Entrained matter travels down the helix (19). Towards the lower end of the waste receptacle (22), which can be a bin liner within a casing (23) and which forms the lower chamber (12), the air in the helix cannot travel further downwards and therefore is caused to travel upwardly making an outer helical path (24) entering the upper chamber (11) through an annulus (25) located between the rim (21) and the casing (23).

As will be apparent from a consideration of the relative sizes of the helices, the distance travelled by the air in the inner helix is far less greater than that by the air in the outer helix and therefore this leads to a very obvious difference in velocity between the two. Thus, the descending air has a high velocity as it is travelling in a smaller helix whilst the ascending

air has a low velocity as it is travelling up a helix of larger diameter. This means that there is a relatively abrupt drop in velocity at the lower end of the helices. This drop in velocity is significant in that it is very helpful in allowing or causing entrained detritus to drop out of the air stream and compact in the bottom of the receptacle (22). Only the smaller dust, particles and pieces of material ascends the outer helix (24).

To prevent the suspended detritus entering the space (26) between the wall (18) and the filters (13) via the annulus (25) two pre-filters are provided. The first pre-filter is an open metal mesh or perforated plate in the form of an inverted channel (28) secured to the rim (16) and a filter support casing (29).

The purpose of the pre-filter is to trap relatively light but relatively large surface area objects, such as pieces of paper.

The second pre-filter is in the form of a filter diffuser comprising a ring of blades (30) set at an angle of 45° inclined towards the direction of air flow (24). The function of the blades (30) is to change the direction of the air flow and thus reduce the velocity of the upwardly directed rotating air flow allowing only particles of < 50 microns to pass to the primary filters (13) for filtration to < 6 microns to atmosphere.

A third pre-filter (33) consisting of a perforated plate can also be provided upstream of the primary filters (13) if required.

The provision of the separating arrangement (10) within the suction cleaner produces a suction cleaner of greatly improved efficiency whose filters are longer lasting and which need cleaning by reverse air flow at longer intervals. Further, as the entrained material is driven down into the second chamber (12) by the air flow there is a better compaction of waste in the bottom of the container and therefore better utilisation of the container volume.

Of course, the arrangement of the invention can be used in suction cleaners of various types and not merely in relation to those of patent 2 198 930B.

The invention is not limited to the precise details of the foregoing and variations can be made thereto. For example, as described the arrangement can have baffles or and the like to encourage helical air flow. Instead of the cyclone body (14) being disposed within and separated from the walls of the filter, the cyclone body could form the wall of the chamber. In this case the accelerator wall (20) could be dispensed with, all air flow taking place via the conduit (18) through an appropriate filter. Even with the cyclone body (14) within the chamber (11) the accelerator wall (20) can be dispensed with if desired.

Of course, the arrangement of the invention is suitable for use not only in mobile or portable suction cleaners, but also in other suction cleaning apparatus, for example static apparatus arranged to extract wood particles/dust from machines or like sources.

Many other variations are possible within the

scope of the invention.

Also, the first mesh type pre-filter (28) can be a cylinder (31) as shown in figure 3, of slightly smaller diameter than the casing (23), sealed at the rim (16) and at its base (32). The cylinder (31) is removed from the casing (23), when the receptacle (22) is taken out for emptying. Also, as the detritus builds up in the receptacle, the space around the rim (21) will be restricted, causing an increase in pressure in the chamber (16). A pressure differential will thus be created between the inside and outside of the chamber (16). The pressure difference can be used to operate an electrical switch to indicate to the operator that the receptacle requires emptying, or to switch the machine off.

Claims

1. A suction cleaner provided with means for receiving air and entrained detritus and directing the air and detritus along an external downward helical path to a container where particles of typically less than 50 microns can be trapped.
2. A suction cleaner as claimed in claim 1 in which the air flow is further directed after it reaches the bottom of its path to rise in an ascending helical path within the external helical path.
3. A suction cleaner as claimed in claim 1 or claim 2 in which the air flow is such adjacent the lower end of the two helical paths that at such ends the velocity of the air drops so as to allow entrained particles to drop therefrom into the container.
4. A suction cleaner as claimed in any one of the preceding claims in which the upper part of the said means is arranged to direct the air flow to an annular lip at which there is a velocity drop causing larger items to fall from the air flow.
5. A suction cleaner as claimed in claim 4 in which the annular lip is arranged to allow low velocity air to flow upwards towards a filter.
6. A suction cleaner as claimed in any one of the preceding claims in which the said means comprises a cyclone-creating body in which incoming air enters and is directed to baffles or the like downwardly in the helical manner.
7. A suction cleaner as claimed in any one of the preceding claims including a casing having an inwardly converging frusto-conical wall or parallel sides.
8. A suction cleaner as claimed in any one of the

preceding claims including a first pre-filter arranged to trap relatively light but relatively large surface area objects.

9. A suction cleaner as claimed in any one of the preceding claims including a second pre-filter arranged to reduce the velocity of the upwardly directed rotating air flow. 5
10. A suction cleaner as claimed in any one of the preceding claims including a third pre-filter comprising a perforated plate or the like. 10
11. A suction cleaner as claimed in any one of the preceding claims including a primary filter to filter out small particles before the air flow is discharged to atmosphere. 15
12. A suction cleaner as claimed in any one of the preceding claims in which the cleaner is a movable cleaner or a fixed apparatus. 20
13. A suction cleaner constructed and arranged for use and operation substantially as herein described and with reference to the accompanying drawings. 25

30

35

40

45

50

55

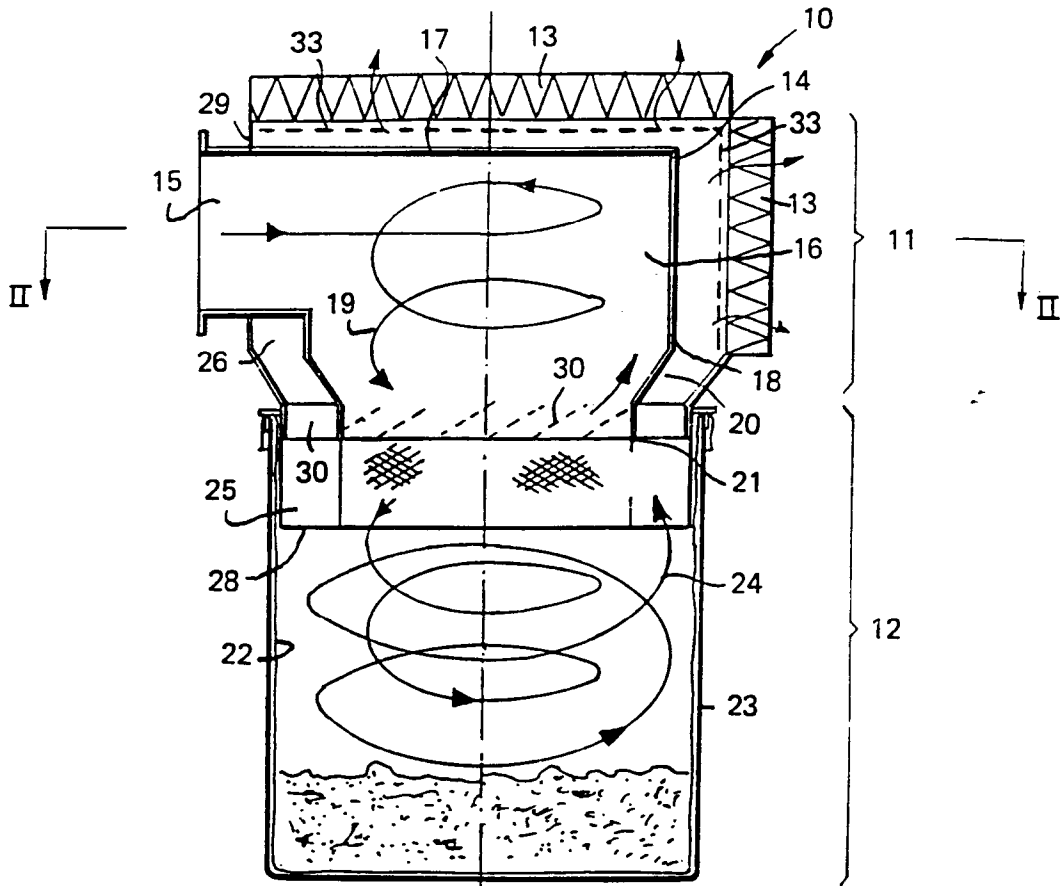

FIG. 1

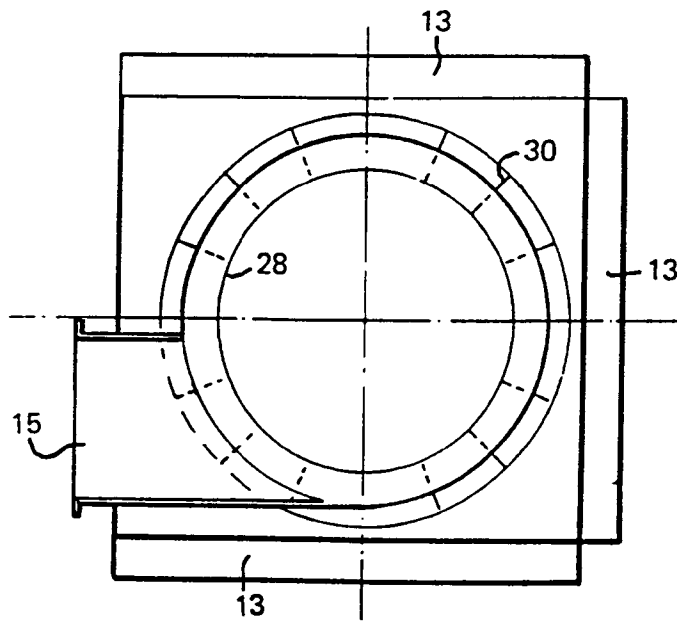

FIG. 2

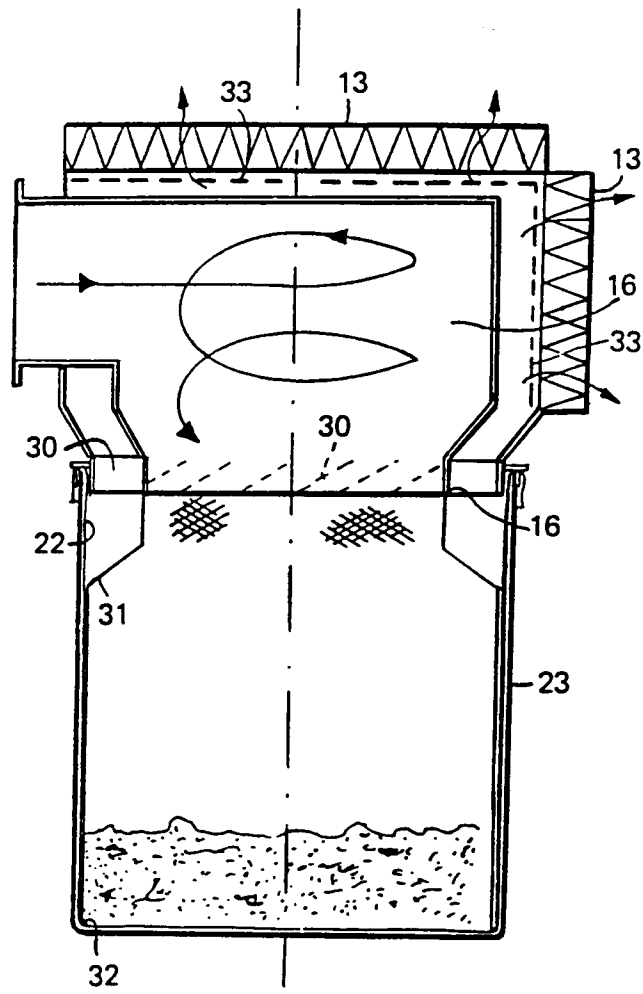

FIG. 3



European Patent
Office

EUROPEAN SEARCH REPORT

Application Number
EP 94 30 3051

DOCUMENTS CONSIDERED TO BE RELEVANT			
Category	Citation of document with indication, where appropriate, of relevant passages	Relevant to claim	CLASSIFICATION OF THE APPLICATION (Int.Cl.6)
X	US-A-2 935 158 (D. BRAUN) * column 2, line 21 - column 3, line 65; figures * ---	1-6,8,9, 12	A47L9/16 A47L9/10
X	FR-A-1 468 142 (SIEMENS-ELECTROGREATE AG) * page 3, line 45 - page 4, line 14; figure 6 * ---	1-3,12	
A	FR-A-2 469 900 (ASPIRATEURS NILFISK SA) * page 2, line 25 - page 7, line 2; figures * ---	1-12	
A	EP-A-0 042 723 (ROTORK APPLIANCES LTD) * the whole document * ---	1-7,12	
A	GB-A-469 539 (THE BRITISH THOMSON-HOUSTON CY LTD) * page 1, line 29 - page 2, line 53; figures 1,2 * ---	6-10	
A	US-A-5 137 554 (N.S. CARTER, JR) * abstract * -----	6,7	TECHNICAL FIELDS SEARCHED (Int.Cl.6) A47L
The present search report has been drawn up for all claims			
Place of search THE HAGUE		Date of completion of the search 30 August 1994	Examiner Vanmol, M
CATEGORY OF CITED DOCUMENTS X : particularly relevant if taken alone Y : particularly relevant if combined with another document of the same category A : technological background O : non-written disclosure P : intermediate document		T : theory or principle underlying the invention E : earlier patent document, but published on, or after the filing date D : document cited in the application L : document cited for other reasons & : member of the same patent family, corresponding document	

EPO FORM 1503 03.82 (P/04C01)