

(12) PATENT
(19) AUSTRALIAN PATENT OFFICE

(11) Application No. AU 199737176 B2
(10) Patent No. 722148

(54) Title
Multiplexed active biologic array

(51)⁷ International Patent Classification(s)
G01N 033/543 G01N 021/75
C12Q 001/68 G01N 027/07

(21) Application No: **199737176**

(22) Application Date: **1997.06.24**

(87) WIPO No: **WO98/01758**

(30) Priority Data

(31) Number	(32) Date	(33) Country
08/677305	1996.07.09	US

(43) Publication Date : **1998.02.02**

(43) Publication Journal Date : **1998.03.26**

(44) Accepted Journal Date : **2000.07.20**

(71) Applicant(s)
Nanogen, Inc.

(72) Inventor(s)
Gregory T. A. Kovacs

(74) Agent/Attorney
SPRUSON and FERGUSON,GPO Box 3898,SYDNEY NSW 2001

(56) Related Art
WO 93/22678
SENSORS AND ACTUATORS B, 34 (1996), 450-455
SENSORS AND ACTUATORS B, 18-19 (1994), 675-677

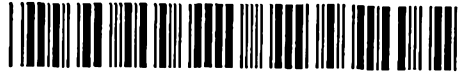

(51) International Patent Classification ⁶ :
G01N 33/543, 27/07, 21/75, C12Q 1/68 A1
(11) International Publication Number: **WO 98/01758**
(43) International Publication Date: **15 January 1998 (15.01.98)**

(21) International Application Number: **PCT/US97/10997**
(22) International Filing Date: **24 June 1997 (24.06.97)**

(30) Priority Data:
08/677,305 **9 July 1996 (09.07.96)** **US**

(71) Applicant: **NANOGEN, INC. [US/US]; 10398 Pacific Center Court, San Diego, CA 92121 (US).**

(72) Inventor: **KOVACS, Gregory, T., A.; 105 Peter Courtts Circle, Stanford, CA 94305 (US).**

(74) Agents: **BROGAN, James, P. et al.; Lyon & Lyon LLP, Suite 4700, 633 West Fifth Street, Los Angeles, CA 90071-2066 (US).**

(81) Designated States: **AU, BR, CA, CN, JP, KR, NZ, European patent (AT, BE, CH, DE, DK, ES, FI, FR, GB, GR, IE, IT, LU, MC, NL, PT, SE).**

Published
With international search report.

(54) Title: **MULTIPLEXED ACTIVE BIOLOGIC ARRAY**

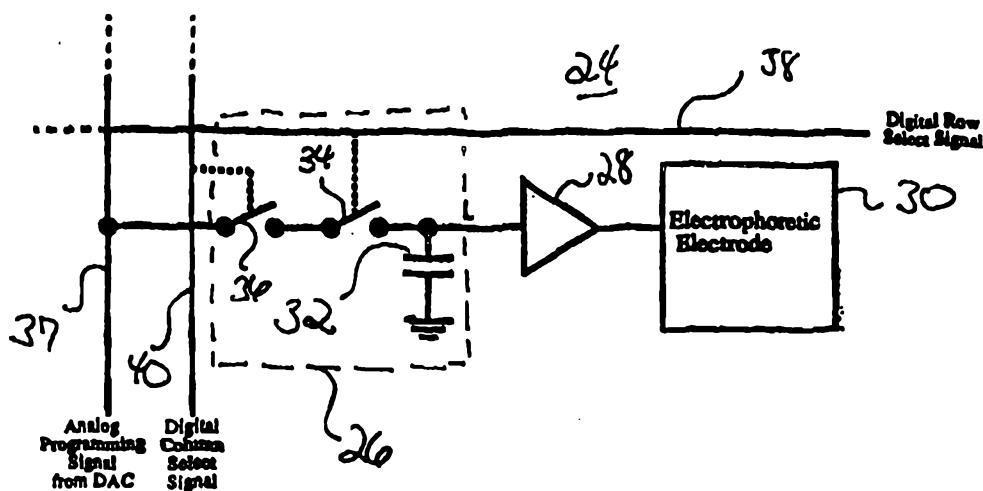

(57) Abstract

An improved biologic electrode array (12) and methods for using the same. Each electrode (30) in the array (12) is coupled to a respective sample-and-hold circuit (26). The electrodes (30) and sample-and-hold circuits (26) are integral and form an array (12) within a single semiconductor chip, such that each sample-and-hold circuit (26) may be loaded (37) with a predefined voltage provided by a single, time-shared digital-to-analog converter (DAC) (22). All of the sample-and-hold circuits (26) may be accessed through a multiplexer which may scan through some or all of the electrode locations (30). Each sample-and-hold circuit (26) may comprise a capacitor (32) and one or more transistor switches (34, 36), the switches (34, 36), when closed providing electrical communication between the capacitor (32) and a source line (37) formed in the matrix (12).

DESCRIPTION

Multiplexed Active Biologic Array

Field of the Invention

The present invention relates generally to electronic systems for carrying out and/or monitoring biologic reactions and, more particularly, to the design, fabrication and uses of self-addressable, self-assembling microelectronic systems for carrying out and controlling multi-step and multiplex reactions in microscopic formats.

Background of the Invention

For some time now, substantial attention has been directed to the design, implementation and use of array-based electronic systems for carrying out and/or monitoring biologic reactions.

For example, it has been recognized that electronic biosensors of various types may be used to monitor (or measure) the progress of certain biologic reactions, and that arrays of these sensors may be fabricated using techniques similar to those utilized in the integrated circuits field.

As shown in Fig. 1, a typical prior art biosensor 1 may include a biospecific immobilization surface 2 having an immobilized affinity ligand 3 bound thereto, a transducer 4 capable of sensing the occurrence of chemical reactions which may occur between the immobilized ligand 3 and a specific analyte, and an amplification and control unit 5 for filtering, amplifying and translating signals generated by the transducer 4 into various measurements useful for monitoring the progress or occurrence of a selected biologic reaction. Biosensors of the type described above are discussed in some detail in Protein Immobilization, Fundamentals & Applications, R.F. Taylor, ed. (1991) (chapter 8); and Immobilized Affinity Ligand Techniques, Hermanson et al. (1992) (chapter 5).

The fabrication of an array of biosensors is disclosed, for example, in U.S. Patent Application Serial No. 07/872,582, entitled "Optical and Electrical Methods and Apparatus for Molecule Detection" (published November 5 14, 1993 as International Publication No. WO93/22678, and hereinafter referred to as "the Hollis et al. application"). The Hollis et al. application is directed primarily to biosensory devices comprising an array of test sites which may be electronically addressed using a plurality of conductive leads. Various types of biosensors are described for use at the test sites, and it is suggested that the test sites may be formed in a semiconductor wafer using photolithographic processing techniques. It is further suggested that the test sites may be coupled 10 to associated detection circuitry via transistor switches using row and column addressing techniques employed, for example, in addressing dynamic random access memory (DRAM) or active matrix liquid crystal display (AMLCD) devices. 15

In addition to the biosensor devices described above, 20 several devices capable of delivering an electrical stimulus (or signal) to a selected location (or test site) within a solution or elsewhere, have been developed. As shown in Fig. 2, these devices often include a source 6, such as a current, voltage or power source, an electrode 25 7 coupled to the current source 6, a permeation layer 8 formed on one surface of the electrode 7, and a biologic attachment layer 9 formed upon the permeation layer 8. The permeation layer 8 provides for free transport of small counter-ions between the electrode 7 and a solution 30 (not shown), and the attachment layer 9 provides for coupling of specific binding entities.

Exemplary systems of the type described above are disclosed in PCT Application No. PCT/US94/12270, which was published in May 1995, and is entitled "Self-Addressable 35 Self-Assembling Microelectronic Systems and Devices for Molecular Biological Analysis and Diagnostics," and PCT Application No. PCT/US95/08570, which was published on

January 26, 1996, and is entitled "Self-Addressable Self-Assembling Microelectronic Systems and Devices for Molecular Biological Application," (hereinafter "the Heller et al. applications") both of which are hereby
5 incorporated by reference. The Heller et al. applications describe electronic devices which may be fabricated using microlithographic or micromachining techniques, and preferably include a matrix of addressable micro-locations on a surface thereof. Further, individual micro-locations
10 are configured to electronically control and direct the transport and attachment of specific binding entities (e.g., nucleic acids, anti-bodies, etc.) to itself. Thus, the disclosed devices have the ability to actively carry out controlled multi-step and multiplex reactions in micro-
15 scopic formats. Applicable reactions include, for example, nucleic acid hybridizations, anti-body/antigen reactions, clinical diagnostics, and multi-step combinational biopolymer synthesis reactions.

Additional electronic systems for interfacing with
20 various solutions and/or biologic entities are disclosed in European Patent Application No. 89-3133379.3, published April 7, 1990 and entitled "Electrophoretic System;" U.S. Patent No. 5,378,343, issued January 3, 1995 and entitled "Electrode Assembly Including Iridium Based Mercury Ultra-
25 microelectrode Array;" U.S. Patent No. 5,314,495, issued May 24, 1995 and entitled "Microelectronic Interface;" and U.S. Patent No. 5,178,161, issued January 12, 1993 and entitled "Microelectronic Interface."

Those skilled in the art will appreciate, however,
30 that conventional electronic systems for carrying out and/or monitoring biologic reactions (including the devices described in the above-referenced patents and patent applications) are often bulky, expensive and, at times, difficult to control. Moreover, those skilled in
35 the art will appreciate that, because conventional biologic systems often utilize "off-chip" circuitry to generate and control the current/voltage signals which are

applied to an array of test sites, it is often difficult without the use of special equipment to precisely control the current/voltage signals generated at particular test sites. As for those conventional systems which do employ "on-chip" circuitry to generate and control the current/voltage signals which are applied to an array of test sites, in certain cases substantial difficulties have been encountered where it is desired to provide separate and distinct stimuli to selected electrode sites within a large array. One reason for this is that, when single site stimulus specificity is desired within conventional biosensor arrays, that need is often satisfied through the provision of independent signal lines for each electrode site within the array. As a result, conventional biologic systems are often more cumbersome and expensive than is desirable.

In view of the above-noted limitations of conventional biologic systems, it is submitted that an improved biologic system which utilizes a minimum of "off-chip" circuitry and enables the use of large arrays of electrode sites while providing for very precise control of the voltages/currents delivered at a given electrode site, would be both useful and desirable.

Summary of the Invention

The present invention is directed to the design, implementation and use of improved electronic systems and devices for carrying out and/or monitoring biologic reactions.

In one innovative aspect, a biologic electrode array in accordance with the present invention may comprise a matrix of electrode sites, wherein each electrode site comprises an electrode which is coupled to a respective sample-and-hold circuit via an amplifier circuit (or driving element). In a preferred form, the electrodes, amplifiers and sample-and-hold circuits are integral and form an array within a single semiconductor chip, such

that each sample-and-hold circuit may be loaded with a predefined voltage provided by a single, time-shared digital-to-analog converter (DAC). Further, all of the sample-and-hold circuits may be accessed through a multi-plexer which may be scanned through some or all of the electrode locations. In this embodiment, each sample-and-hold circuit may comprise a capacitor and a transistor switching circuit, the transistor switching circuit, when enabled, providing electrical communication between the capacitor and a source line formed in the matrix. However, in alternative embodiments, the sample-and-hold circuits may comprise some other type of memory which may be addressed and loaded with a signal (or value) indicative of a characteristic of an electrical stimulus to be applied at an associated electrode. Such alternative memories may include electrically erasable programmable read only memory (EEPROM) cells used as an analog memory (e.g., as in the non-volatile analog signal storage chips produced by Information Storage Devices, Inc., of San Jose, California), or other types of circuits capable of storing control information and producing proportional analog output values.

In another innovative aspect, a biologic electrode array in accordance with the present invention may comprise a single semiconductor chip having formed thereon a memory (for example, a random access memory (RAM)), a digital-to-analog converter (DAC) coupled to the memory, a counter, a row decoder coupled to the counter and to the memory, a column decoder coupled to the counter and to the memory, and a matrix of active biologic electrode sites coupled to the row decoder and the column decoder. In use, binary values representing voltages to be applied at the various electrode sites within the array are stored in the memory using, for example, an external computer. Then, for each address (or a selected number of addresses) within the array a binary value is read out of the memory and provided to the DAC which, in turn, converts the

binary value to a voltage to be stored on the "hold" capacitor at a selected address. Once all of the addresses of the array (or the selected number of addresses) have been scanned in this fashion, the process
5 may be repeated using either the same values initially stored in the memory or new values depending upon whether or not time variation of the voltages/currents provided at the various electrode sites is desired. Those skilled in the art will appreciate that the scanning process should
10 be repeated often enough such that the decay over time of the stored voltages on the sample-and-hold circuits (due to unavoidable leakage currents) does not result in an unacceptable voltage/current errors at the electrodes. If non-volatile sample-and-hold circuits are used (i.e., if
15 EEPROM or some equivalent technology is utilized), such decays may not be significant, allowing for arbitrarily slow update rates.

In an alternative embodiment, the memory, counter and DAC may be disposed on one or more separate chips.

20 In view of the foregoing, it will be appreciated that a biologic array in accordance with the present invention provides for very precise control of the potentials/currents delivered to individual electrodes within the array, while minimizing the utilization of "off-chip"
25 circuitry and overall system costs. Further, by using local sample-and-hold circuits (or other local memory circuits) to control the level of electrical stimulus applied to particular test sites, arrays in accordance with the present invention may achieve a level of stimulus
30 specificity and electrode utilization far superior to that achieved using most prior art systems.

In another innovative aspect, the present invention provides for the fabrication of an entire active array surface on a thermally-isolated membrane containing on-
35 board, controllable heating elements. By cycling the temperature of the heating elements, it is possible to

perform DNA amplification *in situ*, for example, by the polymerase chain reaction.

Finally, in still another innovative aspect, the present invention provides for the incorporation of optical fluorescence or absorption detection circuitry within a biologic electrode array matrix to improve coupling of emitted photons into the detection electronics. More specifically, in accordance with one embodiment of the present invention, a biologically active electrode is formed above a suitable optical detector such as a MOS-photodiode structure within, for example, a CMOS circuit. In such an embodiment, the electrode may be formed from a substance which is at least partially transparent, or the electrode may be formed in such a fashion that it permits the passage of light through its body to an underlying photodetector.

In view of the foregoing, it is an object of the present invention to provide an improved biologic electrode array for carrying out and controlling multi-step and multiplex reactions in microscopic formats.

It is another object of the present invention to provide an improved biologic electrode array which is compact and minimizes the utilization of off-chip control circuitry, even for large numbers of electrodes.

It is another object of the present invention to provide an improved biologic electrode site which includes a sample-and-hold circuit, and which may be fabricated using conventional CMOS semiconductor fabrication techniques.

It is still another object of the present invention to provide an improved biologic electrode array which includes heating elements for enhancing the progression of reactions such as DNA amplification *in situ*.

It is still another object of the present invention to provide an improved biologic array which includes a plurality of optical detectors formed beneath selected electrode sites.

Brief Description of the Drawings

Fig. 1 is an illustration of a prior art passive biologic system.

Fig. 2 is an illustration of a prior art active
5 biologic system.

Fig. 3 is an illustration of a biologic array in accordance with one form of the present invention.

Fig. 4(a) is an illustration of a biologic electrode site in accordance with one form of the present invention.

10 Fig. 4(b) is a circuit diagram showing in more detail one of the switching circuits and the amplifier circuit of the biologic electrode site illustrated in Fig. 4(a).

Fig. 4(c) illustrates how those portions of the electrode site illustrated in Fig. 4(b) might be
15 fabricated using CMOS circuitry.

Fig. 5 is an illustration of a biologic electrode site which includes circuitry for monitoring an electrical characteristic of an electrode located at the site.

Fig. 6(a) illustrates the fabrication of a combined
20 thermally isolated membrane and biologic electrode array, wherein the biologic electrode array is etched onto a back side surface of a silicon substrate.

Fig. 6(b) illustrates the attachment of a low-thermal-conductivity chamber to the combined thermally
25 isolated membrane and biologic electrode array shown in Fig. 6(a).

Fig. 7 illustrates a biologic electrode site including an optical detector in accordance with the present invention.

30 Fig. 8(a) is a top view of a punctuated, partially transparent electrode in accordance with one form of the present invention.

Fig. 8(b) is a top view of an alternative embodiment of a partially transparent electrode in accordance with
35 the present invention.

Detailed Description of Preferred Embodiments

Turning now to the drawings, as shown in Fig. 3, a biologic array 10 in accordance with one preferred form of the present invention may comprise a matrix of active biologic electrode sites 12, a row decoder 14, a column decoder 16, a counter 18, a random access memory (RAM) 20 acting as a look-up table, and a digital-to-analog converter (DAC) 22. In a preferred form, each of the above listed elements may be disposed on a single semiconductor chip, and the entire array 10 may be fabricated using conventional CMOS semiconductor fabrication techniques. Further, in the presently preferred form a computer (not shown) may be used to load data, as needed, into the RAM 20 via, for example, a data input port 21.

Turning now also to Fig. 4(a), each biologic electrode site 24, which makes up the matrix of biologic electrodes 12, may comprise a sample-and-hold circuit 26, an amplifier 28 and an electrode 30. In one preferred form, the sample-and-hold circuit 26 may comprise a capacitor 32 and two transistor switches 34 and 36. The switches 34 and 36 are connected in series and, when closed, provide electrical communication between a voltage source line 37 (coupled to the DAC 22) and the capacitor 32. The switches 34 and 36 are coupled, respectively, to a designated row select line 38 and column select line 40 formed within the matrix 12.

As shown in Figs. 4(b) and 4(c), each row select line 38 and each column select line 40 may comprise, for example, a positive control line (+ control line) 41 and a negative control line (- control line) 43, and each switch 34 or 36 may comprise a CMOS transmission gate, i.e., a PMOS FET 45 having a gate region 47 coupled to the negative control line 43 and a NMOS FET 49 having a gate region 51 coupled to the positive control line 41. In addition, the amplifier circuit (or driving element) 28 may comprise a PMOS current source 53.

In an alternative embodiment, a single switch, such as that described above, may be controlled by a two input logic gate (e.g., an AND or NAND gate) with complementary outputs (e.g., a + control line and - control line), and
5 may be used to selectively connect the capacitor 32 to the voltage source line 37. In such an embodiment, the logic gate would respond to a coincidence of signals on the row and column select lines 38 and 40, respectively. Further, it may be noted that in some instances a two transistor
10 transmission gate will not be needed, and a single MOS transistor can be used as a switch. In such a case, the logic gate need only provide a single output to the switch.

The design, fabrication and function of counters, row
15 decoders, column decoders, digital-to-analog converters, and random access memories are well known in the art and, thus, the structure and operation of those elements are not discussed in detail herein. Rather, a general description of the function of the biologic electrode
20 array 10 is provided below.

In use, binary values representing voltages to be applied at the various electrode sites 24 within the matrix 12 are stored in the RAM 20 (or other suitable memory device) using, for example, an external computer.
25 Then, for each address (or a selected number of addresses) within the matrix 12 a binary value is read out of the RAM 20 and provided to the DAC 22 which, in turn, converts the binary value to a voltage to be stored on the capacitor 32 located at the selected site address. An output amplifier
30 28 is coupled between the capacitor 32 and the electrode 30 and provides an amplified stimulus signal to the electrode 30. The output amplifier 28 may comprise a voltage amplifier and/or buffer and may thus amplify the voltage on the capacitor 32 and provide an amplified voltage to
35 the electrode 30. Alternatively, the output amplifier 28 may comprise a current output amplifier (for example, a transconductance amplifier) and provide a current signal

to the electrode 30. Once all of the addresses of the matrix (or the selected number of addresses) have been scanned in this fashion, the process may be repeated using either the same values initially stored in the RAM 20 or
5 new values, depending upon whether or not time variation of the voltages/ currents provided at the various electrode sites is desired. Those skilled in the art will appreciate that the scanning process should be repeated often enough such that the decay over time of the stored
10 voltages on the capacitors 32 (due to unavoidable leakage currents) does not result in an unacceptable voltage/ current error at the electrodes 30.

In equivalent and alternative forms, the counter 18, RAM 20, and DAC 22 may be placed on or off of the chip
15 comprising the electrophoretic electrode array, as a matter of design choice, and if desired, some other type of circuit (for example, a simple counter or shift register) may be used to control the sequential loading of the sample-and-hold circuits 26 located at the respective
20 electrode sites 24.

Turning now also to Fig. 5, for some applications it may be desirable to provide for monitoring of the condition (or electrical characteristics) of one or more of the electrodes 30 within the matrix 12. In this case, it is
25 assumed that if the electrode is driven with a known current, the voltage that develops is sensed, or, if the electrode is driven with a known voltage, the current that flows is sensed. To allow monitoring of the condition of a given electrode 30 a voltage sense amplifier 42 may be
30 coupled to the electrode 30 and to a secondary multiplexing bus or output pin (not shown). The voltage sense amplifier 42 provides an indication of the voltage at the electrode 30 relative to an electrical ground (not shown) for the entire array or relative to a selected reference
35 electrode (not shown) on the array. The voltage of the reference electrode may, in some instances, also be the ground used for the array. It should be noted that the

output of the sense amplifiers 42 for the electrode sites 24 in the array may also be multiplexed onto a common sense signal line, and that the signals provided to the common sense signal line may be de-multiplexed using conventional circuitry, such as a sample-and-hold circuit (not shown) and an analog-to-digital converter (not shown). The common sense signal line may be separate from the common signal line (i.e., the voltage source line 37), or it may be same line, in which case, it would be time shared, serving for some selected periods of time to provide charging signals to the capacitors 32 of the electrode sites 24, and serving for other periods of time as a carrier for sense signals generated at the electrode sites 24.

In the case where the electrodes 30 are driven by voltage amplifiers 28 and the current that flows through the electrode 30 is to be sensed, a sense resistor (not shown) may be connected between the output of the voltage amplifier 28 and the electrode 30, and two inputs of a differential amplifier circuit (not shown) may be connected across the sense resistor. In such an embodiment, the signal generated at the output of the differential amplifier will be proportional to the current flowing through the electrode 30.

As explained to some extent above, while the embodiments illustrated in Figs. 4(a) and 5 employ two switches 34 and 36 connected in series to control the loading of the capacitor 32 (one switch being controlled by each of the row and column lines, respectively) those skilled in the art will appreciate that the switching function may be implemented in any of a number of ways. For example, it would be considered equivalent to replace the switches 34 and 36, shown in Figs. 4(a) and 5, with CMOS transmission gates or a combination of an AND gate and a switch.

Turning again to Fig. 4(c), in a preferred form the biologic array 10 may be fabricated using a CMOS or other

active circuit process. Moreover, those skilled in the art will appreciate that completely fabricated CMOS circuitry embodying some or all of the above-described functions may be post-processed to form the complete
5 active biologic electrode array 10 described above. For example, as illustrated in Fig. 6, the biologic electrodes 30 may be disposed atop the underlying CMOS circuitry and then protected with an overlapping passivation layer 44. Further, openings in the passivation layer 44 may be
10 fabricated to expose the active regions of the biologic electrodes 30 as well as any required peripheral inter-connection sites, e.g., bond-pads (not shown). In such an embodiment, the electrodes 30 may be fabricated from electrochemically suitable materials, such as gold, iridium or
15 platinum, and may be deposited and patterned using conventional thin-film deposition techniques. The passivation layer 44 may comprise, for example, plasma-deposited silicon nitride and/or silicon carbide, and openings in the passivation layer 44 may be formed using conventional
20 microfabrication techniques such as plasma etching. Finally, if biomolecules are to be bound on or near the surface of the electrodes 30, coupling agents and/or intermediate layers (shown in Fig. 7) may be used.

Turning now to Figs. 6(a) and 6(b), in another preferred form the entire active surface of the biologic
25 array 10 may be formed on a thermally-isolated membrane 46 containing one or more on-board, controllable heating elements (not shown). The thermally-isolated membrane can be formed using micromachining techniques well-known in
30 the art. For example, the back-side of the completed CMOS waver containing the biologic array circuitry and electrodes can be coated with a suitable etch mask (e.g., silicon nitride). The silicon nitride is patterned using standard techniques to form openings where the membrane is
35 to be formed. The membranes are formed by submerging the wafer in an etching solution (e.g., tetramethylammonium hydroxide loaded with dissolved silicon, as described in

Klassen, et al., "Micromachined Thermally Isolated Circuits," Proceedings of the Solid-State Sensor and Actuator Workshop, Hilton Head, South Carolina, June 3-6, 1996, pp. 127-131). The membrane can thus be temperature
5 cycled to allow DNA amplification *in situ*. Further, controllable heating of the membrane may be accomplished through the use of an array of resistors or appropriately biased MOSFETS (metal oxide semiconductor field effect transistors) distributed throughout the membrane area.
10 Thus, if a solution 48 (shown in Fig. 7(b)) overlying the array 10 is provided with DNA and suitable chemicals to carry out a polymerase chain reaction (PCR) to amplify the DNA, cycling the temperature of the membrane will allow the desired amplification. If thermal feedback is
15 desired, the temperature of the membrane may be readily determined. For example, the temperature coefficient of resistance of the heater resistors or the forward voltage of diodes incorporated into the membrane may be utilized to provide an indication of the solution temperature.
20 Finally, once the DNA contained within the solution 48 is amplified, appropriate chemicals may be injected into the chamber 50 to effect one or more desired analysis steps. Examples of such chemicals are restriction enzymes, fluorescent labels and intercalators, etc.

25 An exemplary micromachined, membrane-based DNA amplification system has been demonstrated by Northrup, et al. (see Northrup et al., "DNA Amplification with a Microfabricated Reaction Chamber," Proceedings of Transducers '93, the 7th International Conference on Solid
30 State Sensors and Actuators, Yokohama, Japan, June 7-10, 1993, pp. 924-926, which is incorporated herein by reference) and, thus, the specific structure and operation of the membrane-based DNA amplification system is not discussed herein in detail. However, it should be noted that
35 the Northrup et al. system provides merely for thermal cycling, and has no analysis or biologic electrode control capabilities. Thus, it is believed that those skilled in

the art will find a biologic array in accordance with present invention to be highly advantageous, as such an array allows for *in situ* DNA amplification and subsequent analysis using a single device.

5 Turning now to Fig. 7, for some applications, it may be desirable to incorporate optical fluorescence or transmittance detection circuitry directly into the electrode matrix 12 to improve coupling of emitted or transmitted photons into any provided detection electronics. In the
10 case of fluorescence detection, the entire array would be illuminated with light at wavelength(s) known to excite fluorescence in the fluorescently labeled biomolecules such as DNA or intercalators between DNA strands. This light would be detected by the optical detection means
15 located at each site. In the case of transmittance detection, the entire array would be illuminated with light at wavelength(s) known to be attenuated by the presence of the biomolecules of interest (i.e., the light at those wavelengths is absorbed by the biomolecules). The
20 presence of the biomolecules of interest at a given electrode site would be detected by an attenuation of the light sensed by the optical detector local to that site. This approach can greatly improve the signal-to-noise ratio (SNR) over the use of an imaging camera remote to
25 the biologic array 10. In essence, this involves combining a biologically active electrode (with or without active multiplexing circuitry) above a suitable optical detector 50 such as a MOS-photodiode or a charge-coupled device (CCD) structure. In such an embodiment, it may be
30 desirable to utilize transparent electrodes, such as those formed from indium tin oxide (ITO), or it may be desirable to utilize a slitted or punctuated electrode structure, such as that shown in Figs. 8(a) and 8(b). By providing
35 orifices 54 (as shown in Fig. 8(a)) or troughs 56 (shown in Fig. 8(b)) through the surface of the electrode 52 it is possible to allow the passage of light through the electrode 52 to the optical detector 50. Those skilled in

the art will appreciate that by eliminating the need for an external camera and retaining the ability to perform biologically-controlled hybridizations (or other molecular interactions), the overall cost of a complete analysis system can be greatly reduced.

While the invention of the subject application may take several alternative and equivalent forms, specific examples thereof have been shown in the drawings and are herein described in detail. It should be understood, however, that the invention is not to be limited to the particular forms or methods disclosed, but to the contrary, the invention is to cover all modifications, equivalents, and alternatives falling within the spirit and scope of the appended claims.

Claims

1. A biologic electrode matrix, comprising:
a plurality of addressable biologic electrode sites,
wherein each electrode site comprises an electrode, an
5 output amplifier circuit having an output coupled to said
electrode, a capacitor coupled to an input said output
amplifier circuit, and at least one switch coupled to said
capacitor.

2. The biologic electrode matrix of claim 1,
10 wherein each biologic electrode site further comprises a
voltage amplifier having an input coupled to said
electrode for sensing a voltage of said electrode.

3. The biologic electrode matrix of claim 1,
wherein each biologic electrode site further comprises a
15 current sensing circuit having an input coupled to said
electrode for sensing a current flowing through said
electrode.

4. The biologic electrode matrix of claim 1,
wherein
20 said plurality of biologic electrode sites are
arranged in a plurality of rows and columns,
each row of biologic electrode sites is coupled to a
distinct row select line,
each column of biologic electrode sites is coupled to
25 a distinct column select line, and
each biologic electrode site comprises switching
circuitry responsive to a coincidence of select signals on
respective row and column select lines, said switching
circuitry providing an electrical connection between said
30 capacitor and an analog programming signal upon receiving
select signals on both of said respective row and column
select lines.

5. The biologic electrode matrix of claim 4, wherein each biologic electrode site further comprises an optical detector formed beneath said electrode, and each electrode is at least partially transparent.

5 6. An electrode site for use in a biologic electrode array, said site comprising:
an electrode,
a sample-and-hold circuit, and
an output amplifier coupled to said electrode and
10 said sample and hold circuit.

7. The electrode site of claim 6, wherein said sample-and-hold circuit comprises a capacitor coupled to a switching circuit, said switching circuit being responsive to a coincidence of select signals on respective row
15 and column select lines and providing an electrical connection between said capacitor and an analog programming signal upon receiving select signals on both of said respective row and column select lines.

8. The electrode site of claim 6, wherein said
20 sample-and-hold circuit comprises a capacitor coupled to a switching circuit, said switch circuit being controlled by an output of a two-input logic gate and, when closed, providing electrical communication between said capacitor and a voltage source line of said biologic electrode
25 array.

9. The electrode site of claim 6, wherein said sample-and-hold circuit comprises a capacitor coupled to a pair of CMOS transmission gates, said CMOS transmission gates being configured in series and, when closed,
30 providing electrical communication between said capacitor and a voltage source line formed within said biologic electrode array.

10. An electrode site for use in a biologic electrode array, said site comprising:

an electrode and an analog signal storage element coupled to said electrode via an amplifier circuit.

5 11. The electrode site of claim 10, wherein said analog signal storage element comprises a capacitor coupled to a switching circuit.

12. The electrode site of claim 11, wherein said switching circuit is controlled by an output of a two-
10 input logic gate and, upon receiving a selected output signal from said logic gate, provides electrical communication between said capacitor and a voltage source line of said biologic electrode array.

13. The electrode site of claim 10, wherein said
15 analog signal storage means comprises a capacitor coupled to a pair of CMOS transmission gates, said CMOS transmission gates being configured in series and, when closed, providing electrical communication between said capacitor and a voltage source line formed within said biologic
20 electrode array.

14. A biologic electrode array, comprising:

a memory;

a digital to analog converter coupled to said memory;

a counter;

25 a row decoder coupled to said counter and to said memory;

a column decoder coupled to said counter and to said memory; and

30 a matrix of active biologic electrodes coupled to said digital-to-analog converter, said row decoder and said column decoder; said matrix of active biologic electrodes having a plurality of biologic electrode sites arranged in a plurality of rows and columns; each said

biological site having an electrode and a sample-and-hold circuit coupled to said electrode via an amplifier circuit; said sample-and-hold circuit being coupled to a selected row
 5 select line, a selected column select line and a voltage source line of said matrix.

15. The biologic electrode array of claim 14, wherein said memory, said digital-to-analog converter, said counter, said row decoder, said column decoder, and said matrix are formed on a single semiconductor chip.

10

16. The biologic electrode array of claim 14, further comprising a sense amplifier coupled to each said electrode of said biologic electrode sites.

17. The biologic electrode array of claim 14, wherein an optical detector is disposed
 15 beneath at least one electrode of said biologic electrode sites and the electrode located at said at least one of said biologic sites is at least partially transparent.

18. The biologic electrode array of claim 17, wherein said at least one electrode comprises indium tin oxide.

20

19. The biologic electrode array of claim 17, wherein said at least one electrode comprises a slitted electrode structure for passing light therethrough.

20. The biologic electrode array of claim 17, wherein said at least one electrode
 25 comprises a punctuated electrode structure for passing light therethrough.

21. The biologic electrode array of claim 14 further comprising at least one heating element.



22. The biologic electrode array of claim 14 further comprising a plurality of heating elements which may be selectively controlled.

23. A site for use in a biologic electrode array,
5 said site comprising:

an electrode,

a driving element coupled to said electrode for applying an electrical stimulus to said electrode; and

10 a local memory coupled to said driving element for receiving and storing a signal indicative of a magnitude of said electrical stimulus to be applied to said electrode.

24. The site of claim 23, wherein said driving element comprises an amplifier and said local memory
15 comprises a capacitor.

25. The site of claim 24, wherein said capacitor is coupled to a signal source line of said biologic electrode array via a pair of switches, one switch being coupled to a row select line of said biologic array, and the other
20 switch being coupled to a column select line of said biologic array.

26. A method of controlling an electrical characteristic of an electrode within a biologic electrode array, said method comprising the steps of:

25 retrieving from a memory a value representing a voltage to be stored on at least one sample-and-hold circuit formed within said biologic electrode array, said sample-and-hold circuit being coupled to said electrode via an output amplifier;

30 providing said value to a digital-to-analog converter, said digital-to-analog converter generating a voltage proportional to said value and providing said

voltage to a conductor in electrical communication with said at least one sample-and-hold circuit; and

storing said voltage on said at least one sample-and-hold circuit.

5 27. The method of claim 26 wherein said steps of retrieving, providing and storing are periodically repeated to insure that said voltage stored on said sample-and-hold circuit remains within a preselected range of voltages.

10 28. A method of controlling an electrical characteristic of an electrode within a biologic electrode array, said method comprising the steps of:

addressing an electrode site within said biologic electrode array;

15 providing to a sample-and-hold circuit located at said addressed electrode site an electrical signal indicative of an electrical stimulus to be applied to an electrode located at said electrode site; and

20 allowing said sample-and-hold circuit located at said electrode site to cause said electrical stimulus to be applied to said electrode via a driving element.

25 29. The method of claim 28, wherein said biologic electrode array includes a plurality of row select lines and column select lines, said electrode site is coupled to a selected row select line and a selected column select line, and said addressing step is performed by providing electrical signals on said selected row and column select lines.

30 30. A method of controlling an electrical characteristic of an electrode within a biologic electrode array, said method comprising the steps of:

addressing an electrode site within said biologic electrode array;

providing to a local memory circuit located at said addressed electrode site an electrical signal indicative of an electrical stimulus to be applied to an electrode located at said electrode site; and

5 allowing said local memory circuit to communicate with a driving element located at said electrode site to control said electrical stimulus to be applied to said electrode.

10 31. An electronic device adapted to receive a solution including electrolytes and one or more charged specific binding entities, the device being adapted to affect the electrophoretic transport of the specific binding entities in the solution to selected locations on the device surface, the device comprising:

15 a plurality of addressable biologic electrode sites formed on a single integrated circuit chip,

wherein each electrode site comprises an electrode, an output amplifier circuit coupled to said electrode, an analog storage element coupled to said output amplifier circuit, and a switching circuit coupled to said analog storage element,

20 wherein the electrode of each electrode site has formed on a surface thereof a permeation layer for providing transport of counter-ions between the electrode and the solution, and

wherein the permeation layer of each electrode site has formed thereon a biologic attachment layer for enabling coupling with one or more selected binding entities from within the solution.

30 32. The electronic device of claim 31, wherein said plurality of biologic electrode sites are arranged in a plurality of rows and columns,

each row of biologic electrode sites is coupled to a distinct row select line,

each column of biologic electrode sites is coupled to a distinct column select line, and

the switching circuit of each biologic electrode site is responsive to a coincidence of select signals on respective row and column select lines and provides an electrical connection between the analog storage element coupled thereto and an analog programming signal upon receiving select signals on both of said respective row and column select lines.

33. Apparatus for a multiplexed active biologic array with reference to any one of the embodiments as that embodiment is illustrated in the drawings.

34. Method for a multiplexed active biologic array with reference to any one of the embodiments as that embodiment is illustrated in the drawings.

15

DATED this Twenty-third Day of December 1998

Nanogen, Inc.

Patent Attorneys for the Applicant

SPRUSON & FERGUSON

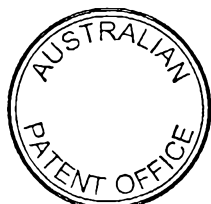

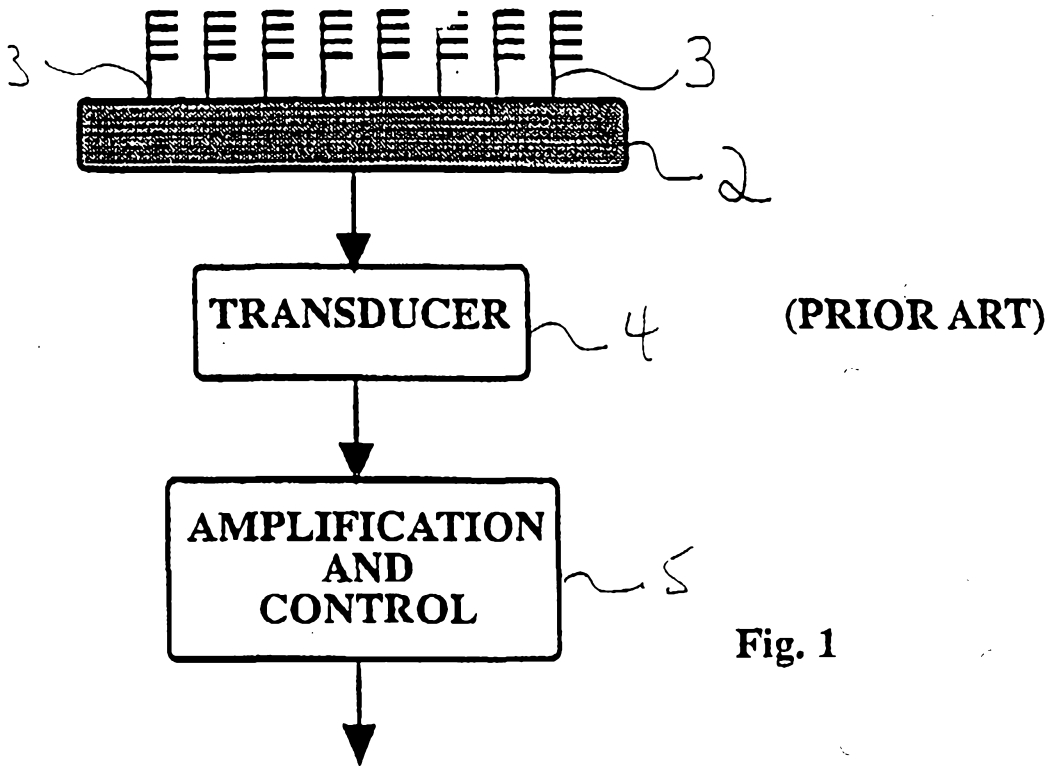
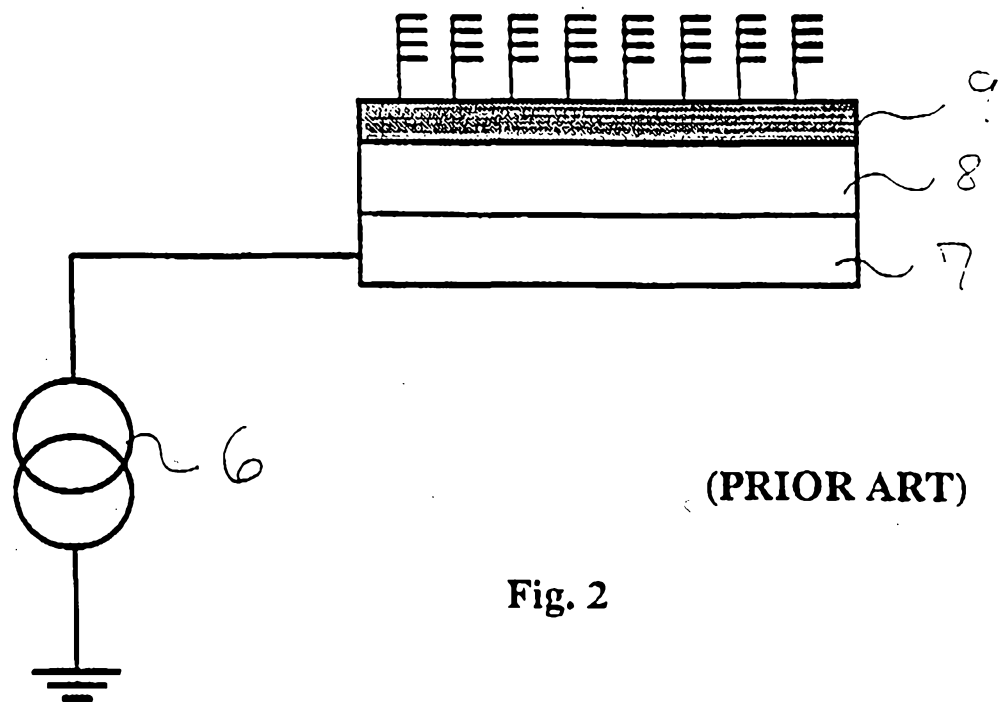

Fig. 1



(PRIOR ART)

Fig. 2

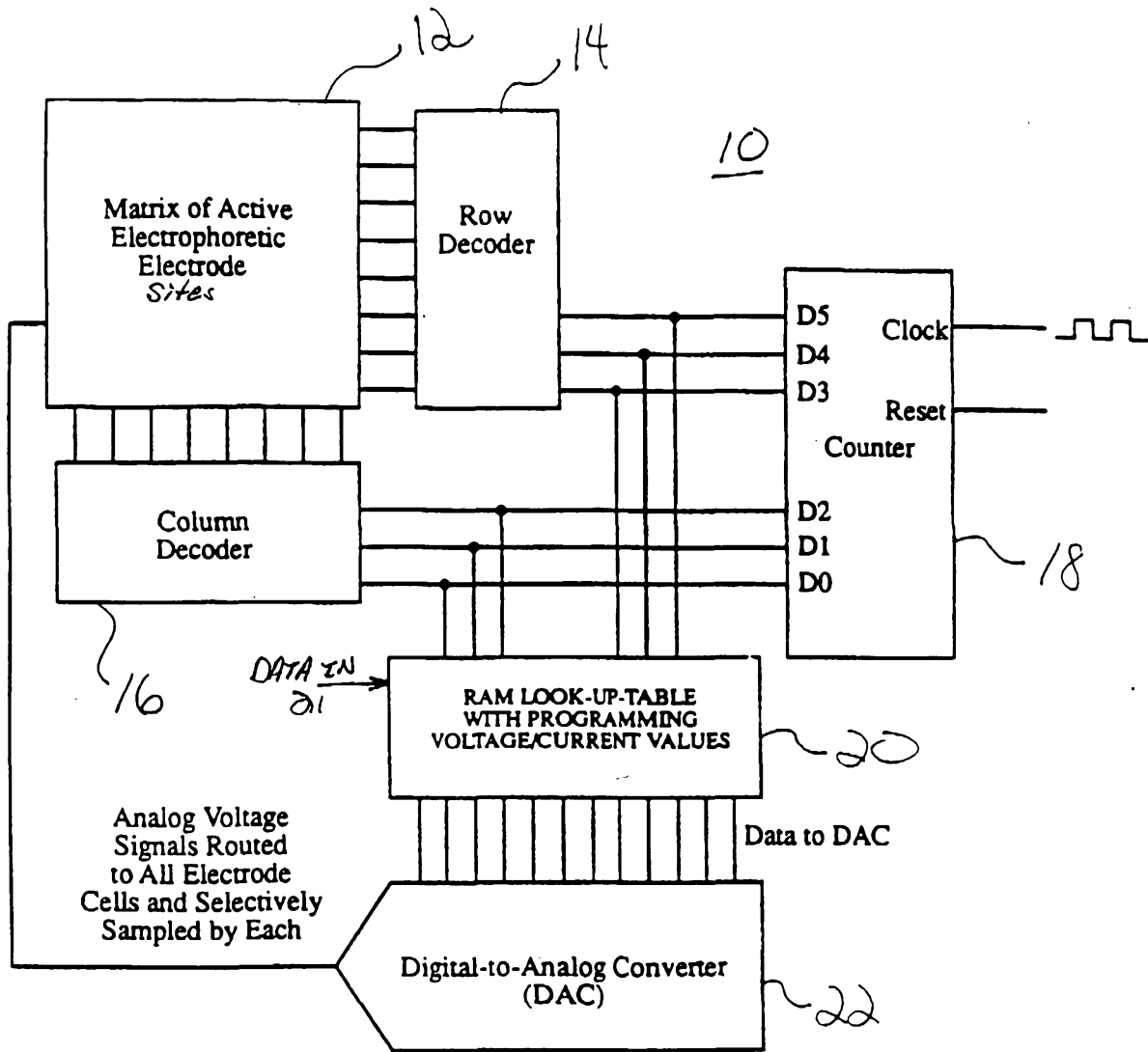

Fig. 3

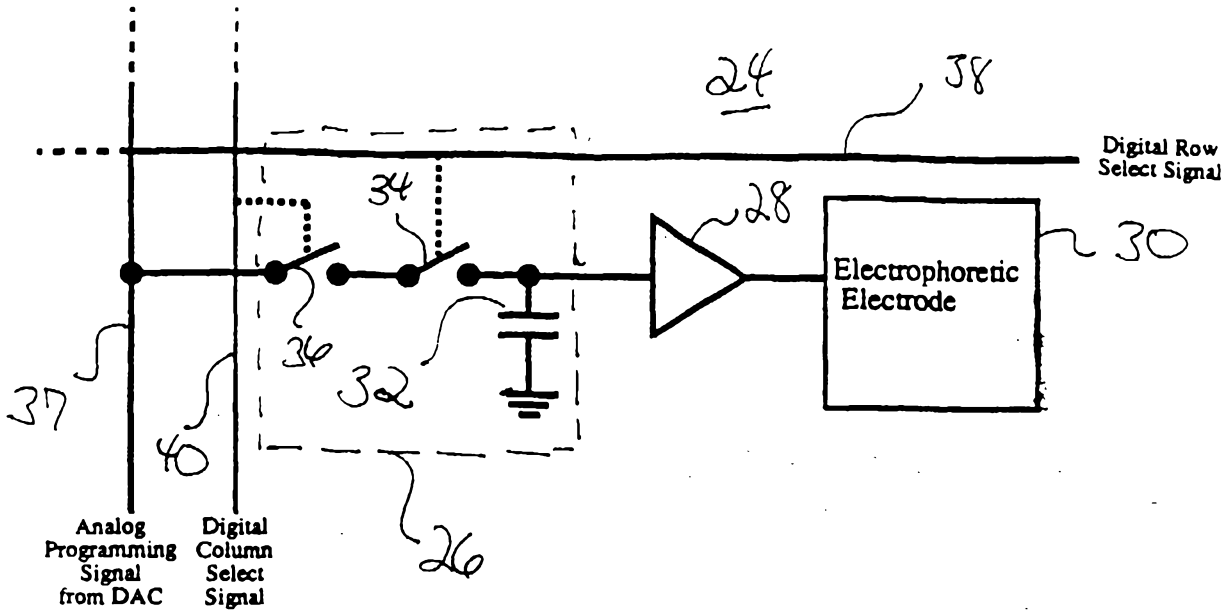

Fig. 4(a)

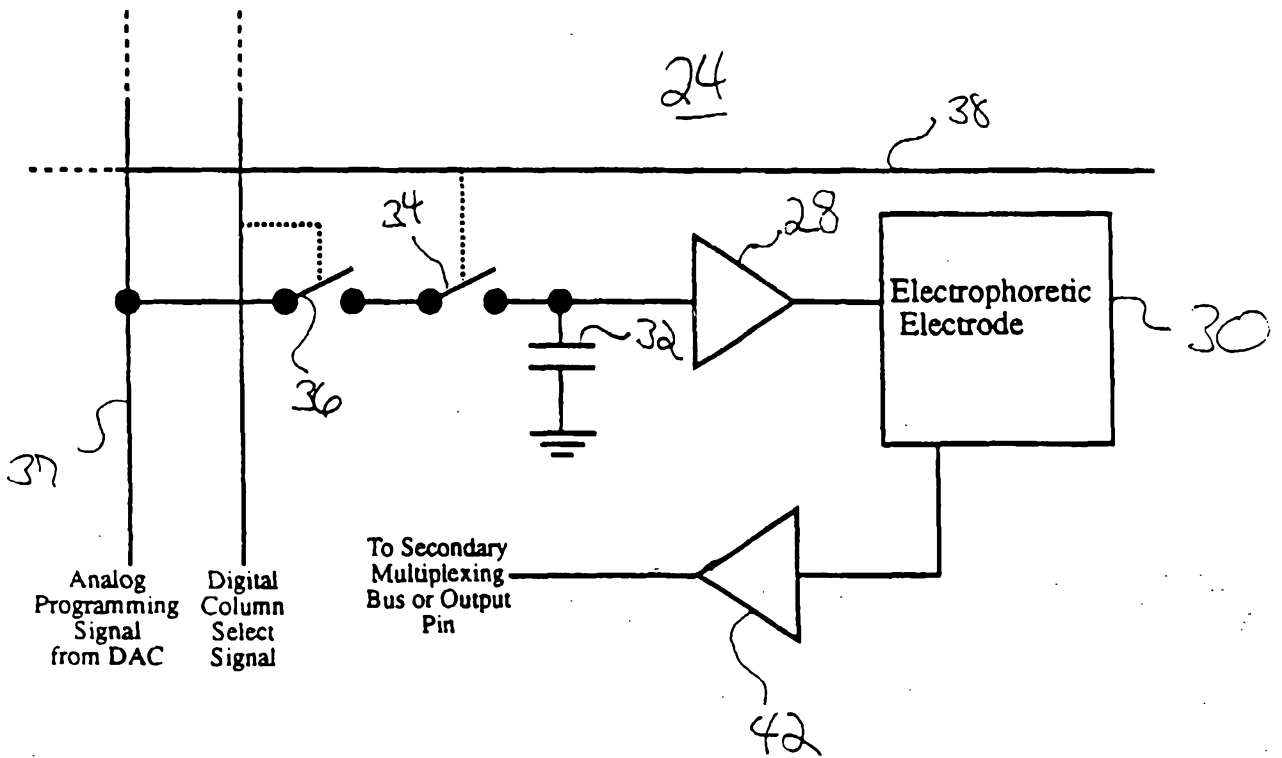
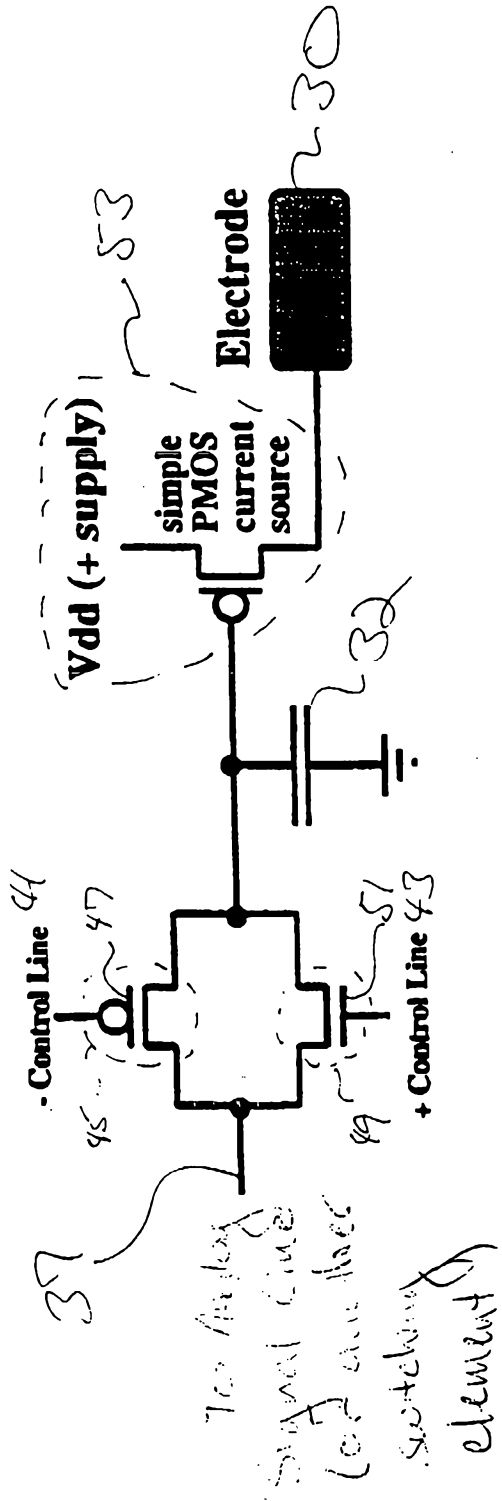
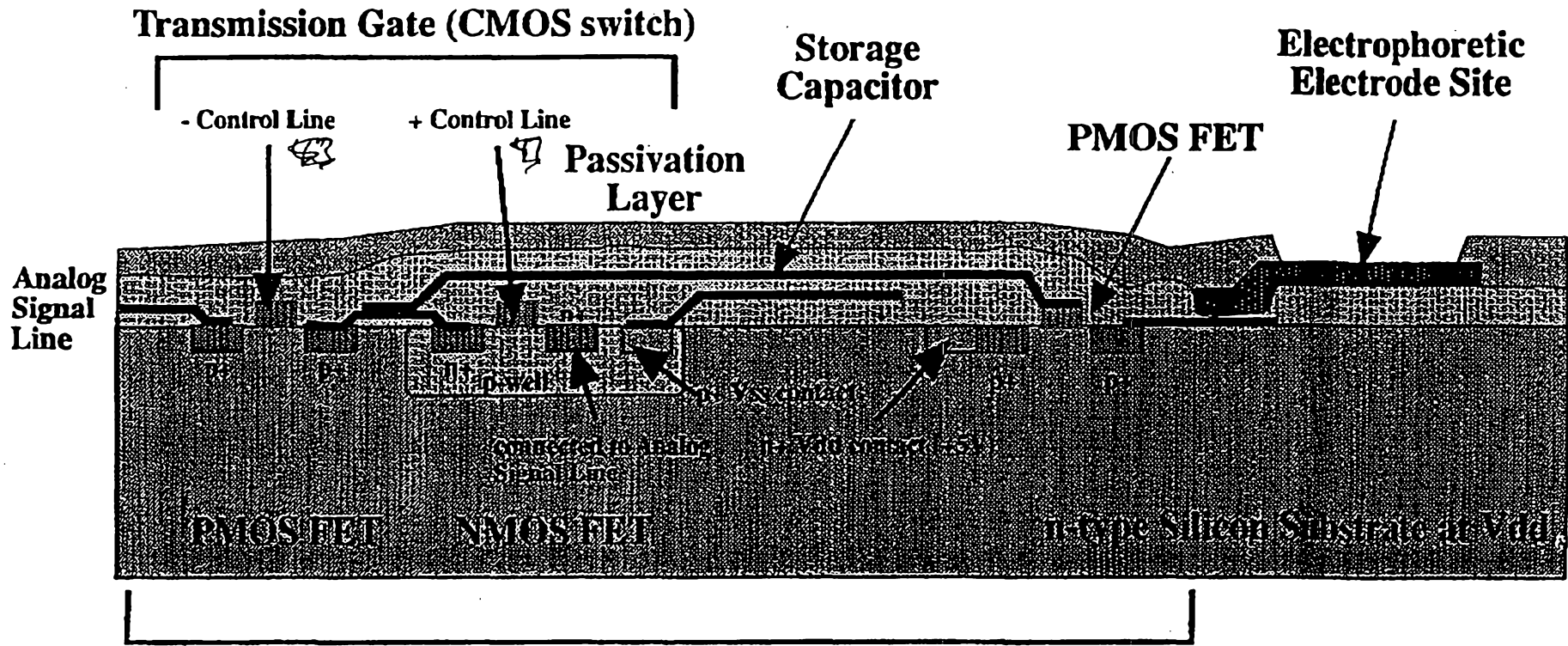

Fig. 5





5/8

Pre-Fabricated CMOS Circuits

Fig. 4(c)

6/8

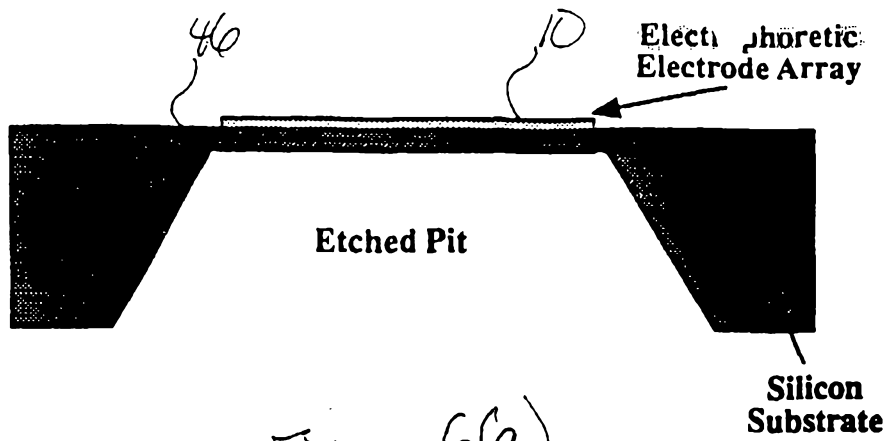

Fig. 6(a)

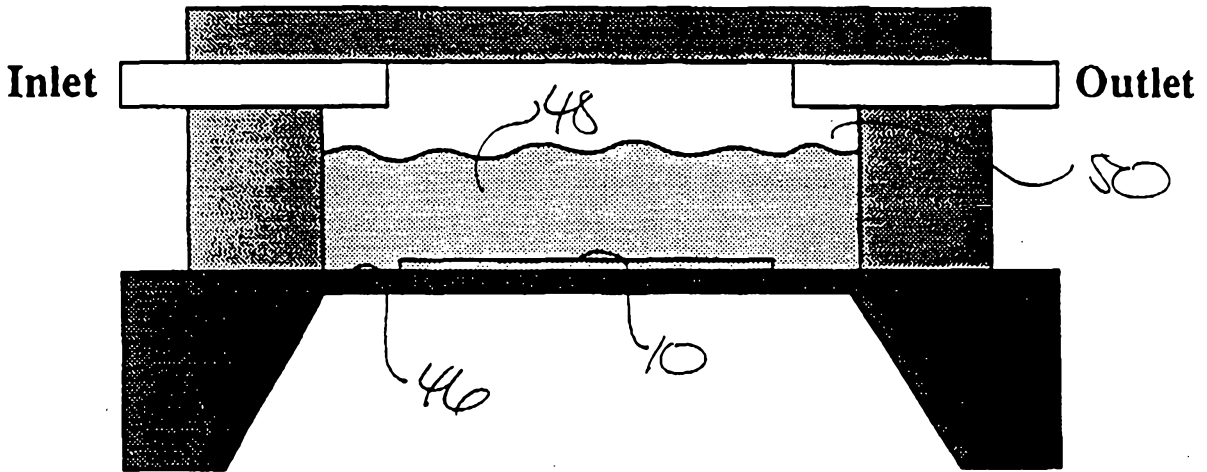

Fig. 6(b)

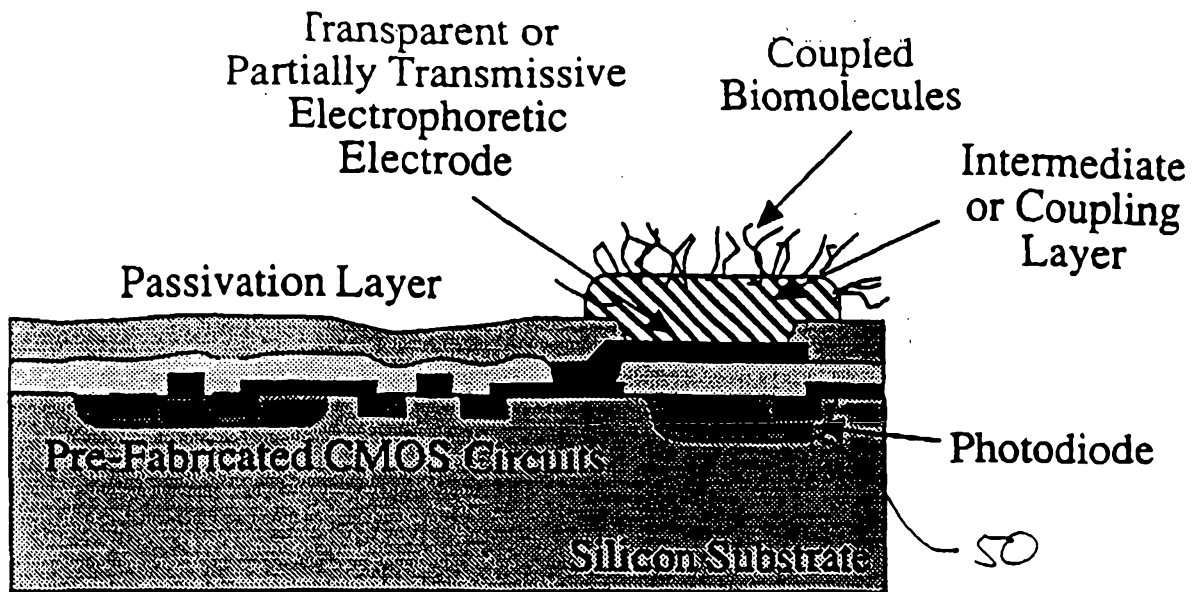

Fig. 7

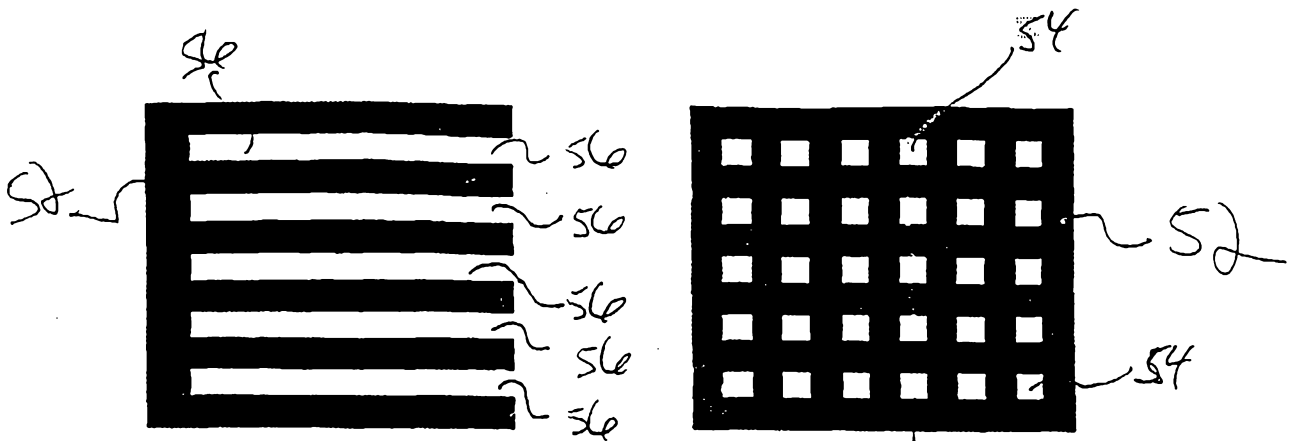

Fig 8(b)

Fig. 8(a)

Direct Optical Path to Photodetector