



INTERNATIONAL APPLICATION PUBLISHED UNDER THE PATENT COOPERATION TREATY (PCT)

<p>(51) International Patent Classification⁶ : H04R 1/10, 5/033</p>	<p>A1</p>	<p>(11) International Publication Number: WO 99/48324</p> <p>(43) International Publication Date: 23 September 1999 (23.09.99)</p>
<p>(21) International Application Number: PCT/GB99/00720</p> <p>(22) International Filing Date: 10 March 1999 (10.03.99)</p> <p>(30) Priority Data: 9805618.7 18 March 1998 (18.03.98) GB</p> <p>(71) Applicant (for all designated States except US): NCT GROUP, INC. [US/US]; 1025 West Nursery Road, Linthicum, MD 21090-1206 (US).</p> <p>(72) Inventor; and (75) Inventor/Applicant (for US only): JONES, Owen [GB/GB]; Waterrun Cottage, Mill Lane, Chattisham, Ipswich IP8 3PX (GB).</p> <p>(74) Agent: STONE, Patrick; 28 Edenside Drive, Attleborough, Norfolk NR17 2EL (GB).</p>	<p>(81) Designated States: AU, CA, CN, JP, KR, SG, US, European patent (AT, BE, CH, CY, DE, DK, ES, FI, FR, GB, GR, IE, IT, LU, MC, NL, PT, SE).</p> <p>Published <i>With international search report.</i></p>	

(54) Title: HEADSET FOR AIRCRAFT

(57) Abstract

An active noise reduction (ANR) headset, especially for use by aircraft passengers, wherein each earphone comprises at least two parts, one carried by the headband (108), the other part (101) connecting both mechanically and electrically to the first part, wherein the component or components requiring frequent replacement are carried by one part and the second part is available for re-use.

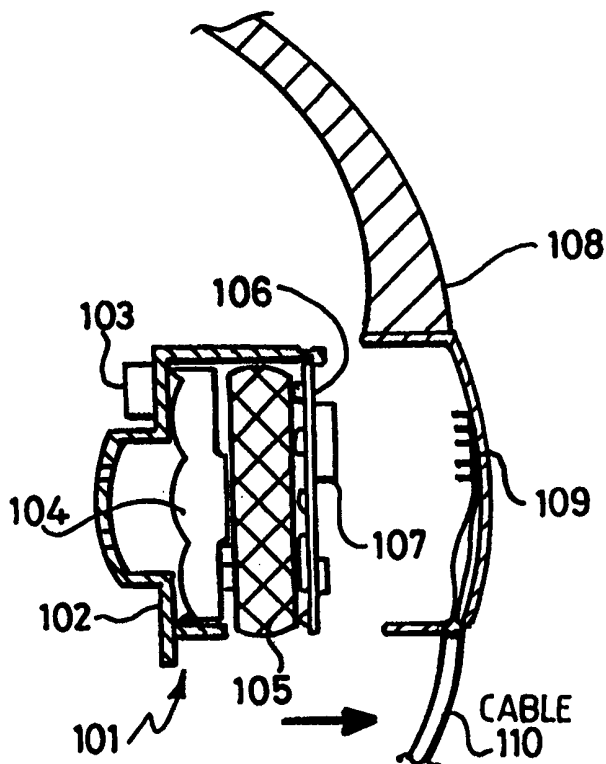

FOR THE PURPOSES OF INFORMATION ONLY

Codes used to identify States party to the PCT on the front pages of pamphlets publishing international applications under the PCT.

AL	Albania	ES	Spain	LS	Lesotho	SI	Slovenia
AM	Armenia	FI	Finland	LT	Lithuania	SK	Slovakia
AT	Austria	FR	France	LU	Luxembourg	SN	Senegal
AU	Australia	GA	Gabon	LV	Latvia	SZ	Swaziland
AZ	Azerbaijan	GB	United Kingdom	MC	Monaco	TD	Chad
BA	Bosnia and Herzegovina	GE	Georgia	MD	Republic of Moldova	TG	Togo
BB	Barbados	GH	Ghana	MG	Madagascar	TJ	Tajikistan
BE	Belgium	GN	Guinea	MK	The former Yugoslav Republic of Macedonia	TM	Turkmenistan
BF	Burkina Faso	GR	Greece	ML	Mali	TR	Turkey
BG	Bulgaria	HU	Hungary	MN	Mongolia	TT	Trinidad and Tobago
BJ	Benin	IE	Ireland	MR	Mauritania	UA	Ukraine
BR	Brazil	IL	Israel	MW	Malawi	UG	Uganda
BY	Belarus	IS	Iceland	MX	Mexico	US	United States of America
CA	Canada	IT	Italy	NE	Niger	UZ	Uzbekistan
CF	Central African Republic	JP	Japan	NL	Netherlands	VN	Viet Nam
CG	Congo	KE	Kenya	NO	Norway	YU	Yugoslavia
CH	Switzerland	KG	Kyrgyzstan	NZ	New Zealand	ZW	Zimbabwe
CI	Côte d'Ivoire	KP	Democratic People's Republic of Korea	PL	Poland		
CM	Cameroon	KR	Republic of Korea	PT	Portugal		
CN	China	KZ	Kazakstan	RO	Romania		
CU	Cuba	LC	Saint Lucia	RU	Russian Federation		
CZ	Czech Republic	LI	Liechtenstein	SD	Sudan		
DE	Germany	LK	Sri Lanka	SE	Sweden		
DK	Denmark	LR	Liberia	SG	Singapore		
EE	Estonia						

-1-

Headset for Aircraft

This invention relates to a headset more especially but not exclusively intended for use by aircraft passengers.

The headsets used in aircraft for the in-flight entertainment generally have a short lifetime due to the abuse they receive in handling and cleaning and this means that airlines require the headsets to be low cost in order to keep replacement costs down. This unfortunately means that the performance of the headsets is often relatively poor and this exacerbates the problems of poor intelligibility of the entertainment programmes due to the high levels of background noise present on aircraft.

Airlines would like to be able to use active noise reduction (ANB) headsets to counter the background noise problem but, although the cost of such headsets has come down dramatically in recent years, they are still too costly for general use in aircraft.

The reasons for the high cost of an active headset are twofold. The first is that a high quality microphone has to be closely associated with each earphone and the cost of this microphone and associated wiring adds appreciably to the costs. The second reason is that electronics have to be added to the system in order to implement the noise cancellation process. It is possible to separate the electronics from the headset (for example as described in patent publication No. PCT/US94/0727), but this means that the seat processor unit (PCU) has to be modified and requires an aircraft re-fit. This is an expensive option. If, however, the electronics are housed within the headset then the headset cost tends to become prohibitive.

-2-

The purpose of this invention is to describe means whereby these compromises can be avoided, more especially by implementing a modular ANR headset that can be readily altered from normal to active modes by choice of module and in which only the very low cost parts of the headset assembly need be regularly replaced.

By carefully controlling the acoustics of an ANR headset it is possible to reduce the size of the electronic assembly required to house the electronics within the headset. As explained above, this option is still too expensive for airlines as the headset has to be discarded after only a short amount of use. It is generally the main mechanical parts of a headset that break or deteriorate, such as the headband, cable and exterior finish; the drive unit itself is fairly robust.

It is therefore a further aim of this invention to house the electronics and the important acoustical elements within a replaceable module such that they can be fitted into a replacement headset by unskilled personnel in the field, without needing any adjustment for optimum performance.

According to the invention, there is provided a headset assembly having active noise reduction (ANR) for environmental noise comprising for each ear a first part carried by the headband and a second part including at least a circuit board bearing the ANR electronics, the second part being mechanically and electrically separable from the first part, electrical connection and separation being enabled by means of a plug and a socket on the respective parts.

This construction of headset assembly enables, in particular, its configuration either as a conventional headset or an active headset, and its ready conversion from one to the other.

Several forms of this headset assembly are envisaged.

-3-

In one form the first part comprises an earphone shell and the second part comprises, in addition to the ANR electronics, a baffle plate and a drive unit and sensing microphone carried by the baffle plate. In embodiments of this form, the first part is adapted to receive an alternative second part comprising a baffle plate and drive unit for providing conversion to a non-active headset.

In a second form of embodiment, the first part comprises a baffle plate and the second part includes an earphone shell, and at least a sensing microphone and ANR electronics carried by the shell. In a modification, the second part also includes the drive unit.

In a third form of embodiment, the second part comprises the ANR electronics, and may also include a cover part for completing the earphone shell.

In a fourth form of embodiment, the baffle plate has an opening in front of the drive unit and a vented space is enclosed on the rear side of the drive unit remote from the baffle plate opening, the size of the vent being adjustable.

The invention is further described with reference to the accompanying drawings, in which:-

Figure 1 illustrates one embodiment of headset;

Figure 2 shows a substitute module;

Figure 3 illustrates a second embodiment of headset;

Figure 4 illustrates a modification;

Figure 5 illustrates a third embodiment of headset;

-4-

Figure 6 shows a modification; and

Figure 7 shows a fourth embodiment of headset.

Referring first to Figure 1, the module 101 consists of a baffle assembly 102 which holds the sensing microphone 103, earphone drive unit 104, acoustic treatment 105, electronics module 106 and socket 107. This module snaps into place into the headset assembly 108, electrical connection therefor being made between socket 107 and plug 109. All elements of the headphone assembly 108 can be low cost since they are not required to last very long. This is a principal reason for putting the plug in the headset assembly, as it can be made to a lower cost than a socket. The socket 107, plug 109 and cable 110 bring the audio signal and power up from an interface in the aircraft seat.

The cancellation module 101 is self contained and can be set up for optimum performance in production. The acoustics will not be significantly altered from the designed-for characteristics when inserted into different headphone assemblies 108 by untrained staff. In fact, the headset assembly 108 can be of different styles provided in all cases it has been designed not to interfere with the acoustics of the module.

The headset can be converted into a standard non-active version by plugging in module 111, shown in Figure 2. This contains only an earphone and socket 107 and so is still very low cost. The number of connections on the socket can be reduced to two and be of a low quality as it will not be required to last very long.

In a second embodiment shown in Figure 3 the active module 121 is inserted into the headset assembly 128 in a different way. In this arrangement, the baffle plate 122 is part of the headphone assembly 128 and the active module 121 is slid

-5-

in from the top. This option means that virtually all external surfaces of the headphone are replaced when the headset is changed and so there is no build up of scuff marks to detract from the appearance of the headset. In Figure 2, the illustrated components of the module are the earphone shell carrying the ANR electronics 126 and socket 127, as well as the sensing microphone 123. The baffle plate 122 carries the drive unit 124 and plug 129.

A modification shown in Figure 4 and using the same reference numerals as Figure 3 with the suffix A makes it possible also to replace the drive unit each time the rest of the headset assembly is replaced. This requirement may arise if, for example, the cleaning process is one that might subject the drive unit to potential damage. In this situation the drive unit can be a part of the earphone shell module, with the baffle plate 122A carrying only the plug 129A. The active module can be plugged or slotted into the headset in either of the ways shown in Figures 1 and 2 or Figure 3.

With this arrangement, there arises the possibility of variations in the performance due to differences in the drive unit sensitivity. To avoid this difficulty, the drive unit is either selected to the desired tolerance, or else the sensitivity adjusted on the production line by means, for example, of a variable resistor in series with the drive unit.

The increase in cost of this approach over that of a standard headset is minimal since the variable resistor can be mounted on the same PCB that is commonly used to terminate the drive unit voice coil wires.

A third embodiment shown in Figure 5 makes it possible to replace the microphone regularly. In this case only the ANR electronics 142 are incorporated into the plug-in module. The microphone requires a sensitivity adjustment pot but the drive unit pot may be dispensed with, or vice versa, one

-6-

adjustment being adequate for the two transducers. The ANR electronics 142 can slot in as shown in Figure 5, together with a cover plate 141 which completes the earpiece shell, or else it can be completely inserted into the headset behind an integral cover 143, as shown in Figure 6. With this embodiment the headset assembly can also be configured as a conventional passive headset by omitting the electronics.

A fourth embodiment shown in Figure 7 and using the same reference numerals as Figure 1 with the suffix A allows the acoustic properties of the replaceable module to be tuned to match the characteristics of different earpads, e.g. leatherette or foam.

The module 101A still fits into headset assembly 108A, but in this embodiment the module diameter is smaller than the rear shell 113A. The module 101A incorporates a rear housing that encloses the rear of the drive unit 104A in baffle 102A, apart from a vent formed by aperture 114A and shutter 115A. The aperture 114A may comprise a series of small holes or a number of slots. The shutter is arranged such that it can partially or completely cover the aperture thereby altering the acoustic loading on the drive unit and changing its response. The shutter can be adjusted in production to compensate either for different drive unit characteristics or for a variety of styles of earpad and the materials used for its construction.

The shutter can in its simplest form be a tube of diameter slightly larger than the rear housing, that is slid into the correct position and secured in place by screwing or gluing, or a thread may be formed in manufacture allowing the shutter to be positioned by rotating it, or else a ratchet mechanism may be employed in order to dispense with any other form of fixing. Any gap between the shutter and housing may be closed by having a layer of felt between the housing and shutter.

-7-

The rear housing may be designed to enclose the circuit board, or else the circuit board could form the end of the housing. In either instance, the housing can be designed to allow the circuit board to be positioned at a variety of distances from the drive unit thereby allowing the volume of the cavity behind the drive unit to be adjusted.

To save further costs the microphone may also be made removable so that one headset moulding can suit all purposes. In the field the headset can then quickly be re-configured from passive to active mode just by plugging in a microphone and electronics module from a spares bin. It is preferable in this case to include sensitivity adjustments on both the microphone and the drive unit.

In the foregoing description it has been assumed for simplicity that power is provided to the headset through the cable that picks up the audio signal from the seat. There are several ways that this could be implemented, with various options on the number of connections that would be required.

However, other possibilities exist for powering the headset described in the present specification. Batteries may be used in the active module, but these would require replacement by the cabin crew at irregular intervals dependent upon the actual use of the headset and would require a stock of batteries to be held on board the aircraft. The cost and impracticability of such a scheme would be detrimental to the acceptance of the headset.

An alternative would be to put the batteries into the replaceable headset assembly. In this way the batteries would be automatically changed at the schedule replacement intervals of the headset assembly. Some extra cost would be incurred due to light use batteries being discarded, but overall costs would be lower.

-8-

The batteries may be zinc-air types. These have a very high energy density and so are small and lightweight, but at the expense of needing to be used continually until exhaustion to obtain the maximum capacity. This would not necessarily be a problem with use of the headset in commercial airlines, as the aircraft has to be kept in almost perpetual use due to the cost of downtime.

However, in order for this approach to be successful the power drain of the electronics requires to be kept as low as possible. Only so much can be accomplished by careful design. For applications where the use may be more intermittent it would be desirable to be able to turn the headset on and off. This could easily be accomplished with a manually operated switch but the likelihood is that this would be forgotten by the cabin crew as the headsets are collected. Because the headband has only a limited life, an ON/OFF switch may be constructed into the headband as a very cheap mechanism that turns the headset on when the headband is stretched open to be worn, as it will not have to last for long. It may even be made part of the battery contact mechanism.

Several schemes for automatically reducing power consumption, based upon sound pressure level or detection of whether or not the headset is in position on the head, have also been proposed. These proposals are also applicable to the present headset implementation, but a further possibility arises from the controlled situation in which these headsets will be used. The headset will only be used when a passenger is seated and therefore the electronics can be designed to only power up the main cancellation circuitry when it receives a control signal from the aircraft entertainment system once the headset is plugged into the seat.

The control signal could be an inaudible infrasonic or ultrasonic tone that is mixed into the entertainment signal path. The headset would incorporate a very low power detection system that would only bring the rest of the electronics to

-9-

life on receipt of the tone. Alternatively a DC offset could be added to the entertainment signal that the headset could recognise.

Claims

1. A headset assembly having active noise reduction (ANR) for environmental noise comprising for each ear a first part carried by the headband and a second part including at least a circuit board bearing the ANR electronics, the second part being mechanically and electrically separable from the first part, electrical connection and separation being enabled by means of a plug and a socket on the respective parts.
2. A headset assembly according to claim 1, wherein the first part comprises an earphone shell and the second part comprises, in addition to the ANR electronics, a baffle plate and a drive unit and a sensing microphone.
3. A headset assembly according to claim 2, wherein the baffle plate has an opening in front of the drive unit and a vented space is enclosed on the rear side of the drive unit remote from the baffle plate opening, the size of the vent being adjustable.
4. A headset assembly according to claim 3, wherein the volume of the vented space is adjustable.
5. A headset assembly according to claim 3 or claim 4, wherein the baffle plate has a rear, apertured tubular extension closed at or towards its rear end by the circuit board.
6. A headset assembly according to claim 5, including a movable shutter cooperating with the apertured region of the extension.
7. A headset assembly according to claim 5 or claim 6 when appendant to claim

-11-

4, wherein the position of the circuit board is axially adjustable in the tubular extension.

8. A headset assembly according to any of claims 2 to 7, wherein the first part is adapted to receive an alternative second part comprising a baffle plate and drive unit for providing conversion to a non-active headset.

9. A headset assembly according to any of claims 1 to 8, wherein, for the purpose of establishing electrical connection and separation between the two parts, the first part carries the electrical plug and the second part carries the electrical socket.

10. A headset assembly according to claim 1, wherein the first part comprises a baffle plate and the second part includes an earphone shell, and at least a sensing microphone and ANR electronics carried by the shell.

11. A headset assembly according to claim 10, wherein the second part also includes a drive unit.

12. A headset assembly according to claim 10 or claim 11, wherein the second part is slidably engageable with the first part.

13. A headset assembly according to claim 11 or claim 12 when appendant to claim 11, wherein the drive unit has a variable resistor associated therewith for sensitivity adjustment.

14. A headset assembly according to claim 1, wherein the second part comprises the ANR electronics.

15. A headset assembly according to claim 14, wherein the first part includes a

-12-

potentiometer associated with the sensing microphone for sensitivity adjustment.

16. A headset assembly according to claim 14 or claim 15, wherein the second part includes a cover for completing the earphone shell.

17. A headset assembly according to any of claims 1 to 16, wherein the sensing microphone is also a separable part.

18. A headset assembly according to any of claims 1 to 17, for use in an aircraft, and adapted to receive a drive signal via a cable which is connectable to a passenger seat.

19. A headset assembly according to claim 18, also adapted to receive a power signal on the cable which is connectable to the seat.

20. A headset assembly according to claim 18, which is battery powered.

21. A headset assembly according to claim 20, wherein the battery is incorporated in the first part of the assembly.

22. A headset assembly according to claim 21, wherein the batteries are zinc/air batteries.

23. A headset assembly according to claim 21 or claim 22, wherein an on/off power switch is incorporated in the headband of the assembly and is automatically switched on when the headband is stretched.

24. A headset according to any of claims 20 to 22, wherein the power is switched on by detection of an electrical signal received when the cable is plugged into the seat.

-13-

25. A headset assembly having the potential for active noise reduction (ANR) for environmental noise, comprising for each ear a first part carried by the headband and a second part comprising a baffle plate and a drive unit for a non-ANR headset, the second part being mechanically and electrically separable from the first part by plug and socket means on the respective parts, whereby to make possible conversion of the headset assembly to one having ANR, by substituting a second part including an ANR circuit board.

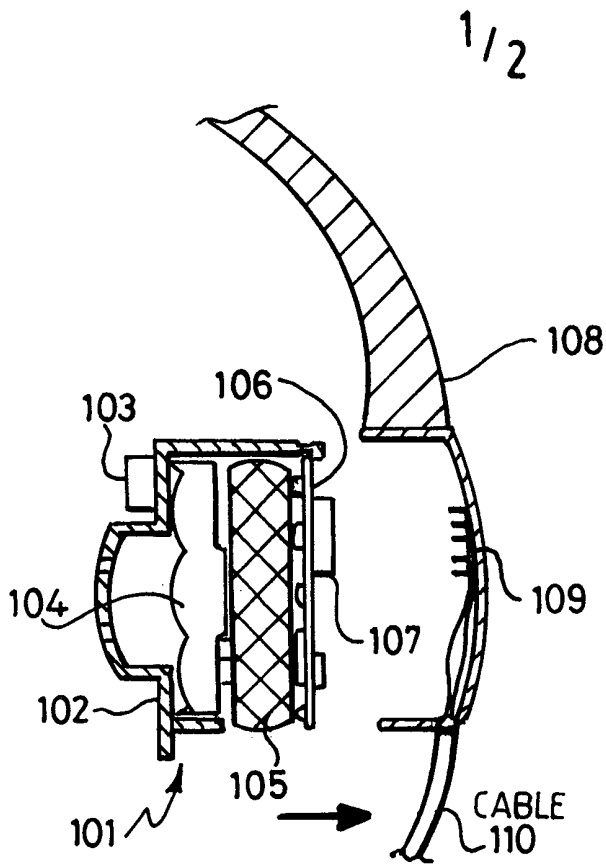

Fig. 1

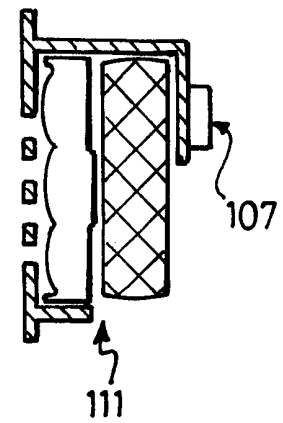

Fig. 2

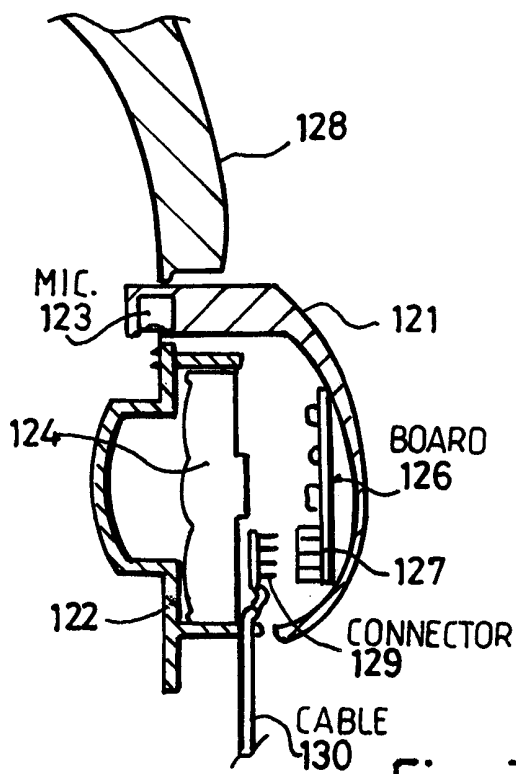

Fig. 3

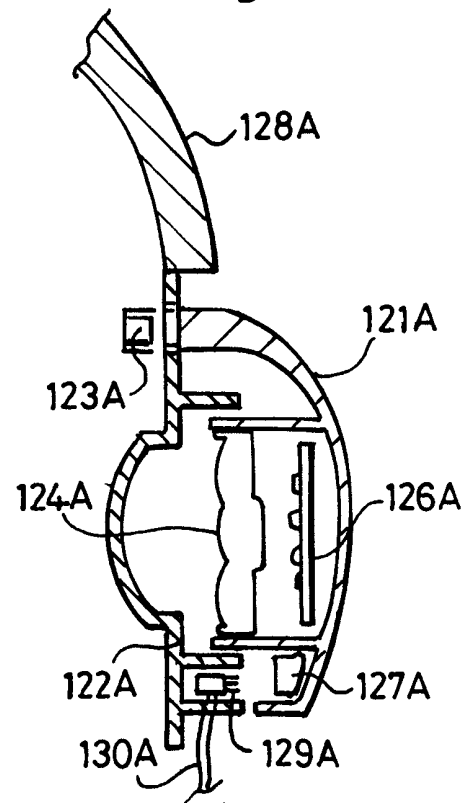

Fig. 4

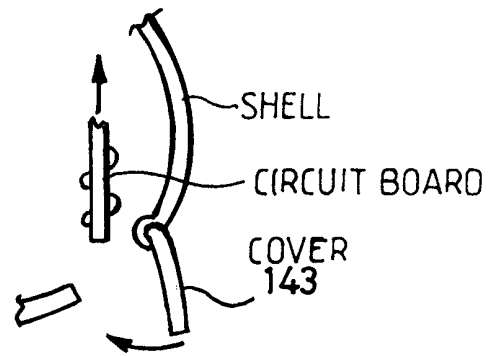
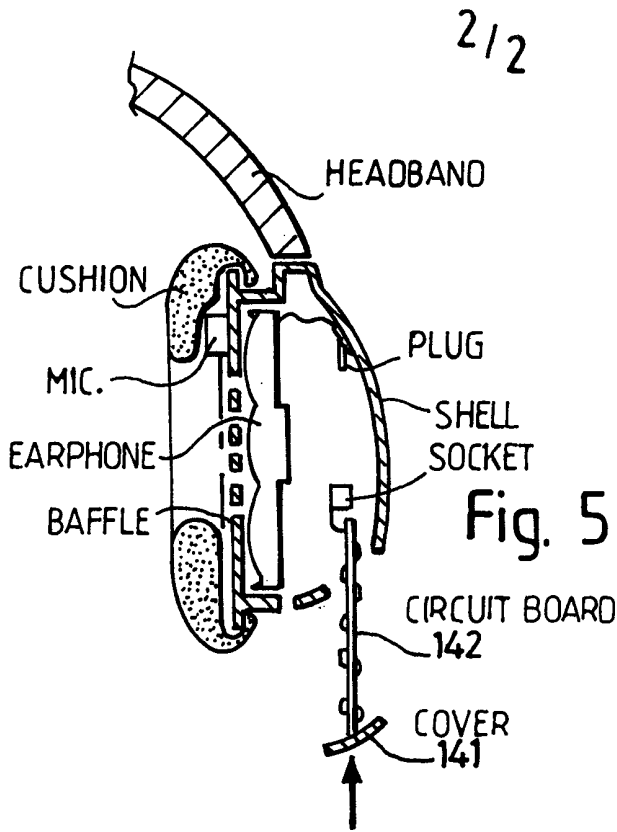
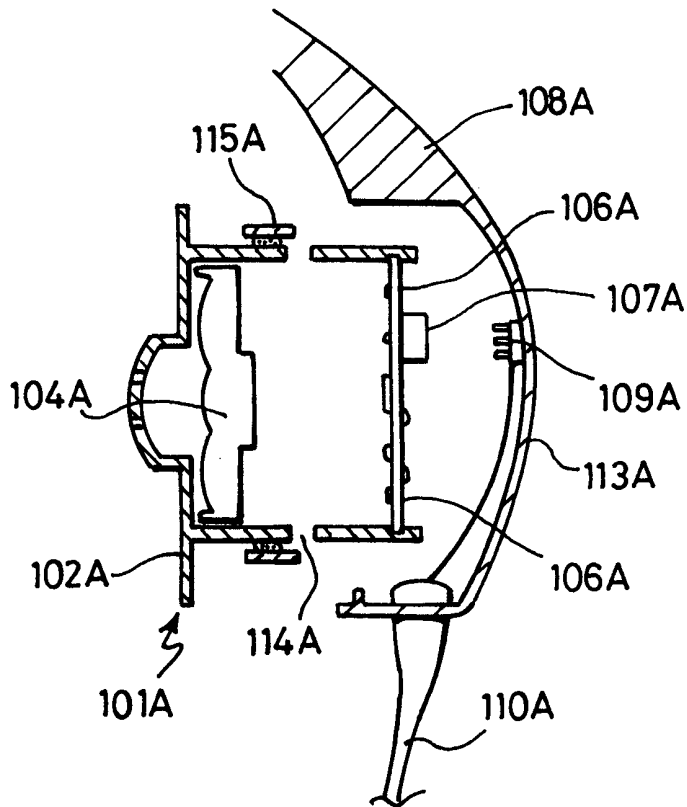

Fig. 6



INTERNATIONAL SEARCH REPORT

International Application No.
PCT/GB 99/00720

A. CLASSIFICATION OF SUBJECT MATTER H 04 R 1/10, H 04 R 5/033		
According to International Patent Classification (IPC) or to both national classification and IPC		
B. FIELDS SEARCHED Minimum documentation searched (classification system followed by classification symbols) H 04 M, H 04 R		
Documentation searched other than minimum documentation to the extent that such documents are included in the fields searched		
Electronic data base consulted during the international search (name of data base and, where practical, search terms used)		
C. DOCUMENTS CONSIDERED TO BE RELEVANT		
Category *	Citation of document, with indication, where appropriate, of the relevant passages	Relevant to claim No.
A	GB 2176672 A (HUANG-KIANG HOUNG) 31 December 1986 (31.12.86), the whole document. ---	1
A	US 4517418 A (BARAN et al.) 14 May 1985 (14.05.85), abstract, fig. 1, claim 1. ---	1
A	GB 2279202 A (FOGARTY, M.J.) 21 December 1994 (21.12.94). -----	
<input type="checkbox"/> Further documents are listed in the continuation of box C.		
<input checked="" type="checkbox"/> Patent family members are listed in annex.		
* Special categories of cited documents :		
A document defining the general state of the art which is not considered to be of particular relevance *E* earlier document but published on or after the international filing date *L* document which may throw doubts on priority claim(s) or which is cited to establish the publication date of another citation or other special reason (as specified) *O* document referring to an oral disclosure, use, exhibition or other means *P* document published prior to the international filing date but later than the priority date claimed		
T later document published after the international filing date or priority date and not in conflict with the application but cited to understand the principle or theory underlying the invention *X* document of particular relevance; the claimed invention cannot be considered novel or cannot be considered to involve an inventive step when the document is taken alone *Y* document of particular relevance; the claimed invention cannot be considered to involve an inventive step when the document is combined with one or more other such documents, such combination being obvious to a person skilled in the art. *&* document member of the same patent family		
Date of the actual completion of the international search 17 May 1999	Date of mailing of the international search report 02. 06. 1999	
Name and mailing address of the ISA European Patent Office, P.B. 5818 Patentlaan 2 NL - 2280 HV Rijswijk Tel. (+ 31-70) 340-2040, Tx. 31 651 epo nl, Fax (+ 31-70) 340-3016	Authorized officer GRÖSSING e.h.	

ANHANG

zum internationalen Recherchenbericht über die internationale Patentanmeldung Nr.

ANNEX

to the International Search Report to the International Patent Application No.

ANNEXE

au rapport de recherche international relatif à la demande de brevet international n°

PCT/GB 99/00720 SAE 227531

In diesem Anhang sind die Mitglieder der Patentfamilien der im obengenannten internationalen Recherchenbericht angeführten Patentdokumente angegeben. Diese Angaben dienen nur zur Unterrichtung und erfolgen ohne Gewähr.

This Annex lists the patent family members relating to the patent documents cited in the above-mentioned international search report. The Office is in no way liable for these particulars which are given merely for the purpose of information.

La présente annexe indique les membres de la famille de brevets relatifs aux documents de brevets cités dans le rapport de recherche international visée ci-dessus. Les renseignements fournis sont donnés à titre indicatif et n'engagent pas la responsabilité de l'Office.

Im Recherchenbericht angeführtes Patentdokument Patent document cited in search report Document de brevet cité dans le rapport de recherche		Datum der Veröffentlichung Publication date Date de publication	Mitglied(er) der Patentfamilie Patent family member(s) Membre(s) de la famille de brevets	Datum der Veröffentlichung Publication date Date de publication
GB A1	2176672	31-12-1986	GB A0 8515136 GB B2 2176672	17-07-1985 05-07-1989
US A	4517418	14-05-1985	keine - none - rien	
GB A1	2279202	21-12-1994	GB A0 9311916 GB A0 9410713 GB B2 2279202	28-07-1993 13-07-1994 21-05-1997