

(19) World Intellectual Property
Organization
International Bureau



(43) International Publication Date
29 December 2004 (29.12.2004)

PCT

(10) International Publication Number
WO 2004/113783 A1

(51) International Patent Classification⁷: **F16M 11/00**,
11/16, A61N 5/06

(21) International Application Number:
PCT/IB2004/050963

(22) International Filing Date: 22 June 2004 (22.06.2004)

(25) Filing Language: English

(26) Publication Language: English

(30) Priority Data:
03101887.2 25 June 2003 (25.06.2003) EP

(71) Applicant (for all designated States except US): **KONIN-
KLIJKE PHILIPS ELECTRONICS N.V.** [NL/NL];
Groenewoudseweg 1, NL-5621 BA Eindhoven (NL).

(72) Inventors; and

(75) Inventors/Applicants (for US only): **TAEKEMA, Harko,
J.** [NL/NL]; c/o Prof. Holstlaan 6, NL-5656 AA Eindhoven
(NL). **HILLE, Rogier** [NL/NL]; c/o Prof. Holstlaan 6,
NL-5656 AA Eindhoven (NL).

(74) Agent: **SCHOUTEN, Marcus, M.**; Prof. Holstlaan 6,
NL-5656 AA Eindhoven (NL).

(81) Designated States (unless otherwise indicated, for every
kind of national protection available): AE, AG, AL, AM,
AT, AU, AZ, BA, BB, BG, BR, BW, BY, BZ, CA, CH, CN,
CO, CR, CU, CZ, DE, DK, DM, DZ, EC, EE, EG, ES, FI,
GB, GD, GE, GH, GM, HR, HU, ID, IL, IN, IS, JP, KE,
KG, KP, KR, KZ, LC, LK, LR, LS, LT, LU, LV, MA, MD,
MG, MK, MN, MW, MX, MZ, NA, NI, NO, NZ, OM, PG,
PH, PL, PT, RO, RU, SC, SD, SE, SG, SK, SL, SY, TJ, TM,
TN, TR, TT, TZ, UA, UG, US, UZ, VC, VN, YU, ZA, ZM,
ZW.

(84) Designated States (unless otherwise indicated, for every
kind of regional protection available): ARIPO (BW, GH,
GM, KE, LS, MW, MZ, NA, SD, SL, SZ, TZ, UG, ZM,
ZW), Eurasian (AM, AZ, BY, KG, KZ, MD, RU, TJ, TM),
European (AT, BE, BG, CH, CY, CZ, DE, DK, EE, ES, FI,
FR, GB, GR, HU, IE, IT, LU, MC, NL, PL, PT, RO, SE, SI,
SK, TR), OAPI (BF, BJ, CF, CG, CI, CM, GA, GN, GQ,
GW, ML, MR, NE, SN, TD, TG).

Published:

— with international search report

For two-letter codes and other abbreviations, refer to the "Guidance Notes on Codes and Abbreviations" appearing at the beginning of each regular issue of the PCT Gazette.

(54) Title: FOLDABLE STAND

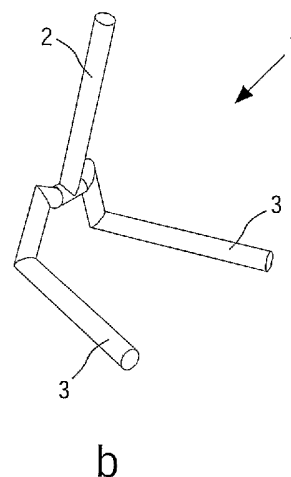
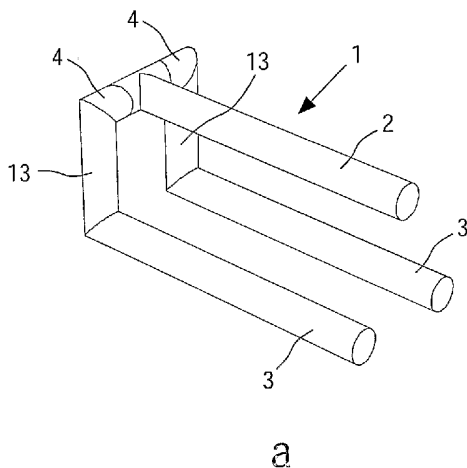

(57) Abstract: The invention relates to a foldable stand (1) comprising a longitudinally extending support (2) which is carried by two legs (3), each leg (3) being connected to the support (2) via a journal (4) having a central axis (5), said stand (1) being foldable between an operational position, in which the legs (3) extend in one plane and the support (2) extends away from said plane and a rest position in which the legs (3) extend in said plane and the support (2) also extends in said plane substantially parallel to the legs (3), wherein a housing (6) is provided to which the support (2) is fixedly mounted, and a coupling element (7) is provided in said housing (6) for rotationally coupling the central axes (5) of the journals (4) of the legs (3) at an angle relative to each other. Folding of the stand between the operational position and the rest position requires only one operation from a user. By moving the support from its operational position the legs are automatically taken along from said operational position into said rest position.

WO 2004/113783 A1

Foldable stand

The invention relates to a foldable stand comprising a longitudinally extending support which is carried by two legs, each leg being connected to the support via a journal having a central axis, said stand being foldable between an operational position in which the legs extend in one plane and the support extends away from said plane and a rest position in which the legs extend in said plane and the support also extends in said plane substantially parallel to the legs.

The invention further relates to an irradiation device for the human body comprising such a foldable stand.

10

A foldable stand of the type described in the opening paragraph is known from US 4,866,284. This known foldable stand is comprised in an irradiation device for irradiating the human body with ultraviolet radiation. The support is pivotally connected to a wide base for stable positioning of the device on a surface. Said base comprises a recess for receiving the support in the rest position, thus forming two legs. The support further carries a housing provided with an irradiation unit which is pivotally connected to the support. During operation, the legs support the device on the surface in a stable position by extending in one plane along the surface, and the support extends away from the surface. Ultraviolet radiation leaves the housing through a radiation emission window which extends in a horizontal plane. After use, the housing and the support are rotated into a rest position extending substantially parallel to the legs along the surface, the support being received in the recess between the legs. Although this known stand is relatively compact in the folded position, the stand is relatively complex to fold. This is cumbersome for the user.

25

It is an object of the invention to provide a foldable stand which is easily foldable. To achieve this object, a foldable stand according to the invention is characterized in that a housing is provided to which the support is fixedly mounted, and a coupling element is provided in said housing for rotationally coupling the central axes of the journals of the

legs at an angle relative to each other. In this manner, folding of the stand between the operational position and the rest position requires only one operation from a user. By moving the support from its operational position extending away from the plane into its rest position lying in the plane, the legs are automatically taken along from an operational position in the plane and enclosing an angle between them into a rest position in the plane and substantially parallel to each other. When the support is moved back again from the rest position into the operational position, the legs are automatically taken along from their position in the plane and substantially parallel to each other into their position in the plane and enclosing an angle between them. The foldable stand is thus easily foldable and user-friendly. Furthermore, the fact that the legs enclose an angle between them in the operational position ensures a stable position of the stand on the surface without the need for a heavy construction of the legs.

An embodiment of a foldable stand according to the invention is characterized in that each journal has a semi-cylindrical recess for cooperation with a semi-cylindrical protrusion provided on the coupling element by means of sliding and rotating surfaces. This offers a simple construction of the journals and the coupling element, because sliding and rotation is combined in one action so as to secure that the legs are moving simultaneously.

A further embodiment of a foldable stand according to the invention is characterized in that the coupling element has a central axis and comprises two cylindrical parts arranged in parallel and extending transversally to said central axis, the central axis of the coupling element intersecting a central axis of at least one journal at the center of at least one cylindrical part. In this manner the housing is less heavily loaded and the coupling element does not need a special bearing in the housing.

It is advantageous when the stand has elements for supporting the stand in a storage position with the legs and the support extending parallel to each other. Thus the compact foldable stand can be stored upright without the need of a wall or the like to support it.

It is furthermore advantageous when the central axes of the legs enclose an angle of 30° in the operational position.

A further embodiment of a foldable stand according to the invention is characterized in that the coupling element comprises a central coupling shaft provided with longitudinally extending grooves along its outer surface, and the two journals are provided with bevelled teeth for cooperation with said grooves. In this manner a solid and cost-effective construction is achieved.

A further embodiment of a foldable stand according to the invention is characterized in that the central axis of the central coupling shaft, the longitudinal axis passing through both teeth, and the central axis of a bearing carrying the journals intersect in one point. In this manner the parts only move rotationally with respect to each other during operation, which renders the construction more robust.

The invention further relates to an irradiation device for the human body comprising a foldable stand, characterized in that said foldable stand is a stand according to the invention.

The invention will be described in more detail hereinafter with reference to the drawings, in which

Figs. 1a and 2a show a schematic perspective view of a foldable stand according to the invention in a rest position and in an operational position, respectively, and Figs. 1b and 2b are plan views of said stand in a rest position and in an operational position, respectively,

Figs. 3a and b show a detail of a first embodiment of a foldable stand according to the invention,

Fig. 4 shows a detail of a second embodiment of a foldable stand according to the invention, and

Figs. 5a, b and c show details of a third embodiment of a foldable stand according to the invention.

Figure 1 shows different schematic views of a foldable stand 1 according to the invention, in a rest position (Figs. 1a, b) and an operational position (Figs. 2a,b). The foldable stand 1 comprises a longitudinally extending support 2 which is carried by two legs 3, each leg 3 being connected to the support 2 via a journal 4 having a central axis 5. A housing 6 is provided to which the support 2 is fixedly mounted, and a coupling element 7 is provided in said housing 6 for rotationally coupling the central axes 5 of the journals 4 of the legs 3 at an angle relative to each other. In this manner, the stand 1 can be folded by a user in only one operation between the operational position, in which the legs 3 extend in one plane and enclose an angle between them and the support 2 extends away from said plane and the rest position, in which the legs extend in said plane substantially parallel to each other and

the support also extends in said plane substantially parallel to the legs. The foldable stand can thus be folded in an easy and user-friendly manner.

Furthermore, the legs enclose an angle α between them in the operational position, while extending in said plane along a surface. Thus a stable position of the stand on a support surface is ensured while the legs have a relatively light construction. As can be seen in Figure 1a, this results in a compact foldable stand in its rest position which is easy to store. It is advantageous when the legs enclose an angle of 30° between them in the operational position.

In this embodiment, the stand has elements 13 for supporting the stand in a storage position with the legs and the support extending parallel to each other. This storage position may be, for example, the position of the stand in Figure 1a, rotated through 90° resting on elements 13 which then extend along the support surface. In this manner the folded stand can be easily stored away, for example in a closet or the like. These elements, but also the legs themselves, may be provided with wheels in order to make the folded stand easily movable in its rest position.

Figures 3a, b and c show a detail of a first embodiment of a foldable stand according to the invention. In this embodiment, each journal 4 has a semi-cylindrical recess 8 for cooperation with a semi-cylindrical protrusion 18 provided on the coupling element 7 by means of sliding surfaces 28 and rotating surfaces 38. In this embodiment, the rotating surfaces are provided as rounded edges 38 on the semi-cylindrical recesses 8 of the journals 4 which cooperate with the sliding surfaces 28, but these rounded surfaces may alternatively be provided as rounded edges on the semi-cylindrical protrusions 18 provided on the coupling element 7.

Figure 3b shows a position occurring during movement of the legs 3 in which the journals 4 slide over the cooperating sliding surfaces 28 and simultaneously rotate via the rotating surfaces 38. In this embodiment sliding and rotation is combined in one action, to ensure that the legs are moving simultaneously. This offers a simple construction of the journals and the coupling element.

Figure 4 shows a detail of a second embodiment of a foldable stand 1' according to the invention, in which the coupling element 7' has a central axis 75' and comprises two cylindrical parts 39 arranged in parallel and extending transversally to said central axis 75', the central axis 75' of the coupling element 7' intersecting a central axis 5' of at least one journal 4' at the center of at least one cylindrical part. For reasons of clarity, only one of the journals 4' is shown in the Figure. This construction is advantageous because it is

relatively simple, the housing is less heavily loaded, and the coupling element needs no bearings in the housing.

Figures 5a, b and c show details of a third embodiment of a foldable stand 1" according to the invention. Figure 5a is a top view of the housing 6" in which the coupling element 7" is provided for rotationally coupling the central axes 5" of the journals 4" of the legs 13" at an angle relative to each other. As can be seen in more detail in Figure 5b, the coupling element 7" comprises a central coupling shaft 71 provided with longitudinally extending grooves 72 along its outer surface, and the two journals 4" are provided with bevelled teeth 73 for cooperation with said grooves 72. For reasons of clarity, only one of the journals 4" is shown in the Figure. This construction is advantageous because it is solid and cost-effective.

Figure 5c shows a further detail of the third embodiment of a foldable stand 1" according to the invention, as enclosed by a broken-line square in Figure 5a. The central axis 75" of the central coupling shaft 71, the longitudinal axis 78 passing through both teeth 73, and the central axis 76 of a bearing 77 carrying the journal 4" intersect in one point. In this manner the parts only move rotationally with respect to each other during operation, which renders the construction more robust.

It is observed that the foldable stand according to the invention is especially suitable for use in an irradiation device for the human body. However, the foldable stand according to the invention is also suitable for use with other types of irradiation devices, or for supporting other elements such as, for example, a screen.

When the foldable stand according to the invention carries an element, it is noted that it is advantageous when the element carried by the stand is provided in a plane above the location of the legs in the operational position. Especially when the foldable stand according to the invention is used with an irradiation device for the human body, it is noted that it is advantageous when the housing with the irradiation unit is provided in a plane above the location of the legs in the operational position. When the user is lying on a bed during use of the irradiation device, the legs can thus be positioned under the bed during operation. In this manner the legs are not in the way and the space around the bed is left clear.

CLAIMS:

1. A foldable stand (1), comprising
 - a longitudinally extending support (2) which is carried by two legs (3), each leg (3) being connected to the support (2) via a journal (4) having a central axis (5),
 - said stand (1) being foldable between an operational position, in which the legs (3) extend in one plane the support (2) extends away from said plane,
 - 5 - and a rest position in which the legs (3) extend in said plane and the support (2) also extends in said plane substantially parallel to the legs (3),characterized in that
 - a housing (6) is provided to which the support (2) is fixedly mounted, and a coupling element
 - 10 (7) is provided in said housing (6) for rotationally coupling the central axes (5) of the journals (4) of the legs (3) at an angle relative to each other.

2. A foldable stand as claimed in claim 1, characterized in that each journal (4) has a semi-cylindrical recess (8) for cooperation with a semi-cylindrical protrusion (18) provided on the coupling element (7) by means of sliding and rotating surfaces (28, 38).
- 15

3. A foldable stand as claimed in claim 1, characterized in that the coupling element (7) has a central axis (75') and comprises two cylindrical parts (39) arranged in parallel and extending transversally to said central axis (75'), the central axis (75') of the coupling element (7) intersecting a central axis (5') of at least one journal (4') at the center of at least one cylindrical part (39).
- 20

4. A foldable stand as claimed in claim 1, characterized in that the stand (1) has elements (13) for supporting the stand (1) in a storage position with the legs (3) and the support (2) extending parallel to each other.
- 25

5. A foldable stand as claimed in claim 1, characterized that the central axes of the legs (3) enclose an angle of 30° in the operational position.

6. A foldable stand as claimed in claim 1, characterized in that the coupling element (7") comprises a central coupling shaft (71) provided with longitudinally extending grooves (72) along its outer surface, and the two journals (4") are provided with bevelled teeth (73) for cooperation with said grooves (72).

5

7. A foldable stand as claimed in claim 6, characterized in that the central axis (75") of the central coupling shaft (71), the longitudinal axis (78) passing through both teeth (73), and the central axis (76) of a bearing (77) carrying the journal (4") intersect in one point.

10

8. An irradiation device for the human body comprising a foldable stand, characterized in that the foldable stand is a stand according to any of the preceding claims.

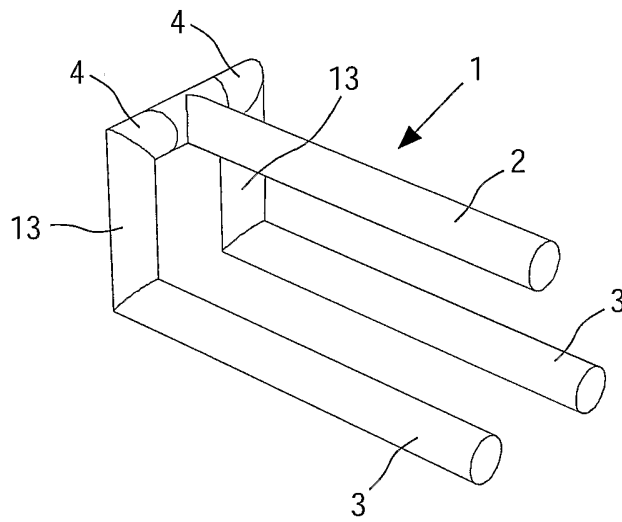

FIG. 1a

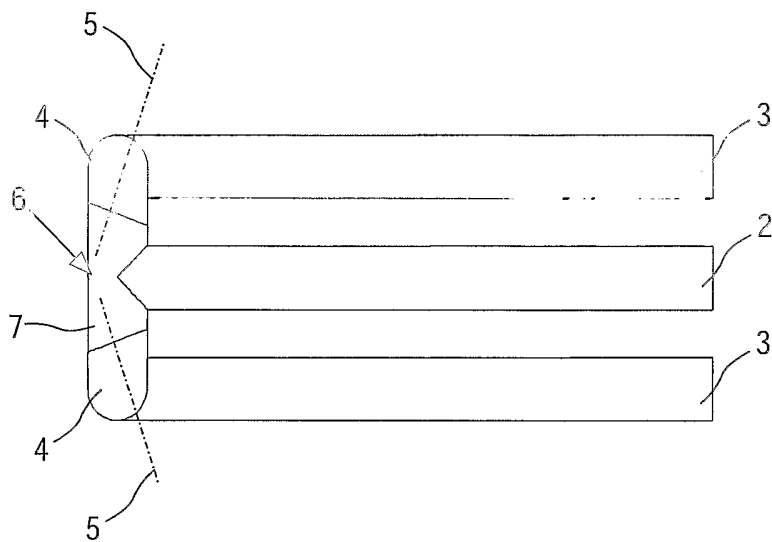

FIG. 1b

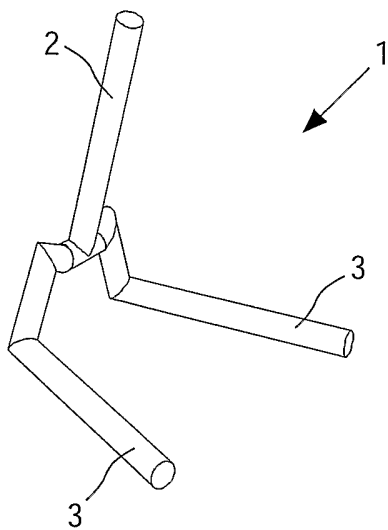

FIG. 2a

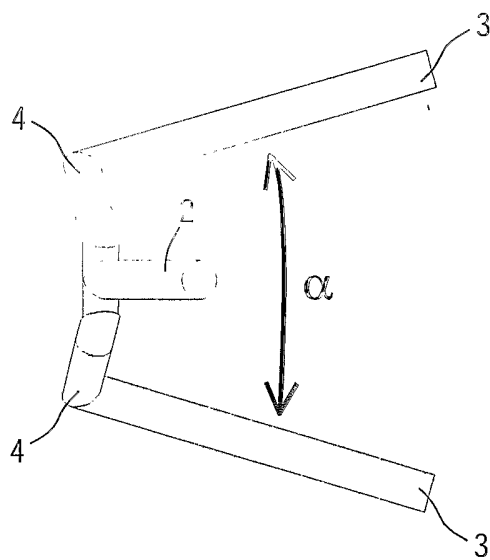

FIG. 2b

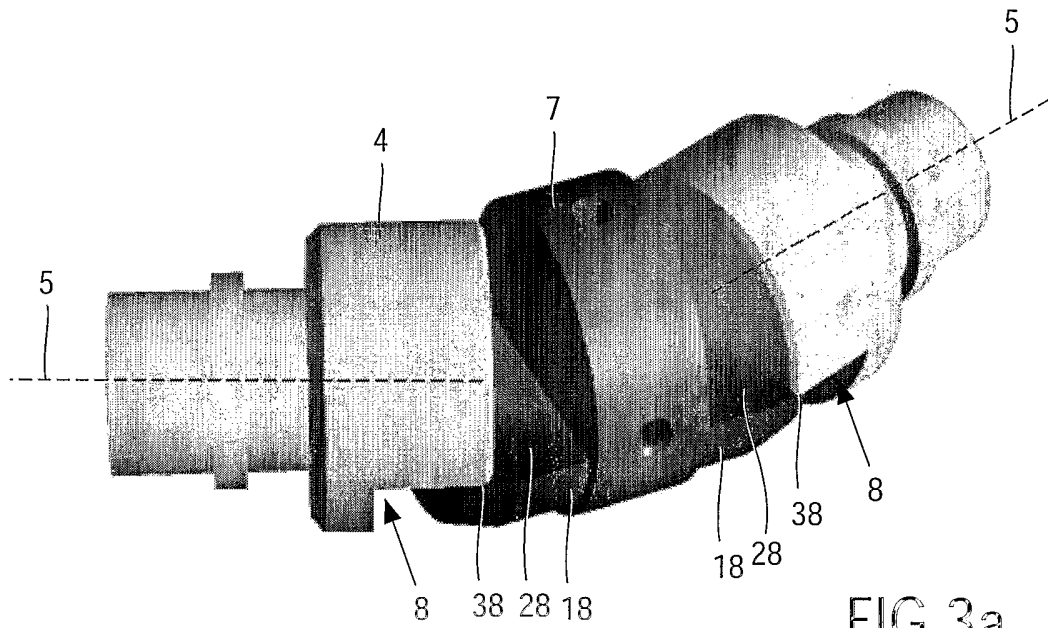

FIG. 3a

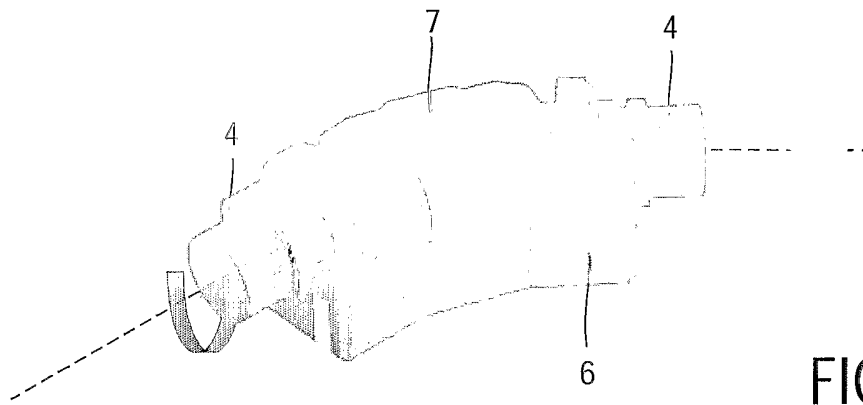

FIG. 3b

4/5

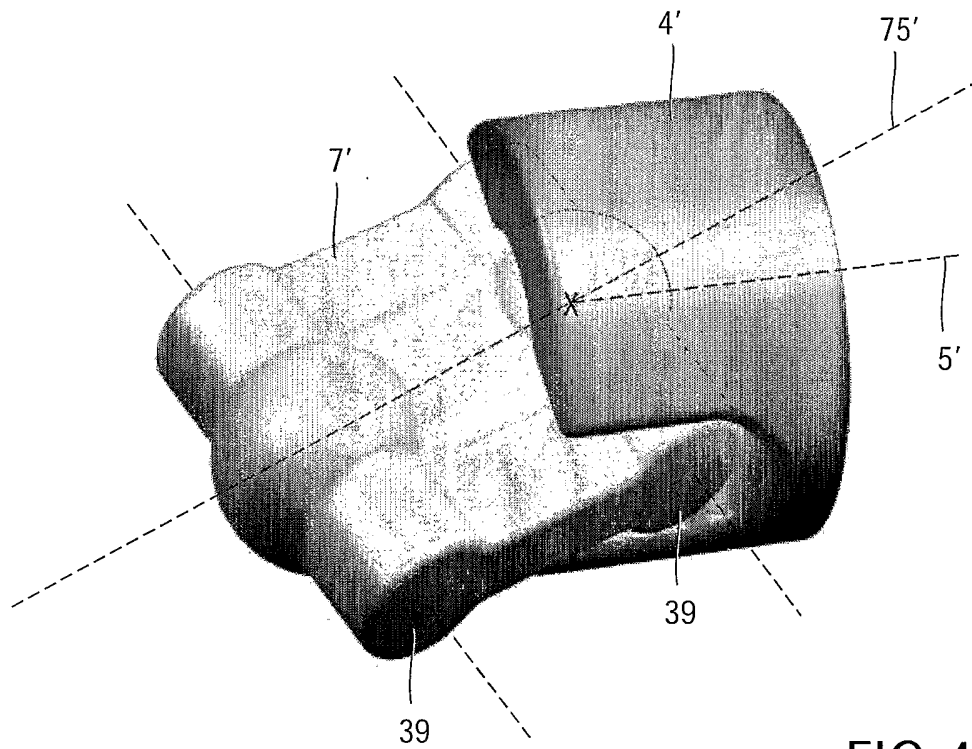

FIG.4

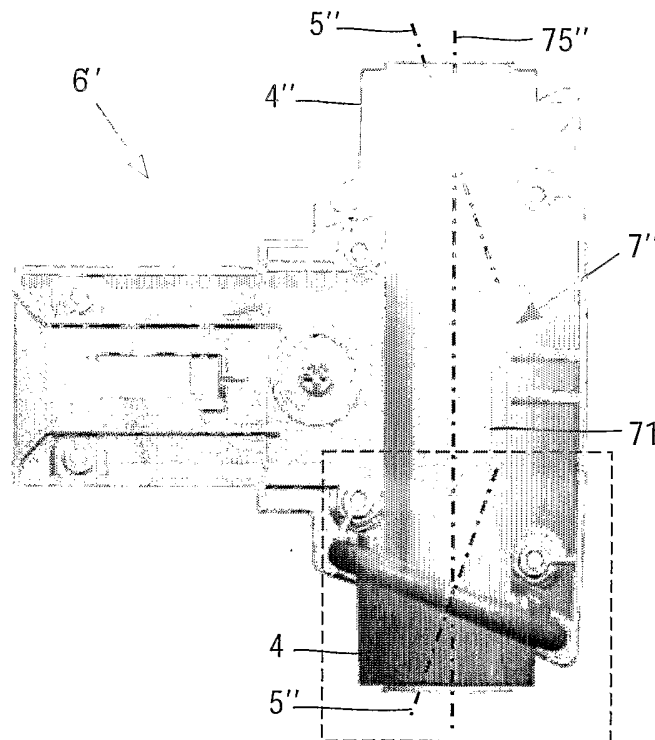

FIG.5a

5/5

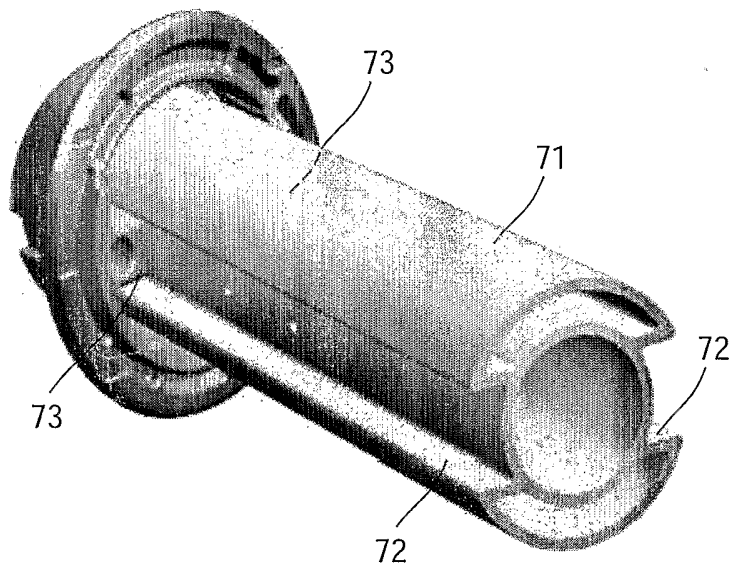

FIG. 5b

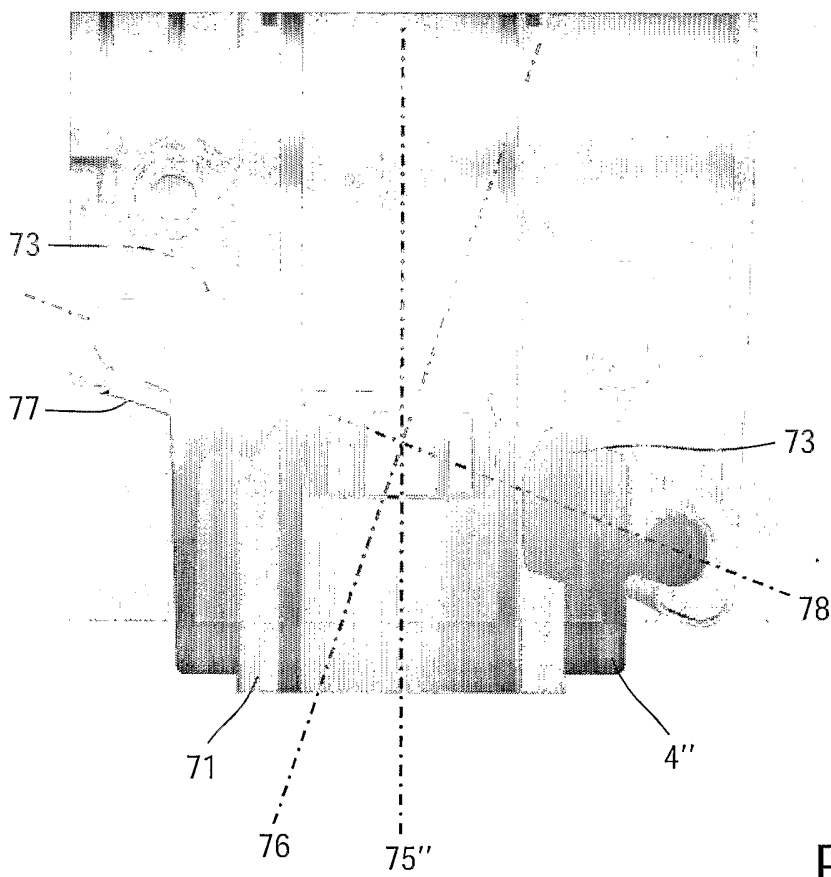

FIG. 5c

INTERNATIONAL SEARCH REPORT

International Application No
PC B2004/050963

A. CLASSIFICATION OF SUBJECT MATTER
IPC 7 F16M11/00 F16M11/16 A61N5/06

According to International Patent Classification (IPC) or to both national classification and IPC

B. FIELDS SEARCHED
Minimum documentation searched (classification system followed by classification symbols)
IPC 7 F16M A61N G10G A47K

Documentation searched other than minimum documentation to the extent that such documents are included in the fields searched

Electronic data base consulted during the international search (name of data base and, where practical, search terms used)
EPO-Internal

C. DOCUMENTS CONSIDERED TO BE RELEVANT

Category °	Citation of document, with indication, where appropriate, of the relevant passages	Relevant to claim No.
X	US 6 254 044 B1 (LEE LI-HWA) 3 July 2001 (2001-07-03)	1,4,5,8
Y	the whole document	2
X	US 5 197 701 A (OLSON MARK T) 30 March 1993 (1993-03-30) figures 1,2,4,8,10,11 column 2, line 25 - line 39 column 2, line 60 - column 3, line 13	1,4,5
Y	US 4 684 091 A (MORESCHI GIOVANNI) 4 August 1987 (1987-08-04) figure 7 column 4, line 42 - line 64	2
A	US 5 996 814 A (HOUSE KENNETH W ET AL) 7 December 1999 (1999-12-07) figures 1-10	1

Further documents are listed in the continuation of box C. Patent family members are listed in annex.

° Special categories of cited documents :

- *A* document defining the general state of the art which is not considered to be of particular relevance
- *E* earlier document but published on or after the international filing date
- *L* document which may throw doubts on priority claim(s) or which is cited to establish the publication date of another citation or other special reason (as specified)
- *O* document referring to an oral disclosure, use, exhibition or other means
- *P* document published prior to the international filing date but later than the priority date claimed
- *T* later document published after the international filing date or priority date and not in conflict with the application but cited to understand the principle or theory underlying the invention
- *X* document of particular relevance; the claimed invention cannot be considered novel or cannot be considered to involve an inventive step when the document is taken alone
- *Y* document of particular relevance; the claimed invention cannot be considered to involve an inventive step when the document is combined with one or more other such documents, such combination being obvious to a person skilled in the art.
- * & * document member of the same patent family

Date of the actual completion of the international search 28 September 2004	Date of mailing of the international search report 06/10/2004
---	---

Name and mailing address of the ISA European Patent Office, P.B. 5818 Patentlaan 2 NL - 2280 HV Rijswijk Tel. (+31-70) 340-2040, Tx. 31 651 epo nl, Fax: (+31-70) 340-3016	Authorized officer TERRIER DE LA CHAISE
--	---

INTERNATIONAL SEARCH REPORT

Information on patent family members

International Application No
PC B2004/050963

Patent document cited in search report	Publication date	Patent family member(s)	Publication date
US 6254044	B1	03-07-2001	NONE
US 5197701	A	30-03-1993	NONE
US 4684091	A	04-08-1987	NONE
US 5996814	A	07-12-1999	NONE