

Dec. 5, 1944.

H. F. WATERS

2,364,576

SIFT-PROOF PACKAGE AND SIDE SEAM THEREFOR

Filed Sept. 25, 1942

4 Sheets-Sheet 1

*Fig. 1*

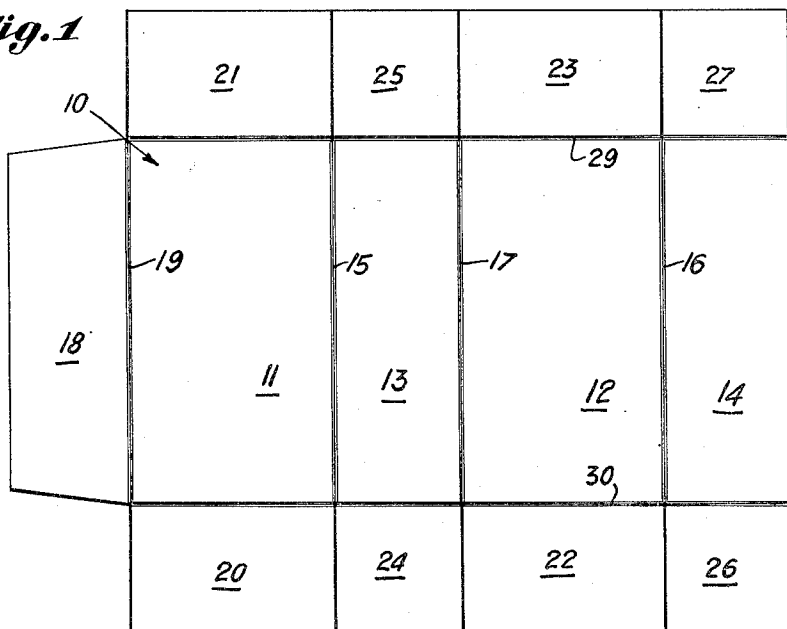

*Fig. 2*

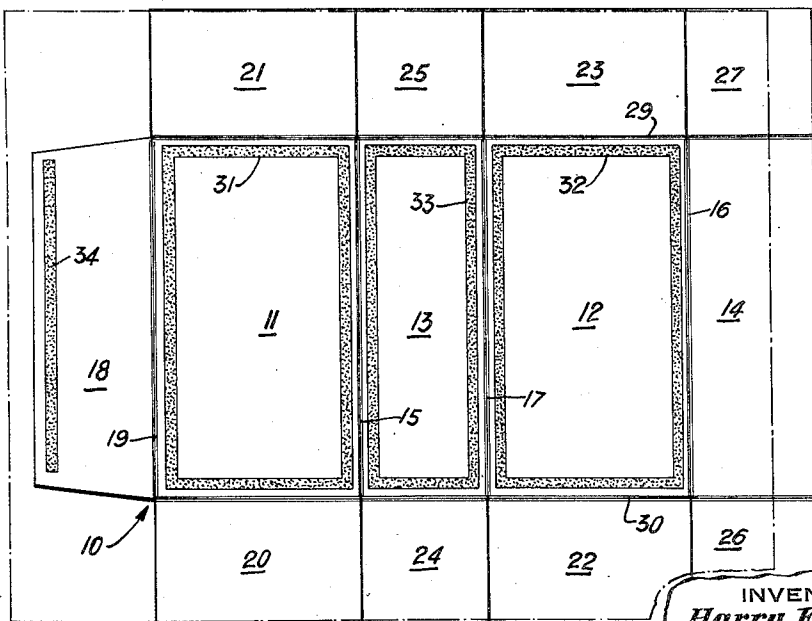

INVENTOR  
*Harry F. Waters,*

BY  
*Frederick A. Norton*  
ATTORNEY

Dec. 5, 1944.

H. F. WATERS

2,364,576

SIFT-PROOF PACKAGE AND SIDE SEAM THEREFOR

Filed Sept. 25, 1942

4 Sheets-Sheet 2

*Fig. 3*

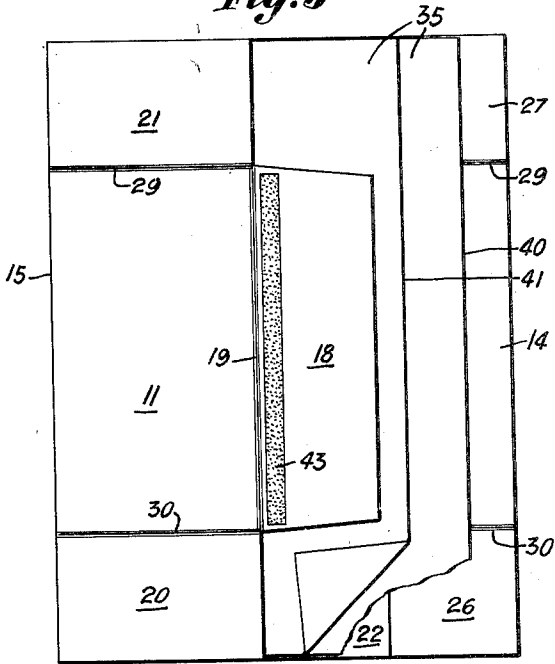

*Fig. 4*

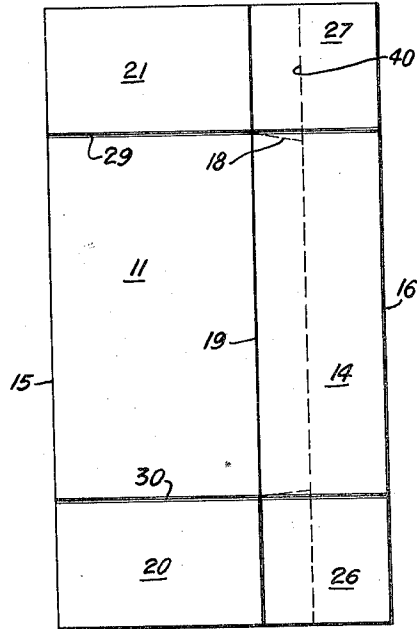

*Fig. 5*

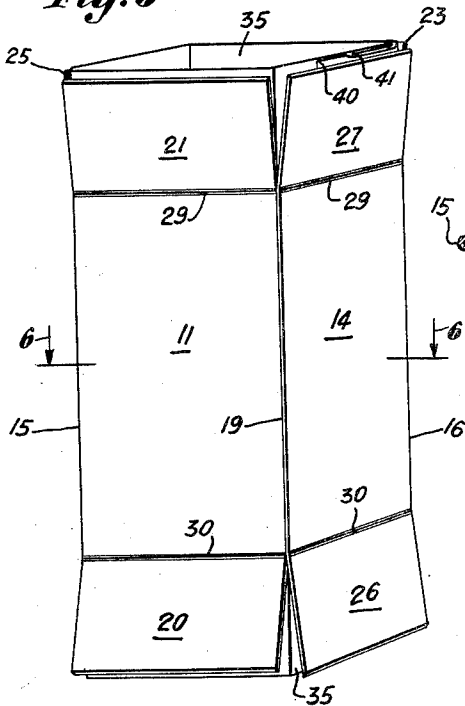

*Fig. 6*

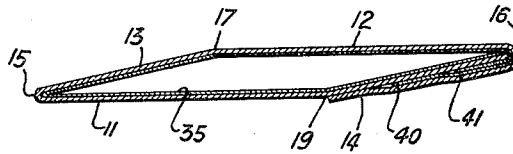

INVENTOR  
*Harry F. Waters,*  
BY  
*Frederick A. Norton*  
ATTORNEY

Dec. 5, 1944.

H. F. WATERS

2,364,576

SIFT-PROOF PACKAGE AND SIDE SEAM THEREFOR

Filed Sept. 25, 1942

4 Sheets-Sheet 3

*Fig. 7*

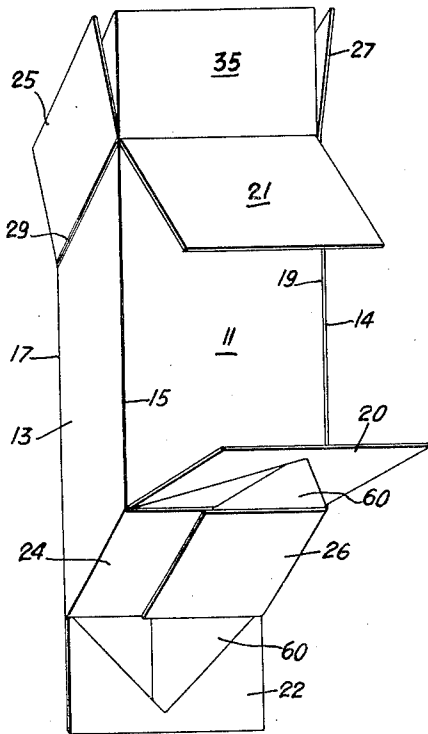

*Fig. 8*

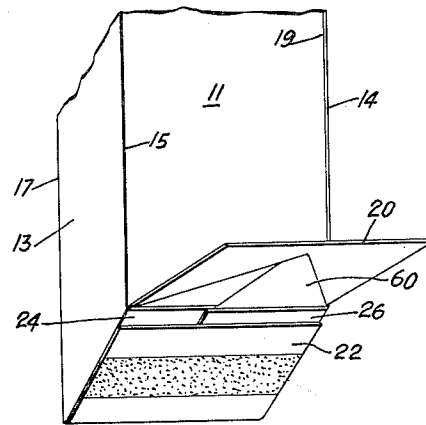

*Fig. 9*

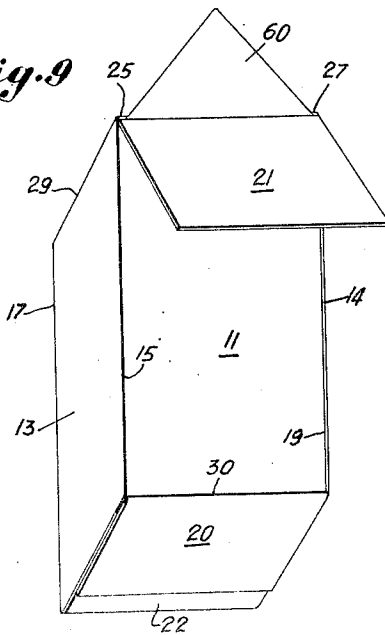

*Fig. 10*

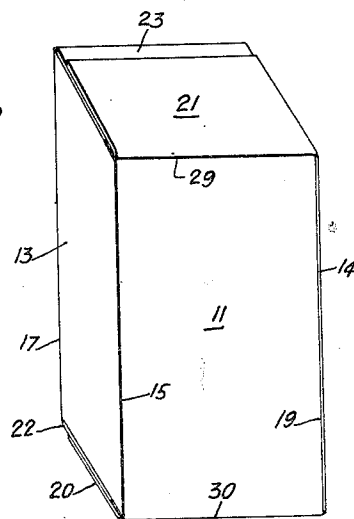

INVENTOR  
*Harry F. Waters,*  
BY  
*Frederick A. Norton*  
ATTORNEY

Dec. 5, 1944.

H. F. WATERS

2,364,576

SIFT-PROOF PACKAGE AND SIDE SEAM THEREFOR

Filed Sept. 25, 1942

4 Sheets-Sheet 4

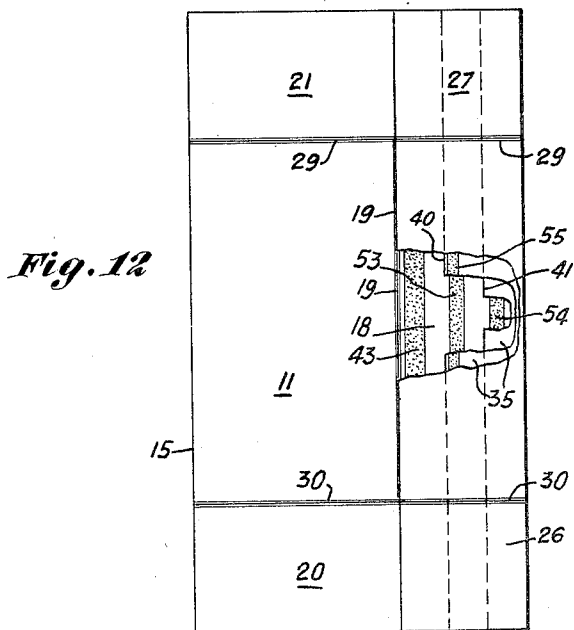
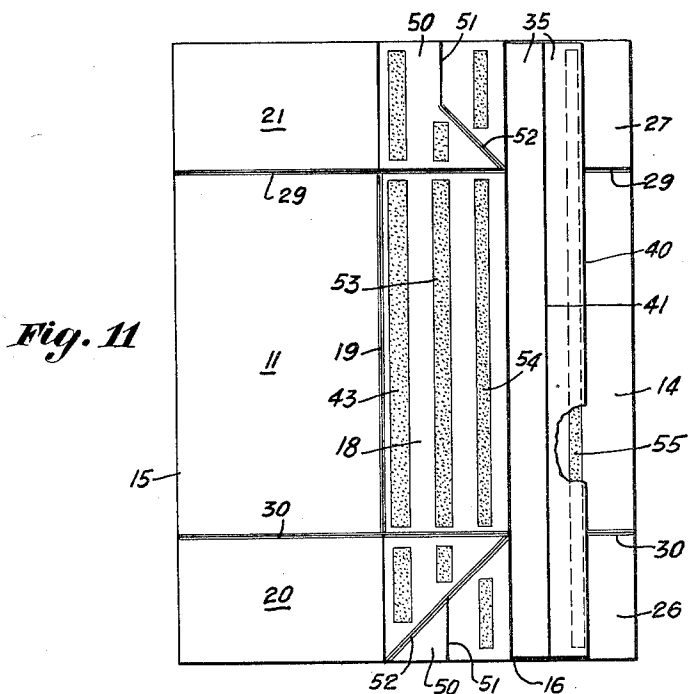

INVENTOR  
*Harry F. Waters,*  
BY  
*Frederick A. Norton*  
ATTORNEY

# UNITED STATES PATENT OFFICE

2,364,576

## SIFTPROOF PACKAGE AND SIDE SEAM THEREFOR

Harry F. Waters, New York, N. Y.

Application September 25, 1942, Serial No. 459,667

3 Claims. (Cl. 229-14)

This invention relates to containers, and more particularly to containers generally known as sift-proof containers, and especially adapted for the packaging of pulverant or granular materials.

Heretofore, difficulty was experienced with containers of this character, wherein pulverant and granular materials were packaged, in that the powdered material usually sifted out of the inner package, adjacent the opening, where the inner wrapper overlaps, and in so doing eventually sifted into and out of the surrounding carton, and thereby caused a substantial loss of the contents.

The present invention obviates these difficulties by the provision of a four-panel carton having a flexible liner adhesively secured therein, the marginal edges of the liner throughout the length of the carton being securely interposed and locked between one of the side walls and the locking panel of the carton, so that it is practically impossible for any pulverant material to sift through the seams of the inner package, throughout the length of the carton. To prevent sifting of the contents at the top and bottom ends of the carton, the liner sheet is foldably secured between the usual closure flaps, and the product is then securely maintained within the inner wrapper and cannot possibly sift out.

One of the main objects of the present invention is to provide or produce a carton like that above described, in large quantities, on the present type of standard, high-speed machinery and equipment, and without any material changes of equipment.

The novelty and method of making the present invention consists of a four-panel carton blank, die-cut on a high speed machine and having lines of adhesive rolled thereon, to accommodate a sheet of flexible material, which is used as a liner to enclose and package a powdered material. After the flexible sheet of material is properly secured to the blank, the composite sheet is then folded upon itself and sealed to form a lined tubular collapsible container. Before the container is filled the tubular carton is squared up and the open portion of the liner at the bottom of the carton, heat-sealed or not, may then be folded up between the closure flaps at the bottom of the carton. After the container is filled, the open mouth portion of the liner may or may not be heat-sealed and the flaps are then closed with the liner similar to the way the bottom is closed.

Other objects and advantages of the present invention will be brought out in the following

specification and claims. Reference will be had to the accompanying drawings forming a part of this specification in which similar reference characters indicate corresponding parts throughout the several views, in which,

Fig. 1 is a plan view of a four-panel carton blank;

Fig. 2 is a similar view to Fig. 1 showing a flexible liner overlying the blank, and secured to the carton by the adhesive lines shown thereon;

Fig. 3 shows the carton folded upon itself along a longitudinal fold line;

Fig. 4 shows the completed tube;

Fig. 5 is a perspective view showing the tube of Fig. 4 in squared-up position;

Fig. 6 is an enlarged cross section taken on the line 6-6 of Fig. 5;

Fig. 7 is a perspective view showing the carton viewed from the bottom, and with the bottom flaps open;

Figs. 8 and 9 are views similar to Fig. 7;

Fig. 10 is a perspective view of a completed package;

Fig. 11 is a modified form of carton partially folded, and

Fig. 12 is a plan view of the carton of Fig. 11 completely folded.

Referring to the drawings, there is shown a cut and scored carton blank 10, comprising a pair of main wall panels 11 and 12, hingedly connected by score lines 15, 16 and 17 to a pair of side wall panels 13 and 14, and a locking panel 18 hingedly secured to the main panel 11 by a score line 19.

The main panels 11 and 12 and side panels 13 and 14 have the usual closure flaps 20, 21, 22, 23, 24, 25, 26 and 27 hingedly secured thereto by transverse score lines 29 and 30.

The paperboard blank 10 is provided with lines of adhesive 31, 32 and 33 entirely surrounding the marginal edges of the main wall panels 11 and 12 and the side wall panel 13, and a line of adhesive 34 is rolled on the locking panel 18 adjacent the outer edge thereof.

A sheet of flexible lining material 35 as shown in dot and dash lines in Fig. 2 is properly positioned on the blank 10, so that the adhesive lines will hold the sheet 35 in the desired position for folding.

As shown in Fig. 3, the carton 10 and flexible sheet 35 are folded upon themselves so that the longitudinal marginal edges 40 and 41 of the sheet 35 will contact face-to-face, with the edge 40 extending beyond the edge 41, as will be hereinafter described. The side wall panel 14 is then folded on score line 16 over and on the locking

panel 18 and adhesively secured thereto by a line of adhesive 43 on the locking panel 18. When the side wall panel 14 is folded on the score line 16 it will also fold the two edges 40 and 41 of the sheet 35 with it and place the two edges on top of the locking panel 18. Since the side wall panel is thereby secured to the locking panel 18, the edges 40 and 41 of the liner sheet will be interposed and locked between the side wall panel 14 and the locking panel 18.

Referring to the enlarged section in Fig. 6, it will be seen that the edge 40 of the sheet 35 extends beyond the edge 41 and has both sides thereof in contact with the two panel walls, whereas the edge 41 has only one side contacting with one panel wall. This structure doubly secures at least one edge of the sheet and affords a tight bind of the liner against slippage, which might happen if the edges were in registry with each other. The joint at the score line 16 provides a very tight seal and will insure against any sifting of the contents into the outer carton throughout the length of the score line 16.

To insure against sifting at the top and bottom of the carton, the sheet may or may not be heat-sealed and folded in a symmetrical manner with the ears 60 folded and sealed between the top closure flaps in the usual manner. This affords a tight, sift-proof seal throughout the entire carton.

The modification shown in Figs. 11 and 12 is substantially the same as the preferred form with the exception that the locking panel 18 has extension flaps 50 in each end thereof with medial slots 51 half way in from the end to meet a diagonal score line 52. The panel 18 is provided with a plurality of lines of adhesive 43, 53 and 54 thereon to receive the edges 40 and 41 of the liner 35 and also the outer edge of the side wall panel 14 thereon. When the side wall panel 14 is folded on the score line 16, the edge 41 of the liner 35 will adhere to the adhesive line 54, the edge 40 of the liner 35 will adhere to the line 53 and the outer edge of the panel 14 will adhere to the adhesive line 43. The edge

40 of the liner 35 is adhered to the side wall panel 14 by a line of adhesive 55 running the full length of the side panel wall so that when the side panel wall 14 is folded over upon the panel 18 as shown in Fig. 12 the two edges 40 and 41 of the liner 35 are adhesively held between the panel wall 14 and the locking panel 18. The purpose of scoring the flaps 50, as shown at 52, and also the provision of the slots 51 is to permit the open ends of the tube to be properly heat-sealed across the mouth thereof if desired, and the score lines 52 facilitate the closing of the flaps 50 together with the liner 35. The reference characters used for the figures shown in the preferred form are also used for corresponding parts in Figs. 11 and 12.

It will be understood that the present invention has been designed to be adapted to the present type of high-speed machinery to produce a four-panel carton and liner, as described, but many modifications may be made if desirable, without departing from the principle of the locking feature as shown and described.

I claim:

1. A flat-folded lined carton comprising a four-panel carton blank having a locking panel, a pair of main panels and a pair of side panels, a flexible sheet of material adhesively secured to said blank in the main panel areas, said blank and said flexible sheet being cofolded so that the free marginal edges of said sheet parallel with the common fold line will extend over the edge of said locking panel and unsecured thereto, the locking panel and cooperating side panel being secured together at the edge of the side panel leaving the interposed edge layers of the liner free to move upon movement of the carton blank.

2. Package construction according to claim 1 in which the free edges of the liner overlap.

3. Package construction according to claim 1 in which one of the marginal edges is secured to the blank and the other rides free.

HARRY F. WATERS.