

(19)



Europäisches Patentamt  
European Patent Office  
Office européen des brevets



(11)

**EP 0 753 396 B2**

(12)

**NEW EUROPEAN PATENT SPECIFICATION**

(45) Date of publication and mention  
of the opposition decision:  
**01.03.2006 Bulletin 2006/09**

(51) Int Cl.:  
**B30B 15/06<sup>(2006.01)</sup> B30B 15/02<sup>(2006.01)</sup>**

(45) Mention of the grant of the patent:  
**19.12.2001 Bulletin 2001/51**

(21) Application number: **96111231.5**

(22) Date of filing: **12.07.1996**

(54) **Device suitable to be used with a pressing apparatus**

Vorrichtung geeignet zur Anwendung in einem Pressgerät

Dispositif utilisable dans un appareil de pressage

(84) Designated Contracting States:  
**DE ES IT**

(30) Priority: **14.07.1995 IT MI951519**

(43) Date of publication of application:  
**15.01.1997 Bulletin 1997/03**

(73) Proprietor: **S.I.T.I. S.p.A. Società Impianti  
Termoelettrici Industriali  
28040 Marano Ticino (Novara) (IT)**

(72) Inventors:  
• **Bossetti, Renato  
28100 Novara (IT)**  
• **Walchhutter, Ulrico  
20133 Milano (IT)**

(74) Representative: **Forattini, Amelia et al  
c/o Internazionale Brevetti  
Ingg. ZINI, MARANESI & C. S.r.l.  
Piazza Castello 1  
20121 Milano (IT)**

(56) References cited:  
**EP-A- 0 035 568 EP-A- 0 241 933  
EP-A- 0 402 800 EP-A- 0 493 095  
EP-A- 0 547 305 DE-A- 4 326 365  
DE-A- 4 343 336 DE-A- 4 425 565  
DE-DE- 3 926 854 DE-U- 9 203 546  
FR-A- 2 288 569 GB-A- 2 019 277**

• **Stampo multiplo universale (drawing)**

**EP 0 753 396 B2**

## Description

**[0001]** The present invention relates to a pressing device for use in a pressing apparatus for the dry pressing of granular or powdery material. The molded objects can be for example tiles, dishes, refractory bricks, et cetera. The invention furthermore relates to a pressing apparatus that includes the device.

**[0002]** A pressing apparatus that includes the device according to the invention has in particular: a main structure for containing the pressing force, which is generally annular; actuator devices for performing pressing by virtue of the descent of an upper mold; loading devices for loading the material to be molded into a lower mold; and levelling devices for levelling the upper surface of the material loaded in the lower mold. The loading and levelling devices are generally formed by a single device, termed carriage, that includes a grid that can slide on the mold for loading and a front end that performs levelling during the return stroke. For a more detailed description of the pressing apparatus, reference is made to the PCT patent application no. WO 89/11969 in the name of the same Applicant.

**[0003]** The device according to the invention is in particular of the type that includes: a bed plate for withstanding a pressing force that is discharged onto a lower mold; a base plate that is arranged above the bed plate to support the template of the lower mold; a strike plate that is arranged above the base plate so as to support a lower plunger of the lower mold; pusher pistons for raising the strike plate; pusher cylinders for the pusher pistons, which are rigidly connected to the bed plate; a flow splitter for distributing the same flow to each one of the pusher cylinders, so that the strike plate can be moved vertically, parallel to itself, by virtue of passages of flow through the flow splitter.

**[0004]** The term "bed plate" commonly references a body that is thick enough to absorb the pressing force without permanent deformations. The bed plate is normally installed below all the molding devices, directly in contact with the pressing apparatus and in particular with the structure for containing the pressing forces.

**[0005]** The term "base plate" references a plate that remains fixed to the bed plate during all pressing cycles and is removed only when the mold is changed. By supporting the template and the strike plate, the base plate allows to remove in a single operation the entire set of lower molds without substantially modifying the relative positions of the various components.

**[0006]** The term "strike plate" commonly references a plate that can move vertically and supports the lower plungers, so that the plungers can be moved to perform the loading and mold extraction operations. During pressing, the strike plate remains motionless in the lower position of its vertical stroke, so that the pressing force absorbed by the strike plate can be discharged onto the bed plate.

**[0007]** To extract the molded part, the strike plate rises

until the top of the lower plunger reaches the level of the template, so that the carriage can push the molded part forward. Once mold extraction has ended, the strike plate does not descend to the bottom of its stroke but stops at a certain intermediate level, so that it is possible to load the lower mold with a preset amount of material, according to the position in which the strike plate has stopped. Obviously, the precision of the positioning of the strike plate in this step is decisive to determine the amount of powder that is loaded in the various parts of the mold and therefore to ensure a satisfactory final result. For a more detailed description of the loading and mold extraction operations, reference is made to European patent application no. 0 547 305 in the name of the same Applicant.

**[0008]** The pusher piston-and-cylinder units for lifting the strike plate with respect to the bed plate are generally four and are arranged at the four corners of the strike plate. They allow to effectively control parallelism between the strike plate and the bed plate, since they are all fed by identical flows generated by a flow splitter. For a more detailed description of these units, reference is made to European patent application no. 0 547 305 in the name of the same Applicant.

**[0009]** The term "flow splitter" references a device that is capable of generating multiple flows that are all identical to each other. However, it is evident that an equivalent but far less practical arrangement could be to use a flow splitter that generates mutually different flows and piston-and-cylinder units that have proportionally different cross-sections. Preferably, a flow splitter is provided so as to receive a single liquid flow as feed and split this flow into a plurality of output flows that are all identical to one another. A flow splitter is generally shown schematically by virtue of a plurality of positive-displacement pumps whose axes are all mechanically connected to each other, so that all the pumps must rotate at the same speed.

**[0010]** It is also evident that an equivalent flow splitter can be arranged providing a distinct proportional valve and a distinct encoder for controlling the movements of the actuation means commanded by each flow, so that all the flows will be the same because each proportional valve can be adjusted in order that all encoders move synchronously. In other words the proportional valves can be adjusted so that all provide substantially the same flow independently from the stress occurred to each actuation means, i.e. independently from the pressure of each flow.

**[0011]** A preferred embodiment of a flow splitter includes a separate feeder piston for each one of the pusher piston-and-cylinder units. The feeder pistons are mechanically and rigidly connected to each other, and each one is contained in a separate feeder cylinder. The feeder cylinders are mechanically and rigidly connected to each other. More preferably, the feeder pistons are hollow, so that the pusher pistons are fed by virtue of the cavities. For a more detailed description of a flow splitter, reference is made to European patent application no. 0 547

305 in the name of the same Applicant and in particular to Figure 15.

**[0012]** The above is, in summary, the main field of industrial utilization of the invention, but this field is not a limitation of the invention's scope, since the device and the apparatus according to the invention, in particular as described and claimed hereinafter, can be advantageously used in any other equivalent field, as claimed in the accompanying claims.

**[0013]** Devices of this type are known and are described for example in European patent application no. 0 547 305 in the name of the same Applicant and in Italian patent application no. MI94A001082, which was filed earlier but published after the priority date of the present application, also in the name of the same Applicant. However, it has been observed that these known devices have some drawbacks. In particular, in certain conditions, with the device according to the cited European patent application, seizures of the pusher piston-and-cylinder units have been observed, with deformations of the seats, after which hydraulic tightness is compromised. Furthermore, with both of the above mentioned devices it is not possible to install conventional molds, in the form in which they are already largely used, but it is necessary to modify them, particularly by using only the lower plungers. However, in this manner the molds are no longer perfectly interchangeable with conventional-type presses that do not use flow splitters. Furthermore, in both of the above mentioned devices the air bubbles that are accidentally present in the oil are eliminated with a vent that eliminates air and oil together. However, it has been observed that this system does not allow to eliminate all the air that is present in the circuit, especially in the initial step of operation. Furthermore, it has been found that during transport, assembly, or maintenance the pusher pistons tend to fully exit from their cylinders. A tank pressurization of approximately 3 bar is in fact sufficient for the extraction of the pistons. Furthermore, all operations for replacing gaskets, replacing scored pistons, et cetera must be performed on the spot, and this leads to various problems: first of all, the production unit remains idle for a very long time, with a financial damage that is always very high because it is necessary to stop the entire downstream line, the kilns, et cetera; furthermore, the maintenance work is performed in a department which, since it deals with the pressing of powders, is generally dusty and therefore unsuitable for mechanical machining; moreover, the mechanical equipment required for this type of intervention is generally not available on the spot.

**[0014]** Conventional-type presses use two long rods that are mechanically connected to each other from below, are actuated from below, and support in a cantilevered fashion the vertical movement of the strike plate and of the lower plungers both during ascent and during descent. Since the movement of the lower plungers can jam due to friction or seizures between the lower plungers and the template, a consequence of this is that in these cases the rods are highly stressed, so that the guiding

bushes of the rods wear out and after a short time the consequent plays produce considerable inaccuracies in loading the powder in the lower mold. In order to move the rods from below, it is necessary to have a so-called "pit", that is to say, a floor recess that allows access to the devices that move the rods. The movement of the rods is of two kinds: a vertical one, so as to move the strike plate vertically, and a rotary one, so as to turn the rods about their own axis in order to disengage the strike plate during mold changing. Engagement and disengagement of the strike plate generally occur with a dovetail or T-shaped coupling, which tends to wear out with use, especially at the corners. The fact that the rod movement devices are arranged in the pit entails evident problems for all tuning and maintenance work. It is not possible to check operation, but the entire unit must be disassembled from below.

**[0015]** The conventional-type presses described above, in addition to the long-standing problems related to inaccuracies in powder loading, have difficulties in changing the molds due to centering and positioning problems. It is furthermore necessary to provide additional pistons merely to allow to lift the base plate and thus change the molds.

**[0016]** The aim of the present invention is therefore to overcome the above drawbacks with pressing device according to claim 1. This aim is achieved by means of the features of Claim 1. The structural and functional characteristics of the invention and its advantages with respect to the known art will become apparent from the following description of the invention, with reference to the accompanying drawings, wherein:

Figure 1 is a partially sectional front view of the device according to the invention;

Figure 2 is a plan view of the device according to the invention;

Figure 3 is a partially sectional side view of the device according to the invention;

Figure 4 is a front sectional view of a detail of Figure 1;

Figure 5 is a front sectional view of a second embodiment of a detail of Figure 1;

Figure 6 is a schematic view of the device and of the hydraulic circuit;

Figure 7 is a sectional front view of a detail of the device of Figure 1;

Figure 8 is a plan view of a detail of the device of Figure 7; and

Figure 9 is a plan view of the detail of Figure 8 in a

second operating position.

**[0017]** With reference to Figures 1 to 9, the device according to the invention includes a bed plate 10 for withstanding a pressing force that is discharged onto a lower mold 11. In particular, the lower mold 11 is formed laterally by the template 12 and on the bottom by the lower plungers 13. A base plate 14 is arranged above the bed plate 10 and supports the template 12 by virtue of the pistons 15. The base plate 14 is removable, so that by removing the base plate 14 it is also possible to remove the parts that are located above and particularly the strike plate 16 and the lower mold 11. The base plate 14 can be fixed to the bed plate by virtue of the screws 17, so that the base plate 14 remains fixed to the bed plate 10 during each pressing cycle but can be removed for mold changing.

**[0018]** The strike plate 16 supports the plungers 13 of the lower mold 11. Generally, the plungers 13 are rigidly coupled to the strike plate magnetically.

**[0019]** The pusher pistons 18 have the task of lifting the strike plate 16. The pistons 18 are contained in cylinders 19, which are rigidly connected to the bed plate 10. In particular, the cylinders 19 are contained in holes 20 that are formed in the bed plate 10.

**[0020]** The strike plate 16 is supported by the pusher pistons 18 by virtue of a simple support coupling 21. In this manner it is possible to allow free accidental movement of the strike plate 16 in a direction that is not parallel to the bed plate 10. This can occur, for example, as a consequence of a jamming that blocks the mutual sliding of the lower plungers and of the template or due to the presence of air bubbles in the oil, et cetera.

**[0021]** The length of the pusher pistons 18 is such as to allow to lower the top 22 of the pistons 18 to a level that is not higher than the upper surface 23 of the bed plate 10. In other words, the pistons 18 can retract fully into the bed plate 10.

**[0022]** The support coupling 21 is provided by virtue of an extension 24 of the strike plate 16 through the base plate 14. For this purpose, the base plate 14 has openings 25 to allow the passage of the extensions 24. Each extension 24 is fixed in a seat 26 that is provided in the strike plate 16. The coupling between the extension 24 and the seat 26 has a certain play, so as to allow a certain free horizontal movement between the extension 24 and the seat 26 before the tightening of the bolt 9 from above. Rotation of the extension 24 is prevented by the pin 8. In this manner it is possible to automatically adjust the horizontal position of the extensions 24. The bolts 9 are in fact tightened after resting the strike plate on the pusher pistons 18, so that the extensions 24 are automatically arranged in the correct position.

**[0023]** The support coupling 21 is of the self-centering type, and this characteristic is provided by virtue of the coupling of a concave profile 27 with a convex profile 22. In particular, preferably, the concave profile is rigidly coupled to the strike plate 16 and the convex profile 22 is

rigidly coupled to the top of the pistons 18. More preferably, the convex profile 22 is spherical and the concave profile 27 is conical or spherical. The concave profile 27 and/or the convex profile 22 are formed with an insert made of hard material that is rigidly coupled to the strike plate 16 and/or to the piston 18 by virtue of a forced coupling. With particular reference to Figure 4, the insert is inserted inside the piston 18; with particular reference to Figure 5, the insert is fitted externally, on the top of the piston 18. In all cases, the forced coupling can be provided by hot keying.

**[0024]** Each cylinder-and-piston unit has an upper chamber 28 and a lower chamber 29. The lower chamber 29 of each unit is fed by the flow splitter 30, which in the schematic illustration of Figure 6 is actuated by the piston 31 and produces four identical flows by virtue of the four pistons 32.

**[0025]** A suction device 33 can be connected to each upper chamber 28 of the cylinder-and-piston units, so as to draw gas from the lower chamber 29, through the gasket 34. The suction device 33 is preferably a Venturi device. The suction device 33 is connected to the upper chambers 28 of the pusher cylinders 19 by virtue of a valve 35 that is capable of cutting off the suction device 33 and of sending pressurized air to the upper chambers 28. Preferably, the suction device 33 is connected to the upper chambers 28 by virtue of a decanting device 36 to decant aspirated oil traces from the upper chambers.

**[0026]** The encoder 6 detects a position of the flow divider 30 and consequently detects a position of the strike plate 16. It is so possible to adjust a proportional valve 7 according to the position signal detected by encoder 6.

**[0027]** Each one of the cylinders 19 is accommodated in the bed plate 10 by virtue of a hole 20 that is formed in the bed plate 10. Each cylinder 19 has an upper abutment 37 that is arranged so that each one of the pistons 18 can pass through a hole 38 of the abutment 37.

**[0028]** The coupling between the cylinders 19 and the holes 20 of the bed plate 10 is performed by virtue of complementary abutments: each cylinder 19 has an external abutment 39 that is suitable to engage a complementary abutment that is formed on the bed plate 10. In particular, the external abutment 39 is a wider region of the upper part of the cylinder 19, whereas the complementary abutment is a wider region of an upper part of the hole 20 in the bed plate 10.

**[0029]** With particular reference to the embodiment of Figure 5, the cylinder 19 is fixed to the bed plate 10, inside the hole 20, by virtue of a first threaded part 40 that engages the wider region 39 formed in the upper part of the cylinders 19. The abutment 27 is formed by a removable flange 41. The thickness of the cylinder 19 is, in this case, sufficient to allow to fix the flange 41 on the cylinder 19 by virtue of a second threaded part 42 that passes through the flange 41 and is screwed in a thread that is formed in the cylinder 19.

**[0030]** With reference to Figures 1 to 9, the upper sur-

face 43 of the abutment and/or of the bolts 42 is at a level that is not higher than the upper surface 23 of the bed plate 10.

**[0031]** The cylinders 19 are provided with the abutment 37, which has already been fixed, and are inserted in the bed plate 10 from above. The unit formed by the cylinder 19 and by the piston 18 is of the double-acting type, so as to act by virtue of the upper chamber 28 and the lower chamber 29. In this manner, each unit 18 and 19 can be assembled and tested in the workshop prior to installation. Accordingly, upon installation it is sufficient to insert the unit in the bed plate 10.

**[0032]** The side wall of the cylinder 19 has a substantially vertical first hole 44 combined with a substantially horizontal hole 45, in order to feed the upper chamber 28 from below, preferably with a gas, generally air. The lower wall of the cylinder 19 has a second substantially vertical hole 46 for feeding the lower chamber 29 with a liquid, generally oil, from below.

**[0033]** A traction cylinder 47 is rigidly connected to the bed plate 10 by virtue of the screws 48. A traction piston 49 is inserted in the traction cylinder 47 and has traction devices 50 to engage the strike plate 16 by traction and disengage it on command. The traction devices 50 preferably include a rotating part 51 with an enlarged top, so that a first rotation angle of the rotating part 51 allows to engage the strike plate 16, as shown with particular reference to Figure 8, and so that a second rotation angle allows to disengage the strike plate 16, as shown with particular reference to Figure 9. In particular, the first rotation angle and the second rotation angle are displaced by 90° with respect to each other. The enlarged end 51 has a hemispherical shape that is truncated on two opposite sides 52 and 53. The rotating part 51 includes a rod 54 that has a square cross-section and passes through the body of the traction piston 49. The rod 54 is actuated from below by virtue of an actuator device 55 that is a hydraulic rotary actuator with limited rotation.

**[0034]** The traction cylinder-and-piston unit is of the double-acting type and has an upper chamber 56 that is fed with a liquid and a lower chamber 57 that is fed with a fluid at a lower pressure, preferably constituted by air.

**[0035]** Preferably, the cover 58 is formed so as to be monolithic with the strike plate 16 and the seat of the traction devices 50 is machined on the strike plate 16 from below. In this manner, the ability of the strike plate 16 to support the lower plungers is greater.

**[0036]** The method for replacing the molds is as follows:

During step a), the traction devices 50 are disengaged. The traction piston 49 rises, by virtue of the injection of air into the lower chamber 57, the enlarged end 51 of the traction devices 50 rotates by virtue of the rotation of the hydraulic rotary actuator 55 and of the rod 54, and the traction piston 49 descends until it fully retracts into the bed plate 10 by feeding oil into the upper chamber 56.

During step b), the pusher pistons 18 are raised. The locking screws 17 that connect the base plate 14 to the bed plate 10 loosen, and a spacer, not shown, is interposed between the strike plate 16 and the template 12, so that the lifting of the template 12 automatically also entails the lifting of the base plate 14. Then liquid is loaded into the lower chambers 29 of the pusher pistons 18 and air is discharged from the upper chambers 28.

During step c), the lower mold 12, 13, 14, 15, and 16 is replaced with another one. Transfer devices are inserted between the bed plate 10 and the base plate 14. The transfer devices can be constituted for example by the forks 59 of a fork-lift truck.

During step d), the pusher pistons 18 are lowered. Liquid is discharged from the lower chambers 29 of the pusher pistons 18 and the upper chambers 28 are loaded with air.

During step e), the traction devices 50 engage the strike plate 16 and the traction piston 49 is lowered so as to generate a downward traction force on the strike plate 16.

**[0037]** The traction piston 49 is raised by introducing air into the lower chamber 57 and discharging oil from the upper chamber 56. A rotation of the rotating part 51 and of the rod 54 through 90° allows to arrange the traction devices 50 in a rotated position that is suitable to engage the strike plate 16. A lowering of the traction piston 49 allows to engage the strike plate 16. This lowering is performed by feeding pressurized oil to the upper chamber 56 and by discharging air from the lower chamber 57 of the traction piston 49.

**[0038]** The invention allows to achieve at least the following advantages:

The traction devices for engaging the strike plate by traction and for disengaging it on command allow to automate mold replacement operations, radically increasing the operating speed, particularly for conventional-type molds that require the removal of all the parts arranged above the bed plate, from the base plate upward.

**[0039]** The provision of the traction devices by virtue of a rotary part ensures a particularly reliable operation, since the movable structure is very simple and monolithic and therefore not very prone to breakage. Even in case of mold seizure, this embodiment ensures that it is possible to apply the force sufficient to open the mold without problems.

**[0040]** The traction piston can retract inside the bed plate, so as to speed up mold changing operations.

**[0041]** The pusher cylinder-and-piston units can be checked before installation in the bed plate; in particular,

it is possible to check hydraulic tightness, movement, et cetera. Insertion in the bed plate is furthermore particularly simple.

**[0042]** Worn units can be replaced easily, without having to perform work on the bed plate.

**[0043]** The units can be fed simply from below, by virtue of pipes, avoiding the need to produce long horizontal holes in the bed plate.

**[0044]** The abutment arranged above the cylinder prevents the accidental escape of the pistons during transport.

**[0045]** The presence of the double action and of the upper chamber allows to retract the pistons more easily inside the bed plate.

**[0046]** The air bubbles that are present in the oil can be eliminated by suction through the gaskets. Air bubble elimination is very important, since precision in operation is based on the incompressibility of the oil and therefore on the parallel movement of the four pusher pistons.

**[0047]** A Venturi suction device allows to provide an appreciable degree of vacuum in a simple manner. A decanting device allows to separate the oil from the air, sending only air to the suction device.

**[0048]** Operation is reliable, even if the strike plate should happen to be, due to accidental reasons, in a position that is far from parallelism with respect to the bed plate, in this case it is in fact sufficient to eliminate the accidental reason without this entailing permanent damage to the device.

**[0049]** The fact that the pusher pistons can retract fully inside the bed plate allows to remove without difficulty all the parts that are arranged above the bed plate. This allows to use the large number of existing conventional-type molds.

**[0050]** Furthermore, the simple support coupling between the pusher pistons and the strike plate allows particularly quick removal of the mold.

**[0051]** The presence of self-centering seats in the simple support coupling between the pusher pistons and the strike plate allows very fast installation of the new mold, since the delicate step of positioning is performed automatically by the self-centering seats.

**[0052]** The extension of the strike plate through the base plate allows the pusher pistons to reach the strike plate even with a reduced length of the pusher pistons, which can thus retract more easily fully inside the bed plate. The base plate can furthermore be easily removed together with the overlying parts for mold changing.

## Claims

1. Pressing device for use in a pressing apparatus for dry pressing of granular or powdery material, which comprises:

a bed plate (10) for withstanding a pressing force that is discharged onto a lower mold (11);

a strike plate (16) that is arranged above said bed plate (10), in order to support a lower plunger (13) of said lower mold (11);

lifting means for lifting said strike plate (16) consisting of pusher pistons (18), wherein said strike plate (16) is supported by said pusher pistons (18) by virtue of a simple resting coupling, so as to freely allow an accidental movement of said strike plate (16) that is not parallel to said bed plate (10); and

a base plate (14) that is arranged above said bed plate (10) and below said strike plate (16), said base plate (14) supporting a template (12) of said lower mold (11) and being removable, so that by removing said base plate (14) it is also possible to remove said strike plate (16) and said lower mold (11), said base plate (14) being fixable to said bed plate (10), so as to remain fixed during a pressing cycle.

2. Device according to claim 1, comprising; pusher cylinders (19) being provided for said pusher pistons (18), which are preferably formed into said bed plate (10).

3. Device according to at least one of the preceding claims comprising traction devices (50) for engaging said strike plate (16) by traction and disengaging it on command; said traction devices (50) preferably comprise a cylinder (47) connected to said bed plate (10) and that has a traction piston (49) that is inserted in said traction cylinder (47).

4. Device according to at least one of the preceding claims comprising a flow splitter (30) for distributing the same flow to each one of said pusher cylinders (19), so that said strike plate (16) can be moved vertically, parallel to itself.

5. Device according to at least one of the preceding claims, wherein said traction devices (50) comprise a rotating part (51) with an enlarged top, so that a first rotation angle of said rotating part (51) allows to engage said strike plate (16) and so that a second rotation angle allows to disengage said strike plate (16); preferably said first rotation angle and said second rotation angle are displaced by 90°.

6. Device according to claim 5, wherein said enlarged top has a hemispherical shape that is truncated on two opposite sides.

7. Device according to at least one of claims 5 to 6, wherein said rotating part (51, 54) passes through a body of said traction piston and is actuated from below by virtue of an actuation device (55), that preferably is a hydraulic rotary actuator with limited rotation.

8. Device according to at least one of the preceding claims, wherein said traction cylinder and piston unit (47, 49) is of the double-acting type and has an upper chamber (56) that is fed with a liquid and a lower chamber (57) that is fed with a fluid at a lower pressure that is preferably constituted by air.
9. Device according to at least one of the preceding claims, comprising a hole (20) in said bed plate for accommodating each one of said pusher cylinders (19), an upper abutment (37) for each one of said pusher cylinders (19), so that each one of said pusher pistons (18) can pass through a hole of said abutment (37); preferably an upper surface (43) of said abutment (37) is at a level that is not higher than the upper surface of said bed plate (10); preferably said pusher cylinders (18), provided with said abutment (37), which is already fixed, are inserted in said bed plate (10) from above.
10. Device according to at least one of the preceding claims, wherein a unit formed by said cylinder (19) and by said pusher piston (18) is of the double-acting type and has an upper chamber (28) and a lower chamber (29); preferably said upper chamber (28) being fed with a gas.
11. Device according to claim 10, wherein a wall of said pusher cylinder has a first substantially vertical hole (44) that is preferably combined with a substantially horizontal hole (45) to feed said upper chamber (28) from below; preferably said cylinder (19) has a second substantially vertical hole (46) for feeding said lower chamber with a liquid from below.
12. Device according to at least one of the preceding claims, wherein a length of said pusher pistons (18) being such as to allow lowering of the top (22) of said pistons (18) to a level that is not higher than the upper surface of said bed plate (10).
13. Device according to at least one of the preceding claims, wherein said support coupling comprises an extension (24) of said strike plate (16) through said base plate (14).
14. Device according to at least one of the preceding claims, wherein said support coupling is self-centering and preferably comprises the coupling of a concave profile (27) to a convex profile (22).
15. Device according to claim 14, wherein said concave profile (27) is rigidly coupled to said strike plate (16) and said convex profile (22) is rigidly coupled to said top of said pistons (18).
16. Device according to at least one of claims 10 to 15, comprising a suction device (33) that can be con-

nected to each upper chamber (28) of said pusher cylinder-and-piston units, so as to aspirate gas from said lower chamber (29), through a gasket (34); preferably said suction device is a Venturi device and is connected to said upper chambers (28) by virtue of a valve (35) that is capable of cutting off said suction device (33) and of sending pressurized air to said upper chambers (28).

17. Device according to at least one of the preceding claims comprising at least one proportional valve (7) for adjusting a flow line connected with said pistons (18); at least one encoder (6) for detecting a position of said strike plate (16) and consequently adjusting said proportional valve (7)

18. Pressing apparatus having a pressing device according to at least one of the preceding claims.

### Patentansprüche

1. Vorrichtung zur Verwendung in einer Preßeinrichtung zum Trockenpressen eines granulat- oder pulverförmigen Materials mit:

einer Grundplatte (10) zum Widerstehen einer Druckkraft, die auf eine untere Form (11) wirkt, einer Grundplatte (16), die über der Grundplatte (10) angeordnet ist, um einen unteren Kolben (13) der unteren Form (11) zu halten, einem Hebemittel zum Anheben der Grundplatte (16) bestehend aus Druckkolben (18), wobei die Grundplatte (16) durch die Druckkolben (18) aufgrund einer einfachen Ruhekupplung gehalten ist, um eine zufällige Bewegung der Grundplatte (16) frei zu erlauben, die nicht parallel zu der Grundplatte (10) ist, und einer Basisplatte (14), die über der Grundplatte (10) und unter der Grundplatte (16) angeordnet ist, wobei die Basisplatte (14) eine Schablone (12) der unteren Form (11) trägt und entfernbar ist, so daß durch Entfernen der Basisplatte (14) es ebenfalls möglich ist, die Grundplatte (16) und die untere Form (11) zu entfernen, wobei die Basisplatte (14) an der Grundplatte (10) befestigbar ist, um während eines Preßzyklusses befestigt zu verbleiben.

2. Vorrichtung nach Anspruch 1, **dadurch gekennzeichnet, daß** sie ferner aufweist: Druckzylinder (19), die für die Druckkolben (18) vorgesehen sind, die vorzugsweise in der Grundplatte (10) gebildet sind.
3. Vorrichtung nach zumindest einem der vorhergehenden Ansprüche, **dadurch gekennzeichnet, daß** die Zugvorrichtungen (50) zum Koppeln durch

- Zug und Entkoppeln der Grundplatte (16) auf Befehl aufweist, wobei die Zugvorrichtungen (50) vorzugsweise einen mit der Grundplatte (10) verbundenen Zylinder (47) aufweisen, der einen Zugkolben (49) aufweist, der in den Zugzylinder (47) eingesetzt ist.
4. Vorrichtung nach zumindest einem der vorhergehenden Ansprüche, **dadurch gekennzeichnet, daß** sie einen Strömungsteiler (30) zum Verteilen einer gleichen Strömung auf jeden der Druckzylinder (19) aufweist, so daß die Grundplatte (16) vertikal parallel zu sich selbst bewegt werden kann.
5. Vorrichtung nach zumindest einem der vorhergehenden Ansprüche, **dadurch gekennzeichnet, daß** die Zugvorrichtungen (50) ein rotierendes Element (51) mit einem vergrößerten Kopf aufweisen, so daß ein erster Drehwinkel des rotierenden Elementes (51) ein Koppeln der Grundplatte (16) erlaubt und so daß ein zweiter Drehwinkel ein Entkoppeln der Grundplatte (16) erlaubt, wobei vorzugsweise der erste Drehwinkel und der zweite Drehwinkel um 90° zueinander versetzt sind.
6. Vorrichtung nach Anspruch 5, **dadurch gekennzeichnet, daß** der vergrößerte Kopf eine halbrunde Gestalt aufweist, die an zwei gegenüberliegenden Seiten abgerundet ist.
7. Vorrichtung nach zumindest einem der Ansprüche 5 bis 6, **dadurch gekennzeichnet, daß** das rotierende Element (51, 54) durch einen Körper des Zugkolbens reicht und von unten aufgrund einer Betätigungsvorrichtung (55) betätigt wird, die vorzugsweise ein hydraulischer Drehaktuator mit begrenzter Rotation ist.
8. Vorrichtung nach zumindest einem der vorhergehenden Ansprüche, **dadurch gekennzeichnet, daß** die Zug-Kolbenzylindereinheit (47, 49) doppelt wirkend ist und eine obere Kammer (56), der eine Flüssigkeit zugeführt wird, und eine untere Kammer (57) aufweist, der ein Fluid mit einem geringeren Druck zugeführt wird, das vorzugsweise Luft ist.
9. Vorrichtung nach zumindest einem der vorhergehenden Ansprüche, **dadurch gekennzeichnet, daß** sie eine Öffnung (20) in der Grundplatte zur Aufnahme der Druckzylinder (19) und ein oberes Widerlager (37) für jeden der Druckzylinder (19) aufweist, so daß jeder der Druckkolben (18) durch eine Öffnung des Widerlagers (37) geführt werden kann, wobei vorzugsweise eine obere Oberfläche (43) des Widerlagers (37) sich auf einem Niveau befindet, das nicht höher ist, als die obere Oberfläche der Grundplatte (10), wobei die Druckzylinder (18) vorzugsweise mit dem bereits befestigten Widerlager (37) versehen von oben in die Grundplatte (10) eingesetzt sind.
10. Vorrichtung nach zumindest einem der vorhergehenden Ansprüche, **dadurch gekennzeichnet, daß** eine aus dem Zylinder (19) und dem Druckkolben (18) gebildete Einheit doppelt wirkend ist und eine obere Kammer (28) und eine untere Kammer (29) aufweist, wobei vorzugsweise die obere Kammer (28) mit einem Gas gespeist wird.
11. Vorrichtung nach Anspruch 10, **dadurch gekennzeichnet, daß** eine Wand des Druckzylinders eine erste im wesentlichen vertikale Öffnung (44) aufweist, die vorzugsweise mit einer im wesentlichen horizontalen Öffnung (45) kombiniert ist, um die obere Kammer (28) von unten zu speisen, wobei vorzugsweise der Zylinder (19) eine zweite im wesentlichen vertikale Öffnung (46) zum Speisen der unteren Kammer mit einer Flüssigkeit von unten aufweist.
12. Vorrichtung nach zumindest einem der vorhergehenden Ansprüche, **dadurch gekennzeichnet, daß** eine Länge des Druckkolbens (18) derart ausgebildet ist, um ein Absenken des Kopfes (22) der Kolben (18) auf ein Niveau zu erlauben, das nicht höher als die obere Oberfläche der Grundplatte (10) ist.
13. Vorrichtung nach zumindest einem der vorhergehenden Ansprüche, **dadurch gekennzeichnet, daß** die Haltekupplung eine Verlängerung (24) der Grundplatte (16) durch die Basisplatte (14) aufweist.
14. Vorrichtung nach zumindest einem der vorhergehenden Ansprüche, **dadurch gekennzeichnet, daß** die Haltekupplung selbst-zentrierend ist und vorzugsweise der Anschluss von einem konkaven Profil (27) zu einem konvexen Profil (22) aufweist.
15. Vorrichtung nach Anspruch 14, **dadurch gekennzeichnet, daß** das konkave Profil (27) starr mit der Grundplatte (16) gekoppelt ist und das konvexe Profil (22) starr mit dem Kopf der Kolben (18) gekoppelt ist.
16. Vorrichtung nach zumindest einem der Ansprüche 10 bis 15, **dadurch gekennzeichnet, daß** sie eine Saugvorrichtung (33) aufweist, die mit jeder oberen Kammer (28) der Druck-Zylinderkolben-Einheiten verbunden werden kann, um Gas von der unteren Kammer (29) durch eine Dichtung (34) abzusaugen, wobei vorzugsweise die Saugvorrichtung eine Venturi-Vorrichtung ist und mit den oberen Kammern (28) mittels eines Ventils (35) verbunden ist, das zum Abschalten der Saugvorrichtung und zum Fördern von Druckluft an die obere Kammer (28) geeignet ist.
17. Vorrichtung nach zumindest einem der vorherge-

henden Ansprüche, **dadurch gekennzeichnet, daß** sie zumindest ein Proportionalventil (7) zum Einstellen einer mit den Kolben (18) verbundenen Strömungsleitung und zumindest einen Geber (6) zum Detektieren einer Stellung der Grundplatte (16) und daraus folgend zum Einstellen des Proportionalventils (7) aufweist.

- 18.** Preßeinrichtung **dadurch gekennzeichnet, daß** diese eine Preßvorrichtung nach zumindest einem der vorhergehenden Ansprüche aufweist.

## Revendications

- 1.** Dispositif de pressage à utiliser dans un appareil de pressage destiné à presser à sec un matériau granulaire ou pulvérulent, qui comprend :

- une plaque d'assise (10) destinée à supporter une force de pression qui est exercée sur un moule inférieur (11) ;

- une plaque de poussée (16) qui est disposée au-dessus de ladite plaque d'assise (10), afin de supporter un piston plongeur inférieur (13) dudit moule inférieur (11) ;

- des moyens de levage permettant de lever ladite plaque de poussée (16), composés de pistons pousseurs (18), ladite plaque de poussée (16) étant supportée par lesdits pistons pousseurs (18) au moyen d'un accouplement simple par appui, de façon à autoriser librement tout mouvement fortuit de ladite plaque de poussée (16) non parallèle à ladite plaque d'assise (10) ; et

- une plaque de base (14) qui est disposée au-dessus de ladite plaque d'assise (10) et en-dessous de ladite plaque de poussée (16), ladite plaque de base (14) supportant un gabarit (12) dudit moule inférieur (11) et étant amovible, de sorte qu'en retirant ladite plaque de base (14), il est aussi possible de retirer ladite plaque de poussée (16) et ledit moule inférieur (11), ladite plaque de base (14) pouvant être fixée à ladite plaque d'assise (10) de façon à rester fixe pendant un cycle de pressage.

- 2.** Dispositif selon la revendication 1, comprenant des cylindres pousseurs (19) prévus pour lesdits pistons pousseurs (18), lesquels sont de préférence formés dans ladite plaque de fondation (10).

- 3.** Dispositif selon au moins l'une des revendications précédentes, comprenant des dispositifs de traction (50) prévus pour être en prise avec ladite plaque de poussée (16) par traction et pour la libérer sur commande ; lesdits dispositifs de traction (50) comprenant de préférence un cylindre (47) relié à ladite

plaque d'assise (10) et comportant un piston de traction (49) qui est inséré dans ledit cylindre de traction (47).

- 4.** Dispositif selon au moins l'une des revendications précédentes, comprenant un diviseur de flux (30) prévu pour répartir le même flux vers chacun des cylindres pousseurs (19), de sorte que ladite plaque de poussée (16) peut être déplacée verticalement, parallèle à elle-même.

- 5.** Dispositif selon au moins l'une des revendications précédentes, dans lequel lesdits dispositifs de traction (50) comprennent une partie rotative (51) présentant une portion supérieure élargie, de sorte qu'un premier angle de rotation de ladite partie rotative (51) permet d'être en prise avec ladite plaque de poussée (16), et de sorte qu'un second angle de rotation permet de libérer ladite plaque de poussée (16) ; le déplacement entre ledit premier angle de rotation et ledit second angle de rotation étant de préférence de 90 °.

- 6.** Dispositif selon la revendication 5, dans lequel ladite portion supérieure élargie présente une forme hémisphérique qui est tronquée au niveau de deux côtés opposés.

- 7.** Dispositif selon au moins l'une des revendications 5 à 6, dans lequel ladite partie rotative (51, 54) passe à travers un corps du dit piston de traction et est actionnée depuis le bas au moyen d'un dispositif actionneur (55), qui est de préférence un actionneur rotatif hydraulique présentant une rotation limitée.

- 8.** Dispositif selon au moins l'une des revendications précédentes, dans lequel ladite unité cylindre de traction - piston (47, 49) est de type à double action et comporte une chambre supérieure (56) qui est alimentée par un liquide et une chambre inférieure (57) qui est alimentée par un fluide à une pression moindre, de préférence constitué par de l'air.

- 9.** Dispositif selon au moins l'une des revendications précédentes, comportant un orifice (20) dans ladite plaque d'assise, prévu pour loger chacun des dits cylindres pousseurs (19), une butée supérieure (37) pour chacun des dits cylindres pousseurs (19) de façon telle que chacun des dits pistons pousseurs (18) peut passer par un orifice de la dite butée (37) ; une surface supérieure (43) de ladite butée (37) se trouvant de préférence à un niveau qui n'est pas supérieur à la surface supérieure de ladite plaque d'assise (10) ; de préférence lesdits cylindres pousseurs (18), munis de ladite butée (37), qui est déjà fixée, étant insérés dans ladite plaque d'assise (10) depuis le dessus.

10. Dispositif selon au moins l'une des revendications précédentes, dans lequel une unité formée par ledit cylindre (19) et par ledit piston pousseur (18) est de type à double action et possède une chambre supérieure (28) et une chambre inférieure (29) ; ladite chambre supérieure (28) étant de préférence alimentée par un gaz. 5
11. Dispositif selon la revendication 10, dans lequel une paroi du dit cylindre pousseur présente un premier orifice sensiblement vertical (44), qui est de préférence combiné à un orifice sensiblement horizontal (45) pour alimenter ladite chambre supérieure (28) depuis le bas ; ledit cylindre (19) présentant de préférence un second orifice sensiblement vertical (46) pour alimenter ladite chambre inférieure avec un liquide depuis le bas. 10  
15
12. Dispositif selon au moins l'une des revendications précédentes, dans lequel une longueur des dits pistons pousseurs (18) est telle qu'elle permet un abaissement de la partie supérieure (22) desdits pistons (18) à un niveau qui n'est pas supérieur à la surface supérieure de ladite plaque d'assise (10). 20  
25
13. Dispositif selon au moins l'une des revendications précédentes, dans lequel ledit accouplement par appui comprend une extension (24) de ladite plaque de poussée (16) à travers ladite plaque de base (14). 30
14. Dispositif selon au moins l'une des revendications précédentes, dans lequel ledit accouplement par appui est à auto-centrage et comprend de préférence l'accouplement d'un profil concave (27) à un profil convexe (22). 35
15. Dispositif selon la revendication 14, dans lequel ledit profil concave (27) est couplé de façon rigide à ladite plaque de poussée (16) et ledit profil convexe (22) est couplé de façon rigide à ladite partie supérieure des dits pistons (18). 40
16. Dispositif selon au moins l'une des revendications 10 à 15, comprenant un dispositif d'aspiration (33) qui peut être raccordé à chaque chambre supérieure (28) des dites unités cylindre pousseur - piston, de façon à aspirer du gaz depuis ladite chambre inférieure (29) via un joint d'étanchéité (34) ; ledit dispositif d'aspiration étant de préférence un dispositif Venturi et étant raccordé aux dites chambres supérieures (28) au moyen d'une soupape (35) qui est capable de couper ledit dispositif d'aspiration (33) et d'envoyer de l'air comprimé vers lesdites chambres supérieures (28). 45  
50  
55
17. Dispositif selon au moins l'une des revendications précédentes, comprenant au moins une soupape proportionnelle (7) pour le réglage d'une ligne d'écoulement raccordée aux dits pistons (18); au moins un codeur (6) permettant de détecter une position de ladite plaque de poussée (16) et de régler en conséquence ladite soupape proportionnelle (7).
18. Appareil de pressage comportant un dispositif de pressage selon au moins l'une des revendications précédentes.

FIG. 1

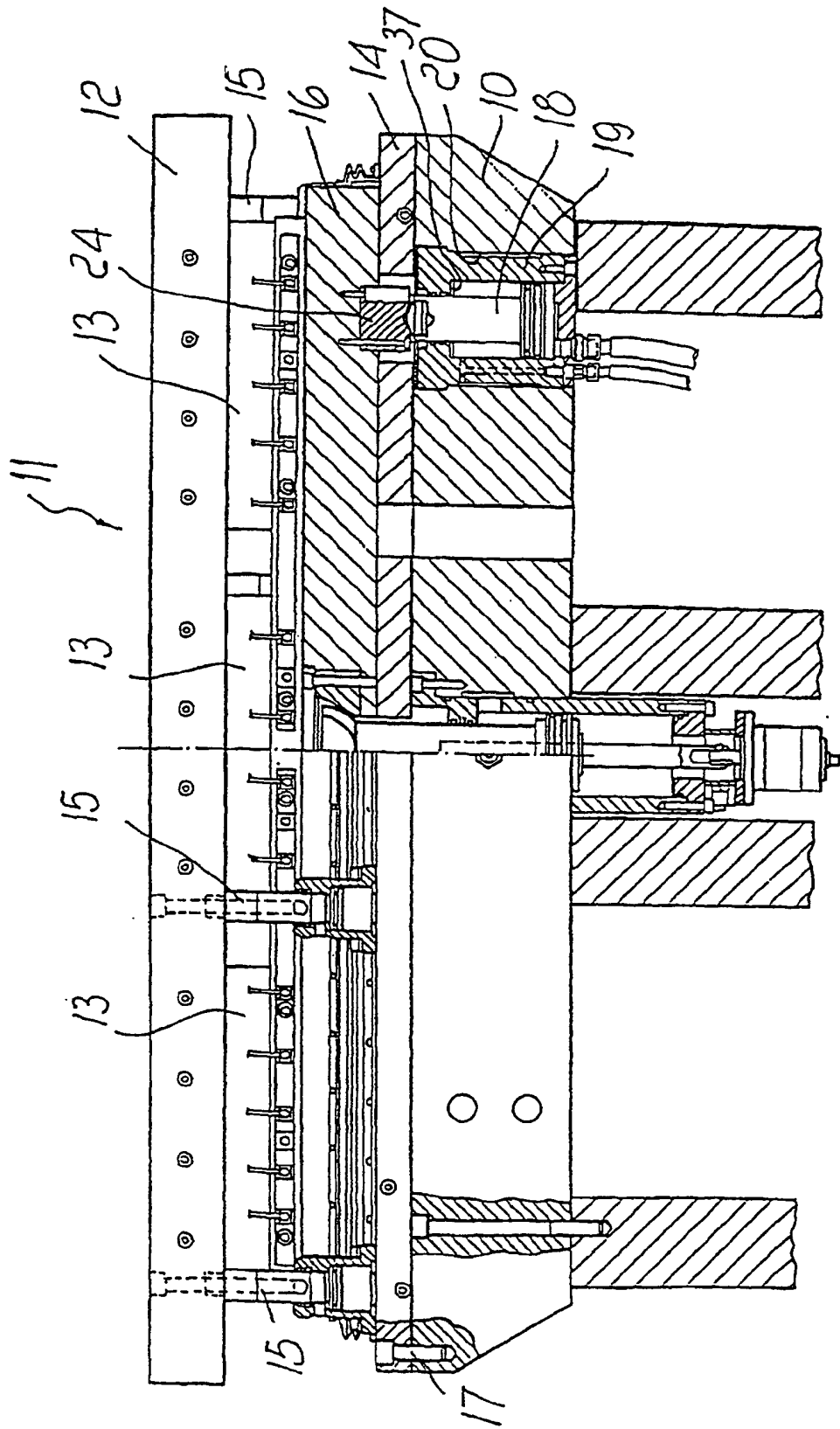

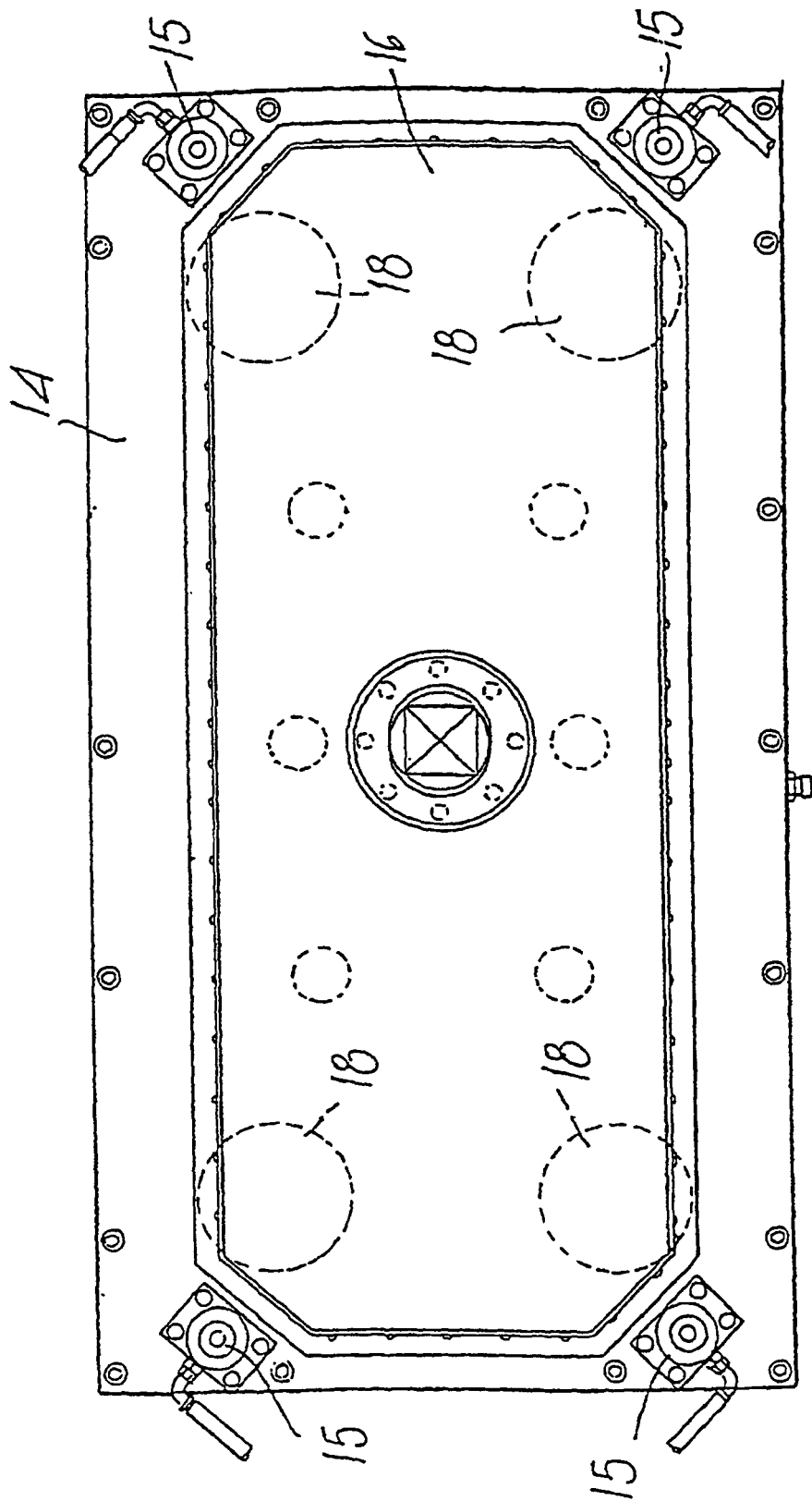
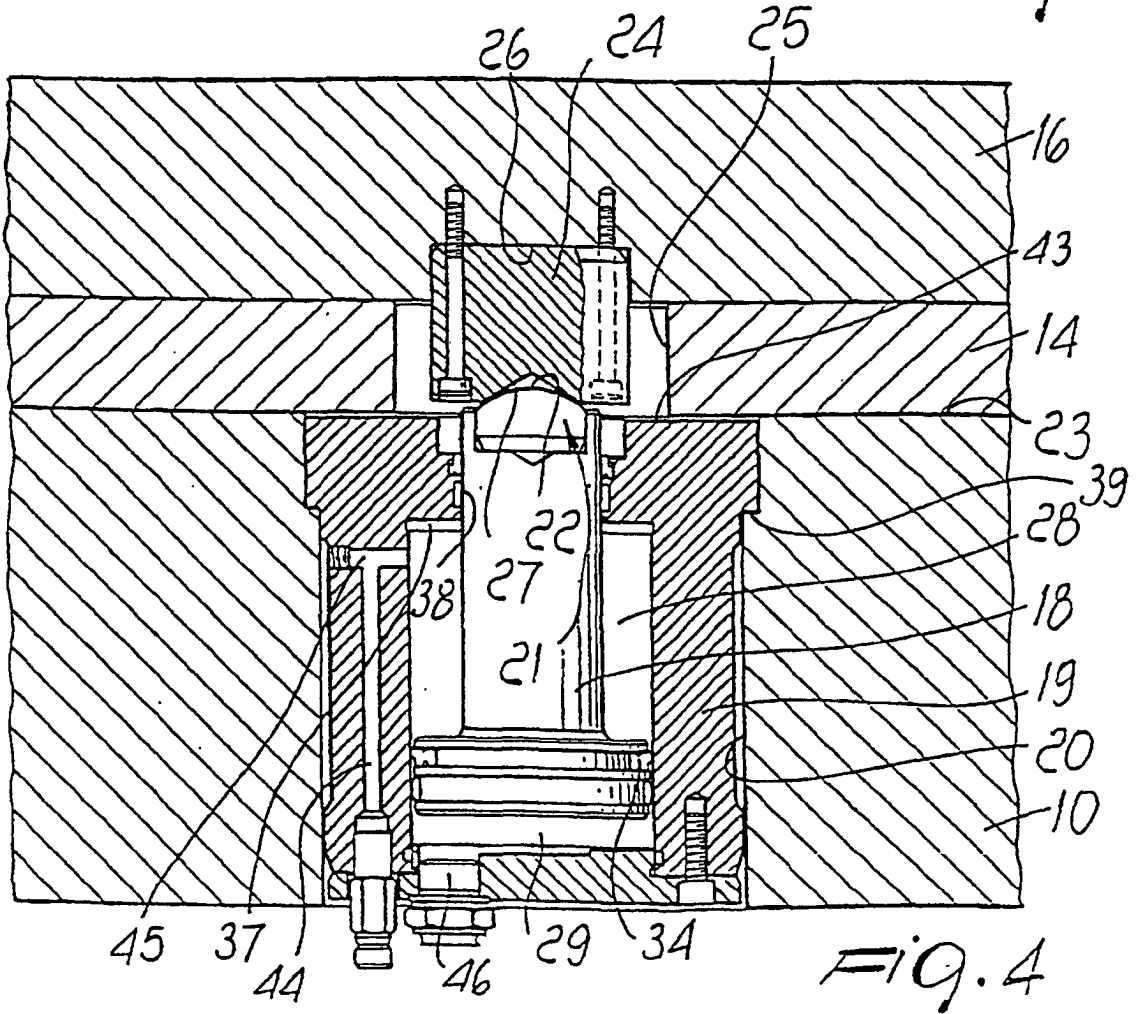
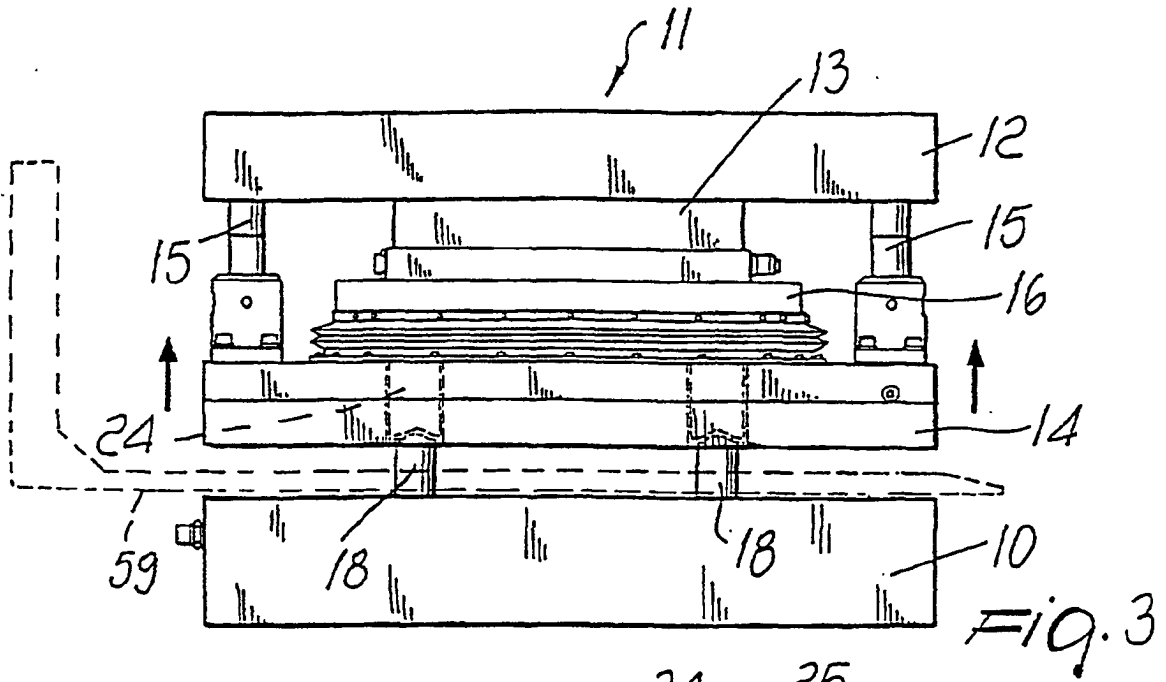

Fig. 2



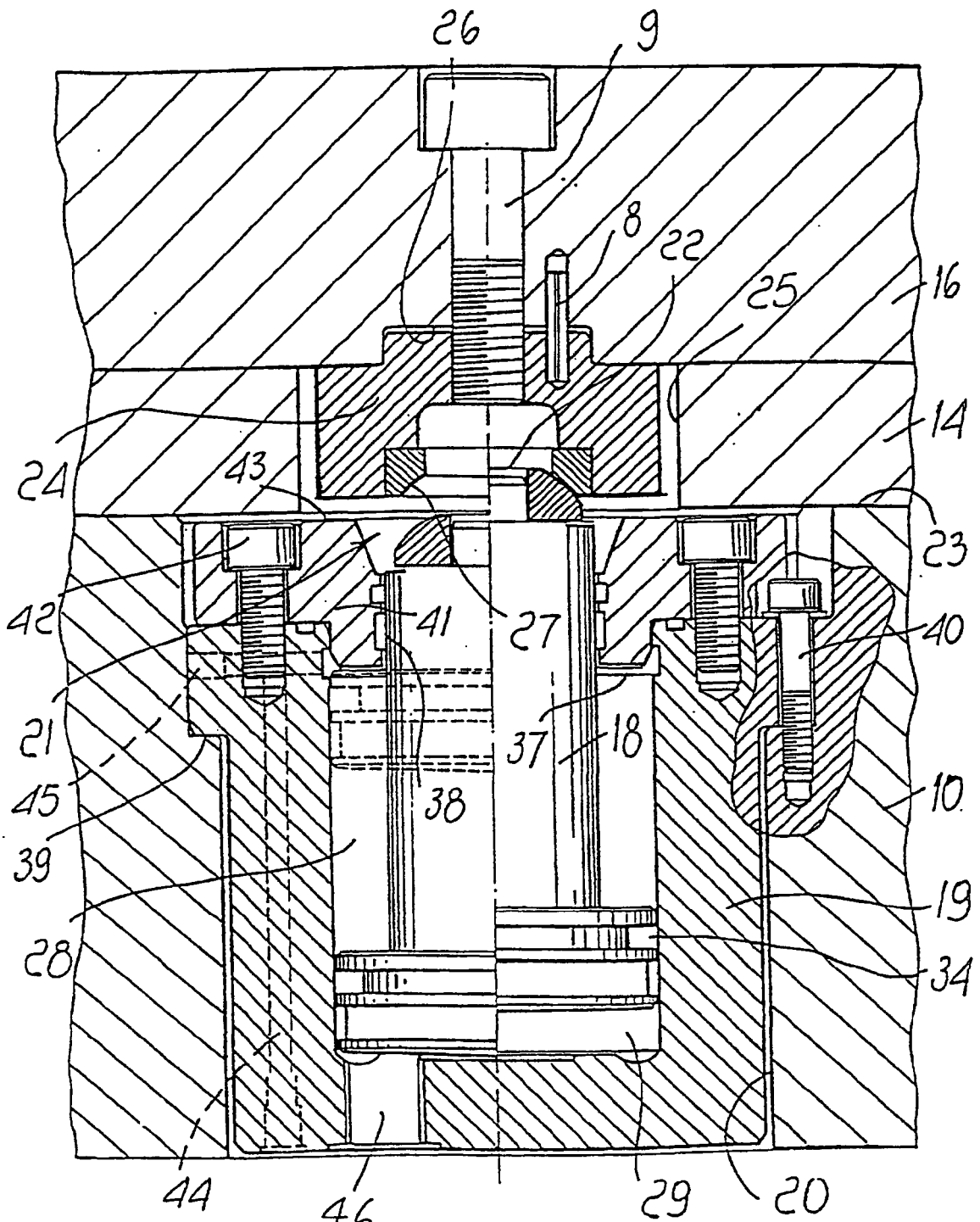

FIG. 5

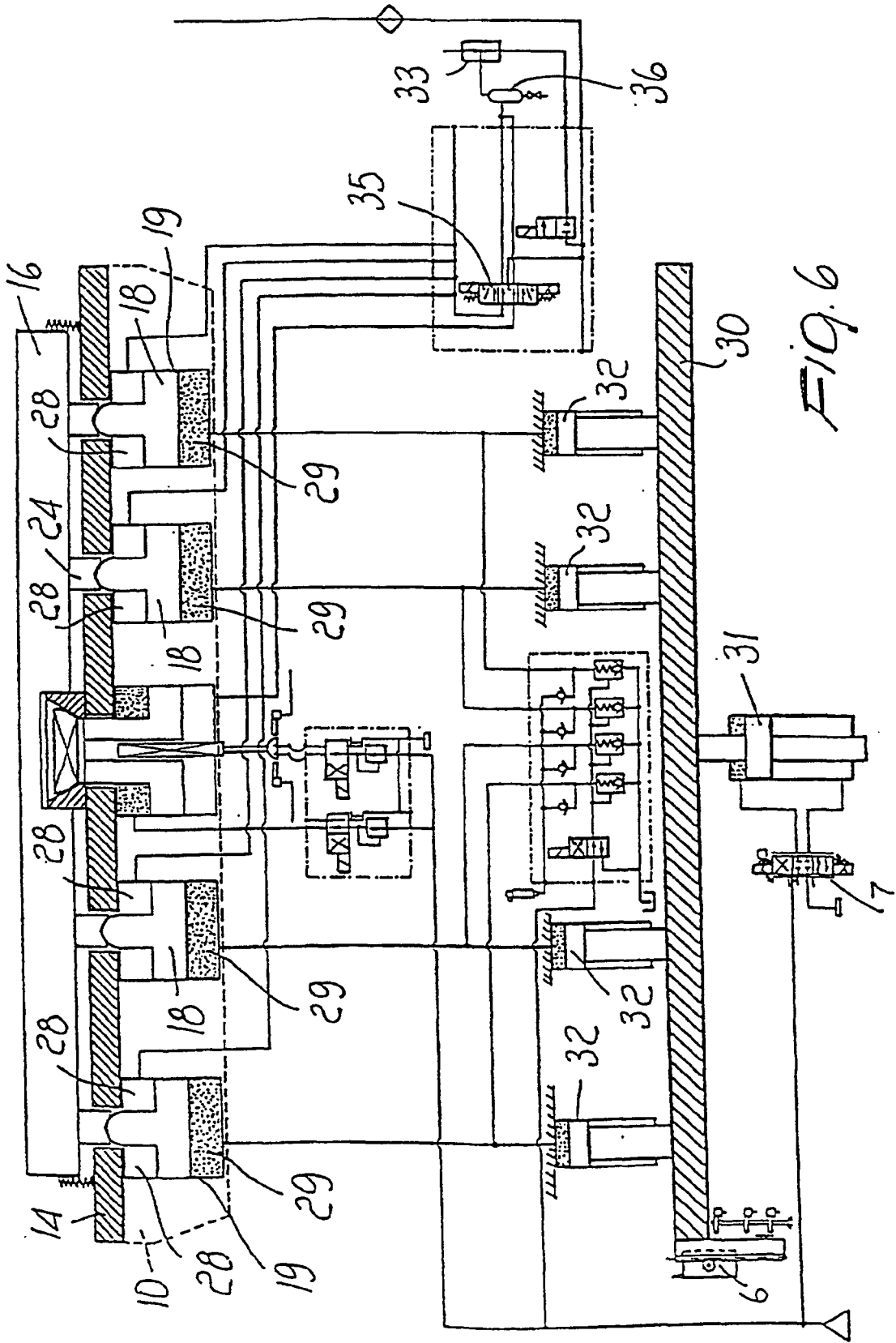

FIG. 6

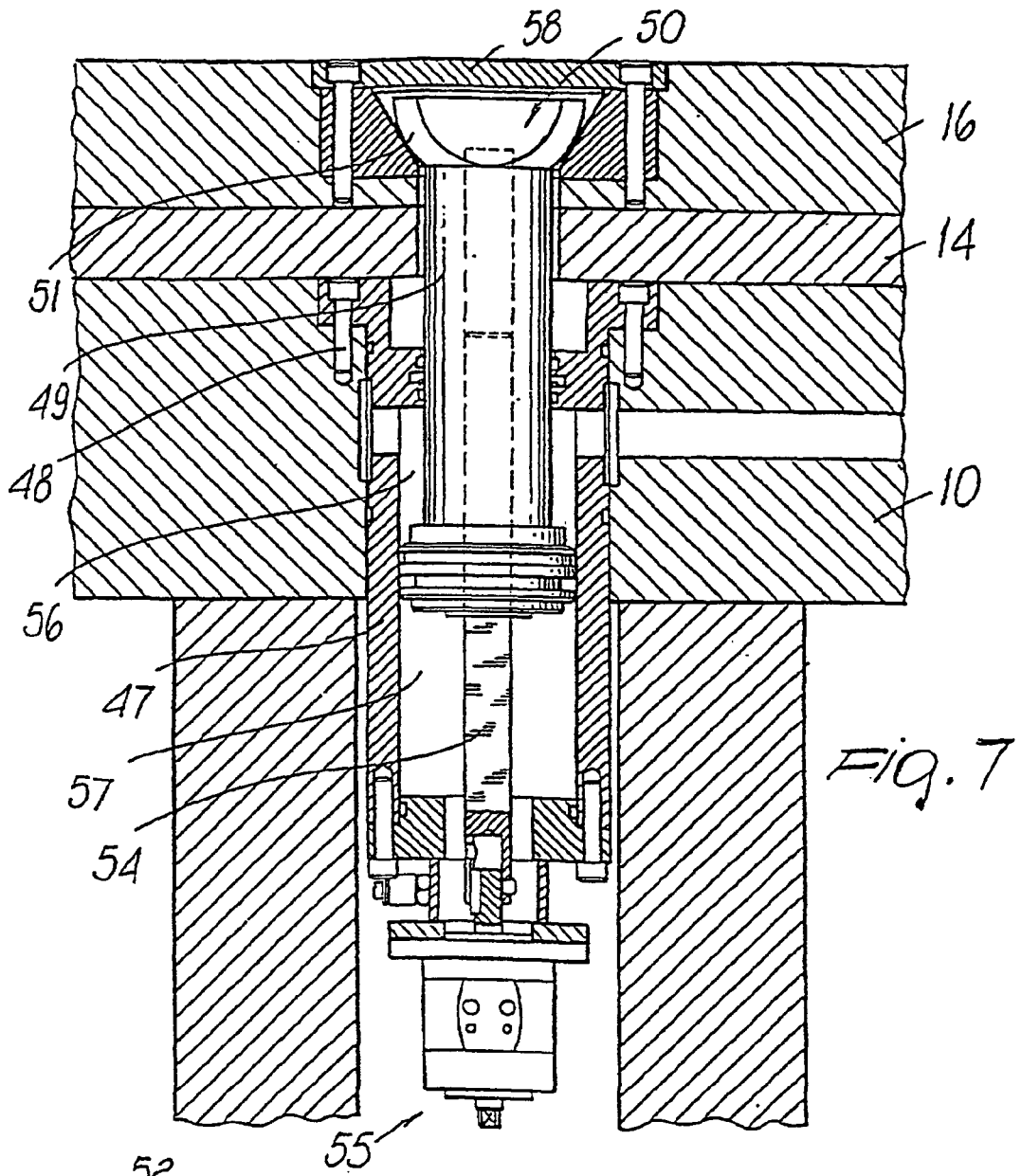

FIG. 7

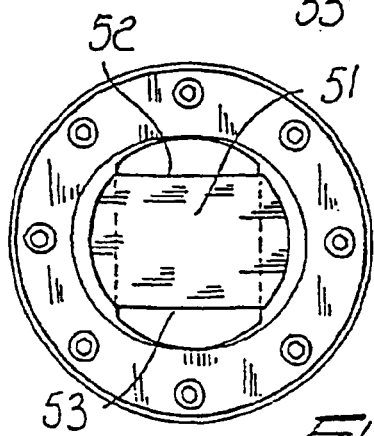

FIG. 8

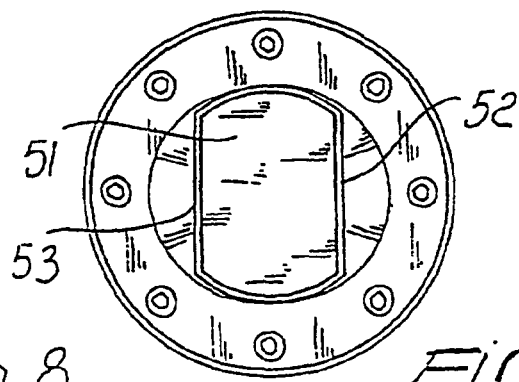

FIG. 9