

(19) World Intellectual Property Organization
International Bureau



(43) International Publication Date
29 November 2001 (29.11.2001)

PCT

(10) International Publication Number
WO 01/89419 A1

- (51) International Patent Classification⁷: **A61F 2/06** **M.** [US/US]; 168 Osgood Street, N. Andover, MA 01845 (US). **RAIJMAN, Isaac** [US/US]; 549 S. Third Street, Bell Aire, TX 77401 (US).
- (21) International Application Number: PCT/US01/16132
- (22) International Filing Date: 18 May 2001 (18.05.2001) (74) Agent: **LORUSSO, Mark, D.**; Kirkpatrick & Lockhart LLP, 75 State Street, Boston, MA 02109-1808 (US).
- (25) Filing Language: English (81) Designated States (*national*): JP, US.
- (26) Publication Language: English (84) Designated States (*regional*): European patent (AT, BE, CH, CY, DE, DK, ES, FI, FR, GB, GR, IE, IT, LU, MC, NL, PT, SE, TR).
- (30) Priority Data:
60/205,744 19 May 2000 (19.05.2000) US
- (71) Applicant (*for all designated States except US*): **C.R. BARD, INC.** [US/US]; 730 Central Avenue, Murray Hill, NJ 07974 (US). **Published:**
— *with international search report*
- (72) Inventors; and *For two-letter codes and other abbreviations, refer to the "Guidance Notes on Codes and Abbreviations" appearing at the beginning of each regular issue of the PCT Gazette.*
- (75) Inventors/Applicants (*for US only*): **AZNOIAN, Harold,**

(54) Title: STENTS AND STENTING METHODS

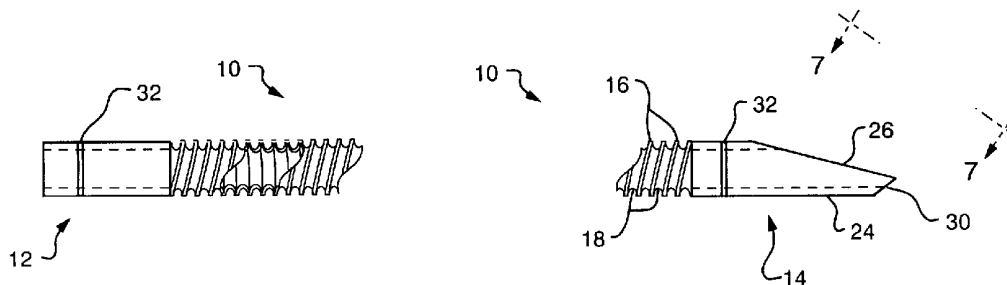

(57) Abstract: A biliary stent (10) is constructed of thermoplastic material with ridges (16) and valleys (18) formed along the outer surface of the stent that provide a helical, thread-like configuration. The ridges (16) and valleys (18) can be formed in a variety of configurations, depths and pitches to accommodate different delivery devices and different anatomical features of the biliary tree. The ridges (16) and valleys (18) provide additional mechanical engagement with the luminal walls of the biliary tract to prevent unwanted displacement of the implanted stent (10) from a selected implant site. The stent (10) is configured to optionally have an elongate distal end (14) to facilitate the transmission of biliary fluids through the stent (10). Optional radiopaque markers (32) are provided on one or both ends (12, 14) of the stent (10) to allow for fluoroscopic visualization of the stent (10) orientation and placement within the biliary tract.

WO 01/89419 A1

STENTS AND STENTING METHODS

Field of the Invention

This invention relates to stents and, in particular, to stents adapted for use in the biliary tract.

Biliary stents, for many years, have been made in the form of a polymer tube that can be advanced on a delivery catheter through an endoscope and into the bile duct where it is deployed. The tubular stent is selected to be sufficiently strong to resist collapse to maintain an open lumen through which digestive liquids can flow into the digestive tract. Among the desirable features of such a stent is that it be longitudinally flexible to be advanced along a path that may include sharp bends. The stent also should maintain its intended position within the bile duct without migrating from that position.

Background of the Invention

Polymeric tubular stents typically have been placed with a catheter-like device that includes telescoping inner and outer tubes, with the stent being mounted on the distal end of the inner tube and the distal end of the outer tube being in engagement with the proximal end of the stent. After the stent has been advanced and manipulated into the intended deployment site in the duct, the outer tube is maintained in its position while the inner tube is retracted, thereby leaving the stent within the biliary tract. Generally, such stents are provided with a retention member at each of the ends of the stent. Among the more common retention devices is the provision of one or more (four to eight are common) retention tabs formed by making an oblique slit along the length of the tube. Each slit defines a tab and enables the tab to project slightly radially outwardly of the outer surface of the tube to engage the luminal surface of the biliary duct to prevent migration. The tabs at the opposite ends of the stent extend toward the middle of the stent as well as radially outward.

- 2 -

The openings defined by the tab-forming skives may provide access to the interior of the stent of cellular or other material that may tend to develop into an obstruction tending to restrict flow through the stent. Also among the difficulties with prior polymeric stents is that in some cases the physician may not be able to push the stent through a constriction in the duct. It is among the general objects of the invention to provide a polymeric stent that displays a combination of significant longitudinal flexibility to facilitate its placement and, significant hoop strength to resist collapse of the stent. It is also among the objects of the invention to provide a new approach to securing the position of the stent within the duct as well as providing improved means by which the stent can be advanced through a tight restriction.

Summary of the Invention

The stent is formed from a tube of relatively stiff thermoplastic polymer to include ridges and valleys along its outer surface. The ridges and valleys may be helical and may form a thread-like configuration. The ridges and valleys are formed by thermoplastic deformation of the outer surface of the tube. The dimensions of the ridges and valleys can be varied to provide stents with different characteristics. The proximal and distal ends of the stent are preferably not provided with valleys or ridges. The distal end may be tapered to facilitate its entry into the biliary tract. Additionally, the distal end of the stent, which will serve as an inlet for biliary liquids, may have an elongate shape to provide a wider mouth for entry of such liquids. The device may be placed by pushing it to the desired location in the biliary tree, as is presently done, or in accordance with the invention, the stent can be rotated so that the helical ridges and valleys can serve as threads to advance the stent through a biliary stricture. The ridges engage the walls of the duct to secure the stent in place.

It is among the general objects of the invention to provide an improved stent, particularly for use in the biliary tract. Also among the objects of the invention are to provide a stent for use in the biliary tract in which the stent is easily fabricated from a polymeric material and embodies a construction that enables the characteristics of the stent to be varied easily; to provide a stent that is very flexible yet in which the

- 3 -

flexibility can be controlled during manufacture without changing the general structure of the stent and; to provide a stent that can be advanced into place by pushing it into place or by threading it through a biliary stricture.

Description of the Accompanying Drawings

The foregoing and other objects and advantages of the invention will be appreciated more fully from the following description thereof, with reference to the accompanying drawings wherein:

FIG. 1 is a side view of a stent in accordance with the invention in which portions of the stent are broken away;

FIG. 2 is an enlarged illustration of the presently preferred embodiment of the proximal end of the stent;

FIG. 3 is an embodiment of the distal end of the stent;

FIGS. 4 and 5 are top and side views of the thermo forming tool in engagement with the polymer tubing during formation of the stent;

FIG. 6 is an illustration, as seen along the axis of the starting tube during formation illustrating the manner in which the forming tool may press the starting tube against the outer surface of an undersized mandrel passing through the starting tube; and

FIG. 7 is an illustration of the distal end of an embodiment of the invention seen along the line 7-7 of FIG.1.

FIG. 8 is a side sectional view of a stent delivery device according to one embodiment of the invention.

Description of the Illustrative Embodiments

FIG. 1 illustrates, in side view, an embodiment of a stent 10 having a proximal end 12 and a distal end 14. The stent is formed from a tube of a polymer, commercially available from Victrex under the trade designation PEEK. The polymer is a polyetheretherketone, a linear aromatic semi-crystalline polymer. By way of example, for use as a biliary stent, the PEEK tubing may be of the order of 4 to 15 centimeters long having an outer diameter of between about 5 to 11 French (.065

- 4 -

inches to 0.143 inches). The wall thickness of the tubing may be of the order of about 0.005 inches. The PEEK material is thermoplastic and is formed from its extruded tubular configuration to that illustrated in FIG. 1 in which at least a portion of the length of the tube defines circumferentially extending external ridges 16 alternating with valleys 18. Preferably the ridges are formed in a helical, thread-like pattern.

The ridges 16 and valleys 18 are formed by applying a heated tool against the outer surface of the starting tube while rotating the tube and advancing the tool along the length of the rotating tube. FIGS. 4 and 5 illustrate, diagrammatically, a simplified technique for making the stent in which a generally conically shaped heated tip 20, as might be mounted on the end of a soldering iron, is applied to the external surface of the tubing while the tubing is rotated. The heat and pressure of the thermo forming tool 20 causes the thermoplastic tubing to become flowable in the localized region of the tool, thereby forming the valleys and ridges in the outer surface of the tube. We have found that it is possible to form the stent so that the inner surface of the tube also includes valleys and ridges corresponding to those on the outer surface by initially mounting the starting tube on a mandrel that has an outer diameter smaller than the inner diameter of the PEEK tubing. By way of example, we have found that mounting tubing 21 on a cylindrical mandrel 22 having an outer diameter about 0.010 inches smaller than the inner diameter of the starting tube (see FIG. 6), the configuration of inner and outer ridges and valleys results. It is believed that the inner surface of the tube also forms the ridges and valleys as a consequence of the localized cooling of the polymer immediately behind the axially advancing thermoforming tool. The clearance between the outer diameter of the mandrel and the inner diameter of the tubing is believed to contribute to the ability of the tubing to cool and form in that fashion.

The configuration of the thermo forming tool and the penetration depth to which the tool is applied to the outer surface of the PEEK tube can be varied to vary the characteristics of the stent. Additionally, the speed the tube is rotated and/or the speed the tool is advanced along the length of the tube can also be varied to alter the characteristics of the stent. Deeper grooves 18 may result in a thinner wall

having greater flexibility. Similarly, the pitch of the ridges 16 can be varied to vary the characteristics of the stent. As will be understood, increasing the number of threads per unit length of tube will increase the ability to finely adjust the placement of the stent via rotation while decreasing the number of threads per unit length of tube will decrease the ability to finely adjust the placement of the stent. The thread density can thus be adjusted to the particular characteristics of the luminal wall engaged by the stent. By way of example, a relatively rigid luminal wall will allow the use of a densely threaded stent. A relatively flexible or pliable luminal wall will require a stent with less dense and larger threading to ensure the preferably helical threads positively engage the wall to allow for advancement of the stent via rotation.

Preferably the proximal end of the starting tube will not have been formed to include the ridges and valleys. The proximal end of the stent may be configured and dimensioned as indicated in FIG. 2, in which the end is somewhat radiused or rounded. The rounding may be effected in any number of ways, such as by placing a mandrel having rounded ends within the tube and heating the tube proximal end while rotating the tube to form the rounded end. Another possible approach is to round over the proximal end with a solder tip held against the end while rotating the tube. A yet further approach is to use a knife held at an angle against the proximal end while rotating the tube. The distal end may be provided with a similarly fashioned tip, configured and dimensioned as indicated in FIG. 3. Alternately, it may be preferable to provide a modified tip 24 at the distal end 14 that has a generally tapered configuration to facilitate its entry through the papilla and into the biliary duct. The distal tip also may be configured to provide a distal opening 26 (FIG. 7) that is elongated and may be generally elliptical in shape. The elongated distal opening may facilitate entry of biliary liquids into the stent by providing an inlet opening larger than the transverse cross section of the lumen. To that end, the distal end of the tube is formed with an oblique cut 28 to expose an elongate inlet opening 26. The distal tip also may be beveled or otherwise tapered at its opposite side as shown at 30.

The stent may be provided with marker bands 32 at one or both of the distal and proximal ends. The marker bands 32 may be formed from gold or other suitably

radiopaque material. Circular grooves may be thermoformed in either or both of the ends 12, 14 and the radiopaque marker bands may be secured within those grooves. The ridges 16 and grooves 18 may be formed along substantially the full length of the stent or may be formed only along selected segments, for example, adjacent the ends of the stent, leaving the mid portion in its original tubular configuration. Conversely, only the mid portion may be provided with the ridges and valleys. Still further, ridges 16 and grooves 18 can be placed in selected sporadic groups along the length of the stent to achieve stiffness and flexibility characteristics tailored to particular needs or particular anatomy. The valleys and ridges can be made to be circumferentially segmented portions as opposed to being complete annular rings or completely helical by intermittently withdrawing and applying the thermoforming tool. Additionally, the pitch of the ridges and the depth of the valleys can be varied along any segment or along the full length of the stent in order to provide varied flexing characteristics for the stent.

The stent may be placed in the biliary duct either by the conventional pushing technique or by mounting it on a rotatable delivery catheter having a stent engaging member engageable with the proximal end of the stent. FIG. 8 shows a catheter 30 with a stent engaging member 32 in the form of an expandable collar that is received within the proximal end of the stent 10 and expanded securely against the inner luminal surface at the proximal end with wedge 36. Stent 10 is advanced to a selected site in the biliary tract with catheter 30. Wedge 30 is then proximally retracted to release the frictional engagement of engaging member 32 from stent 10. Stent 10 is then released using the conventional pushing technique. In an alternate embodiment, as the stent is advanced into the biliary duct, the an alternate delivery device (not shown) may be rotated to facilitate entry of the stent through an obstructed portion of the duct. To that end, it is preferred that the ridges and valleys be formed to define a helical path that will enable the stent to advance, in screw-like fashion through the obstruction. The stent may be released from the delivery device after it has been deployed in the desired location.

The ridges may engage the inner surface of the duct to secure the stent in place. Additionally, when the valley 18 is continuous, as defined by a helical path, it

- 7 -

may be possible for biliary liquids to flow between the outer surface of the stent and the wall of the biliary duct as well as through the stent itself. To perform the latter function, valleys 18 have to be formed with sufficient pitch, depth and/or angle to maintain an open channel since it is anticipated the duct wall will partially herniate into the valley. Another benefit of having a relatively deep valley is that such a configuration is expected to enhance the mechanical engagement of the stent to the duct wall.

It should be understood that the foregoing description of the invention is intended merely to be illustrative thereof and that other modifications, embodiments and equivalents may be apparent to those who are skilled in the art without departing from its principles. Having thus described the invention what we desire to claim and secure by letters patent is:

Claims

1. A tubular stent having an external surface, at least part of which is defined by circumferentially extending ridges and valleys.
2. The stent of claim 1 wherein the ridges and valleys are disposed helically along the outer surface of the stent.
3. The stent of claim 2 wherein the ridges and valleys extend at least partially along the full length of the stent.
4. The stent of claim 3 further comprising at least one marker band located adjacent at least one end of the stent.
5. The stent of claim 3 further comprising a proximal end and a distal end wherein the ends are free of ridges and valleys.
6. The stent of claim 1 wherein the ridges and valleys are disposed in partial circumferential segments at least partially along the full length of the stent.
7. The stent of claim 6 wherein the ridges and valley disposed in partial circumferential segments have a helical orientation relative to a longitudinal axis of the stent.
8. The stent of claim 7 further comprising at least one marker band located adjacent at least one end of the stent.

- 9 -

9. The stent of claim 7 further comprising a proximal end and a distal end wherein the ends are free of ridges and valleys.

10. The stent of claim 1 further comprising a proximal end and a distal end wherein the ridges and valleys are disposed on at least one of the ends.

11. The stent of claim 1 further comprising a proximal end and a distal end wherein the ridges and valleys are disposed in close proximity to at least one end.

12. The stent of claim 1 further comprising at least one marker band located adjacent to at least one end of the stent.

13. The stent of claim 1 further comprising a proximal end and a distal end wherein the ends are free of ridges and valleys.

14. The stent of claim 1 further comprising a proximal end and a distal end wherein at least one of the ends has an elongate inlet opening.

15. The stent of claim 14 wherein the distal end of the stent is beveled.

16. The stent of claim 1 wherein the stent comprises a polymer.

17. The stent of claim 16 wherein the polymer comprises polyetheretherketone.

18. A tubular biliary stent having an external surface, at least part of which is defined by circumferentially extending ridges and valleys.

- 10 -

19. The biliary stent of claim 18 wherein the ridges and valleys are disposed helically along the outer surface of the stent.

20. The biliary stent of claim 19 wherein the ridges and valleys extend at least partially along the full length of the stent.

21. The biliary stent of claim 20 further comprising at least one marker band located adjacent at least one end of the stent.

22. The biliary stent of claim 20 further comprising a proximal end and a distal end wherein the ends are free of ridges and valleys.

23. The biliary stent of claim 18 wherein the ridges and valleys are disposed in partial circumferential segments at least partially along the full length of the stent.

24. The biliary stent of claim 23 wherein the ridges and valley disposed in partial circumferential segments have a helical orientation relative to a longitudinal axis of the stent.

25. The biliary stent of claim 24 further comprising at least one marker band located adjacent at least one end of the stent.

26. The biliary stent of claim 24 further comprising a proximal end and a distal end wherein the ends are free of ridges and valleys.

27. The biliary stent of claim 18 further comprising a proximal end and a distal end wherein the ridges and valleys are disposed on at least one of the ends.

- 11 -

28. The biliary stent of claim 18 further comprising a proximal end and a distal end wherein the ridges and valleys are disposed in close proximity to at least one end.

29. The biliary stent of claim 18 further comprising at least one marker band located adjacent to at least one end of the stent.

30. The biliary stent of claim 18 further comprising a proximal end and a distal end wherein the ends are free of ridges and valleys.

31. The biliary stent of claim 18 further comprising a proximal end and a distal end wherein at least one of the ends has an elongate inlet opening.

32. The biliary stent of claim 31 wherein the distal end of the stent is beveled.

33. A method for making a stent comprising:
providing a thermoplastic tube, and
forming circumferentially extending ridges and valleys about the external surface of the tube.

34. The method of claim 33 further comprising:
rotating the thermoplastic tube; and
placing a thermoforming tool against a sidewall of the tube.

35. The method of claim 34 further comprising:
advancing the thermoforming tool along the length of the tube to form ridges and valleys that define a helical configuration.

- 12 -

36. The method of claim 35 further comprising:
supporting the tube on a mandrel having an outside diameter less than an inside diameter of the tube.

37. The method of claim 36 further comprising:
cyclically applying and removing the thermoforming tool while the tube is rotated.

38. The method of claim 33 further comprising supporting the tube on a mandrel and heat molding the outer surface of the tube while on the mandrel.

39. The method of claim 37 wherein the outer diameter of the mandrel is smaller than the inner diameter of the tube.

40. A method for stenting a duct in the biliary tree comprising:
providing a stent having ridges and valleys at least partially along an outer surface of the stent and a delivery device for delivering the stent into the biliary tree;
advancing the delivery device with the stent mounted on the delivery device toward the intended site of deployment; and, while so advancing the stent, selectively pushing or rotating the stent.

41. The method of claim 40 further comprising:
gripping the stent securely at its proximal end during advancement.

42. The method of claim 40 further comprising preliminarily selecting a stent having ridges and valleys of a selected pitch and depth.

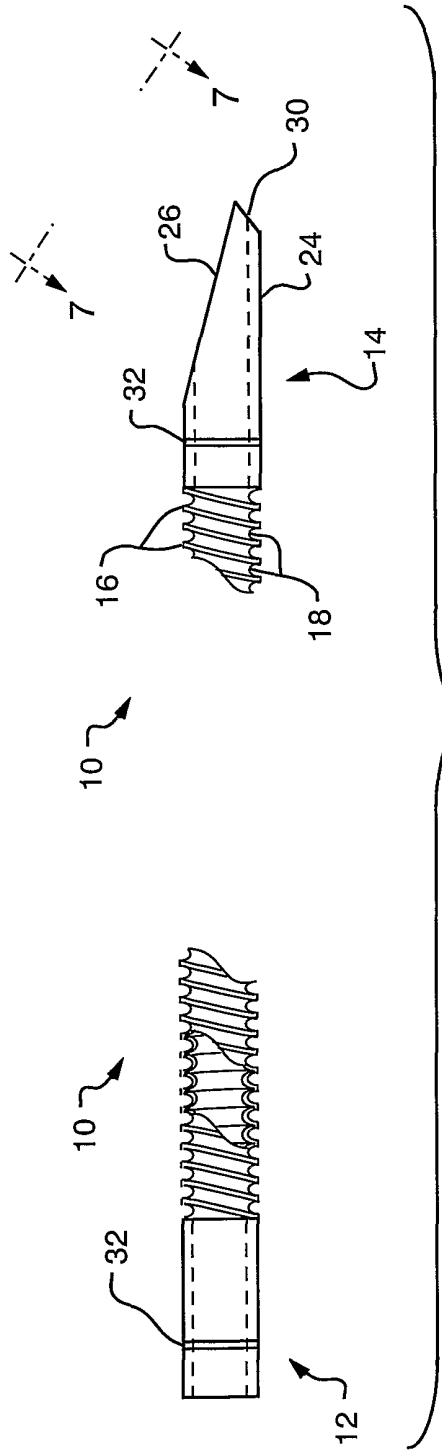

FIG. 1

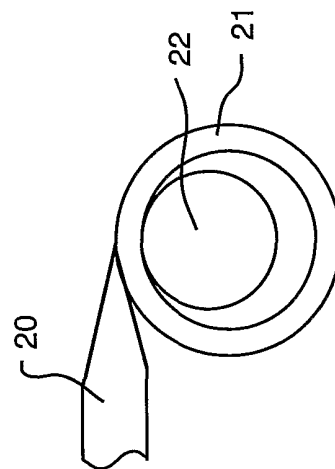

FIG. 6

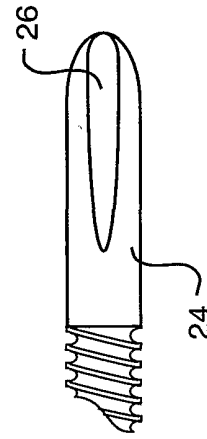

FIG. 7

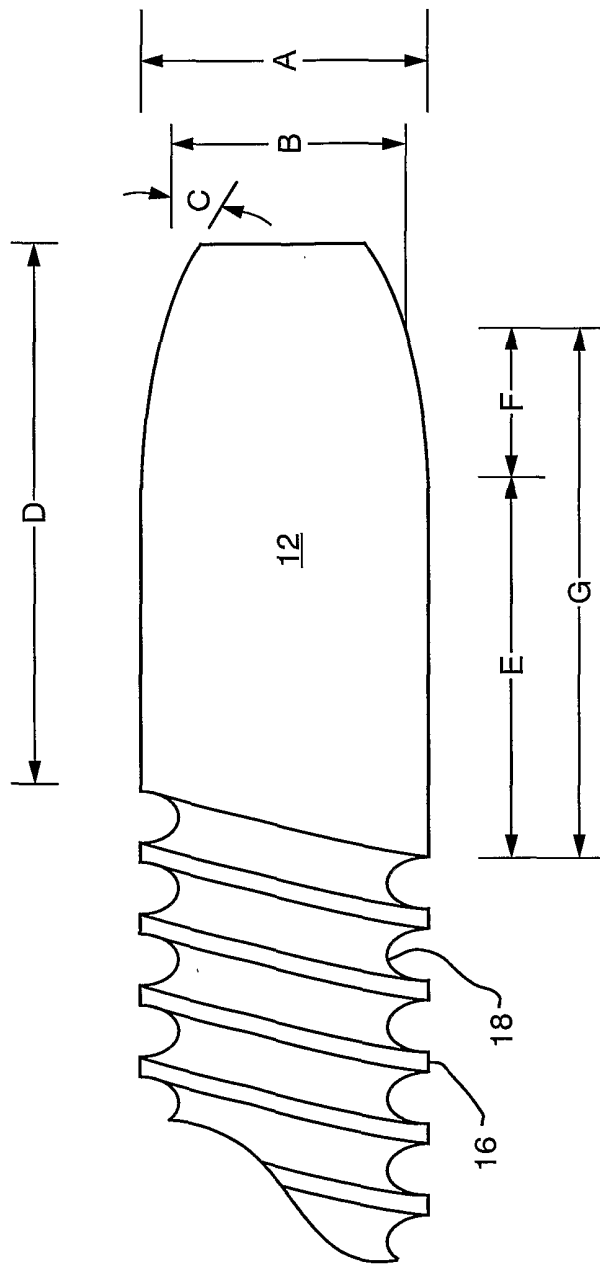

FIG. 2

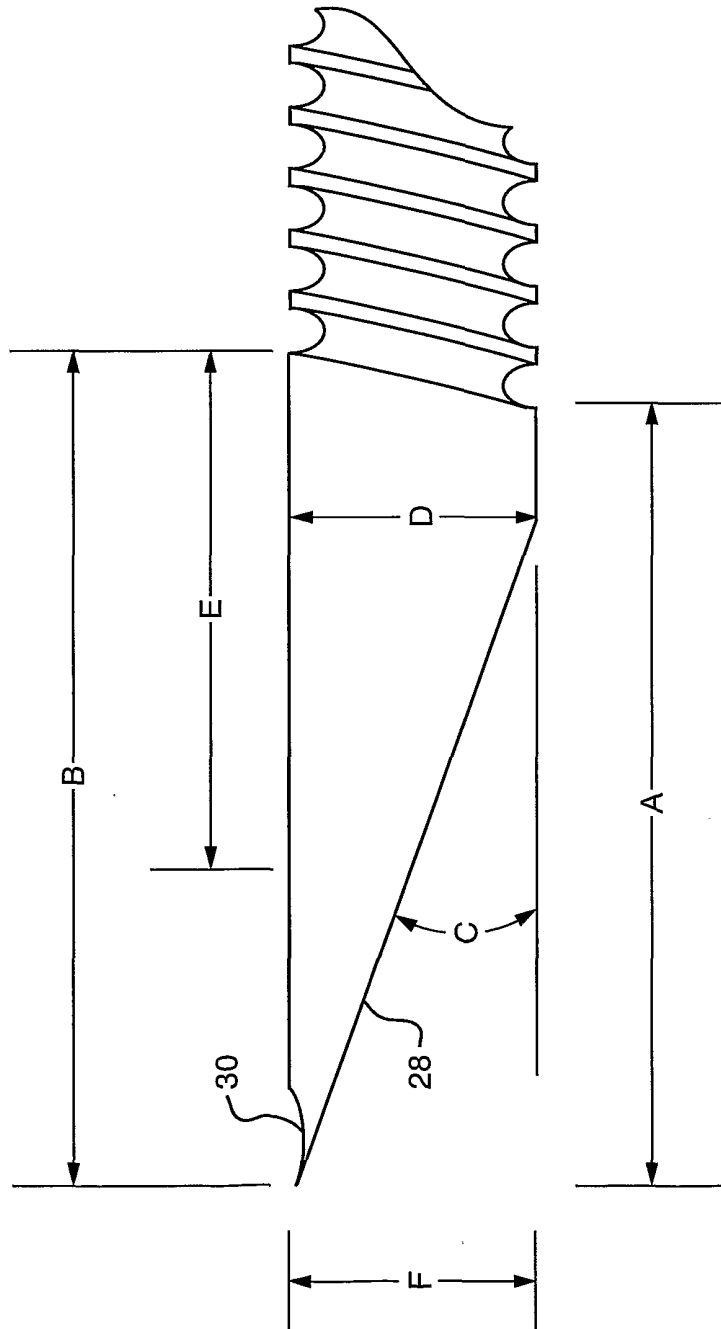

FIG. 3

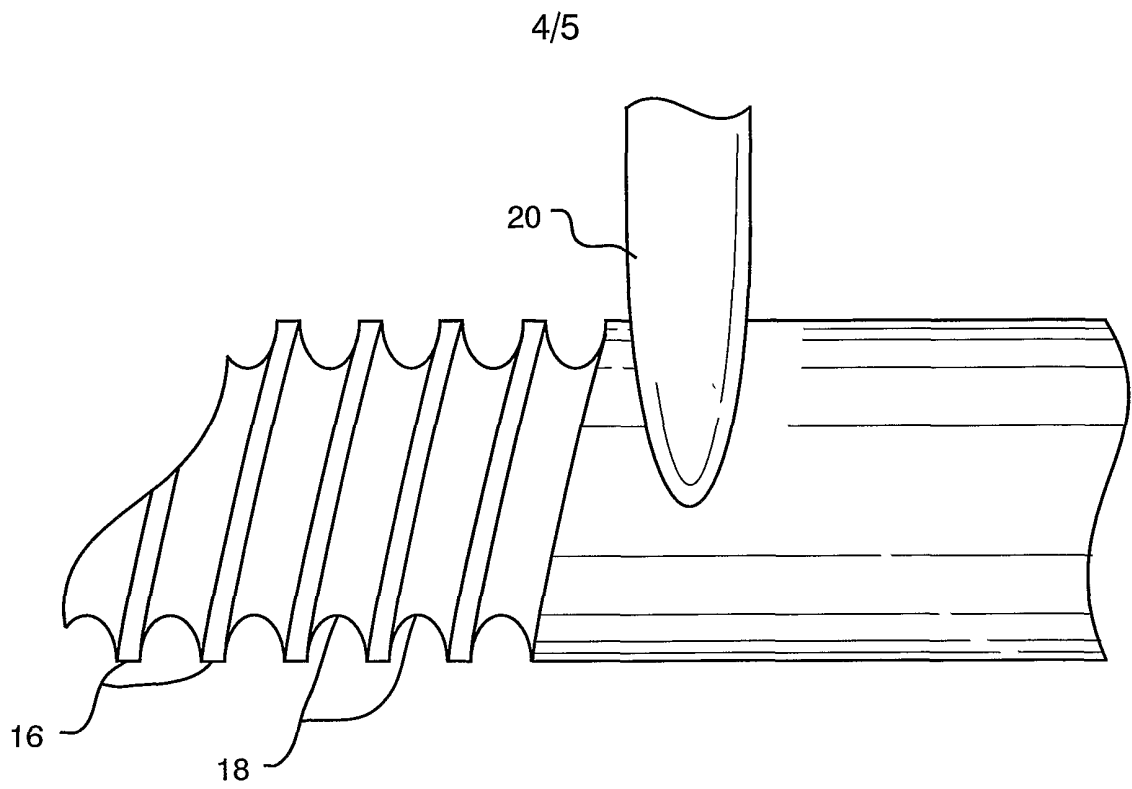

FIG. 4

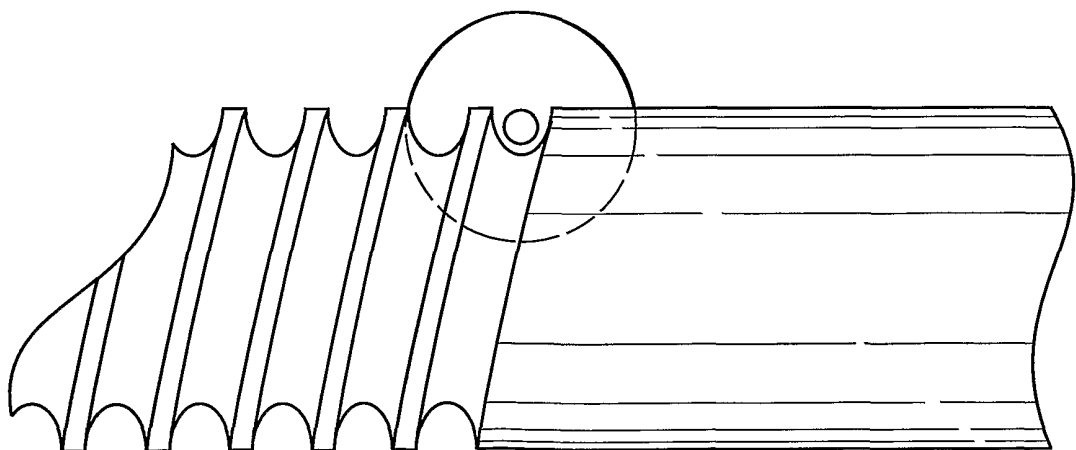

FIG. 5

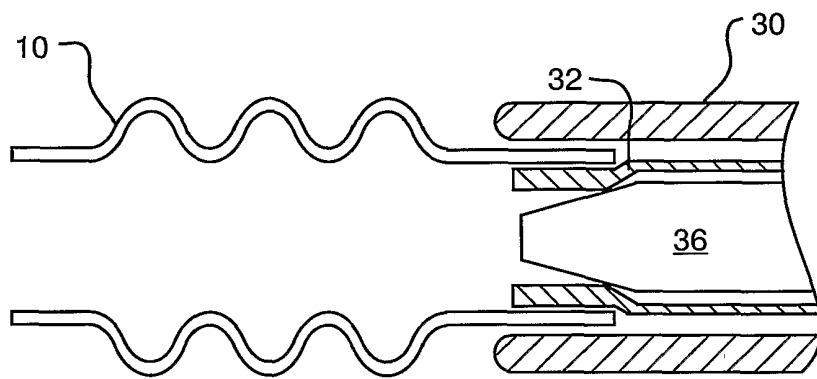
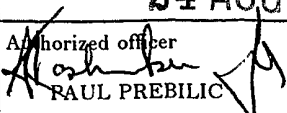

FIG. 8

INTERNATIONAL SEARCH REPORT

International application No.
PCT/US01/16132

A. CLASSIFICATION OF SUBJECT MATTER IPC(7) :A61F 2/06 US CL :623/1.15 According to International Patent Classification (IPC) or to both national classification and IPC		
B. FIELDS SEARCHED Minimum documentation searched (classification system followed by classification symbols) U.S. : 623/1.15, 1.22, 1.28, 1.34, 1.37, 23.7, 23.70; 604/9; 606/198; 264/310, 323 Documentation searched other than minimum documentation to the extent that such documents are included in the fields searched Electronic data base consulted during the international search (name of data base and, where practicable, search terms used) Please See Extra Sheet.		
C. DOCUMENTS CONSIDERED TO BE RELEVANT		
Category*	Citation of document, with indication, where appropriate, of the relevant passages	Relevant to claim No.
X ----- Y	US 5,984,695 A (KNAPP et al) 16 November 1999, see the entire document.	1-5, 10, 12-16, 18-22, 27-33 ----- 40-42
X	US 3,105,492 A (JECKEL) 01 October 1958, see the entire document.	33 and 38
X	US 5,129,910 A (PHAN et al) 14 July 1992, see the entire document.	1-16, 18-23, and 27-33
<input type="checkbox"/> Further documents are listed in the continuation of Box C. <input type="checkbox"/> See patent family annex.		
* Special categories of cited documents: "A" document defining the general state of the art which is not considered to be of particular relevance "E" earlier document published on or after the international filing date "L" document which may throw doubts on priority claim(s) or which is cited to establish the publication date of another citation or other special reason (as specified) "O" document referring to an oral disclosure, use, exhibition or other means "P" document published prior to the international filing date but later than the priority date claimed	"T" later document published after the international filing date or priority date and not in conflict with the application but cited to understand the principle or theory underlying the invention "X" document of particular relevance; the claimed invention cannot be considered novel or cannot be considered to involve an inventive step when the document is taken alone "Y" document of particular relevance; the claimed invention cannot be considered to involve an inventive step when the document is combined with one or more other such documents, such combination being obvious to a person skilled in the art "&" document member of the same patent family	
Date of the actual completion of the international search 12 JULY 2001		Date of mailing of the international search report 24 AUG 2001
Name and mailing address of the ISA/US Commissioner of Patents and Trademarks Box PCT Washington, D.C. 20231 Facsimile No. (703) 305-3230		Authorized officer  RAUL PREBILIC Telephone No. (703) 308-0858

INTERNATIONAL SEARCH REPORT

International application No.

PCT/US01/16132

B. FIELDS SEARCHED

Electronic data bases consulted (Name of data base and where practicable terms used):

WEST 2.0 search terms "(biliary or bile) same stent and (ridges or pleats of corrugations)"

EAST 1.02.0008 search terms "(tube or tubular or cylinder or cylindrical) same termoform\$ with tool"