

F. WUTERICH.
Cigar Machine.

No. 31,002.

Patented Dec. 18, 1860.

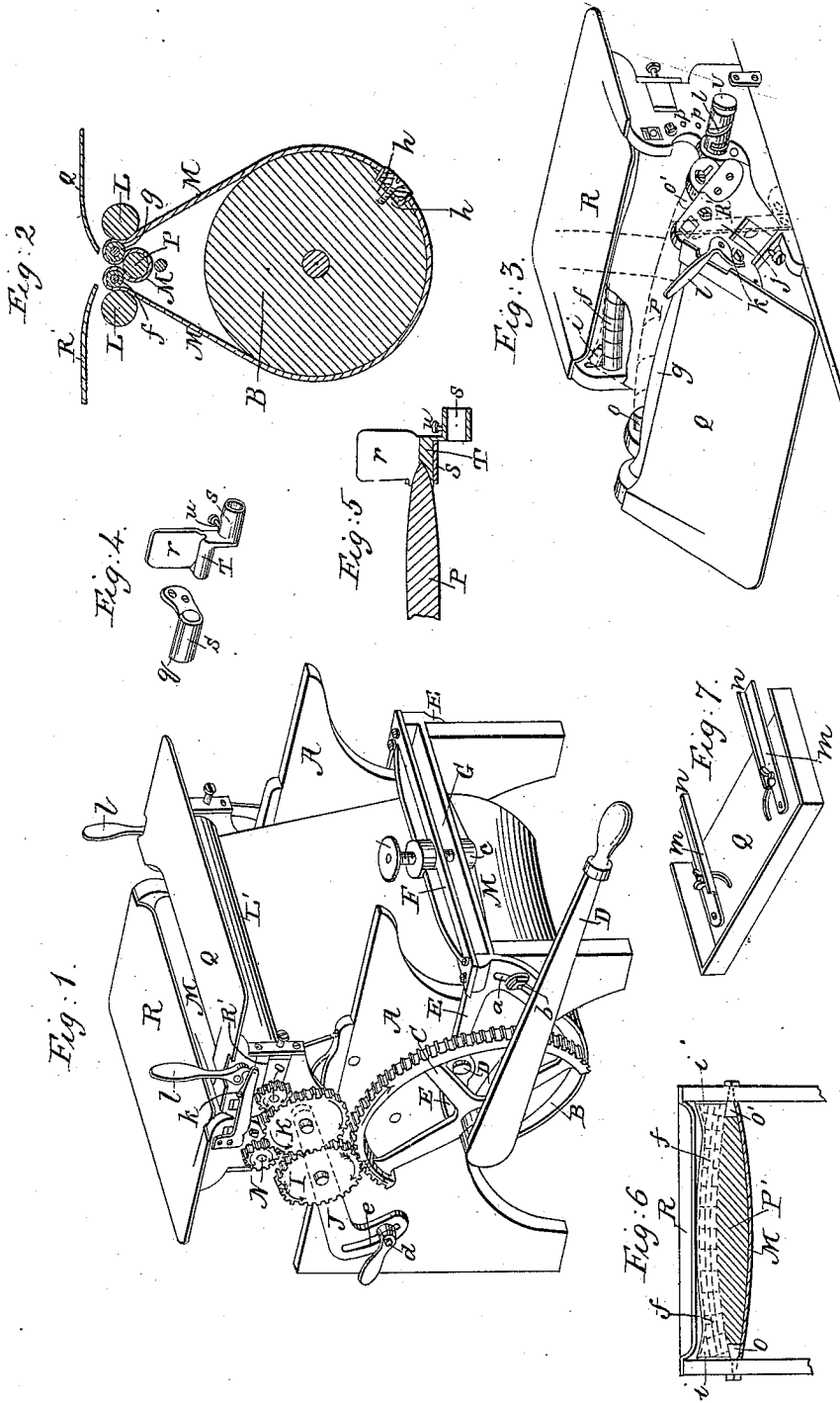

Witnesses
E. Cohen
Ch. F. Wuterich

Inventor
Ferdinand Wuterich
by atty A. P. Slaughter

UNITED STATES PATENT OFFICE.

FERDINAND WUTERICH, OF NEW YORK, N. Y., ASSIGNOR TO HIMSELF AND JOHN M. HATHAWAY, OF SAME PLACE.

IMPROVEMENT IN MACHINES FOR MAKING CIGARS.

Specification forming part of Letters Patent No. 31,002, dated December 18, 1860.

To all whom it may concern:

Be it known that I, FERDINAND WUTERICH, of the city, county, and State of New York, have invented certain new and useful Improvements in Machines for Making Cigars; and I do hereby declare the following to be a full, clear, and exact description of the same, reference being had to the accompanying drawings, making a part of this specification, in which—

Figure 1 represents a perspective view of the machine. Fig. 2 represents a vertical cross-section through the rolls and belt and the cigar when being made. Fig. 3 represents in perspective a portion of the machine as thrown open to receive the tobacco. Figs. 4, 5, 6, and 7 represent details of the machine that will be hereinafter more particularly referred to.

Similar letters of reference, where they occur in the separate figures, denote like parts of the machine in all the drawings.

My invention relates to a machine for making cigars by rolling them up between a peculiarly-operated elastic belt and rollers, and in pointing the cigar by a mechanism to which motion is given from one of the moving parts of the machine, all of which will be hereinafter explained.

To enable others skilled in the art to make and use my invention, I will proceed to describe the same with reference to the drawings.

A A represent a frame in which is hung the journals of a large concave cylinder, B. On one of these journals is affixed a cogged segment, C, and also a hand-lever, D, by which the machine may be operated. I do not, however, restrict my invention to this mode of operating it, as other machinery may be applied. The cylinder B is not directly hung in the main frame, but hung to it by means of lever-arms E, pivoted to the main frame, as at D', and extending toward one end of the machine, where the two levers are connected by a cross-head, F. The extreme ends of the levers E have curved slots *a* in them, through which set-screws *b* pass into the main frame for holding said levers, and consequently the cylinder B in place, when adjusted properly. The cross-head F stands over the cross-piece G of the main frame, and a set-screw, H, pass-

ing through the cross-head, and its end working in a nut, *c*, on the cross-piece G, enables the attendant to raise or lower the cylinder B, as may be required, to slacken or tighten the belt attached to said cylinder, for a purpose that will be hereinafter explained. The segment-wheel C gears with and turns a cogged wheel, I, that is hung in adjusting-levers J, said adjusting-levers having their fulcras on the shaft or journals of the wheel K and extending toward the end of the frame, where they are held by a set-screw, *d*, passing through a curved slot, *e*. The wheel K gears with the cog-wheel I, and receives its motion from the wheel I. The object of hanging the wheel I in the levers or arms J, that move on the center of the shaft that carries the cog-wheel K, is that I and K shall continue in gear with each other, when the one I is raised or lowered to correspond with the segment C when it is raised or lowered to slacken or tighten the belt M, attached to the drum on the shaft of the segment C. The cog-wheel K gears with and turns the two pinions N O, which are respectively placed on the rolls L L', which pinch the belt M up to and against the forming-rolls *f g*, as seen in Fig. 2. When the segment C is turned in the direction of the black arrow shown upon it, the cog-wheels I K N O, with their respective shafts or journals, rotate in the direction shown by the black arrows upon them; and when the segment C is moved in the direction of the red arrow then the several parts turned by it move in the directions shown by their red arrows. The belt M always moves in the direction that the segment moves in for the time being. The belt M is not an endless belt, for its drum or cylinder cannot make a full revolution. The two ends of the belt, after being passed over and around the several rolls, as shown in Fig. 2, are secured to the concave drum or cylinder B, as shown at *h*, though, instead of the strip and groove, as therein shown, two shafts may be fixed in the groove or to the cylinder, to which the ends of the belt may be attached, and these shafts may be geared together, so that by turning them the ends may be drawn up or slackened to adjust the belt to the proper tension, a dog and ratchet holding the rolls when the adjustment is made. This taking up or adjusting of the belt would avoid

the necessity of making the cylinder itself adjustable, as above described, as also of adjusting the gear I to it. The object in having some convenient adjustment is not only to take up the stretch of the belt itself, but to allow it to bag properly where the cigar P is being rolled, so as to give it the desired shape.

I have described and shown the cylinder B as being concave, the object of which is to form the bag where the cigar is made of the shape of the cigar itself—a parabolic spindle. To complete a bag of this shape, however, requires more than the belt itself. The forming-rolls *f g* are arched in a segment of a parabola, and they form the upper portion of the chamber in which the cigar is rolled into its proper shape. The forming-rolls *f g* are made of a series of sleeves strung upon a shaft, as shown in Figs. 3, 6, so that when greater pressure comes upon one portion of the roll than upon others the segments or sleeves may yield to it without requiring slip-motion upon either pressing-surface, and being thus made, too, enables me to use segments or sleeves of greater or less diameter, to change the size of the cigar to be made. A belt passing around a concave cylinder like that at B, and thence over arched forming-rollers *f g*, would crimp or crawl up toward the crown of the arches, because of its pinching tightest at those points and its consequent slackness at the edges. To avoid this, and to keep the belt perfectly smooth, particularly as or where it passes over the arched forming-rolls, I place conical belt-catchers *i* in the spandrels of the arches, which take up all the slack of the belt, and more too, for they hold it so tight at the edges that the tendency of the belt is to run up onto the cones, and thus draw it smooth over the arched rollers *f g*, it being the tendency of a belt to always move toward the point on the drum or rolls where it pinches or binds tightest.

Q R are tables upon which the tobacco is placed out of which the cigars are to be made. I have shown one only of said tables Q as being hinged, so as to open down the chamber for the receipt of the charge of tobacco. Both of course may be hinged, so that the operator may stand on either side of the machine, or so that two persons may work at the machine, the one making a cigar, while the other is selecting the proper charge of tobacco for the next one to be made, and so on alternately. The table Q and its frame R' must be hinged to the journal or shaft of the cog-wheel K, because the pinion *o* is hung to said frame, and this will allow said pinion to roll over the cog-wheel K without running out of gear with it.

j are spring-hooks, which take over catches *k*, to hold the table up to its proper place when the cigar is being made, and *l* are trip-levers that throw the hooks off from their catches when the table is to be dropped down to put in the charge of tobacco or to take out the finished cigar.

In Fig. 7 I have shown a form of table which

I propose to use. It has adjustable strips *m n* upon it, which may be set at their ends *n n* to conform to the length of the cigar that is to be made, or to the exact spot in the bag of the belt where the charge of tobacco is to be dropped, or both, and give uniformity of shape and length to the cigars. The lever D may be placed at either end of the machine, or there may be one at each end, one extending toward one table and the other to the other table, and the cigars may be rolled up into its wrapper "left handed" or "right handed," as it is termed (both being used in making cigars)—that is, with the edges of the wrappers run to the right or to the left, just as the machine may be moved.

There are several adjustments to the parts of this machine which I do not propose to describe in detail, as it would make the description too long, and as they are shown; but they all add to the perfect and harmonious action of the individual parts as a whole, and are hence important. The charge of tobacco being dropped into the forming-chamber or bag of the belt and the table closed up tight, motion is given to the belt B, and the wrapper having been properly introduced also, the tobacco is rolled up into the wrapper and the cigar receives the shape of the space inclosed between the bag and the rolls *f g*. After the first wrapper is put on, a second one may afterward be wound over the first one. At the ends of the chamber where the cigar is formed are conical rollers *o o'*, whose apices are reversed from those *i i*. The belt passes over those *i* and under those *o*, for the purpose of keeping the belt down at the edges, and leaving a proper space for the ends of the cigar to be formed in, as shown more particularly in Fig. 6, and those *o* also prevent the bag from flying up when the machine is opened to take out the cigar or recharge it with tobacco. By shifting these conical rollers or guides the size of the ends of the cigar may be varied. To make the ends of the cigar small, they should be raised up. This makes the belt tighter at the edges, while the middle remains the same, thus making the cigar large in the center and smaller at the ends; or, if it is desirable, to have one end only small, then the cones on one side may be raised higher than those on the other side. When a number of cigars have thus been made, and are to be tipped or finished, the end piece, *o'*, is removed, and a guide-piece, S, Fig. 4, takes its place, though fastened to the opposite side of the frame, as at *p p*. Along this guide-piece there is a slot, *q*, into which an arm, *r*, on the tip-former T is slipped, and at the same time the sleeve or ferrule *s* is slipped over the end of the shaft U, (the shaft on which the gear K is fixed,) said shaft having a screw-thread or worm, *t*, formed in it, into which a screw stem or point, *u*, in the sleeve *s* is placed and works, so that the turning of the shaft U runs the tip-former T up against the cigar-tip, as shown in Fig. 5, and forms and smooths the tip, and then the

reverse motion runs it back again. The second wrapper may be put onto the cigar while it is being tipped.

Having thus fully described my invention, what I claim therein as new, and desire to secure by Letters Patent, is—

1. In cigar-making machines, the combination of a concave cylinder to which the two ends of the belt are fastened, and the arched forming-rollers and conical belt-stretchers, substantially as and for the purpose described.

2. Making the arched forming-rollers of a series of segments or sleeves that can move independent of each other, so as to accommodate itself to the different pressure on different parts of the belt, substantially as described.

3. The pointing and finishing mechanism S T, when operated substantially as described.

4. The conical guides and rolls *i* and *o*, for the purpose of keeping the belt in proper position at its edges and for adjusting the same when necessary, substantially as described.

5. Forming a chamber in which a cigar of ordinary shape may be rolled up into form by means of a bag in an elastic belt, and two arched rollers, substantially as herein described, not meaning to lay any claim to the belt or the bag formed therein when used separately from the arched rollers.

FERDINAND WUTERICH.

Witnesses:

E. R. SLOSSON,
LOUIS BASELER.