



(11) **EP 4 579 695 A1**

(12) **EUROPEAN PATENT APPLICATION**

(43) Date of publication:  
**02.07.2025 Bulletin 2025/27**

(51) International Patent Classification (IPC):  
**H01F 7/02** <sup>(2006.01)</sup> **H01F 1/00** <sup>(2006.01)</sup>  
**H01F 41/02** <sup>(2006.01)</sup>

(21) Application number: **23220689.6**

(52) Cooperative Patent Classification (CPC):  
**H01F 41/0273; H01F 1/0081; H01F 7/0273**

(22) Date of filing: **29.12.2023**

(84) Designated Contracting States:  
**AL AT BE BG CH CY CZ DE DK EE ES FI FR GB GR HR HU IE IS IT LI LT LU LV MC ME MK MT NL NO PL PT RO RS SE SI SK SM TR**  
Designated Extension States:  
**BA**  
Designated Validation States:  
**KH MA MD TN**

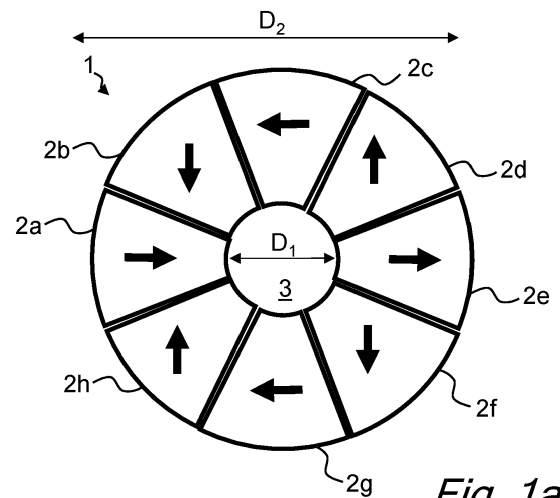
(72) Inventors:  
• **KÁDÁR, Roland**  
**436 40 Askim (SE)**  
• **GHAL, Viney**  
**415 14 Göteborg (SE)**

(74) Representative: **Aldridge, Henry Alexander Venner Shipley LLP**  
**200 Aldersgate**  
**London EC1A 4HD (GB)**

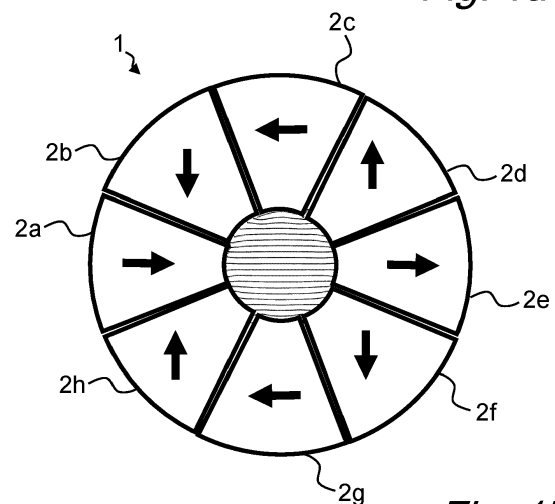
(71) Applicant: **Wellspect AB**  
**431 21 Mölndal (SE)**

(54) **METHOD FOR ORIENTING ANISOTROPIC PARTICLES USING HALBACH MAGNET ARRAY**

(57) The present disclosure relates to a method and apparatus for aligning micro- or nanoparticles. The method comprises providing a sample of a composite material, the composite material comprising a matrix material with micro- or nanoparticles and providing a cylindrical Halbach array of magnets, the cylindrical Halbach array comprising a plurality of separate magnets arranged concentrically around a central space. The method further comprises arranging the composite material sample inside the central space of the cylindrical Halbach array to align the micro- or nanoparticles and removing the composite material sample from the central space.



*Fig. 1a*



*Fig. 1b*

**EP 4 579 695 A1**

## Description

### TECHNICAL FIELD OF THE INVENTION

**[0001]** The present invention relates to a method orienting anisotropic particles in a matrix material using a Halbach array.

### BACKGROUND OF THE INVENTION

**[0002]** In various applications, it is desirable to align nanoparticles in specific orientations to achieve certain desirable material properties such as antibacterial properties, electric or thermal properties or structural properties such as increased material strength. For example, graphene flakes are one example of nanoparticles which may be added to a matrix material and then aligned to achieve e.g. increased electrical conductivity along the alignment axis.

**[0003]** Recently, considerable effort has been dedicated to orienting 1D and 2D nanomaterials to create materials with new and unique properties. Generally, there are three main approaches for achieving nanoparticle orientation: (1) through shear flow, (2) via an electric field, and (3) by utilizing a magnetic field. A benefit of using magnetic fields to align nanoparticles is that the versatility of magnetic fields allows for the sweeping alignment of nanoparticles at a large scale along tailored directions.

**[0004]** In existing solutions, two types of magnetic field systems have been employed for nanoparticle orientation, namely systems using permanent magnets and systems using electromagnets. However, the utilization of electromagnets comes with challenges due to the intricate control of high-voltage electric currents and other associated drawbacks. As a result, the use of permanent magnets, either in single or dual magnet configurations, has become a preferred choice for orienting nanoparticles. Notably, while a static alignment mode with a single or dual magnet configuration effectively aligns 1D nanomaterials, the same approach falls short for 2D nanomaterials due to their increased degrees of freedom.

**[0005]** Additionally, a rotational magnetic field generated by a dual magnet configuration has also been proposed. However, a significant challenge persists in the inherent nonuniformity of the magnetic field even in dual magnet systems. This nonuniformity hampers the desired uniform alignment of nanoparticles, presenting a bottleneck in realizing the full potential of oriented nanoparticle systems.

**[0006]** Accordingly, there is a need for a new method for aligning nanoparticles which at least partially overcomes the drawbacks of the previous solutions.

### SUMMARY OF THE INVENTION

**[0007]** It is a purpose of the present invention to over-

come at least some of the drawbacks associated with existing methods for aligning nanoparticles and/or larger particles, such as microparticles.

**[0008]** According to a first aspect of the invention there is provided a method for aligning micro- or nanoparticles in a matrix material. The method comprises providing a sample of a composite material, the composite material comprising matrix material with micro- or nanoparticles, and providing a cylindrical Halbach array of magnets, the cylindrical Halbach array comprising a plurality of separate magnets arranged symmetrically around a central space. The method further comprises arranging the composite material sample inside the central space of the concentric Halbach array to align the micro- or nanoparticles and removing the composite material sample from the central space.

**[0009]** Since the axisymmetric cylindrical Halbach array (sometimes referred to as a Halbach cylinder) provides a strong and uniform magnetic field, the alignment of the micro- or nanoparticles will be much more homogenous compared to when alignment is achieved using single magnet or double magnet arrangements. By comparison, when the cylindrical Halbach array is used to align the micro- or nanoparticles a larger portion of the micro- or nanoparticles will become linearly aligned and/or the micro- or nanoparticles will align much more rapidly due to the inherently strong magnetic field generated by the cylindrical Halbach array. It has been found that alignment with a Halbach array enables e.g. the desirable material properties of composite materials with aligned micro- or nanoparticles to be achieved with less micro- or nanoparticles added to the composite material and/or that the desirable properties will be much more pronounced. For example, aligned micro- or nanoparticles have shown to form an antibacterial surface and it has been found that by using the cylindrical Halbach array to align the micro- or nanoparticles, compared to using a double-magnet arrangement, the antibacterial properties are more pronounced even when the concentration of micro- or nanoparticles in the matrix is halved.

**[0010]** With nanoparticles and microparticles it is meant particles ranging from the nanoscale to the micro-scale. Nanoparticles include any particle which is smaller than 500 nm in at least one dimension, and preferably smaller than 100 nm in at least one dimension. Nanoparticles may also include 3D nanoparticles that form structures larger than 100 nm or 500 nm in all three dimensions. Microparticles include any particle which is smaller than 500  $\mu\text{m}$  in at least one dimension, and preferably smaller than 100  $\mu\text{m}$  in at least one dimension.

**[0011]** In some implementations, the micro- or nanoparticles are anisotropic.

**[0012]** In some implementations, the micro- or nanoparticles exhibits a shape anisotropy and are oblate or prolate particles.

**[0013]** In some implementations, the micro- or nanoparticles are paramagnetic, ferromagnetic or ferrimagnetic.

**[0014]** By utilizing magnetically active micro- or nanoparticles the micro- or nanoparticles will interact more strongly with the magnetic field which will contribute to a more homogenous alignment and/or rapid alignment. Some common micro- or nanoparticles, such as graphene flakes (an example of a nanoparticle), are however not inherently magnetic. To this end, the method may further comprise providing a matrix material, providing (not strongly magnetic) micro- or nanoparticles, attaching magnetic particles to the micro- or nanoparticles to make the micro- or nanoparticles magnetic and adding the magnetic micro- or nanoparticles to the matrix material.

**[0015]** Accordingly, by attaching magnetic particles to the micro- or nanoparticles, the micro- or nanoparticles (themselves only interacting weakly with the magnetic field) with magnetic particles attached, will interact more strongly with the magnetic field so as to achieve more rapid and/or highly homogenous alignment. As mentioned above, this is especially suitable for e.g. graphene, which itself only weakly interacts with the magnetic field.

**[0016]** In some implementations, the magnetic particles are attached to the micro- or nanoparticles using electrostatic adsorption and/or short-range van der Waals attractions. However, attachment using electrostatic adsorption and/or short-range van der Waals attractions is only examples and other techniques as such known by the person skilled in the art may be used. For example, hydrothermal techniques can be used to directly grow paramagnetic particles on diamagnetic particles (e.g. graphene).

**[0017]** As one example, iron oxide  $\text{Fe}_3\text{O}_4$  will attach to 2D graphene flakes using electrostatic adsorption and/or short-range van der Waals attractions. Experiments have been conducted and shown that a pH 7.0 suspension of graphene nanoflakes (with an average size of 5  $\mu\text{m}$ ) and  $\text{Fe}_3\text{O}_4$  particles (with an average size of 10 nm) leads to strong electrostatic adsorption. The electrostatic adsorption is accredited to a large difference in zeta potential of cationic  $\text{Fe}_3\text{O}_4$  and negative charge graphene nanoflakes at pH 7.0 which is +25 mV and -50 mV, respectively.

**[0018]** In some implementations, the magnetic particles are paramagnetic, ferromagnetic or ferrimagnetic particles.

**[0019]** As an example,  $\text{Fe}_3\text{O}_4$  particles are superparamagnetic. It is however envisaged that other paramagnetic particles (or ferromagnetic particles, or ferrimagnetic particles) can be attached to the micro- or nanoparticles to make them interact more strongly with the magnetic field generated by the Halbach array.

**[0020]** In some implementations, the micro- or nanoparticles comprise at least one of: cellulose fibers, nanocrystals, graphene, wood fibers, MXenes and boron nitride.

**[0021]** Many other types of micro- or nanoparticles can also be used. Preferably, the micro- or nanoparticles are anisotropic.

**[0022]** In some implementations, the cylindrical Hal-

bach array comprises magnets with a trapezoidal cross-section or magnets with a cross-section of an annulus sector.

**[0023]** It has been found that by altering the shape of each magnet (segment) the magnetic properties inside the central space varies. Magnet segments having a trapezoidal cross-section are preferred since these are easy to manufacture and provide the strongest magnetic field in the central space. Magnet segments having a cross-section of an annulus sector offer better linearity (which may be preferable in some implementations) but are in general more difficult to manufacture and provide a weaker magnetic field.

**[0024]** Each magnet segment may be realized with a permanent magnet or an electromagnet. For example, it is envisaged that all magnet segments are permanent magnets, that all magnet segments are electromagnets or that the cylindrical Halbach array is made of a mix of permanent magnets and electromagnets.

**[0025]** A permanent magnet segment may be made with any suitable magnetic material. For example permanent neodymium magnets, permanent samarium-cobalt magnets and/or permanent ferrite magnets may be used.

**[0026]** A benefit of using electromagnet segments is that the magnetic field strength can be dynamically adjusted. For example, the electromagnets of the Halbach array can be controlled to provide a magnetic field strength inside the central space which varies over time. Also, depending on the type of micro- or nanoparticle and/or the matrix material of the composite material, the magnetic field strength can be adjusted accordingly to achieve alignment.

**[0027]** In some implementations, the magnets of the cylindrical Halbach array are arranged in direct contact with each other. This is especially beneficial for permanent magnet segments as it has been found that contacting permanent magnets provide a stronger magnetic field.

**[0028]** For many cross-sectional shapes of the magnet segments (including the trapezoidal shape and annulus sector shape) it has been found that arrangement of the segments in direct contact with each other further increases the magnetic field strength compared to arranging the segments with an air gap or dielectric membrane separating the segments. To this end, it is envisaged that the segments are placed in contact with each other to provide more homogenous and/or rapid alignment of the micro- or nanoparticles.

**[0029]** In some implementations, the Halbach array comprises an inner cylindrical Halbach array with N segments and an outer cylindrical Halbach array with M segments, wherein  $M > N$ . Preferably,  $N \geq 2$ . The two cylindrical Halbach arrays are arranged concentrically and, with two or more concentric Halbach arrays, the magnetic field strength inside the central space of the innermost Halbach array is increased. In general more than two concentric Halbach arrays can be used, with

each array comprising a greater number of segments compared to its neighboring inner array.

**[0030]** In some implementations, the cylindrical Halbach array extends along a central axis, and the method further comprises rotating, around the central axis, at least one of the cylindrical Halbach array and the composite sample relative the other one of the Halbach array and the composite sample, so as to align the micro- or nanoparticles with a magnetic field which rotates relative the composite sample.

**[0031]** For some types of micro- or nanoparticles (and in particular for 2D nanoparticles or 3D nanoparticles) it has been found that a rotating magnetic field will achieve better alignment results compared to using a static magnetic field. Since the Halbach array is axisymmetric around the central space it can be rotated around the composite sample to provide a rotating magnetic field. Additionally, or alternatively, the composite sample can be rotated inside the central space of the cylindrical Halbach array to realize a magnetic field which rotates relative to the frame of reference fixed to the composite material.

**[0032]** In some implementations, the method further comprises linearly displacing the composite sample relative the cylindrical Halbach array along the central axis.

**[0033]** That is, the magnetic alignment may be performed as a part of an inline process wherein composite material is fed through the central space of the cylindrical Halbach array. For example, the composite material is formed in an extrusion process and the cylindrical Halbach array is arranged in-line with the extruder.

**[0034]** In some implementations, the cylindrical Halbach array is split into two half portions along a radial direction such that each half portion comprises at least one magnet and wherein the composite sample is in a planar shape, e.g. in the form of a sheet material. Wherein the method further comprises displacing the planar shaped sheet composite material relative the two half-portions of the cylindrical Halbach array such that the planar composite material moves through a gap between the two half-portions and through the central space.

**[0035]** By comparison, moving the composite material through the central space of the cylindrical Halbach array, along the central axis, may put strict limits on the dimensions of the composite material in at least two dimensions. For instance, inline processing wherein the composite material is fed along the central axis through the central space may be well suited for a composite material that is elongated, having a width and thickness that is smaller compared to its length. On the other hand, by utilizing a split Halbach array having a gap, the Halbach array can be used to process composite materials of planar shape (such as composite materials shaped like sheets or composite materials in the form of coatings applied to a planar substrate. As the planar composite material passes through the gap and the central space of the split Halbach array it will be exposed to a strong and linear magnetic field which aligns the micro- or nanopar-

ticles.

**[0036]** Accordingly, the Halbach array can be used to process both composite materials arranged forming elongated bodies and planar-shaped composite materials. A single-piece Halbach array may be preferred for elongated bodies and a two-part Halbach array may be preferred for larger, planar, composite materials. However, since the size and dimensions of both the single-piece Halbach array and the two-part Halbach array can be varied either type of Halbach can in general be used for any shape of the composite material.

**[0037]** In some implementations, the method further comprises rotating each half-portion of the two-part Halbach array around a common rotational axis that is parallel to the surface normal of the planar composite material or the substrate onto which the composite material has been applied as a coating. Accordingly, it is possible to apply a rotating magnetic field to planar composite material or composite material coating to align the micro- or nanoparticles with a rotating magnetic field.

**[0038]** In some implementations, the method further comprises heating the composite material prior to it being arranged in the central space of the cylindrical Halbach array, and/or cooling, heat curing or light curing the composite material after it has been removed from the central space.

**[0039]** Heating the composite material prior to (or at the same time as) the composite material is fed through the central space is beneficial since the matrix may melt and/or exhibit decreased viscosity, which makes it easier for the micro- or nanoparticles to realign when exposed to the magnetic field.

**[0040]** Additionally or alternatively, cooling the composite material after exposure to the magnetic field may have the benefit of causing the matrix to solidify which locks the alignment of the micro- or nanoparticles in place at the aligned position. Heating the matrix prior to feeding through the central space and/or cooling the matrix after it has passed the central space is especially beneficial for matrices made of a thermoplastic material. Working in high temperature environments may require active cooling of the magnets to preserve the magnetic field intensity.

**[0041]** In some implementations, the matrix is curable by a crosslinking reaction initiated by e.g. heat, moisture or light exposure. For example, the matrix is a resin curable by light (e.g. UV) or heat and by exposing the composite material (after having passed the cylindrical Halbach array) to curing light or curing heat the matrix cures and locks the aligned micro- or nanoparticles in their aligned position. The curing process may be in direct connection with the alignment by the Halbach array, or it may be performed in a separate process step.

**[0042]** In some implementations, the micro- or nanoparticles are nanoparticles. Such as 0D nanoparticles, 1D nanoparticles, 2D nanoparticles or 3D nanoparticles. In some implementations, the nanoparticles are 0D nanoparticles, 1D nanoparticles or 2D nanoparticles.

**[0043]** In some implementations, the cylindrical Halbach array of magnets comprise at least eight separate magnet segments arranged concentrically around the central space.

**[0044]** By providing more segments, the magnetic field strength inside the central space can be increased and/or the linearity/uniformity of the magnetic field improved. However, using more segments also makes the manufacturing of the Halbach array more complicated. It has been found that as few as four segments achieve excellent linearity and strong magnetic fields, but the linearity and magnetic field strength can further be enhanced if more segments are used.

**[0045]** In some implementations, the Halbach array comprises between four and sixteen segments with optional outer Halbach subarrays comprising additional segments and/or an additional inner subarray comprising two segments.

**[0046]** In general, when the composite material is exposed to static magnetic field more segments (such as six, eight or more) are preferred compared to when the magnetic field is rotating (wherein as few as three or, preferably, four segments could suffice).

**[0047]** According to a second aspect of the invention, there is provided an apparatus for aligning micro- or nanoparticles in a matrix material. The apparatus comprises a sample holder, configured to hold a sample of a composite material, the composite material comprising the matrix material with randomly oriented micro- or nanoparticles, a concentric Halbach array of magnets, the cylindrical Halbach array comprising a plurality of separate magnets arranged concentrically around a central space, and an actuator to provide a relative movement between the sample holder and the Halbach array, to bring the composite material sample into and out from the central space of the cylindrical Halbach array.

**[0048]** The invention according to the second aspect features the same or equivalent benefits as the invention according to the first aspect. Any functions described in relation to the method, may have corresponding features in a manufacturing system or vice versa.

**[0049]** Such and other obvious modifications must be considered to be within the scope of the present invention, as it is defined by the appended claims. It should be noted that the above-mentioned embodiments illustrate rather than limit the invention, and that those skilled in the art will be able to design many alternative embodiments without departing from the scope of the appended claims. In the claims, any reference signs placed between parentheses shall not be construed as limiting to the claim. The word "comprising" does not exclude the presence of other elements or steps than those listed in the claim. The word "a" or "an" preceding an element does not exclude the presence of a plurality of such elements.

#### BRIEF DESCRIPTION OF THE DRAWINGS

**[0050]** The present invention will be described in more

detail with reference to the appended drawings, showing currently preferred embodiments of the invention.

Figures 1a-b show a cross-sectional view of a cylindrical Halbach array according to some implementations.

Figures 2a-d show cross-sectional views of some exemplary types of segments that can be used to form a cylindrical Halbach array.

Figure 3 is a flowchart illustrating a method for aligning micro- or nanoparticles with a cylindrical Halbach array 1 according to some implementations.

Figures 4a-f illustrate a composite material comprising a matrix and micro- or nanoparticles with different types of alignment.

Figures 5a-b illustrate a manufacturing setup for aligning micro- or nanoparticles in an elongated article, according to some implementations.

Figures 6a-c illustrate a setup for aligning micro- or nanoparticles in a planar composite material which is in the form of a sheet.

Figures 7a-c illustrate how the composite material may be provided on a substrate, arranged between two substrates or covered with at coating when the micro- or nanoparticles are to be aligned.

Figure 8 shows a cross-sectional view of a cylindrical Halbach array with three concentric subarrays, according to some implementations.

Figure 9 shows a cross sectional view of a cylindrical, two-part, Halbach array with two concentric subarrays, according to some implementations.

Figures 10a-c illustrate schematically how an antibacterial surface with exposed aligned micro- or nanoparticles can be realized.

Figure 11 illustrates schematically a laminate sheet material with varying micro- or nanoparticle alignments, which can be obtained using the alignment method according to some implementations.

#### DETAILED DESCRIPTION OF CURRENTLY PREFERRED EMBODIMENTS

**[0051]** Fig. 1a shows a cross-sectional view of a cylindrical Halbach magnet array 1. A cylindrical Halbach array 1 as such is known in the art and comprises a plurality of magnet segments 2a-h (each being realized with a permanent magnet or electromagnet) arranged concentrically around a central space 3. In the embodiment shown in fig. 1a, the segments 2ah are shaped like annular sectors giving the cylindrical Halbach array 1 a substantially cylindrical outer shape with a substantially cylindrical central space. As will be discussed below, the cylindrical Halbach array can be realized with magnet segments that are of a different shape, giving the Halbach array e.g. a polygonal outer shape and/or polygonal central space 3. Generally, however, a Halbach array may be referred to as a cylindrical Halbach array even though the outer surface is polygonal.

**[0052]** The cylindrical Halbach array 1 extends around a central axis (into the plane of fig. 1a) and has an outer diameter  $D_2$  while defining a central space 3 with a diameter  $D_1$  in a plane perpendicular to the central axis.

**[0053]** Each segment 2a-h is a permanent magnet or electromagnet wherein the direction of the magnetization of each segment 2a-h varies around the array so as to form a uniform magnetic field in the central space 3. In fig. 1a the direction of magnetization, pointing south to north, of each segment 2a-h is indicated with the arrow in each respective segment 2a-h.

**[0054]** According to implementations of the present invention, the Halbach magnet array 1 comprises eight segments 2a-h wherein e.g. each segment 2a-h is made of a magnetized material acting as a permanent magnet. Each segment 2a-h has a specific magnetization direction relative to the other segments 2a-h so as to form a homogenous, strong and linear magnetic field inside the central space 3. In the configuration shown in fig. 1a showing a cross-sectional view in a plane perpendicular to the central axis, the magnetization direction of the first segment 2a is to the right and the magnetization direction of the second segment 2b (going clockwise around the array) is downwards. Continuing around the cylindrical Halbach array 1, the magnetization direction of the subsequent segments 2c-h are left, up, right, down, left and up, respectively. In general, each segment 2a-h has a magnetization direction which is perpendicular to the magnetization direction of its neighboring segments 2a-h while any two segments 2a-h separated by a common segment have opposite magnetization directions.

**[0055]** As an example, segment 2c has a magnetization direction (left) which is perpendicular to the magnetization direction of neighboring segment 2b (down), and segments 2b and 2d which are both neighboring segments to segment 2c, and arranged on opposite sides of segment 2c, have opposite magnetization directions (down and up, respectively).

**[0056]** In other words, the magnetization direction shifts around the central axis when going from a first segment to a neighboring second segment and shifts with the same degree and in the same rotational direction around the central axis when going from the second segment to a neighboring third segment and so on. The degree of the magnetic direction shift between neighboring segments is determined as  $360 \cdot 2 / N$ , where N is the number of segments. In the embodiment shown in fig. 1a, with eight segments 2a-h, the magnetization direction shifts 90 degrees in a clockwise direction when going clockwise around the plurality of segments 2a-h. However, it is envisaged that a cylindrical Halbach array 1 with a homogenous and linear magnetic field can be realized with more or fewer segments leading to magnetization directions which will differ from the exemplary embodiment shown in fig. 1a. For example, the arrangement shown in fig. 1a provides a linear magnetic field going left to right, but it is understood that the magnetization direction of the segments 2a-h can be altered and/or

the cylindrical Halbach array rotated, to form a magnetic field pointing in a different direction in the central space 3 instead.

**[0057]** The cylindrical Halbach array 1 creates a strong, homogenous and linear magnetic field in the central space 3. In some implementations, the magnetic field strength inside the central space 3 is 0.5 T or more, such as 1 T or more. However, by e.g. using a stronger permanent magnet material in segments, using stronger electromagnets, increasing the outer diameter  $D_2$ , or decreasing the inner diameter  $D_1$  the magnetic field strength inside the central space 3 can be made even stronger.

**[0058]** In fig. 1b the magnetic field in the central space is illustrated schematically. As seen, the magnetic field is almost perfectly linear and homogenous, pointing to the right. This property, having a highly homogenous and linear magnetic field, makes the cylindrical Halbach array 1 suitable for alignment of micro- or nanoparticles. Additionally, the inner diameter  $D_1$  can be made arbitrarily large which can provide a large central space 3 with linear magnetic fields. By comparison, if a single magnet or a magnet pair were used instead, the magnetic field will diverge, and it is only in a very small region that the magnetic field is linear.

**[0059]** By varying the shape of each segment 2a-h, different types of cylindrical Halbach arrays 1 can be provided. For example, as shown in fig. 1a and 1b the cross-section of the segments are shaped like annulus sectors providing a substantially cylindrical outer surface and a substantially cylindrical central space 3. However, other cross-sectional shapes of the segments 2a-h are also envisaged as will be described with further reference to fig. 2a-d.

**[0060]** In fig. 2a, a segment 2 with a trapezoidal cross-section is shown. In some implementations, the cylindrical Halbach array 1 is formed by arranging a plurality of such trapezoidal segments in the same cylindrical pattern as shown in fig. 1a. The trapezoidal segments 2 may be isosceles trapezoidal segments having pairwise equal angles at the vertices. With this type of segments a very strong magnetic field can be realized.

**[0061]** In fig. 2b, a segment 2 with a cross-section forming an annulus sector is shown. The annulus sector segments are used in the cylindrical Halbach array 1 shown in fig. 1a and fig. 1b, forming a substantially cylindrical concentric Halbach array 1. With this type of segment, the magnetic field inside the central space will be highly linear.

**[0062]** In fig. 2c, a segment 2 with a trapezoidal cross-section modified with two concave surfaces 21, 22 is shown. When this type of segment 2 is used in the cylindrical Halbach array the major concave surface 21 faces outwards while the minor concave surface 22 faces the central space 3.

**[0063]** In fig. 2d, a segment 2 having a trapezoidal cross-section modified with a minor concave surface 22 is shown. When this type of segment 2 is used in

cylindrical Halbach array 1 the minor concave surface 22 faces the central space 3 forming a Halbach array with a cylindrical central space 3 but polygonal outer surface.

**[0064]** The segment shapes shown in figs. 2a-d are merely exemplary and in general it is understood that any shape may be used as long as the segments are arranged with the correct magnetization direction, e.g. as illustrated in fig. 1a and fig. 1b. For example, each segment 2 may have a cross-section which is substantially square or rectangular. It is also envisaged that each segment may be circular or even triangular in cross-section.

**[0065]** Additionally, while it may be preferable for each of the plurality of segments 2a-h to have the same cross-sectional shape (to obtain the most homogenous magnetic field in the central space 3) it is also envisaged that different shapes can be combined. For example, the trapezoidal segment shape shown in fig. 2a may be used for one or more segments and the annulus section shape shown in fig. 2b may be used for some other segments.

**[0066]** A difference with using different segment shapes is that the resulting magnetic field strength and/or linearity inside the central space 3 varies depending on the shape. It has been found that using segments with a trapezoidal cross-section as shown in fig. 2a provides the greatest magnetic field strength inside the central space 3 out of the segment shapes shown in figs. 2a-d. Another benefit with the segments having a trapezoidal cross-section is that these segments may be easier to manufacture (compared to e.g. annulus section segments) since this shape does not feature any curved surfaces. While the segments with trapezoidal cross-section from fig. 2a feature excellent linearity as well it has further been found that the best linearity is obtained using the segments with annulus sector cross-section as shown in fig. 2b.

**[0067]** Another factor which has been found to impact the resulting magnetic field strength is whether the segments 2a-h are in direct contact with each other or separated by a dielectric material or air gap. The segments 2a-h are preferably arranged so as to contact each other, as this has been found to increase the resulting magnetic field strength. For example, for segments with a trapezoidal cross-section the field strength increases by more than 15 % when the segments are in contact with each other compared to when they are separated by an air gap.

**[0068]** Fig. 3 is a flowchart illustrating a method for aligning micro- or nanoparticles in a matrix material and with further reference to fig. 4a-d this method will now be described.

**[0069]** At step S1 a composite material 5 is provided. As shown in fig. 4a the composite material comprises a matrix 9 and micro- or nanoparticles 8 added to the matrix 9. Prior to alignment, the micro- or nanoparticles 8 are arranged randomly inside the matrix 9.

**[0070]** Many types of matrices 9 can be used. The matrix may be a solid or a liquid. For example, the matrix

9 is a dispersion, a hydrogel, a crosslinkable resin (e.g. a curable resin such as a light/UV or heat curable resin), or a thermosetting polymer such as, but not limited to, acrylate resins, epoxy resin, polyurethanes, vulcanized rubber, or silicone resins. The matrix 9 may also be a plastic material such as a polymer matrix. The polymer matrix may be a thermoplastic polymer. Examples of thermoplastic polymers include polycarbonates (PC), polyesters, polyethers, polyamides, polyurethanes, polyethylene (PE), polypropylene (PP), polyvinyl chloride (PVC), polyvinyl esters, polyvinyl amides, polyacrylates, polymethacrylates, copolymers comprising ethylene, such as polyethylene co-acetate, and polyolefin based elastomers, such as combinations of polypropylene (PP), styrene-ethylenebutylene-styrene (SEBS) and polyethylene (PE). Preferably the thermoplastic polymer is realized as low density polyethylene (LDPE), low-density polybutylene (LDBE), and/or polypropylene (PP).

**[0071]** As the micro- or nanoparticles 8 will be re-oriented while inside the matrix 9, a resin matrix, a liquid matrix, or a gel matrix may be preferred since this will require less time and/or a weaker magnetic field to achieve alignment of the micro- or nanoparticles 8. However, since the cylindrical Halbach array 1 of the present invention can be made arbitrarily large to generate strong magnetic fields it is envisaged that the matrix may even be a solid material, while still allowing the micro- or nanoparticles 8 to align with the magnetic field.

**[0072]** For example, the micro- or nanoparticles are in fact nanoparticles such as 0D, 1D, 2D or 3D nanoparticles.

**[0073]** Examples include cellulose nanocrystals (1D nanoparticle), graphene flakes (2D nanoparticle), wood fibers (3D nanoparticle), MXenes (2D nanoparticle) and boron nitride (2D nanoparticle). The nanoparticles 8 may also be doped with various doping materials. For example, the graphene flakes may be doped with boron, nitrogen or the like, or modified in other, per se known, ways. Other 2D nanoparticles 8 may also be used, such as graphyne, germanene, silicone, phosphorene, etc. All the nanoparticles 8 are preferably of one material. However, combinations where the nanoparticles 8 are of two or more materials are also feasible.

**[0074]** For zero-dimensional (0D) nanoparticles, all dimensions are confined to the nanoscale, typically not exceeding 500 nm or 100 nm. This category, e.g. includes quantum dots and nanoparticles where electrons are confined in all three spatial dimensions, leading to unique optical and electronic properties. For example, some 0D nanoparticles, i.e. those that have no anisotropy, which therefore cannot be individually aligned with a magnetic field will form chains or large scale structures when subject to a magnetic field. Hereby, "aligning" may not only refer to alignment of each individual particle but could also include alignment of multiple particles such that they form large scale structures (often referred to as chains). For one-dimensional (1D) nanoparticles, one dimension extends beyond the nanoscale, allowing elec-

tron movement along their length. Examples include nanotubes, nanorods, and nanowires. For two-dimensional (2D) nanoparticles, two dimensions extend beyond the nanoscale. Examples include graphene, nanofilms, and nanocoatings. For three-dimensional (3D) nanoparticles none of the dimensions are confined to the nanoscale. Examples of 3D nanoparticles are bulk powders, dispersions of nanoparticles, aggregates of nanowires and nanotubes, and layered structures. While e.g. wood fibers typically are seen as 1D materials due to their elongated structure, a wood fiber is very large in the nanoscale resulting in wood fibers typically being classified as a 3D nanoparticle while still being a 1D micro-

**[0075]** In some implementations, and in particular when the nanoparticles are to be used to form an antibacterial surface, the nanoparticles 8 may be nanoscale flakes or platelets (such as graphene flakes), i.e. an even or uneven piece of material with one dimension, the thickness, substantially smaller than the other two dimensions (length and height). The thickness is of nanoscale or nano dimension, i.e. between 0.01 and 100 nm, and preferably between 0.1 and 50 nm. In some implementations, the flakes or platelets have an average thickness in the range of 0.01-20 nm, and preferably in the range 0.1-15 nm, and more preferably in the range of 0.5-10 nm, and most preferably in the range of 1-5 nm. The nanoscale flakes or platelets preferably have an average width in the range of 1-30 microns, and preferably in the range of 1-20 microns, and more preferably in the range of 2-15 microns, and most preferably in the range of 3-15 microns.

**[0076]** However, since the Halbach array forms such a strong magnetic field not only nano particles but even microparticles can be aligned using the Halbach array. In general, it is envisaged that even larger particles can be aligned. For example, any oblate or prolate particle can be aligned with the Halbach array. Optionally, a magnetic particle is attached to the oblate or prolate particle to make it interact more strongly with the magnetic field.

**[0077]** All materials (including micro- or nanoparticles) are diamagnetic wherein they can be aligned with a magnetic field. However, some micro- or nanoparticles 8 will require an excessively strong magnetic field to align. For example, graphene flakes are diamagnetic and require an ultra-high magnetic field of more than 10 T to align. Since generating such a strong magnetic field may be impractical for large-scale production of graphene-aligned composite materials, it is envisaged the micro- or nanoparticles are first doped with magnetic particles prior to being added to the matrix, wherein the micro- or nanoparticles will interact more strongly with the magnetic field making them easier to align.

**[0078]** In one exemplary embodiment, the micro- or nanoparticles are doped with iron oxide  $\text{Fe}_3\text{O}_4$  which attaches to the micro- or nanoparticles using strong electrostatic adsorption and/or van der Waals attraction. For example, it has been found in a pH 7.0 suspension of

iron oxide  $\text{Fe}_3\text{O}_4$  and graphene oxide (GO) generates  $\text{GO}@Fe_3O_4$  wherein the  $\text{Fe}_3\text{O}_4$  particles attach to the graphene flakes using electrostatic adsorption and van der Waals attraction. To further enhance the electrical, thermal and mechanical properties of graphene after attachment of the  $\text{Fe}_3\text{O}_4$  particles, chemical reduction is conducted leading to the generation of reduced graphene oxide still bound to the iron oxide particles  $rGO@Fe_3O_4$ . For example, the reduction is performed at 90 degrees Celsius in hydrazine.

**[0079]** Other magnetic particles besides iron oxide  $\text{Fe}_3\text{O}_4$  can also be used, such as neodymium magnet particles or samarium-cobalt magnet particles.

**[0080]** Of course, there exists micro- or nanoparticles which are magnetic, meaning that it may not always be necessary to attach magnetic particles. For example, there are sheets and rods of ferro or paramagnetic micro- or nanoparticles which can also be oriented in a matrix material and used for different applications without requiring the extra step of attaching magnetic particles to diamagnetic micro- or nanoparticles.

**[0081]** At step S2, a cylindrical Halbach array with a plurality of magnet segments is provided (see e.g. fig. 1a). The cylindrical Halbach array defines a central space 3 and at step S3 the composite material 5 is arranged inside the central space 3 whereby the composite material 5 is exposed to the strong, homogenous, and linear magnetic field generated at the center of the Halbach array.

**[0082]** The magnetic field will align the micro- or nanoparticles 8 and, as seen in fig. 4c, the micro- or nanoparticles 8 have been aligned along the x-axis. Comparing fig. 4a with fig. 4c clearly reveals that the 2D micro- or nanoparticles 8 of this example have gone from being arranged randomly to being aligned along the x-axis. To achieve this alignment the magnetic field of the cylindrical Halbach array is parallel to the x-axis.

**[0083]** Fig. 4b and 4d show a cross-sectional view in the yz-plane, looking along the x-axis, and here it is also seen that the magnetic field aligns all the 2D micro- or nanoparticles such that their respective surface normal lies in the yz-plane. The rotation of the 2D micro- or nanoparticles around the x-axis may, however, not be aligned with each other if a stationary magnetic field is used and/or if the magnetic exposure time is too short. To form alignment also in the yz-plane a rotating magnetic field can be used as will be described below.

**[0084]** If 1D micro- or nanoparticles are used instead, a stationary magnetic field may be sufficient to align the micro- or nanoparticles completely.

**[0085]** At step S4, the composite material is removed from the cylindrical Halbach array, wherein the composite material comprises aligned micro- or nanoparticles 8 suspended in the matrix 9. Optionally, prior to or after removing the composite material 5, the matrix is cured (using light if it is a light-curable resin or heat if it is a heat curable resin) so as to lock the aligned orientation of the micro- or nanoparticles 8. In some implementations, the

matrix 9 is a heated and molted thermoplastic material when it is arranged in the cylindrical Halbach array wherein the matrix 9 is cooled (passively or actively) after, during or prior to removal of the composite material 5 from the cylindrical Halbach array so as to lock the aligned orientation of the micro- or nanoparticles 8.

**[0086]** Turning to figs. 4e-f and fig. 5a-b, it is illustrated that alignment of the micro- or nanoparticles 8 may also be achieved using a magnetic field which rotates relative to the composite material 5.

**[0087]** As illustrated in fig. 5a, the cylindrical Halbach array 1 can be made to rotate around its central axis C. Thereby, the linear magnetic field inside the central space 3 rotate relative the composite material 5 such that the micro- or nanoparticles 8 inside the matrix are arranged in a rotating magnetic field. For 2D micro- or nanoparticles (such as graphene flakes) the rotating magnetic field will cause the micro- or nanoparticles 8 to align with their surface normal parallel to the rotational axis C. That is, the resulting alignment of micro- or nanoparticles for a section of the composite material will be as shown in fig. 4e and 4f if the axis around which the magnetic field rotates is parallel to the z-axis (i.e. at any point in time during the rotation the magnetic field direction lies in the xy-plane).

**[0088]** Of course, the same type of alignment may be achieved if the cylindrical Halbach array 1 is stationary and the composite material 5 rotates instead, or if both the cylindrical Halbach array 1 and the composite material 5 rotates. However, in many practical implementations it is easier to rotate the cylindrical Halbach array 1 around the composite material 5 than vice versa.

**[0089]** In some implementations, the rate at which the magnetic field rotates (i.e. the rate at which one of the composite material 5 and cylindrical Halbach array rotates relative to the other one) is at least 10 RPM, at least 100 RPM or at least 600 RPM.

**[0090]** In fig. 5a, the composite material sample 5 is inserted and subsequently removed from the Halbach array using a sample holder 41 which grips the composite material 5. The manufacturing system of fig. 5a further comprises an actuator 42 which moves the sample holder 41 into (and subsequently removes it from) the Halbach array 1. It is understood that a separate linear actuator 42 coupled to a sample gripper 41 is merely exemplary and the actuator 42 and sample holder 41 may be formed by the same component. For example, the composite material is fed into and out of, the Halbach array 1 by being squeezed between two rollers. Also, removing the composite material from the central space 3 does not necessarily mean that the composite material is pulled out from the same opening in the Halbach array 1 through which it was inserted. As the central space 3 forms a hollow channel extending through the Halbach array 1, it is envisaged that the sample holder 41 and actuator 42 are configured to move the sample all the way through the channel, to the other side.

**[0091]** While fig. 5a shows the that the Halbach array

1a rotates, it is understood that the same setup may be used to align micro- or nanoparticles with a stationary magnetic field, if the Halbach array is kept stationary.

**[0092]** Fig. 5b shows another example of how the cylindrical Halbach array 1 can be used to align the micro- or nanoparticles in an inline production process. In this example, the composite material 5 is extruded from an extruder 43 wherein the composite material 5, downstream of the extruder 43, is passed through the central space 3 of a cylindrical Halbach array 1. That is, the extruder 43 acts as both the sample holder 41 and the actuator 42 from fig. 5a.

**[0093]** The cylindrical Halbach array 1 rotates around the central axis C, whereby the composite material is subject to a rotating magnetic field which aligns the micro- or nanoparticles 8. It is also envisaged that the cylindrical Halbach array 1 is kept stationary, whereby the micro- or nanoparticles 8 are aligned by a stationary magnetic field, resulting e.g. in the alignment shown in fig. 4c and 4d. Additionally or alternatively, it is envisaged that the Halbach array 1 is mounted onto the extruder 43 (or the actuator 42 in fig. 5a) or that the Halbach array 1 is separate from the extruder 43 (or the actuator 42 in fig. 5a).

**[0094]** The length L of the cylindrical Halbach array 1 along the central axis can vary and may be configured based on the desired alignment result. It is understood that depending on the speed at which the composite material 5 is fed through the cylindrical Halbach array 1, and the length L of the cylindrical Halbach array 1, the total time during which the composite material 5 is exposed to the magnetic field will vary. In general, the exposure time may be tuned based on the rheology of the composite material. While longer exposure times could mean that a larger portion of the micro- or nanoparticles become fully aligned a too long exposure time risks causing the nano particles to migrate to the surface and/or be pulled out from the matrix material.

**[0095]** The inline process shown in fig. 5b may be used to form elongated articles (such as catheters, tubes or threads) and it is understood that the shape of the composite material piece that is passed through the central space can be any desirable shape. For example, the composite material piece may have a cross-sectional shape which is square, oval, elliptical, triangular or polygonal. The composite material piece may also be hollow or solid.

**[0096]** In another exemplary manufacturing process, the cylindrical Halbach array 1 is split into two parts 1a, 1b along a radial direction (perpendicular to the central axis C), as shown in fig. 6a. Since the cylindrical Halbach array 1 comprises a plurality of segments 2 the cylindrical Halbach array 1 can be split into two parts 1a, 1b by merely using at least one segment 2 as the first part 1a and the at least one remaining segment 2 used as the second part 1b. In some implementations, the Halbach array comprises at least four, or at least eight segments, wherein each part comprises at least two or at least four

segments. The two parts 1a, 1b can be held together so as to form a gap 3' between the two parts 1a, 1b. The gap 3' extends from the central space and enables the two Halbach array parts 1a, 1b to be moved over a planar composite material, such as a composite material sheet or a composite material coating arranged on a planar substrate as shown schematically in fig. 6b.

**[0097]** While the linear magnetic field in the central space is somewhat disrupted by separating the two half parts 1a, 1b of the Halbach array 1 to form the gap 3' the magnetic field in the central space is still approximately linear while still exhibiting a strong magnetic field strength. A benefit with splitting the Halbach array 1 into two half-portions is that planar composite material in the form of a sheet can be fed through the gap 3' of the Halbach array, perpendicular to the central axis C, to align the micro- or nanoparticles of the composite material.

**[0098]** Since the axial length L of the Halbach array 1 can be arbitrarily long, it is envisaged that the split Halbach array 1 can be used in e.g. an inline a roll-to-roll manufacturing process wherein the composite material 5 is provided as sheet which is fed through the gap 3' of the Halbach array 1 to align the micro- or nanoparticles. Optionally, after passing through the gap 3' of the Halbach array 1 the composite material is cooled, cured or hardened to lock the position of the aligned micro- or nanoparticles.

**[0099]** In some implementations, each Halbach array half-portion 1a, 1b is rotated about a rotational axis R which is parallel to a surface normal of the planar composite material (such as a sheet composite material or a coating composite material 5 that is passed through the gap 3'. Accordingly, a rotating magnetic field may be generated to align the micro- or nanoparticles also when the Halbach array is split into two portions 1a, 1b and used to process a large planar composite material such as sheet or coating composite material 5.

**[0100]** Turning to fig. 6c, an example of a two-part Halbach array 1 with segments 2a', 2a", 2b-d, 2e', 2e", 2f-h having a trapezoidal cross-section is shown. Although it is envisaged that the two-part Halbach array 1 is realized by simply separating four neighboring segments from four other neighboring segments to form the two portions 1a, 1b fig. 6c shows that it is also possible to perform the split through two opposite segments. In this case, segments 2a' and 2a" belong to different half portions 1a, 1b but would have constituted a single trapezoid segment if the two half-portions were to be combined to form a single cylindrical Halbach array. The same also applies to segments 2e' and 2e" which together form a single trapezoid segment, but which have now been separated into two different half parts. In general, depending on the desired orientation direction of the composite material, the Halbach array 1 is split into two portions 1a, 1b along a radial direction, and if the radial direction intersects two opposite segments, the two intersected segments can be split into two parts, each having

the same magnetization direction and each being used in a different half section. Accordingly, in some embodiments, a two-part Halbach array 1 comprises five segments in each half portion 1a, 1b, three complete segments 2b-2d, 2f-2h and two partial segments 2a', 2a", 2e', 2e".

**[0101]** Optionally, the two-part Halbach array 1 is arranged in a housing 7 wherein the housing is moved over a stationary (or moving) planar composite material 5. Since the planar composite material 5 separates the two half-portions 1a, 1b the housing may also be split into two parts, with one part above, and one part below, the planar composite material. By moving the two parts of the Halbach array 1 in tandem over the planar composite material using an actuator (e.g. using robotic arms) it is possible to align the micro- or nanoparticles of very large planar composite materials, such as a sheet composite material or a composite material applied as a coating to a planar substrate. In fig. 6c the two-part Halbach array 1 is moved to the right across a stationary planar composite material 5. That is, even with the two-part Halbach array 1 a manufacturing system with an actuator which moves the Halbach array (or the planar composite material) is provided. The planar composite material is further held by a sample holder which e.g. is realized as a conveyor, a gripping claw or two rolls, wherein the planar composite material is rolled of one roll and onto another roll or wherein the planar composite material is moved by being squeezed between the two rollers.

**[0102]** In some implementations, the two-part Halbach array 1 is moved together with one or more upstream heating elements 6a. For example, as shown in fig. 6c the upstream heating element(s) 6a are attached to the housing 7. The upstream heating element(s) 6a are configured to heat the planar composite material before, or at the same time as, it enters into the gap 3' of the Halbach array 1. The heating may e.g. be achieved using electric heating elements, using a laser, or using a heating light. The heating may e.g. decrease the viscosity of the matrix in the composite material 5, which makes it easier and/or faster to align the micro- or nanoparticles once they enter the Halbach array 1 and are exposed to the magnetic field. Optionally, two upstream heating elements are provided, each configured to heat a respective surface of the planar composite material.

**[0103]** Additionally or alternatively, the two-part Halbach array 1 is moved together with one or more downstream cooling/curing elements 6b. For example, as shown in fig. 6c, the downstream cooling/curing element(s) 6b are attached to the housing 7. As described above, the composite material 5 may comprise a matrix which is curable by heat or light (e.g. UV light). For example, the matrix is a polymer which forms crosslinks when exposed to heat and/or certain wavelengths of light. Hereby, the downstream cooling/curing element(s) 6b may e.g. heat the composite material 5, or irradiate the composite material 5 with a specific curing light, as it leaves the Halbach array 1, wherein the material cures

and locks the aligned micro- or nanoparticles into their aligned positions. In some implementations, the cooling/curing element(s) 6b are configured to cool the composite material coming out from the Halbach array 1. In some implementations, the composite material is heated prior to being inserted into the Halbach array 1 so as to make the matrix less viscous and/or so as to partially or fully melt the matrix. For example, the matrix is a thermoplastic material. By cooling the composite material as it comes out of the Halbach array 1 the matrix solidifies and/or gets higher viscosity which locks the aligned micro- or nanoparticles in place.

**[0104]** It is envisaged that in some implementations, only one of the half-portions 1a, 1b shown in fig. 6a-c is used to align the micro- or nanoparticles. While it is preferable to use both half-portions 1a, 1b since this generates the most uniform and linear magnetic field, a single half-portion 1a, 1b still has the benefit of generating a strong magnetic field which can be used for alignment when magnetic field uniformity is less important.

**[0105]** Turning to fig. 7a, an example of a composite material 5 applied as a coating to a substrate material 55 is shown. The composite material 5 may be deposited onto the substrate 55 using a variety of techniques. For example, the composite material 5 is a dispersion which is sprayed, poured or otherwise applied to the substrate 55. The magnetic field generated by the Halbach array will penetrate the substrate 55 and align the micro- or nanoparticles of the composite material 5. After or during alignment, the composite material 5 is optionally cured to lock the alignment of the micro- or nanoparticles. For example, if the composite material is a dispersion comprising solid micro- or nanoparticles dispersed in a liquid, the curing is performed after or during the alignment by e.g. actively evaporating the liquid to leave the aligned micro- or nanoparticles on the substrate 55. In fig. 7a the substrate 55 with the composite material 5 coating forms a layered laminate with the composite material 5 exposed which e.g. can be aligned using the two-part Halbach array shown in figs. 6a-c. However, it is not necessary that the composite material 5 coating is exposed, for example the composite material 5 may be located between two substrate layers 55a, 55b as shown in fig. 7b. The magnetic field generated by the Halbach array will penetrate through the substrate layers 55a, 55b allowing the micro- or nanoparticles of the composite material 5 to align.

**[0106]** Fig. 7c shows a cross-section of an example of a composite material 5 which is covered with an exterior coating 56. While fig. 7c shows the circular cross-section of a cylindrical composite material 5 this is merely exemplary and an oval, elliptical or polygonal cross-section may also be used in other implementations. The coating 56 partially or fully surrounds the composite material 5 but still allows the magnetic field generated by the Halbach array (e.g. the Halbach array shown in figs. 5a-b and figs. 6a-c) to reach the composite material 5 and act to align

the micro- or nanoparticles therein. Accordingly, another benefit with magnetic alignment of micro- or nanoparticles using strong magnetic fields generated by a Halbach array is that it is not necessary for the composite material 5 to be exposed, it may e.g. be substantially or completely covered by one or more substrate layers 55, 55a, 55b or a coating 56 during the alignment.

**[0107]** The coating 56 or substrate layer(s) 55, 55a, 55b may be devoid of micro- or nanoparticles and/or not interact with the magnetic field in any way. For example, the coating 56 or substrate layer(s) 55, 55a, 55b may serve to protect the composite material during manufacturing to be subsequently removed. For instance, the coating 56 or substrate layer(s) 55, 55a, 55b is made of a dissolvable material which is dissolved after alignment (and optionally curing) of the composite material.

**[0108]** Alternatively, the coating 56 or substrate layer(s) 55, 55a, 55b may comprise micro- or nanoparticles which are also aligned by the Halbach array or which have already been aligned and locked into the aligned state by curing. The micro- or nanoparticles in the composite material 5 may be the same, or different, micro- or nanoparticles than the particles provided in the coating 56 or substrate layer(s) 55, 55a, 55b. In this way, various complex structures of laminated layers with different micro- or nanoparticles and/or different alignment can be created and used in a wide variety of implementations.

**[0109]** In the above, various embodiments of the Halbach array have been presented and it is understood that e.g. the cross-sectional shape of each segment can be varied and that the number of segments can also vary. Additionally, the Halbach array can be used in an alignment process wherein the composite material is inserted along the channel formed by the central space (see fig. 5a and 5b) or the Halbach array is split into two half-portions allowing e.g. a sheet shaped composite material (or a composite material deposited onto a substrate) to pass through the gap formed between the two half-portions (see fig. 6a-c).

**[0110]** Since the size and dimensions of the central space inside the Halbach can be varied it is understood that micro- or nanoparticles of a planar composite material (such as a composite material in the form of a coating applied to/between a substrate(s)) can be aligned with a single-part Halbach array (as shown in fig. 5a and 5b) by feeding the composite material through the central space along the central axis. Also, an elongated (e.g. cylindrical composite material (optionally provided with a coating) can be processed by a two-part Halbach array by moving the composite material through the gap between the two half-portions.

**[0111]** In fig. 8 and fig. 9, other envisaged embodiments of the Halbach array 1 are shown. In fig. 8, a cross-sectional view of a Halbach array 1 with multiple cylindrical (and concentrically arranged) subarrays is shown. An innermost subarray comprises eight segments 2 surrounding the central space 3. An intermediate

subarray, surrounding the inner subarray, comprises sixteen segments 2. An outermost subarray, surrounding the intermediate subarray, comprises twenty-two segments 2. By arranging multiple cylindrical subarrays of segments 2 around the central space 3 (each subarray being axisymmetric and concentric around the central space 3) an even stronger, and even more uniform, magnetic field can be generated which facilitates alignment of the micro- or nanoparticles in the composite material passed through the central space 3.

**[0112]** While fig. 8 shows three subarrays, it is envisaged (?) that two subarrays, or more than three subarrays, may also be used. Each subarray comprises at least as many segments as the subarray which it surrounds and preferably each subarray comprises more segments than the subarray which it surrounds. For example, for each pair of adjacent subarrays the inner cylindrical Halbach subarray has N segments and the outer cylindrical Halbach subarray has M segments, wherein  $M > N$ . Preferably, the innermost subarray comprises at least two segments 2. If only a single subarray is used, the single subarray preferably comprises at least four or at least six segments.

**[0113]** In fig. 8, each segment has a substantially square cross-section, but it is envisaged that other shapes (such as those shown in fig. 2a-d) can be used. Also, it is understood that Halbach arrays with multiple cylindrical subarrays can be divided into two parts and used for flat composite materials such as sheet shaped composite materials or composite materials deposited onto a substrate as described in connection to fig. 6a-c. An example of a two-part Halbach array with two subarrays is shown in fig. 9.

**[0114]** As seen in fig. 9, the Halbach array comprises an outer subarray with ten segments 2a', 2a'', 2b-d, 2e', 2e'', 2f-h and an inner subarray with two segments 2i, 2j. The segments of the outer subarray 2a', 2a'', 2b-d, 2e', 2e'', 2f-h have a cross-section of an annulus sector and the two segments of the inner subarray have a cross-section forming a half circle with magnetization directions indicated by the arrows inside each segment. Since the segments 2a', 2a'', 2b-d, 2e', 2e'', 2f-h of the outer subarray forms a concave central space having some void space which would not be occupied by the composite material as it passes through the gap 3' between the two half-portions 1a, 1b (see e.g. fig. 6c) the void space is preferably provided with the two additional segments 2i, 2j forming an inner subarray which amplifies the magnetic field within the gap 3'. Consequently, the high magnetic field strength enables the precise orientation of micro- or nanoparticles in the matrix material, e.g. when high viscosity matrix material is used.

**[0115]** If the cross-sectional shape of the segments 2a', 2a'', 2b-d, 2e', 2e'', 2f-h in the outer subarray is different than shown in fig. 9 (e.g. trapezoidal instead of annulus sectors) the shape of the segments 2i, 2j in the inner subarray will be adapted accordingly, preferably in such a way that the segments 2i, 2j occupies the entire

central space portion of each half-portion 1a, 1b without obstructing the gap 3'.

**[0116]** The above described method for aligning micro- or nanoparticles in a composite material can be used for a wide variety of applications.

**[0117]** For example, an antibacterial surface can be formed by removing (e.g. by chemical etching, laser etching or cutting) a portion 5b of an aligned composite material as shown in fig. 10a. For example, the matrix 9 is dissolved at a portion 5b of the composite material leaving a surface wherein the aligned micro- or nanoparticles are exposed. Fig. 10b and 10c show exemplary side views of the remaining portion 5a, showing micro- or nanoparticles extending from the surface of the matrix 9. This surface has been shown to be antibacterial by either prohibiting bacteria from attaching to the surface or killing bacteria. In some implementations, the composite material 5 is provided on a substrate (as a coating) or itself covered with a coating whereby to form the antibacterial surface the substrate or coating is removed (e.g. by chemical etching) leaving the composite material 5. For example, the portion 5b which is removed may be a substrate or coating wherein the portion 5a is the composite material.

**[0118]** Additionally, it has been found that the alignment of micro- or nanoparticles will influence the optical properties of the material. For example, graphene aligned in an epoxy resin will influence the optical transmission through the epoxy. Experiments have shown that randomly oriented graphene flakes in the epoxy resin yield a light transmission of about 27%. However, when the graphene flakes are aligned in a rotating or static magnetic field generated by the Halbach array, the light transmission was 43% and 37% for the rotating and static field respectively, when viewed perpendicular to the surface normal to the aligned graphene flakes. Additionally, the light transmission in a direction parallel to the surface normal of the graphene flakes was 11% and 19% respectively for the graphene flakes aligned with a rotating and static magnetic field, respectively.

**[0119]** Similarly, the electrically conductive or thermal conductive properties of the material can be changed. Notably, by using the two-part Halbach array 1 a planar composite material (e.g. a sheet) with micro- or nanoparticles aligned parallel to, or perpendicular to, the normal of the plane can be created, wherein the planar material will feature a natural bias for leading electrical currents, or heat, through or along the planar material. Of course, other alignments are also possible and in general the micro- or nanoparticles can be aligned at any angle with respect to the planar surface normal.

**[0120]** In fig. 11, a laminate arrangement of composite material sheets 51, 52, 53, with micro- or nanoparticles 8 arranged in different directions, is shown. In the top sheet 51, the micro- or nanoparticles are aligned parallel to the normal of the sheet 51, in the middle sheet 52, the micro- or nanoparticles are aligned so as to form an angle of about 45 degrees relative the normal direction of the

sheet 52, and in the bottom sheet 53, the micro- or nanoparticles 8 are aligned so as to be substantially perpendicular to the normal direction of the sheet 53. With this arrangement, electric currents and/or heat incident against the outer surface of the top sheet 51 may be generally guided along lines 55. Accordingly, this laminate arrangement of sheets may be used as a thermal or electrical insulator. Each sheet 51, 52, 53 may be produced using the two-part Halbach array shown in figs. 6a-6c.

**[0121]** Additionally, it is noted that while the cylindrical Halbach array shown in fig. 1a-b and fig. 6c comprises eight segments (ten counting the segments which has been split in to in fig. 6c), it is understood that the Halbach array may comprise fewer or more segments such as six segments, ten segments, twelve segments, sixteen segments or more. Using fewer than six segments risk making the structure too simplistic wherein the homogenous and linear properties of the central space will be deteriorated. To this end, six or more segments (such as eight or more) are preferred.

### Claims

1. A method for aligning micro- or nanoparticles in a matrix material, the method comprising:

providing a sample of a composite material, the composite material comprising matrix material with micro- or nanoparticles;  
 providing a cylindrical Halbach array of magnets, the cylindrical Halbach array comprising a plurality of magnets arranged symmetrically around a central space;  
 arranging the composite material sample inside the central space of the cylindrical Halbach array to align the micro- or nanoparticles; and  
 removing the composite material sample from the central space.

2. The method according to claim 1, wherein the micro- or nanoparticles are paramagnetic, ferromagnetic or ferrimagnetic.
3. The method according to any of the preceding claims, wherein the micro- or nanoparticles comprise at least one of cellulose nanocrystals, graphene, wood fibers, MXenes and boron nitride.
4. The method according to claim 1 or claim 3, wherein providing a sample of a composite material comprises:

providing a matrix material;  
 providing micro- or nanoparticles;  
 attaching magnetic particles to the micro- or nanoparticles to make the micro- or nanoparti-

cles magnetic; and  
 adding the magnetic micro- or nanoparticles to the matrix material.

5. The method according to claim 4, wherein the magnetic particles are paramagnetic, ferromagnetic or ferrimagnetic particles.
6. The method according to any of claims 4-5, wherein the magnetic particles are iron oxide particles and the micro- or nanoparticles are nanoparticles, such as 2D graphene flakes.
7. The method according to any of the preceding claims, wherein the magnets of the Halbach array are permanent magnets.
8. The method according to any of claims 1-6, wherein the magnets of the Halbach array are electromagnets.
9. The method according to any of the preceding claims, wherein the cylindrical Halbach array comprises magnets with a trapezoidal cross-section or magnets with a cross-section of an annulus sector.
10. The method according to any of the preceding claims, wherein the magnets of the cylindrical Halbach array are arranged in direct contact with each other.
11. The method according to any of the preceding claims, wherein the Halbach array comprises an inner cylindrical Halbach subarray with N segments and an outer cylindrical Halbach subarray with M segments, wherein  $M > N$ .
12. The method according to any of the preceding claims, wherein the cylindrical Halbach array extends along a central axis, wherein the method further comprises:  
 rotating, around the central axis, at least one of the cylindrical Halbach array and the composite sample relative the other one of the Halbach array and the composite sample, so as to align the micro- or nanoparticles with a magnetic field which rotates relative the composite sample.
13. The method according to any of the preceding claims, further comprising:  
 linearly displacing the composite sample relative the cylindrical Halbach array along the central axis.
14. The method according to any of claims 1 - 11, wherein the cylindrical Halbach array is split into two half portions along a radial direction such that each half portion comprises at least one magnet and wherein the composite sample is a planar material, the meth-

od further comprising:

displacing the planar composite material relative the two half portions of the cylindrical Halbach array such that the planar composite material moves through a gap between the two half-portions and through the central space. 5

15. The method according to any of the preceding claims, further comprising:

heating the composite material prior to it being arranged in the central space of the cylindrical Halbach array, and/or cooling, curing or crosslinking the composite material after it has been removed from the central space. 10  
15

16. The method according to any of the preceding claims, wherein the nano or microparticles are nanoparticles, such as 0D nanoparticles, 1D nanoparticles, 2D nanoparticles or 3D nanoparticles. 20

17. The method according to any of the preceding claims wherein the micro- or nanoparticles are anisotropic. 25

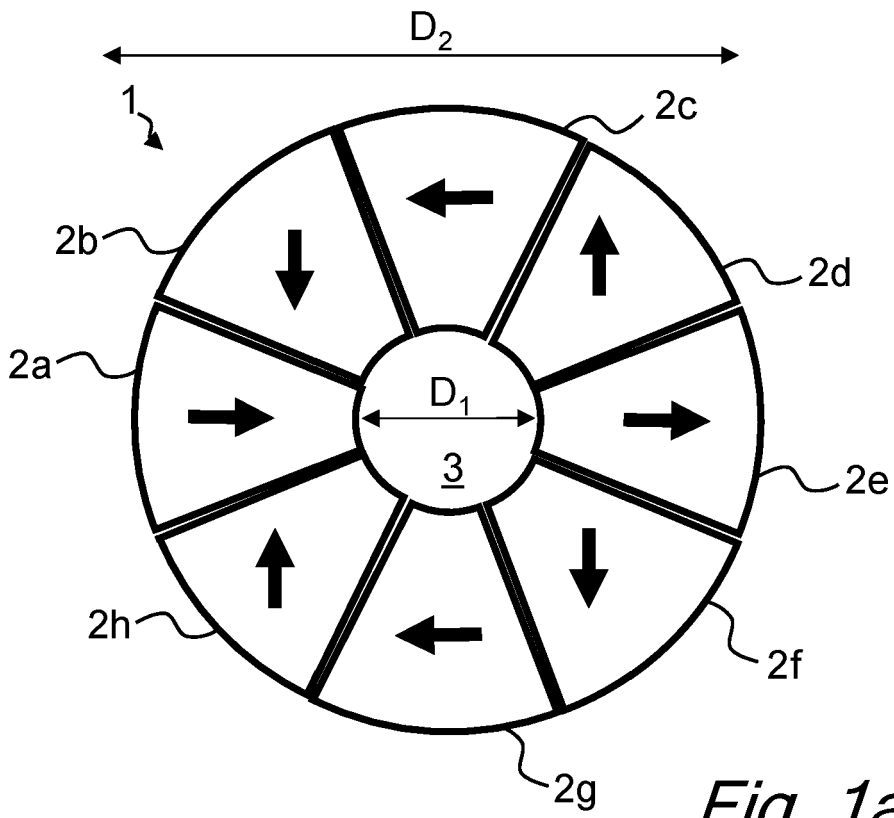
18. The method according to any of the preceding claims, wherein the cylindrical Halbach array of magnets comprises eight magnets arranged concentrically around the central space. 30

19. An apparatus for aligning micro- or nanoparticles in a matrix material, the apparatus comprising:

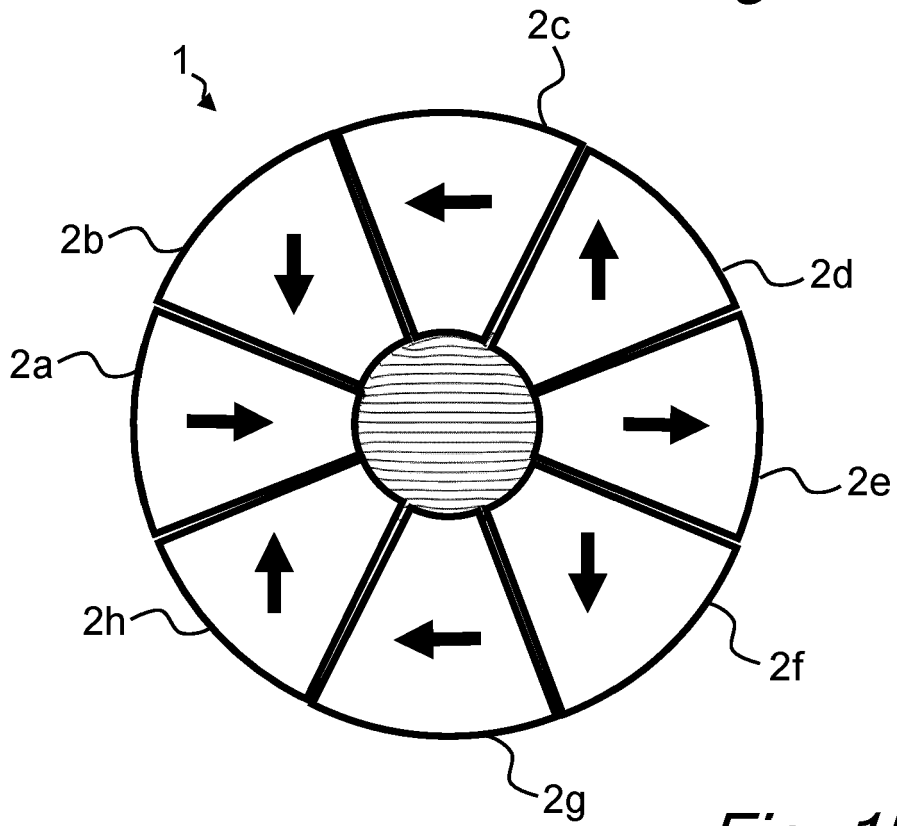
a sample holder, configured to hold a sample of a composite material, the composite material comprising the matrix material with randomly oriented micro- or nanoparticles, 35  
a cylindrical Halbach array of magnets, the cylindrical Halbach array comprising a plurality of separate magnets arranged concentrically around a central space, and 40  
an actuator to provide a relative movement between the sample holder and the Halbach array, to bring the composite material sample into and out of the central space of the cylindrical Halbach array. 45

50

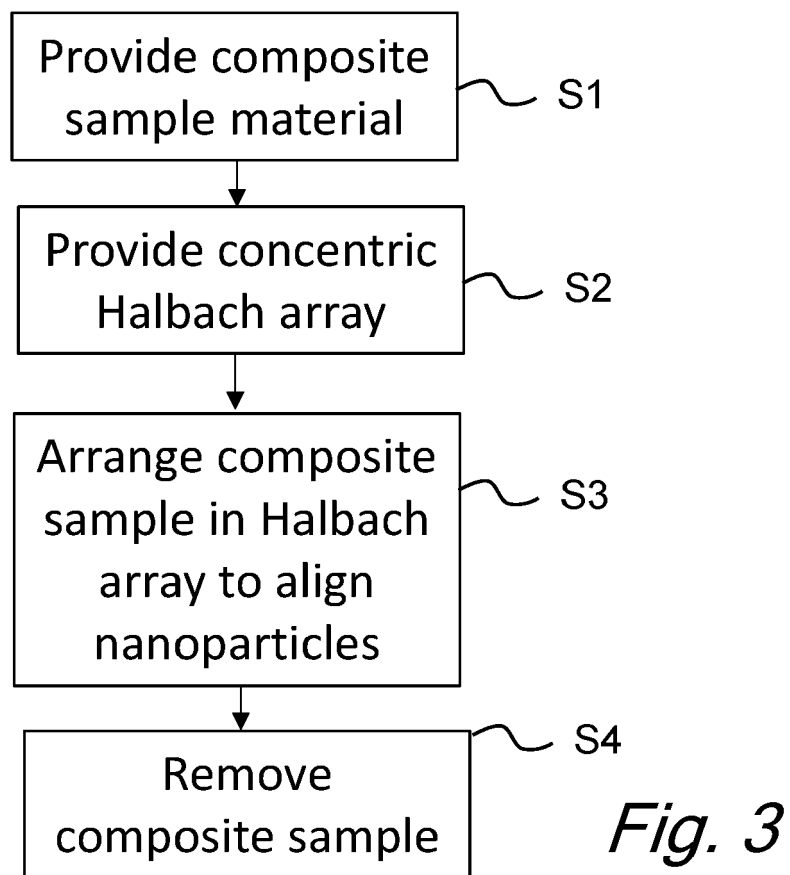
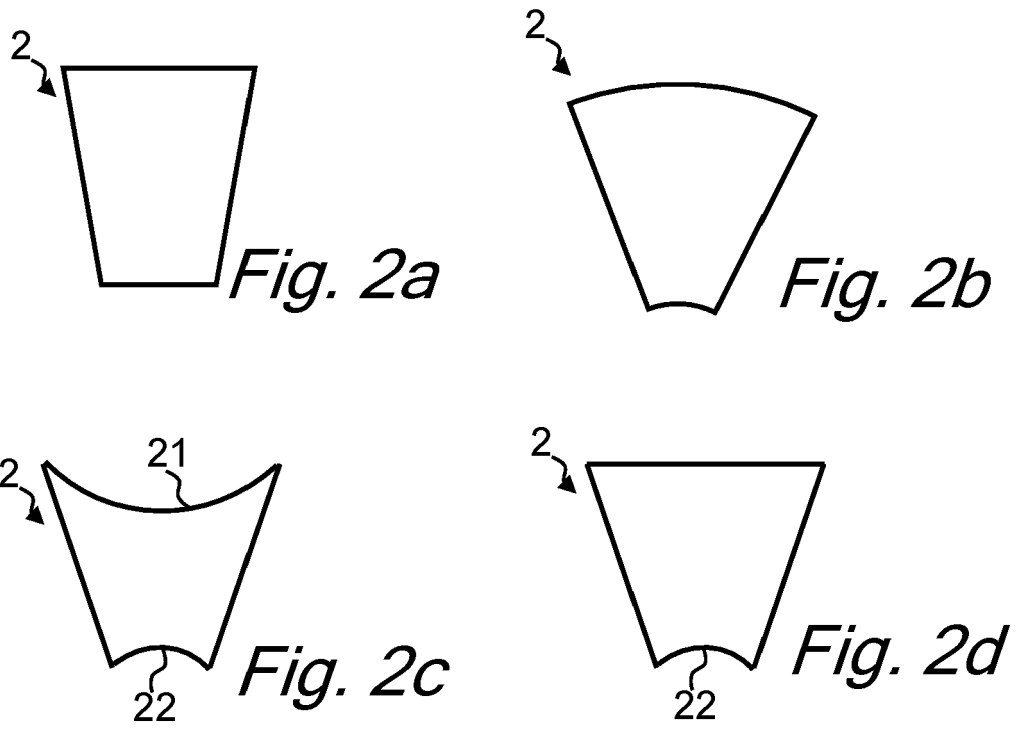
55

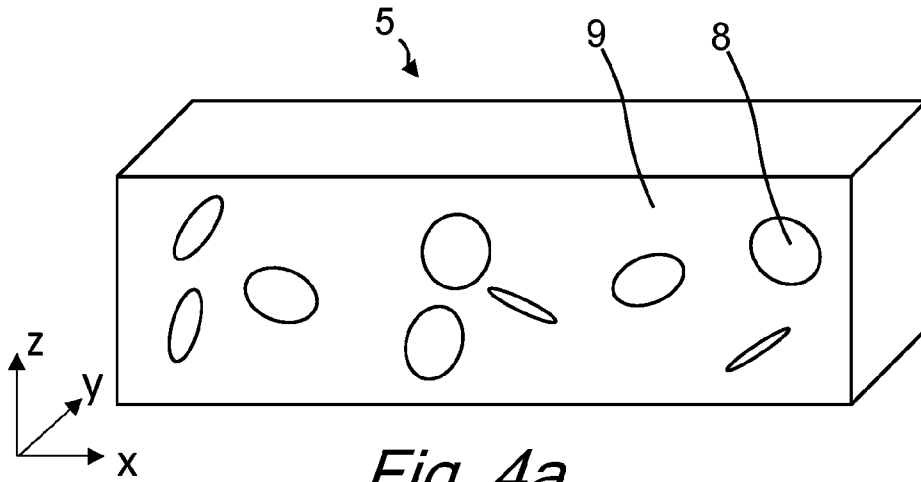


*Fig. 1a*

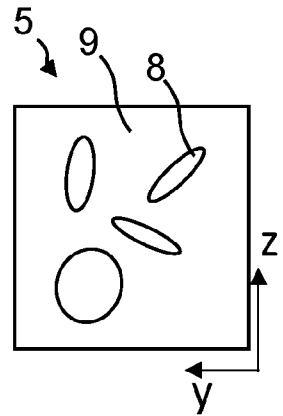


*Fig. 1b*

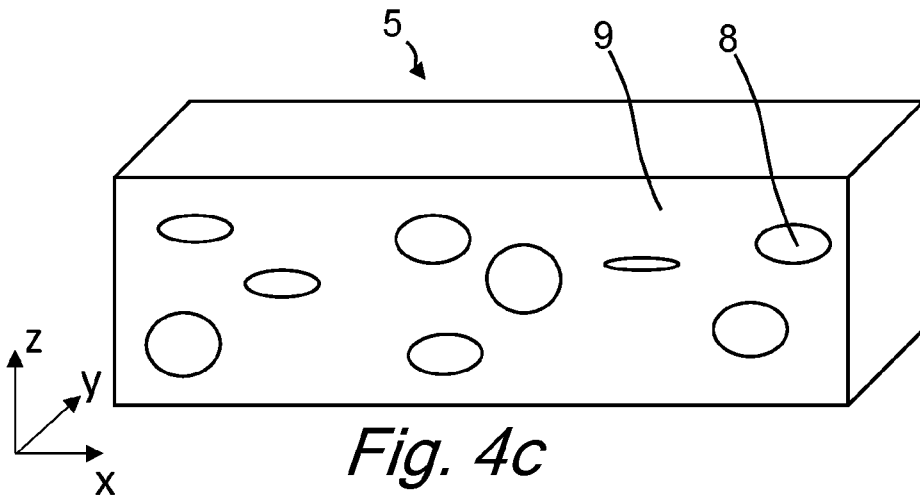




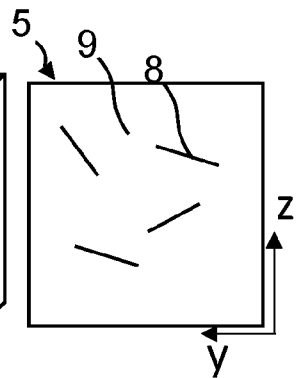
*Fig. 4a*



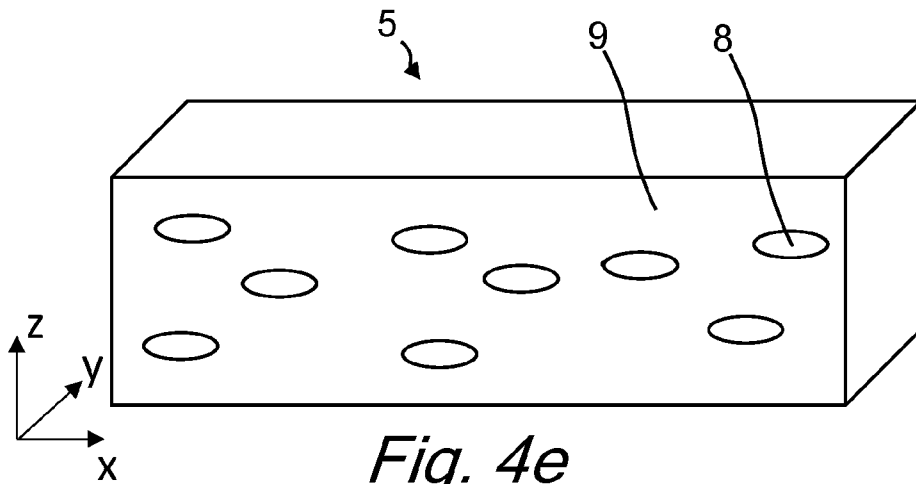
*Fig. 4b*



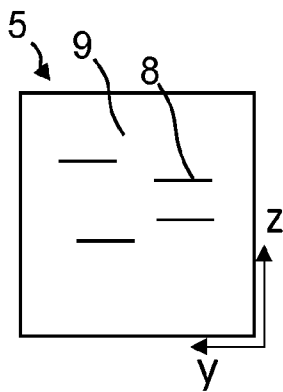
*Fig. 4c*



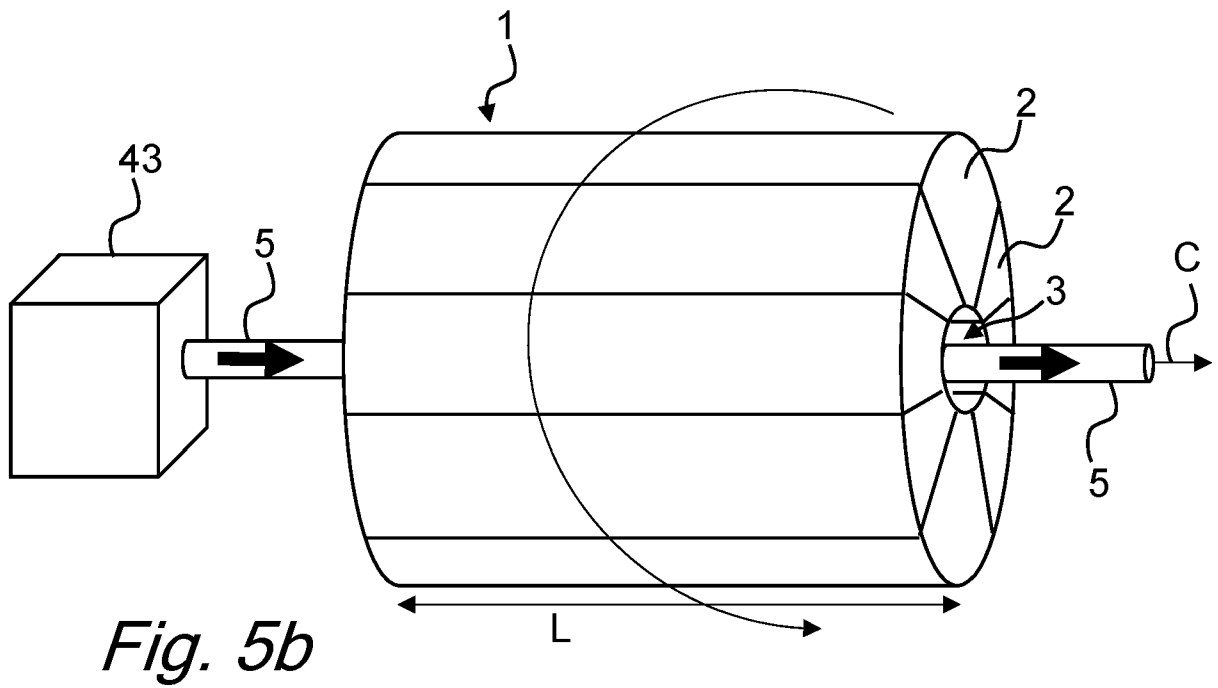
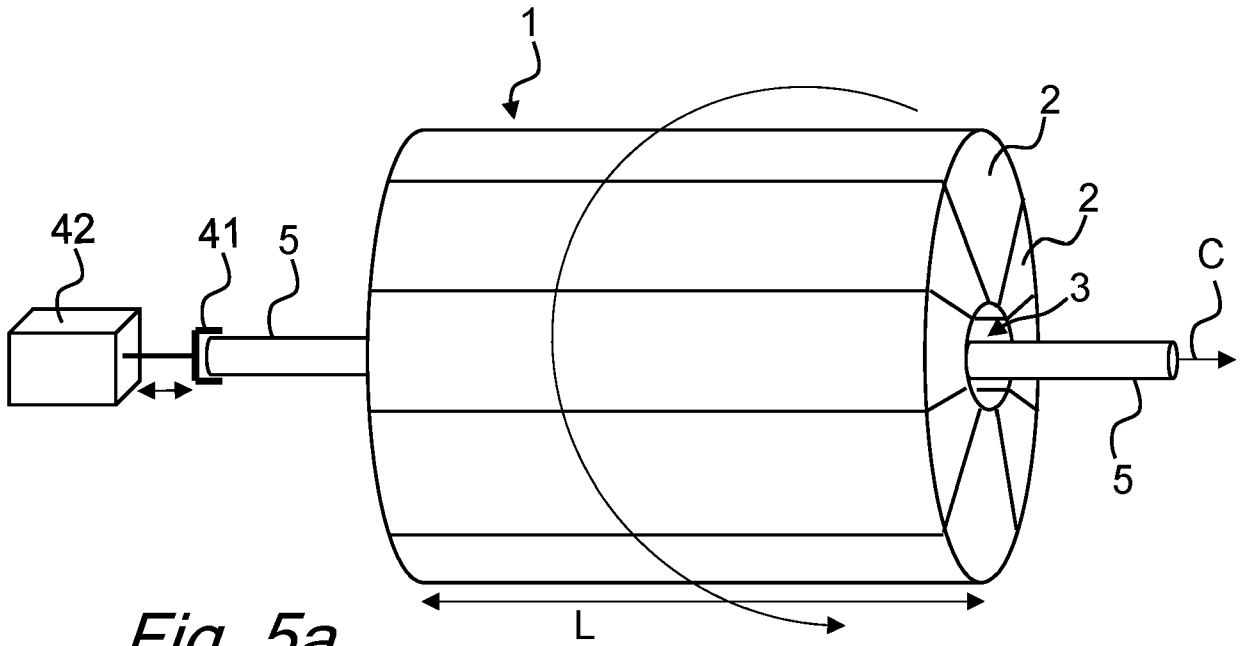
*Fig. 4d*

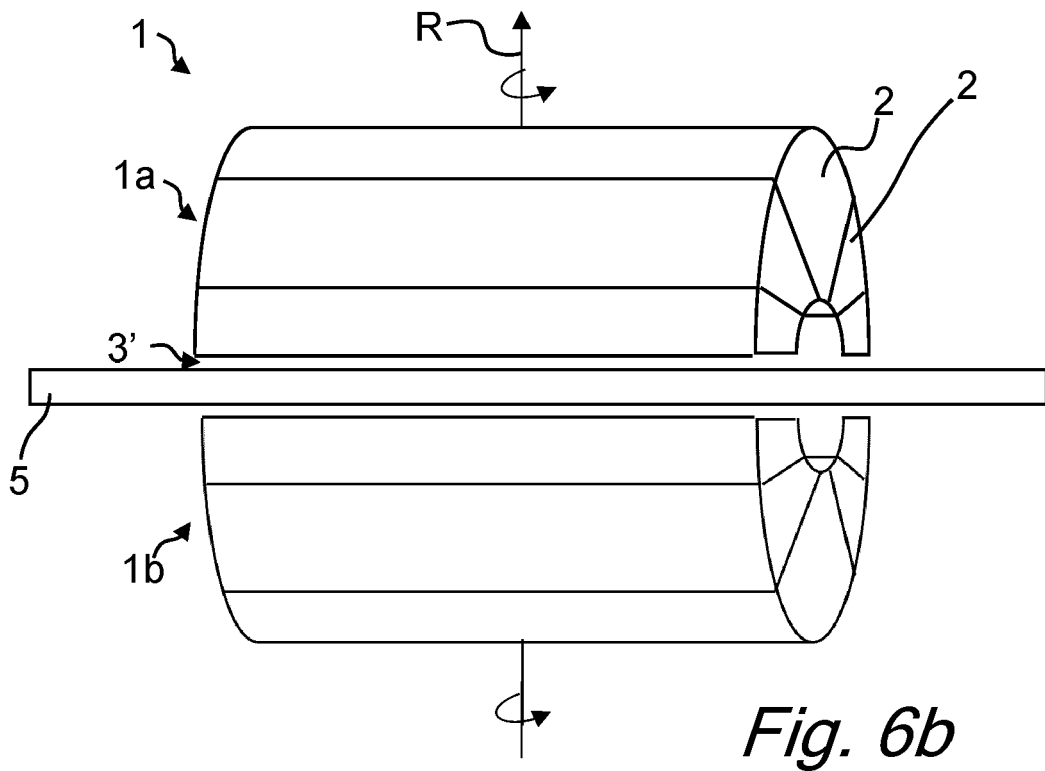
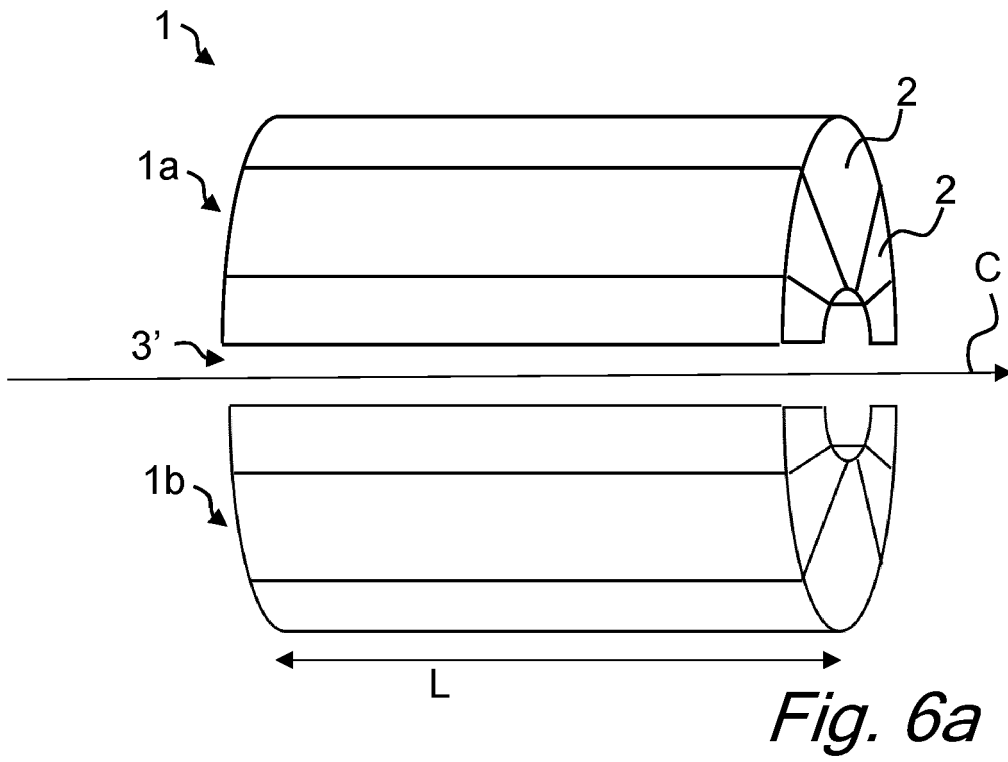


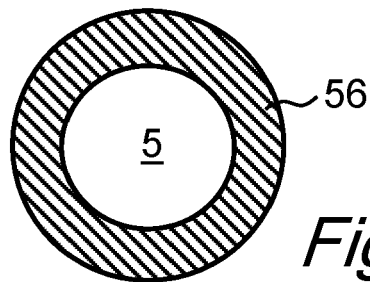
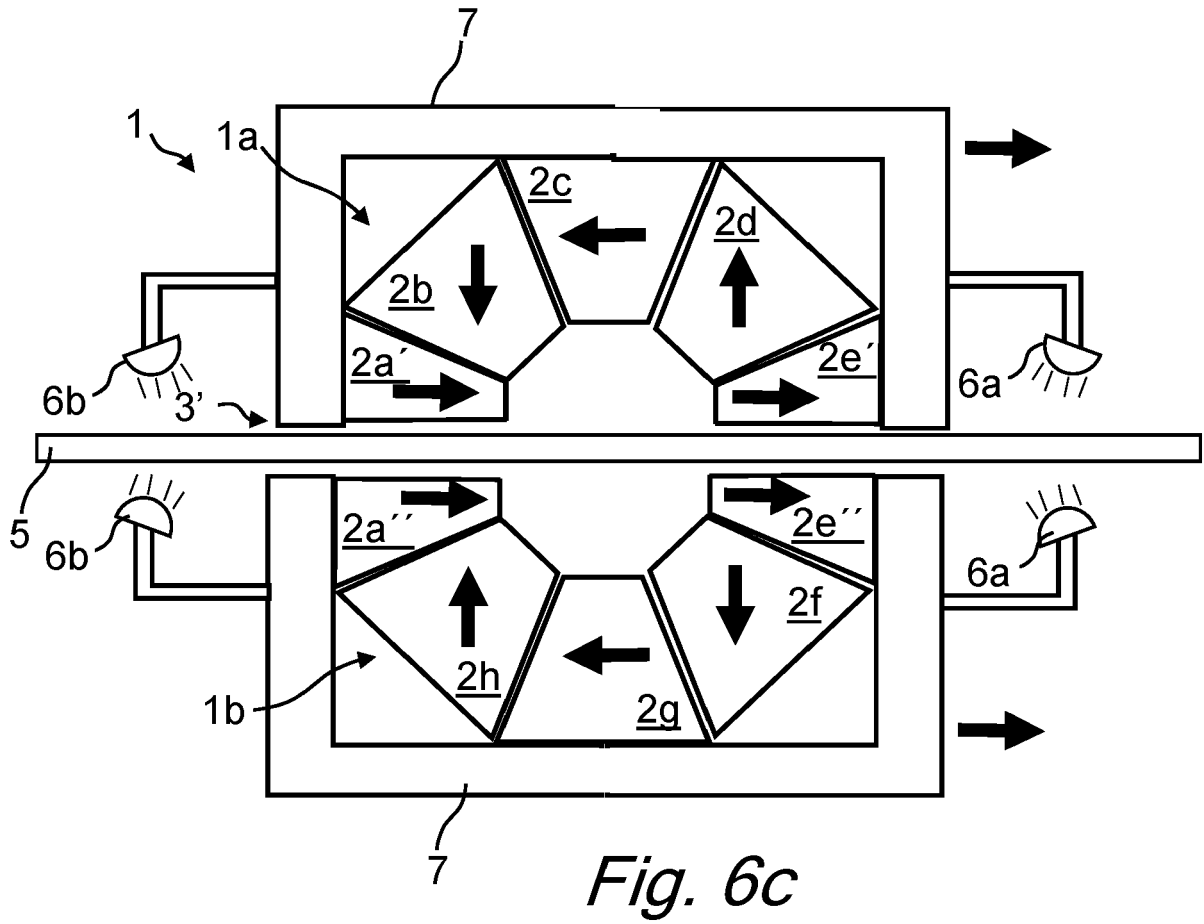
*Fig. 4e*

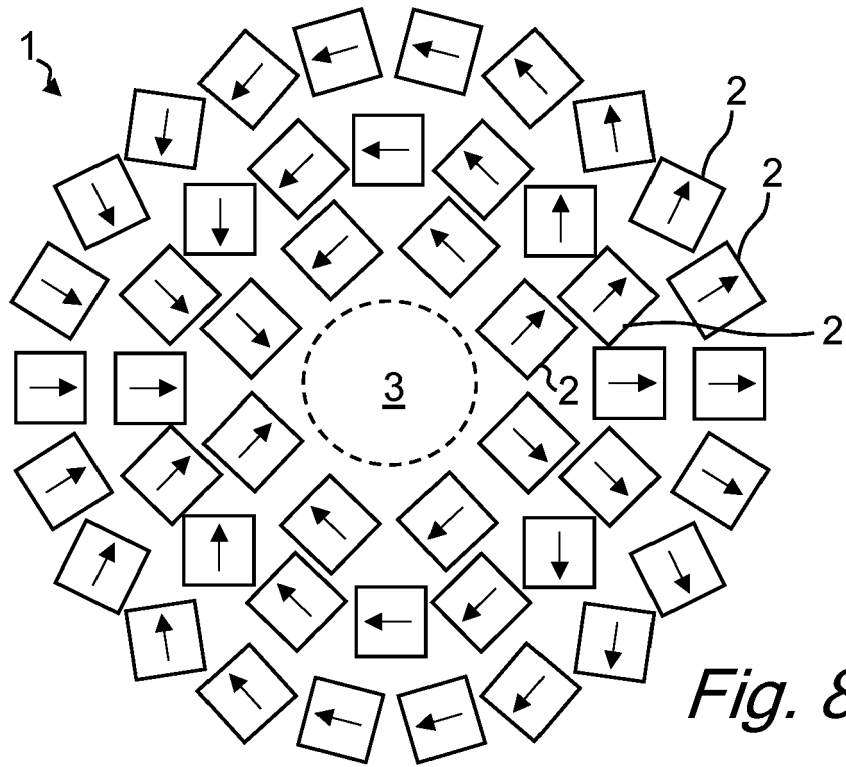


*Fig. 4f*

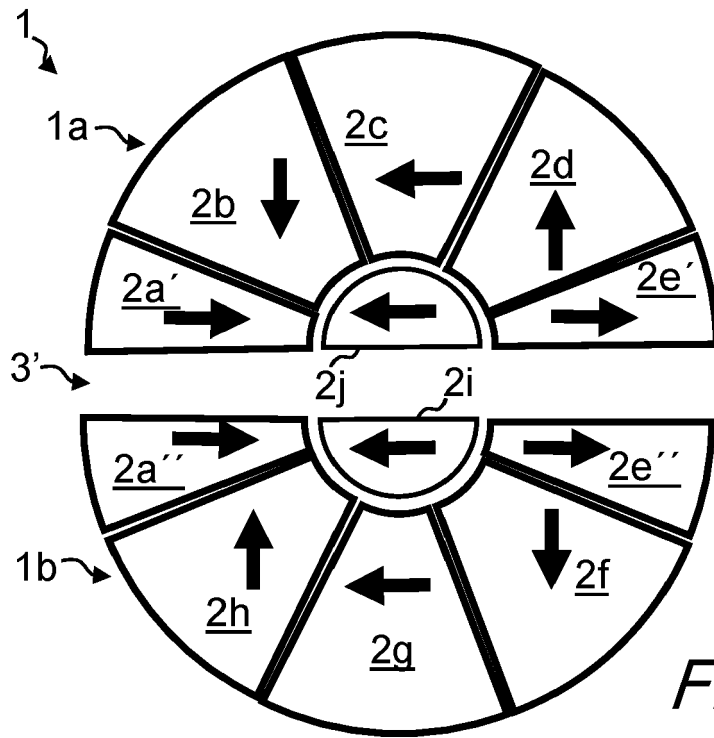




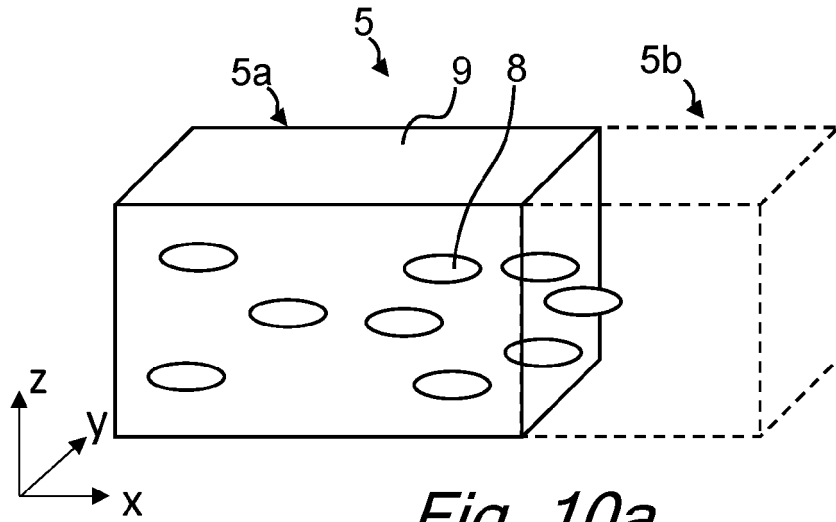




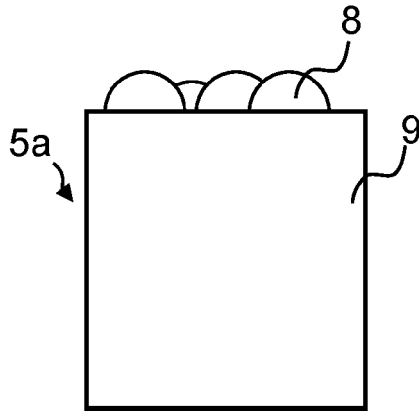
*Fig. 8*



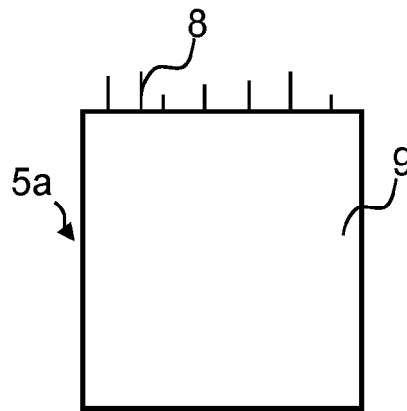
*Fig. 9*



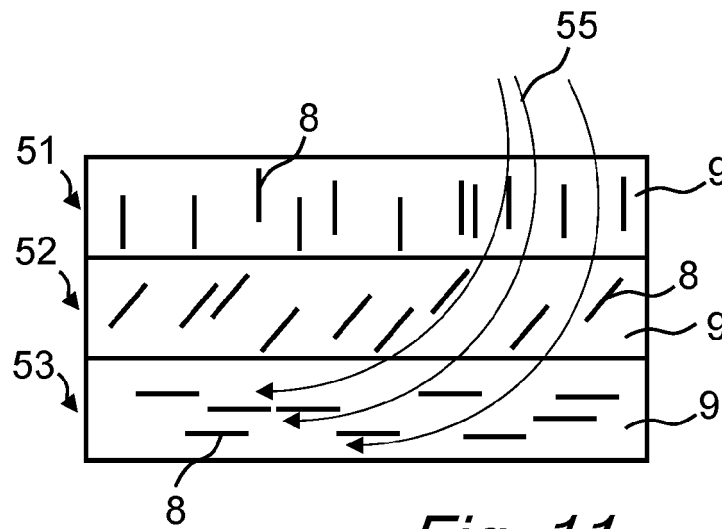
*Fig. 10a*



*Fig. 10b*



*Fig. 10c*



*Fig. 11*



EUROPEAN SEARCH REPORT

Application Number  
EP 23 22 0689

5

DOCUMENTS CONSIDERED TO BE RELEVANT

10

15

20

25

30

35

40

45

50

55

Category	Citation of document with indication, where appropriate, of relevant passages	Relevant to claim	CLASSIFICATION OF THE APPLICATION (IPC)
X	US 6 149 857 A (MCARDLE CIARAN B [IE] ET AL) 21 November 2000 (2000-11-21)	1-8,13, 15-19	INV. H01F7/02
Y	* the whole document *	7-12,14, 18	H01F1/00 H01F41/02
-----			
X	US 2017/001388 A1 (HEMMEN HENRIK [NO]) 5 January 2017 (2017-01-05)	1-8, 15-17	
Y	* the whole document *	7-12,14, 18	
-----			
X	EP 3 711 949 A1 (UNIV VIENNA [AT]) 23 September 2020 (2020-09-23)	1,2,7,8, 15,17,18	
Y	* the whole document *	7-12,14, 18	
-----			
X	WO 2016/083259 A1 (SICPA HOLDING SA [CH]) 2 June 2016 (2016-06-02)	1,2,7,8, 13-15, 18,19	
Y	* the whole document *	7-12,14, 18	
-----			
Y	COEY J M D ED - DEMPSEY NORA ET AL: "Permanent magnet applications", JOURNAL OF MAGNETISM AND MAGNETIC MATERIALS, ELSEVIER, AMSTERDAM, NL, vol. 248, no. 3, 1 August 2002 (2002-08-01), pages 441-456, XP004381285, ISSN: 0304-8853, DOI: 10.1016/S0304-8853(02)00335-9 * the whole document *	7-12,18	TECHNICAL FIELDS SEARCHED (IPC) H01F
-----			
-/--			
-----			
The present search report has been drawn up for all claims			
Place of search <b>Munich</b>		Date of completion of the search <b>31 May 2024</b>	Examiner <b>Van den Berg, G</b>
CATEGORY OF CITED DOCUMENTS X : particularly relevant if taken alone Y : particularly relevant if combined with another document of the same category A : technological background O : non-written disclosure P : intermediate document		T : theory or principle underlying the invention E : earlier patent document, but published on, or after the filing date D : document cited in the application L : document cited for other reasons ..... & : member of the same patent family, corresponding document	

EPO FORM 1503 03.82 (F04C01)



EUROPEAN SEARCH REPORT

Application Number  
EP 23 22 0689

5

10

15

20

25

30

35

40

45

50

55

DOCUMENTS CONSIDERED TO BE RELEVANT			
Category	Citation of document with indication, where appropriate, of relevant passages	Relevant to claim	CLASSIFICATION OF THE APPLICATION (IPC)
A	ZHU Z Q ET AL: "Powder Alignment System for Anisotropic Bonded NdFeB Halbach Cylinders", IEEE TRANSACTIONS ON MAGNETICS, IEEE, USA, vol. 36, no. 5, 1 September 2000 (2000-09-01), XP011033307, ISSN: 0018-9464 * the whole document *	1-19	
A	US 2005/239948 A1 (HAIK YOUSEF [US] ET AL) 27 October 2005 (2005-10-27) * the whole document *	1-19	
			TECHNICAL FIELDS SEARCHED (IPC)
The present search report has been drawn up for all claims			
Place of search <b>Munich</b>		Date of completion of the search <b>31 May 2024</b>	Examiner <b>Van den Berg, G</b>
CATEGORY OF CITED DOCUMENTS X : particularly relevant if taken alone Y : particularly relevant if combined with another document of the same category A : technological background O : non-written disclosure P : intermediate document		T : theory or principle underlying the invention E : earlier patent document, but published on, or after the filing date D : document cited in the application L : document cited for other reasons ..... & : member of the same patent family, corresponding document	

1  
EPO FORM 1503 03.82 (F04C01)

ANNEX TO THE EUROPEAN SEARCH REPORT  
ON EUROPEAN PATENT APPLICATION NO.

EP 23 22 0689

5

This annex lists the patent family members relating to the patent documents cited in the above-mentioned European search report. The members are as contained in the European Patent Office EDP file on The European Patent Office is in no way liable for these particulars which are merely given for the purpose of information.

31-05-2024

10

15

20

25

30

35

40

45

50

55

Patent document cited in search report	Publication date	Patent family member(s)	Publication date
US 6149857 A	21-11-2000	BR 9603241 A	28-04-1998
		CA 2182432 A1	02-02-1997
		EP 0757407 A1	05-02-1997
		JP H09134814 A	20-05-1997
		US 5851644 A	22-12-1998
		US 6149857 A	21-11-2000
-----			
US 2017001388 A1	05-01-2017	EP 3084780 A1	26-10-2016
		US 2017001388 A1	05-01-2017
		WO 2015091999 A1	25-06-2015
-----			
EP 3711949 A1	23-09-2020	EP 3711949 A1	23-09-2020
		WO 2020188009 A1	24-09-2020
-----			
WO 2016083259 A1	02-06-2016	AU 2015352705 A1	09-03-2017
		BR 112017005092 A2	23-01-2018
		CA 2962135 A1	02-06-2016
		CN 106999979 A	01-08-2017
		EP 3224055 A1	04-10-2017
		ES 2694558 T3	21-12-2018
		JP 6620340 B2	18-12-2019
		JP 2018506445 A	08-03-2018
		KR 20170092527 A	11-08-2017
		RU 2017113570 A	23-10-2018
		US 2017305184 A1	26-10-2017
		WO 2016083259 A1	02-06-2016
		ZA 201701296 B	28-08-2019
-----			
US 2005239948 A1	27-10-2005	NONE	
-----			

EPO FORM P0459

For more details about this annex : see Official Journal of the European Patent Office, No. 12/82