

May 9, 1933.

A. HABERSTUMP

1,908,343

AUTO DOORLATCH

Filed Oct. 13, 1930

2 Sheets-Sheet 1

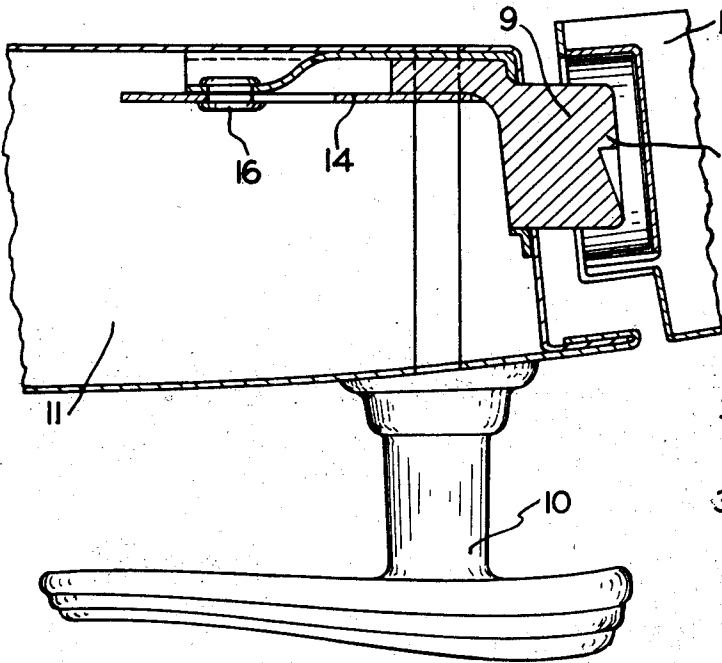

Fig. 1.

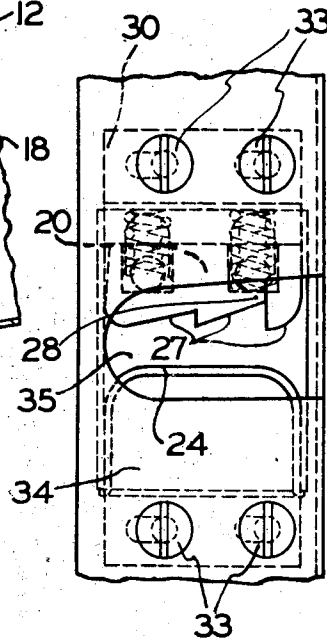

Fig. 3.

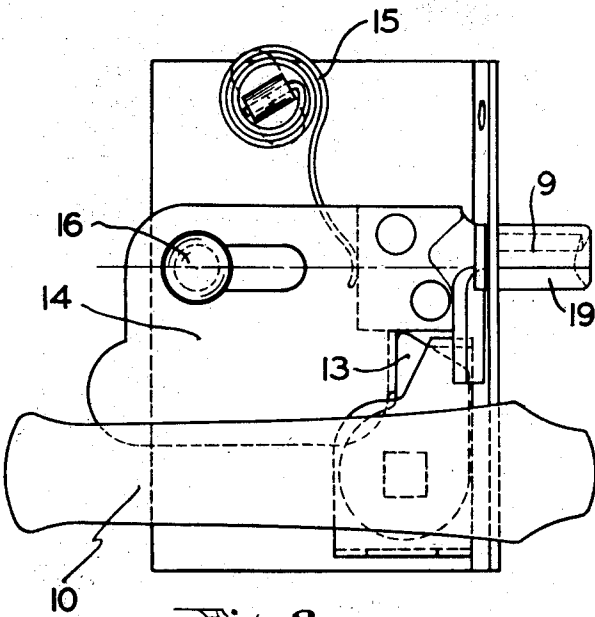

Fig. 2.

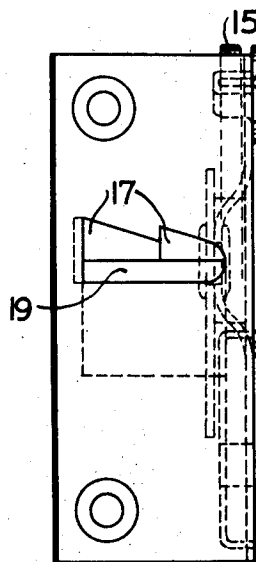

Fig. 4. Inventor
Alfred Haberstump
By - Liverance and
Van Antwerp
Attorneys

May 9, 1933.

A. HABERSTUMP

1,908,343

AUTO DOORLATCH

Filed Oct. 13, 1930

2 Sheets-Sheet 2

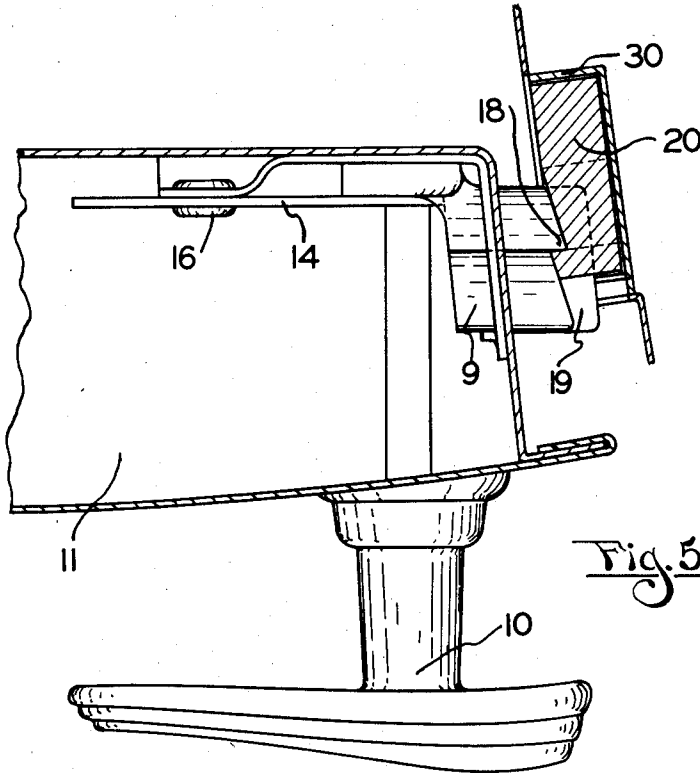

Fig. 5.

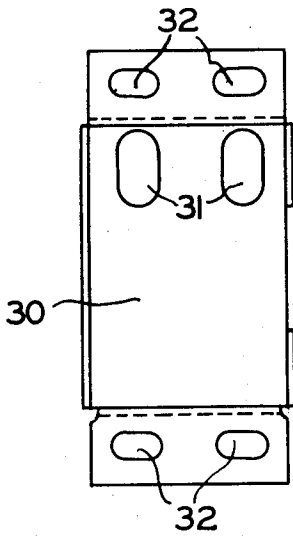

Fig. 6.

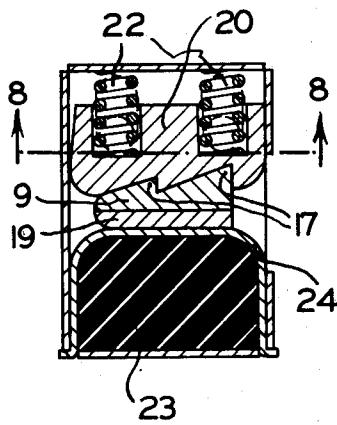

Fig. 7.

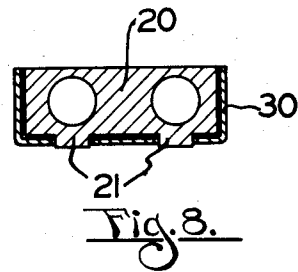

Fig. 8.

Inventor
Alfred Haberstump
By Liverance and
Van Antwerp
Attorneys

UNITED STATES PATENT OFFICE

ALFRED HABERSTUMP, OF GRAND RAPIDS, MICHIGAN

AUTO DOORLATCH

Application filed October 13, 1930. Serial No. 488,269.

My invention relates generally to latches and more particularly to a latch adapted to be applied to the usual swinging type of automobile door.

5 One defect of doors for automobiles, as at present manufactured, is that the lugs which protrude from the edge of the door and which seat in tapered recesses in the frame portion of the body member, tend to wedge 10 in position when the door is forcibly closed and thus hinder the door from being readily opened. That is to say, these projecting and interengaging lugs, commonly known as "dovetails", serve to maintain the door in 15 such position when it is closed that the latch member is located directly opposite its keeper. Also, the engagement of the male and female parts holds the door firmly away from the top and bottom sills of the door 20 and eliminates any up and down movement when the body of the automobile is distorted by any cause.

Another defect now existent is that it is necessary to manufacture this guiding device, entirely separate from the intermediate 25 latching member. In other words the several parts are entirely separate and distinct from each other and must be applied separately both to the door and its frame and 30 hence are more expensive to use.

Now, in my improved device I obviate and overcome the above recited disadvantages as well as obtain several meritorious features which will herein be set forth and which 35 will be readily understood from a reading of the instant specification.

Briefly described, my invention consists of a rigid member or arm which protrudes from the swinging door and which enters 40 a slot in the keeper member. Immediately above this arm is my novel latch member which is slotted both on its upper edge and along its end, the top slots serving to hold the door in a closed position when it is 45 pushed shut without turning the handle member and the end notch serving to be engaged by a projection on the keeper member when the door is pushed shut while the handle member is held with the latching 50 bolt retracted during the closing thereof

and after closing the handle is released. The first referred to notches engage the vertical sliding member in the keeper unit when the door is properly closed while the notch in the end of the latching element engages when the door is improperly closed. 55

Another feature or advantage of my device is that the rigid member which extends from the door not only serves to guide the door to its proper closed position, as other 60 devices of this character likewise do, but no difficulty is had in releasing the same because the latch member, slidably engaged thereon, is adapted to be withdrawn by turning the handle on the door whenever releasing and opening of the door is desired. 65 Therefore, the rigid guide member is freely released.

Another advantage which I obtain is a cheapened construction over those previously 70 manufactured without losing any of the desirable or necessary results previously obtained. I accomplish this by combining the two devices usually used into a single 75 device is integrally formed with the latching mechanism. Furthermore, the latch, being placed about one-half way upon the door, allows for the symmetrical locating of the 80 guiding member.

Other objects will become apparent from the following description taken in connection with the accompanying drawings, in which,

Fig. 1 is a horizontal sectional view taken 85 through the body of an automobile showing my invention applied to the door thereof.

Fig. 2 is a side view of Fig. 1, certain parts being broken away in order to expedite the disclosure. 90

Fig. 3 is a view looking at the face of the keeper.

Fig. 4 is a side view of Fig. 2.

Fig. 5 is a view similar to Fig. 1 but with 95 the door shown in a position caused by the failure to release the latch until after the door was in its inner position.

Fig. 6 is a side view of the casing or housing for the keeper mechanism. 100

Fig. 7 is a vertical cross section through the keeper mechanism, and

Fig. 8 is a view taken along the line 8—8 of Fig. 7.

5 Like numerals refer to like parts in the several figures of the drawings.

As shown in Figs. 1, 2 and 5, 10 indicates the handle member of the door 11 which is hingeably mounted upon the main body 12 of an automobile. A member 13, rigid with the handle member, see Fig. 2, cams against the slide 14 and retracts it against the action of the spring 15, this slide being held in place by the headed rivet 16. The outer end 9 of the slide 14 extends through the edge of the door as clearly shown in the drawings and is formed with teeth 17 on its upper or top surface, while a vertical tooth 18 is formed on its outer end. A rigid extension 19 extends from the door immediately below the latch bolt or element and supports the same. The end of the latch bolt or element lies substantially even with the end of the supporting means 19 when the door is in its properly located position.

The structure just set forth operates in the usual manner. That is, by turning the handle 10, the member 13 rides against the sliding structure 14 and retracts it against the action of the spring 15, thus moving the outer end 9 to the left and disengaging the teeth 17 from contact with the keeper slide member 20.

The keeper slide member is constrained to move in a predetermined vertical path in the casing member 30 due to lugs 21 extending therefrom and riding in the grooves 31 of the casing. Springs 22, see Fig. 7, force the keeper member downwardly.

40 A rubber pad 23 rests in the casing at the bottom thereof and yieldably engages the extension 19 when the automobile door is swung shut. A shell 24 protects the rubber and extends through the bottom of the casing as clearly shown in Fig. 7, thus permitting the rubber to compress, if necessary.

The casing member has slots 32 near its top and bottom adapted to receive bolts 33 which extend into the frame of the automobile and maintain the keeper unit in place. A plate 34 forms the front or cover of the casing member and is cut away as at 35 in order to provide a path for the latching element.

55 The operation of my device is readily understood. Assuming the door to be open one grasps the handle and without turning the handle pushes the door to its inner position, thus causing the teeth 17 to ride underneath the several sloping surfaces 27, formed on the bottom of the element 20, see Fig. 3, and thus pushing the same upwardly against the action of the springs 22. However, as soon as the door is fully shut these 65 springs cause the teeth 17 to be engaged as

shown in Fig. 7 and prevent the door from swinging open. At the same time that the above occurs the rigid member 19 contacts with the metal member 24 and rides thereagainst and thus causes the latch to exactly 70 correspond in position with its keeper member. When one desires to release the door from its closed position the handle 10 is rotated and withdrawal of the latching element occurs. During this withdrawal the 75 rigid member 19 becomes loose and unwedged and hence no difficulty whatsoever is had in opening the door.

Should one improperly close the door by rotating the handle 10 with a corresponding withdrawal of the latching element inwardly into the door in which it operates, the tooth 18 will tend to contact with the groove 28 thus preventing the door from opening but yet failing to maintain the door in its 85 fully closed position. Thus one will be aware of the fact that proper closing has not occurred and will again open the door and push it shut without turning the handle 10, thus obtaining proper holding of the door 90 in its closed position. It is true that the spring 15 tends to push the slide 14 inwardly so that the latching element would slide home to its proper position but ordinarily the spring 15 is not powerful enough to accomplish this effect. However, the outer 95 edges of the keeper member 20 are slightly rounded and oftentimes proper closing of the door is had without the above manipulation. 100

It will be observed that, in the device as described above, the latch bolt functions in the space between the opposed resiliently supported clamping members or elements or, as defined in the appended claims, the wedging zone or zone of wedging action, this arrangement being advantageous in that it permits great economy of space and simplicity of design, thus facilitating manufacture, lowering cost, and providing a device 110 which can be applied readily to the door and door frame members of a vehicle without making any material changes therein or substantial departures from standard practice. 115

Having thus revealed this invention, I claim as new and desire to secure the following combinations and elements or equivalents thereof, by Letters Patent of the United States. 120

What I claim is:

1. A latch for automobile doors comprising a spring pressed slidably mounted latch member having a notch formed therein at an angle to the path of movement of the same in its sliding movements, a keeper adapted to slide into said notch to maintain the door in stationary position and additional means adapted to hold the door stationary when the spring adapted to press the latch member outwardly is rendered ineffective. 125 130

2. A closure fastener device between two members adapted to be moved into aligned position comprising a latch element extending from one of said members, means to force the latch element outwardly, means to withdraw the latch element inwardly, said other member having a recess to receive the latch element and means adjacent said recess adapted to act upon the latch element to secure the same regardless of whether the latch element is in its outer or inner position.

3. A device having the elements in combination as set forth in claim 2, and also having rigid means extending from the member having the latch element mounted thereon, said rigid means being adapted to support the latch element when in its extended position.

4. A device having the elements in combination as set forth in claim 2, and also having rigid means extending from the member having the latch element mounted thereon, said rigid means being adapted to support the latch element when in its extended position and guiding means in the aforesaid recess adapted to act upon the rigid means to properly position the latch element.

5. The combination for use with a door frame member and a door member hinged to swing laterally with respect to the frame member, of wedging means adapted to be secured on one of said members and a wedge-receiving means adapted to be secured on the other member, one of said means having a pair of oppositely disposed elements relatively bodily movable and having contact surfaces complementary with respect to surfaces of the other of said means, portions of said means respectively, located in the wedging zone, comprising mutually engageable and releasable latching devices.

6. The combination for use with a door frame member and a door member hinged to swing laterally with respect to the frame member, of wedging means adapted to be secured on one of said members and a wedge-receiving means adapted to be secured on the other member one of said means having a pair of oppositely disposed elements relatively bodily movable and having contact surfaces complementary with respect to surfaces of the other of said means, a portion of the wedging means being movable relatively to the remainder thereof and comprising a latch bolt and a portion of the wedge-receiving means comprising a retainer therefor, said portions being located in the wedging zone.

7. The combination for use with a door frame member and a door member hinged to swing laterally with respect to the frame member, of wedging means adapted to be secured on one of said members and a wedge-receiving means adapted to be secured on

the other member, one of said means having a pair of oppositely disposed elements relatively bodily movable and having contact surfaces complementary with respect to the surfaces of the other of said means, a portion of the wedging means being slidable relatively to the remainder, which is fixed, and comprising a latch bolt, and a portion of the wedge-receiving means comprising a retainer therefor, retraction of the latch bolt disengaging it from the retainer and breaking the wedging engagement of said means.

8. The combination for use with a door frame member and a door member hinged to swing laterally with respect to the frame member, of a multiple part wedging means adapted to be secured on one of said members and a wedge-receiving means adapted to be secured on the other member, said wedge-receiving means comprising two opposed elements relatively bodily movable and having contact surfaces complementary with respect to the surfaces of the wedging means, a portion of the wedging means, adapted to engage one of said elements when the door is closed, being retractable so as to disengage said element and thereby break the wedging engagement of said means.

9. The combination for use with a door frame member and a door member hinged to swing laterally with respect to the frame member, of a multiple part wedging means adapted to be secured on one of said members and a wedge-receiving means adapted to be secured on the other member, said wedge receiving means comprising two opposed bodily movable elements having contact surfaces complementary with respect to the surfaces of the wedging means, that portion of the wedging means which engages one of said elements comprising a latch bolt and being retractable so as to disengage the said element, thereby unlatching said wedging means and simultaneously breaking the wedging engagement therebetween.

10. The combination for use with a door frame member and a door member hinged to swing laterally with respect to the frame member, of a multiple part wedging means adapted to be secured on one of said members and comprising upper and lower portions, the upper portion being retractable, and a wedge-receiving means adapted to be secured on the other member comprising upper and lower opposed bodily movable elements having contact surfaces complementary with respect to the surfaces of the wedge-shaped element, the upper portion of the wedging means being adapted to interlock with the upper element on the wedge-receiving means when the door is closed and to be retracted so as to disengage the said element, thus breaking the interlock between

said means and the wedging engagement therebetween.

11. The combination for use with a door frame member and a door member hinged to swing laterally with respect to the frame member, of wedging means secured on one of said members and having a smooth lower surface and a toothed upper surface, the upper tooth-carrying portion of said means being retractable, and a wedge-receiving means on the other member comprising upper and lower opposed elements bodily movable relatively to each other and having contact surfaces complementary with respect to the surfaces of the wedging means, the lower face of the upper element having a tooth adapted to interlock with the tooth of the upper portion of the wedging means and the upper face of the lower element being smooth, retraction of the tooth-carrying portion of the wedging means breaking the interlock between said means and the wedging engagement therebetween, permitting free disengagement thereof.

12. The combination for use with a door frame member and a door member hinged to swing laterally with respect to the frame member, of a combined wedging and latching means adapted to be secured on one of said members and a wedge-receiving means adapted to be secured on the other member, said wedge-receiving means including two opposed relatively movable and resiliently supported elements adapted to tightly clamp between them and resiliently support the first mentioned means, one of said elements being provided with a retainer located in the wedging zone.

13. The combination for use with a door frame member and a door member hinged to swing laterally with respect to the frame member, a combined wedging and latching means projecting laterally from one of said members, and a combined wedge-receiving and retaining means mounted on the other member, said last mentioned means being provided with elements to resiliently clamp between them the first mentioned means, the mutually interlocking portions of said means being located in the zone of wedging action when the door is closed.

14. The combination for use with a door frame member and a door member hinged to swing laterally with respect to the frame member, of a retractable latch bolt and a door supporting arm projecting from the door, the latch bolt being slidably and non-rotatably carried by the arm, and a keeper mounted on the frame and provided with spaced relatively movable means adapted to receive between them and tightly clamp the arm and latch bolt, one of said means having a catch to cooperate with the latch bolt.

In testimony whereof I affix my signature.

ALFRED HABERSTUMP.