

Fig. 1

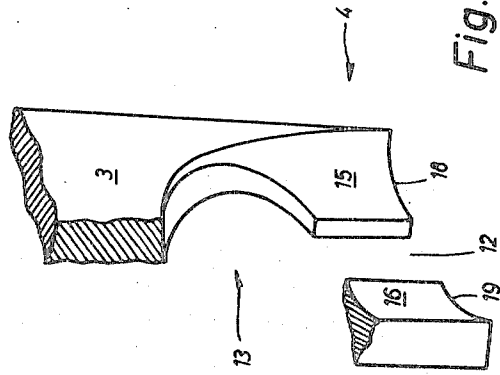

Fig. 6

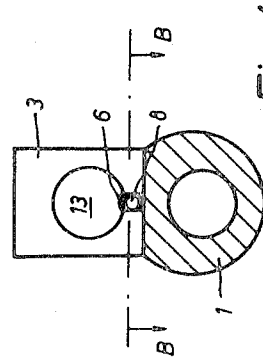

Fig. 4

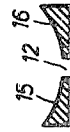

Fig. 5

INVENTOR

BRUNO STAIGER

BY *Sung Ki Lee*

ATTORNEY

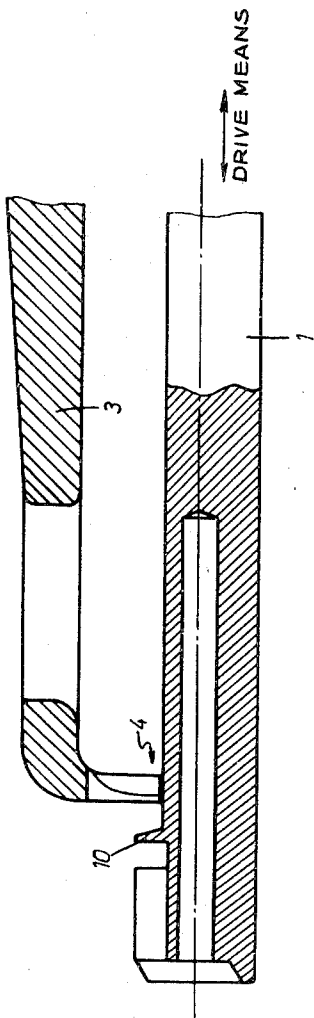

Fig. 2

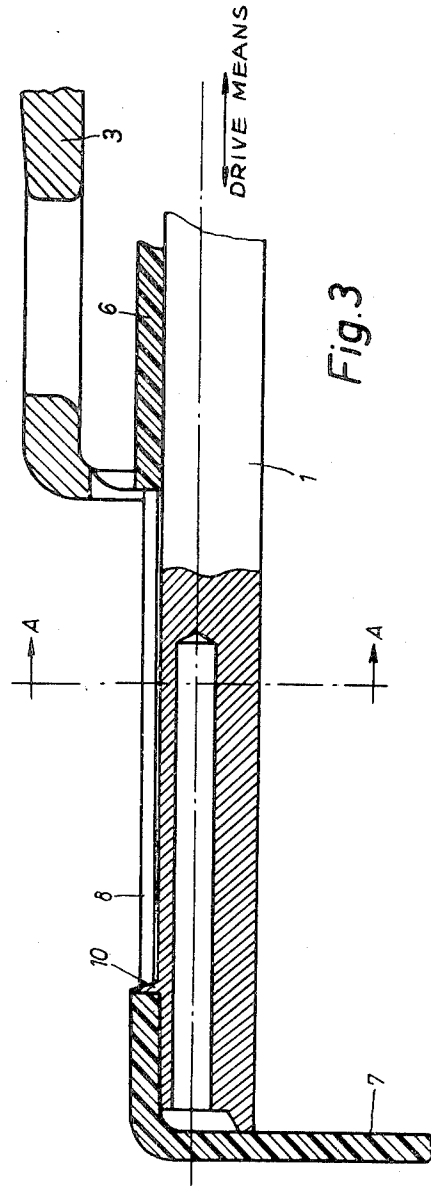

Fig. 3

INVENTOR

BRUNO STAIGER

BY *Sang Ki Lee*

ATTORNEY

WIRE STRIPPING AND WRAPPING GUN

BACKGROUND OF THE INVENTION

1. Field of the Invention

The present invention relates to a wire stripping and wrapping gun or tool for cutting and stripping wires, as well as for making wire-wrap joints, and, more particularly, to an improved cutting edge in the knife provided in such a gun or tool.

2. Description of the Prior Art

Prior art, such as the copending U.S. Pat. application Ser. No. 851,847, filed on Aug. 21, 1969, and assigned to the same assignee as the instant application, shows a wire stripping and wrapping gun for cutting and stripping of the insulation from the wire, as well as, for producing wire-wrap joints. The gun includes a wrapper pin slidably mounted within a centrally and axially apertured wrapper sleeve for imparting the wrapping and stripping movement, and a lever knife with the cutting edge thereof pivotally mounted on the wrapper sleeve. As the wrapper pin is axially moved the cutting edge is lowered upon the wire against an upstanding portion of the wrapper pin positioned therebelow, and cuts the insulation on both sides and, in the course of a further axial movement, the insulation is stripped from the wire.

According to the wire stripping and wrapping gun shown in the aforementioned copending application, the lever knife has a simple straight cutting edge. It has been found that the straight cutting edge cuts the edges of the insulation only partially and does not readily remove the stripped insulation.

SUMMARY OF THE INVENTION

It is an object of the present invention to provide an improved wrapping and stripping tool in general and, in particular, to provide an improved cutting edge in the lever knife to overcome the aforementioned shortcomings.

This and other objects of the present invention are achieved by providing a channel in the cutting edge of the knife wide enough to receive the bare metal wire and a curved aperture contiguous therewith. The bifurcated cutting edge formed by the channel is designed to cut through both sides of the insulation of the wire completely, and the circular aperture prevents the insulation from being crimped or clamped along the cutting edge and piling up as it is being stripped.

It is a further feature of the present invention that the inner surface of the bifurcated cutting edge facing the insulation being stripped is concavely curved to further assure avoidance of the crimping and clamping and maintain mechanical stability of the cutting edge.

It is another feature of the present invention that the width of the channel is made to correspond to the diameter of the bare wire after the insulation has been stripped.

The novel configuration of cutting edge of the present invention assures clean cutting of the insulation without causing any damage to the bare wire, and prevents the portion of the insulation from piling up and jamming the lever knife to hinder the subsequent stripping operation.

BRIEF DESCRIPTION OF THE DRAWINGS

FIG. 1 shows a partially sectioned view of a portion of the wrapping and stripping gun including a wrapper sleeve and pin, a lever knife, and a portion of wire which is stripped,

FIG. 2 shows a side view of a portion of the wrapper pin and the lever knife,

FIG. 3 shows the arrangement according to FIG. 2 with the wire insulation partially stripped,

FIG. 4 shows a front view of the lever knife along section A—A in FIG. 3,

FIG. 5 shows a sectional view of the cutting edge along section B—B shown in FIG. 4, and

FIG. 6 shows a perspective view of the end of the lever knife shown in FIG. 4, with a portion thereof broken away to show

the surface configuration of the cutting edge.
DETAILED DESCRIPTION OF THE INVENTION

As shown in FIG. 1, a wrapping and stripping gun includes a wrapper pin 1, housed in a wrapper sleeve 2, and a lever knife 3 pivotally mounted on the sleeve such that one end of the knife rides on the pin. The other end of the knife is provided with a cutting edge 4.

A portion 5 of the pin surface is contoured such that the cutting edge follows a first position away from the wrapper pin 1 and a second position toward the pin, as a suitable preferably pneumatic actuating drive means indicated by an arrow, moves the wrapper pin 1 forward. In this manner, the insulation 6 of a wire 7 is cut and stripped away from the bare metal wire conductor 8.

FIG. 2 shows in detail how the lever knife 3, shown in a sectional representation, is lowered upon the wrapper pin 1. In this position the insulation of the wire is cut by the lever knife 3. In the course of the further operation of the wire stripping and wrapping gun, the wrapper pin 1 moves forward and the cutting edge of the lever knife 3 strips the insulation off the wire.

FIG. 3 shows the relative positions of the lever knife 3 and wrapper pin 1 after the lever knife has cut and stripped the insulation 6 from the bare metal conductor portion 8 of an insulated wire 7 inserted between the wrapper pin 1 and wrapper sleeve 2, in the course of the forward movement of the wrapper pin 1 in the direction along the axis shown by the arrow. The portion of the insulation which should remain on the wire 8, is retained by an upturned portion 10 of the wrapper pin 1.

FIGS. 4, 5 and 6 show the novel geometry of the end 4 of the lever knife and the cutting edge. As shown in FIG. 6, the end 4 includes a channel 12 and a preferably circular aperture 13 contiguous therewith. The two forks 15 and 16 have a concavely curved surface at the inner side facing the insulation being cut and stripped. It is preferred that the width of the channel be substantially equal to the diameter of the bare wire so that two portions 18 and 19 of the cutting edge at the tip ends of the two forks 15 and 16 cut the two sides of the insulation sharply and cleanly from the wire. Preferably, the diameter of the circular aperture is larger than the width of the channel. The circular aperture and the concavely apertured forks 15 and 16 relieve the pressure from the tip end of the insulation being cut, as the insulation is being stripped. This prevents the crimping and clamping which would otherwise build up in the insulation being stripped and cause the stripped insulation to jam against the two portions 18 and 19.

I claim:

1. A tool for cutting and stripping insulation from a wire conductor comprising: drive means for driving the wire in a longitudinal direction with respect to a central axis of said tool, an apertured sleeve disposed around said central axis, a pin disposed in said sleeve and coupled to said drive means to provide axial movement of said wire within said sleeve, and a lever knife pivotally mounted on said sleeve, and having a bifurcated cutting edge including a channel for receiving said wire and a curved aperture contiguous with said channel, said bifurcated cutting edge being disposed transversely to said wire, said pin having means for pivotally moving said knife and causing said cutting edge to extend through said apertured sleeve and cut said insulation upon axial displacement of said pin, said axial movement of said pin thereafter stripping the insulation from the wire.

2. The tool according to claim 1, wherein said curved aperture is circular and has a diameter larger than the width of said channel.

3. The tool according to claim 2, wherein the inner side of said cutting edge facing the stripped insulation is concavely curved.

4. The tool according to claim 3, wherein the width of said channel corresponds substantially to the diameter of said wire conductor with the insulation removed.

* * * * *