

(19)



(11)

**EP 2 091 060 A2**

(12)

**EUROPEAN PATENT APPLICATION**

(43) Date of publication:  
**19.08.2009 Bulletin 2009/34**

(51) Int Cl.:  
**H01H 61/01 (2006.01) H01H 61/02 (2006.01)**

(21) Application number: **08017805.6**

(22) Date of filing: **10.10.2008**

(84) Designated Contracting States:  
**AT BE BG CH CY CZ DE DK EE ES FI FR GB GR HR HU IE IS IT LI LT LU LV MC MT NL NO PL PT RO SE SI SK TR**  
Designated Extension States:  
**AL BA MK RS**

(72) Inventors:  
• **Tatsukawa, Masahiro**  
**Tokyo 191-8502 (JP)**  
• **Nakano, Masaaki**  
**Tokyo 191-8502 (JP)**  
• **Furuhata, Yukinari**  
**Tokyo 141-0032 (JP)**

(30) Priority: **13.02.2008 JP 2008032184**

(74) Representative: **Hoffmann, Eckart**  
**Bahnhofstrasse 103**  
**82166 Gräfelfing (DE)**

(71) Applicant: **Fuji Electric FA Components & Systems Co., Ltd.**  
**Chuo-ku**  
**Tokyo**  
**103-0011 (JP)**

(54) **Thermally operated overload relay**

(57) Disclosed is a thermally operated overload relay installing a linked assembly in an outer casing (1), the assembly comprising a main bimetal (2) that bends receiving heat due to electric current flowing in a main circuit, a shifter (3) that displaces responsively to the bend of the main bimetal (2), a release lever (5) that links to the shifter and opposes a reversing spring (7) for driving a contact switching mechanism (6), and an adjusting dial that positions the release lever corresponding to setting of a trigger current value; output contacts of the contact switching mechanism being switched upon detecting the bend of the main bimetal (2) due to development of an overcurrent. The adjusting dial composed of a slider (14) and is directly coupled to the release lever (5) to form a monolithic structure, and the slider (14) is operated to position the release lever (5) corresponding to setting of the trigger current value and fastened by a fastening screw (15).

**FIG. 1**

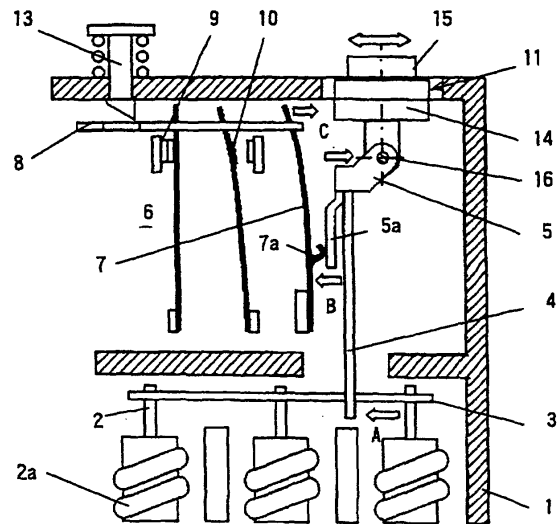

**EP 2 091 060 A2**

## Description

**[0001]** The present invention relates to a thermally operated overload relay (also referred to as a thermal relay) used in combination with an electromagnetic contactor, a molded case circuit breaker, or the like. In particular, the present invention relates to a linkage structure between a release lever for driving a reversing spring of a contact switching mechanism and an adjusting dial for setting a rated or trigger current value, i.e., a current value at which the overload relay is to be thermally operated (triggered).

**[0002]** Fig. 9 shows a typical conventional structure of a thermally operated overload relay (see for example, JP 2005-116370 A, in particular Fig. 4 thereof). In Fig. 9, the reference numeral 1 represents an outer casing made of a molded resin; the reference numeral 2 represents main bimetals, one for each phase of a three phase main circuit; the numeral 2a represents a heater; the numeral 3 represents a shifter linked to a free end of each of the main bimetals 2; the numeral 4 represents a compensation bimetal (for compensating the ambient temperature) connected to the release lever 5 at an upper end thereof and opposing the shifter 3, the compensation bimetal simultaneously serving as an input lever; and the numeral 6 represents a contact switching mechanism that performs a switching operation triggered by an output (a movement) of the release lever 5. This contact switching mechanism 6 is an assembled structure comprising a reversing spring 7 that performs a snap action by a pushing operation on the release lever 5, a slider 8 connected to an end of the reversing spring 7, and output contacts 9 (b-contact) and 10 (a-contact) that act in response to a movement of the slider 8. The reference numeral 11 represents an adjusting dial for setting a trigger current value; the numeral 12 represents an adjusting link for linking a cam portion 11 a of the adjusting dial 11 and the release lever 5; and the numeral 13 represents a reset button for manually returning the contact switching mechanism.

**[0003]** The adjusting dial 11 is disposed on the top of the outer casing 1 with a cylindrical cam portion (a tangential eccentric cam) 11a thereof projecting down into the casing. The adjusting link 12 is a seesaw type link that extends vertically and is pivotally supported by a main shaft 1a, which is a holder of the adjusting link 12, provided on the outer casing 1 and engaged to a bearing part 12a formed at the central region of the adjusting link 12. The adjusting link 12 has a cam follower 12b at the top thereof, the cam follower 12b being in contact with the outer peripheral surface of the cam portion 11 a. At the bottom end of the adjusting link 12 is provided a movable shaft 12c on which an end of the release lever 5 is pivotally supported to couple rotatably the adjusting link 12 and the release lever 5.

**[0004]** The release lever 5 coupled to the adjusting link 12 has an output end 5a standing up from an end of the adjusting link and opposing the actuation end 7a of the

reversing spring 7. To the back surface of this output end 5a fixedly connected is the top of the compensation bimetal 4.

**[0005]** According to the above-described structure, when the main bimetals 2 bend in response to being heated by heat generated by the heater 2a caused by the electric current flowing in the main circuit, and the shifter 3 is displaced in the direction of the arrow A corresponding to the bending of the main bimetals, the bending of the main bimetals 2 is transmitted through the shifter 3 and the compensation bimetal 4 to the release lever 5. As a result, the release lever 5 rotates counterclockwise (in the direction of the arrow B) around the movable shaft 12c of the adjusting link 12, and the output end 5a pushes the actuation end 7a of the reversing spring 7. When an overcurrent exceeding the trigger current value set by the adjusting dial 11 flows in the main circuit and results in the main bimetals 2 being bent to a great extent, the reversing spring 7 pushed by the output end 5a of the release lever 5 reverses in a snap action, which in turn moves the slider 8 of the contact switching mechanism 6 in the direction of the arrow C to switch the output contacts 9 and 10. This contact output signal opens an electromagnetic contactor connected to this thermal relay and interrupts the overcurrent in the main circuit. After disconnecting the main circuit, when the main bimetals 2 restore to the original state at normal room temperature after the disconnection, safety of the distribution circuit is checked and then a reset button 13 is pushed in. As a result, the slider 8 moves to the left (the direction opposite to the arrow C) to return the contacts 9 and 10, and forces to reverse the reversing spring 7 to the original state, thus, resetting the thermal relay.

**[0006]** When the adjusting dial 11 is turned to change the set trigger current value, the adjusting link 12, which links to the cam portion 11 a of the adjusting dial 11, moves the movable shaft 12c at the lower end of the adjusting link in the left or right direction (horizontal direction) around the main shaft 1 a. In response to this movement, the relative position of the output end 5a of the release lever 5 and the actuation end 7a of the reversing spring 7 are displaced to change the operation point of the thermal relay. The above-described operation procedure is well known in the art.

**[0007]** The conventional example of Fig. 9 uses the adjusting link 12 of a seesaw type. Another thermal relay is also known (e.g. JP S53-095168 U, in particular Fig. 1 thereof) that uses a structure having an adjusting lever different from the one in the example of Fig. 9. In that structure, the adjusting lever is pivotally supported on an outer casing at the lower end of the lever; the upper end of the lever is made in contact with a cam portion of an adjusting dial; and a release lever is coupled to the middle region of the adjusting lever.

**[0008]** In the conventional thermally operated overload relay described above, the cam portion 11a of the adjusting dial 11 for setting a trigger current value and the release lever 5 are linked by another separate compo-

nent, that is, the adjusting link 12, to determine the operation point of the release lever 5 corresponding to the trigger current set by the adjusting dial 11.

**[0009]** Accordingly, the outer casing 1 must assure a space for placing the adjusting link 12 and be provided with a main shaft 1a for pivotally supporting the adjusting link 12 on the outer casing 1. The conventional structure further needs a cam follower 12b and an adjusting mechanism therefor for linking the adjusting link 12 to the cam portion 11a of the adjusting dial 11. Thus, an assembly structure of a thermal relay is complicated and large sized.

**[0010]** If an operation environment of a thermal relay causes wear and back-lash in pivotally supporting parts of the adjusting link 12, the output end 5a of the release lever 5 coupled to the movable shaft 12c is also displaced from a predetermined position to a position shifted relative to the reversing spring 7. As a result, a change in the operation characteristic occurs in the thermally operated overload relay, specifically, shifting the switching operation point of the output contacts corresponding to the trigger current set by the adjusting dial 11.

**[0011]** The present invention has been made in view of the problems described above and an object of the invention is to provide a thermally operated overload relay that alleviates ill effects on operational characteristics caused by an operation environment of the thermal relay and allows reduction in the number of parts and space saving in an outer casing, by improving the linkage construction between an adjusting dial and a release lever.

**[0012]** This object is achieved by a thermally operated overload relay as claimed in claim 1. Preferred embodiments of the invention are defined in the dependent claims.

**[0013]** The following effects are obtained by the above-described construction of the invention.

(1) In the construction of the invention, the adjusting link used in the conventional construction is omitted; a release lever is directly coupled to an adjusting dial; and the positioning of the release lever is performed directly from the adjusting dial. This construction reduces the number of components and saves space in the outer casing as compared with the conventional construction. Furthermore, elimination of an adjusting lever pivotally supported and held on the outer casing avoids ill effects on operation performances caused by a displacement of the adjusting link due to a deformation of the outer casing, thus enhancing the reliability of the product.

(2) In the construction of the invention, an adjusting dial is composed of a slider or a disk and is fastened to the outer casing via a fastening screw of a notched latch mechanism to position and hold the release lever. This construction allows setting and changing of the trigger current value to be easily carried out by a manual operation and prevents the adjusting

dial from displacement apart from the set position.

**[0014]** When the adjusting dial is composed of a slider that is guided and supported along a slide groove formed in the outer casing corresponding to the operation direction of the release lever, the release lever is advantageously positioned with high accuracy corresponding to the setting operation for the trigger current value conducted by the adjusting dial.

**[0015]** Preferred embodiments of the invention will be described in detail below with reference to the drawings, in which:

Fig. 1 shows an assembly structure of a thermally operated overload relay of an Embodiment 1 of the invention;

Fig. 2 is a perspective view of an assembly structure of the adjusting dial and the release lever shown in Fig. 1;

Figs 3(a) and 3(b) show the assembly structure of Fig. 2, in which Fig 3(a) is an exploded perspective view and Fig. 3(b) is a vertical sectional view of the structure fastened to an outer casing;

Figs. 4(a) and 4(b) illustrate an assembly structure of a variation from the structure of Figs. 3(a) and 3(b), in which Fig. 4(a) is an exploded perspective view and Fig. 4(b) is a vertical sectional view;

Figs. 5(a) and 5(b) show a structure of an adjusting dial in an Embodiment 2 of the invention, in which Fig. 5(a) is a perspective view of the structure mounted on an outer casing and Fig. 5(b) is an exploded perspective view showing a notched latch mechanism shown in Fig. 5(a);

Figs. 6(a) and 6(b) show an assembly structure of an adjusting dial in an Embodiment 3 of the invention, in which Fig. 6(a) is an exploded perspective view and Fig. 6(b) is a vertical sectional view of an assembled structure;

Fig. 7 is a vertical sectional view of an assembly structure of a variation from the structure of Figs. 6(a) and 6(b);

Fig. 8 is a perspective view of an assembly structure of an adjusting dial in an Embodiment 4 of the invention; and

Fig. 9 shows a structure of a conventional example of a thermally operated overload relay.

**[0016]** Fig. 1 illustrates the construction and operation of an essential part in an Embodiment 1 according to the invention; Fig. 2 show an external view of an assembly structure linking the adjusting dial and the release lever shown in Fig. 1, and Figs. 3 through 8 shows various embodiments of configurations of the adjusting dial and constructions for fastening the adjusting dial to the outer casing. In the drawings for the embodiments, members corresponding to those in Fig. 9 are given the same symbols and are not described again.

#### Embodiment 1

**[0017]** Fig. 1 shows an assembly structure of an essential part of a thermally operated overload relay that corresponds to claims 1, 2, and 4 of the invention; Fig. 2 is a perspective view of an assembled structure linking the adjusting dial and the release lever shown in Fig. 1; and Figs. 3(a) and 3(b) show a structure for fastening the adjusting dial in any of multiple positions depending on a trigger current value to be set.

**[0018]** Referring to Fig. 1, components in a thermally operated overload relay, including main bimetals 2, a shifter 3, a compensation bimetal 4, a release lever 5, a contact switching mechanism 6 containing a reversing spring 7, and an adjusting dial 11, are all arranged in an outer casing 1, in a way similar to the arrangement in the conventional thermal relay shown in Fig. 9. However, a linkage structure between the release lever 5 and the adjusting dial 11 differs and has the following construction.

**[0019]** In the embodiment shown in the Figures, the adjusting link 12 used in the conventional structure of Fig. 9 is omitted, and an end of the release lever 5 is directly coupled to the adjusting dial 11. The adjusting dial 11 is composed of a slider 14, a top of which is inserted in a slide groove 1 b formed in the outer casing 1 to movably guide and support the slider. The release lever 5 is coupled to the lower end of the slider via a movable shaft 16. The slide groove 1b is formed in parallel to the moving direction of the release lever 5. The movable shaft 16 can be formed monolithically with the slider 14, which is preferably made of a molded resin.

**[0020]** A fastening screw (a face screw) 15, simultaneously serving as a handle for adjusting the slider 14, is provided by screwing into a projecting step portion 14a formed at the top of the slider 14. As shown in Figs. 3(a) and 3(b), the fastening screw 15 screwed from the outside of the outer casing 1 to the slider 14 is fastened to the outer casing 1 at a desired position of the slider 14 that corresponds to the desired trigger current value. The fastening screw 15 has a head with a diameter larger than the width of the slide groove 1b to fasten the slider 14 at the outer casing 1 by the fastening screw 15.

**[0021]** To set a trigger current value of the thermal relay or to change it, with the assembly structure of the adjusting dial 11 as described above, the slider 14 with the fastening screw in an unfastened state is slid to a desired

trigger current position referring to a scale on the adjusting dial, and is then fixed at this position by fastening the fastening screw 15. Thus, the release lever 5 coupled to the slider 14 is positioned and held at the position corresponding to the set trigger current value.

**[0022]** A variation from the structure of Figs. 3(a) and 3(b) for fastening the slider 14 is shown in Figs. 4(a) and 4(b). The outer casing 1 is shown in Fig. 4(a) as cut out along the slide groove 1b for easy understanding of the fastening structure of the slider 14. In this embodiment, the cross-section of the top of the slider 14 is like the letter H and is engaged with the edges of slide groove 1b formed in the outer casing 1. The tip of the fastening screw 15 that is screwed into the top 14a of the slider is pushed against the surface of the plate of outer casing 1 to fix the slider 14 at a desired position. The slide groove 1b has an insertion groove region 1b-1 formed at a longitudinal end portion of the groove. The insertion groove region 1b-1 has a greater width than the remaining portion of the groove so that the top 14a of the slider 14 may be inserted to a level where the top 14a with its cross-section shaped like the letter H it can be made to engage the slide groove 1b of the outer casing 1.

#### Embodiment 2

**[0023]** Figs. 5(a) and 5(b) show another variation from Embodiment 1 corresponding to claim 5 of the invention. This Embodiment 2 is provided with a notched latch mechanism in place of the fastening screw 15 in Embodiment 1, thereby fixing the slider 14 of the adjusting dial 11 at a desired position to set a trigger current value.

**[0024]** In this embodiment of Figs. 5(a) and 5(b), the slider 14 has a top 14a with a cross-section of the letter H as in the embodiment of Figs. 4(a) and 4(b), and the top 14a engages the slide groove 1b in the outer casing 1 and is thus slidably guided and supported. The slide groove 1b has a notched teeth row 1c with a serrated surface formed along the longitudinal direction; an engaging spring (latch spring) 17 with a configuration of the letter V composed of a leaf spring is attached to the slider 14 so as to oppose the notched teeth row 1c. The projecting tip of the engaging spring 17 is fitted into a dent of the notched teeth row 1c to position and hold the adjusting dial 11 at a selected position corresponding to the desired trigger current value. In Fig. 5(a), the reference numeral 14c represents a handle formed on the top of the slider 14. The structure of this embodiment allows adjusting the adjusting dial 11 by sliding the handle 14c without using a fastening screw.

#### Embodiment 3

**[0025]** Figs. 6(a), 6(b) and 7 show an Embodiment 3 corresponding to claims 3 and 6 of the invention. In this embodiment, the adjusting dial 11 is composed of a disk 18 that is pivotally supported by the outer casing 1 and arranged in a manner that allows rotational operation

from outside of the outer casing. The release lever 5 is coupled to the disk 18 to position the disk and set a trigger current value.

**[0026]** In the outer casing 1, are formed a window 1d (a square hole) with a shape of a slit at a place for attaching the adjusting dial, and a bearing portion 1e in the central location of the window 1d and interleaving the window 1d. The disk 18 is inserted into the window 1d and a fastening screw 19 serving simultaneously as a support shaft is screwed into the bearing portion 1e and put through a center hole 18a of the disk 18 to rotatably support the disk. The release lever 5 is coupled to a movable shaft 16 formed at a peripheral lower portion (inside the outer casing 1) of the disk 18.

**[0027]** The fastening screw 19 simultaneously serving as a support shaft has a large diameter shaft portion 19a and a small diameter shaft portion 19b formed along the axis thereof. In the structure of Figs. 6(a) and 6(b), a male screw is cut on the large diameter shaft portion 19a; a female screw is formed on the internal circumferential surface of the bearing portion 1e of the outer casing 1, the male screw being screwed into the female screw. The small diameter shaft portion 19b is put through the center hole 18a of the disk 18 to pivotally support the disk 18. When the fastening screw 19 is fastened in this structure, the end face of the large diameter shaft portion 19a pushes the disk 18 to fix the adjusting dial at this position as shown in Fig. 6(b). In the structure of Fig. 7, on the other hand, a male screw is formed on the small diameter shaft portion 19b of the fastening screw 19 and is screwed into a screw hole formed in the bearing portion 1e to fasten and fix the disk 18 of the adjusting dial.

**[0028]** To set or change a trigger current value in the above-described assembly structure, in an unfastened state of the fastening screw 19 simultaneously serving as a support shaft, the disk 18 is rotated to a desired trigger current position referring to a scale on the adjusting dial, and is then fixed at this position by fastening the screw 19. Thus, the release lever 5 coupled to the disk 18 is positioned and held at the position corresponding to the trigger current value.

#### Embodiment 4

**[0029]** Fig. 8 shows a variation from Embodiment 3, which is an Embodiment 4 corresponding to claim 7 of the invention. This embodiment uses a notched latch mechanism as a means for fastening the disk 18, in place of a fastening screw to fix the disk 18 of the adjusting dial at a trigger current position.

**[0030]** The disk 18 is pivotally supported on the bearing portion 1e of the outer casing 1 via a support shaft 20. The disk 18 has a notched teeth row 18c (actually a notched teeth ring here) with a serrated configuration formed on one end surface of the disk 18 (the upper end surface as viewed in the Fig. 8) along the circumferential direction. Opposing the notched teeth row 18c, an engaging spring 21 (latch spring) made of a leaf spring is

provided on the outer casing 1, and the tip of the engaging spring 21 is engaged with a dent of the notched teeth row 18c to position and latch the disk 18 of the adjusting dial at a desired trigger current position.

**[0031]** This construction allows an adjusting operation of the adjusting dial without fastening means to be separately operated. Instead, fixing or latching the adjusting dial is achieved by means of the engaging spring as in the Embodiment 2 (shown in Figs. 5(a) and 5(b)).

#### Claims

1. A thermally operated overload relay comprising:

an outer casing (1);  
 a linked assembly in the outer casing (1), the assembly comprising a main bimetal (2) adapted to bend in response to being heated by heat that is caused by electric current flowing in a main circuit,  
 a contact switching mechanism (6) having a reversing spring (7) for driving the contact switching mechanism (6) and output contacts (9, 10) adapted to be switched in response to the main bimetal (2) being bent due to the heat resulting from an overcurrent in said main circuit,  
 a shifter (3) arranged to be displaced in response to a bending of the main bimetal (2),  
 a release lever (5) linked to the shifter (3) and arranged opposite the reversing spring (7) for driving the contact switching mechanism (6), and  
 an adjusting dial (11; 18) arranged to position the release lever (5) corresponding to setting of a trigger current value, and  
 fastening means (15; 1c, 17; 19; 18c, 21) for fixing the adjusting dial (11; 18) to the outer casing (1) in any of plural positions each position corresponding to the setting of a respective trigger current value,

wherein the adjusting dial (11; 18) is directly coupled to the release lever (5).

2. The relay according to claim 1, wherein the adjusting dial (14) is composed of a slider that has a top (14a) thereof guided and supported slidably along a slide groove (1b) formed in the outer casing (1), said fastening means (15; 1c, 17) being adapted to fix the slider at any of plural positions along said slide groove (1 b).

3. The thermally operated overload relay according to claim 1, wherein the adjusting dial (18) is composed of a disk that is pivotally supported on a support shaft (19a, 19b, 20) with a portion of a peripheral region thereof projecting out of the outer casing (1), said

fastening means (19; 18c, 21) being adapted to fix the disk at any of plural angular positions around the support shaft.

4. The relay according to claim 2, wherein the fastening means (15) for the slider is a fastening screw that is screwed into the top (14a) of the slider and engageable with the outer casing (1). 5
  
5. The thermally operated overload relay according to claim 2, wherein the fastening means (1c, 17) for the slider is a notched latch mechanism composed of a combination of a teeth row (1c) with a configuration of serration formed along one of the slide groove (1b) in the outer casing (1) and the slider and an engaging spring (17) engageable with the teeth row (1c) and attached to the other of the slide groove (1 b) in the outer casing (1) and the slider. 10  
15
  
6. The relay according to claim 3, wherein the fastening means (19) for the disk is a fastening screw simultaneously serving as said support shaft, the fastening screw being positioned at a center of the disk and screwed into the outer casing (1) or the disk to fix the disk at the outer casing (1). 20  
25
  
7. The relay according to claim 3, wherein the fastening means (18c, 21) for the disk is a notched latch mechanism composed of a combination of a teeth row (18c) with a configuration of serration formed on one of a surface of the disk along a rotary direction and the outer casing (1), and an engaging spring (21) engageable with the teeth row (18c) and attached to the other of said surface of the disk and the outer casing (1). 30  
35

40

45

50

55

FIG. 1

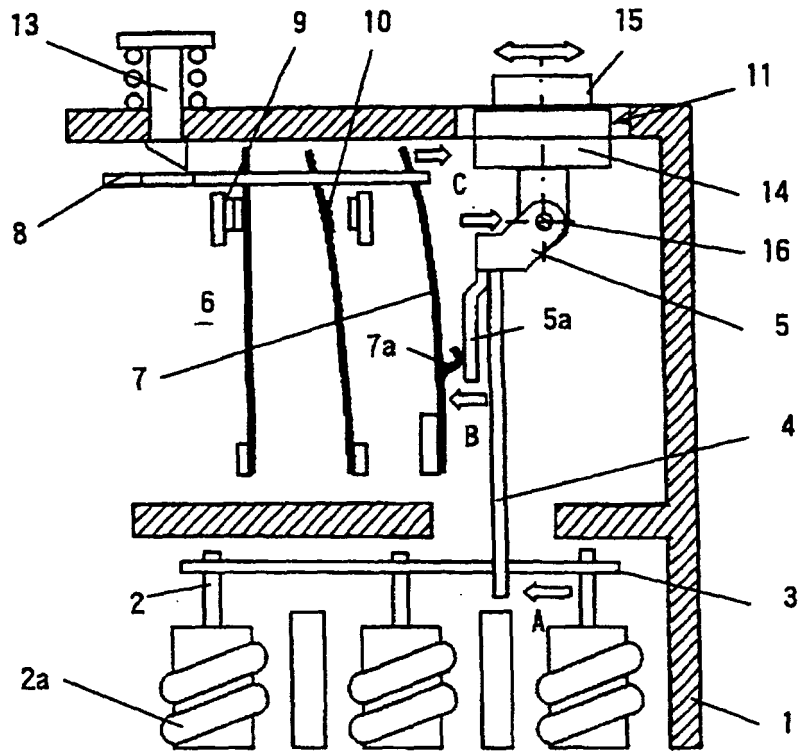

FIG. 2

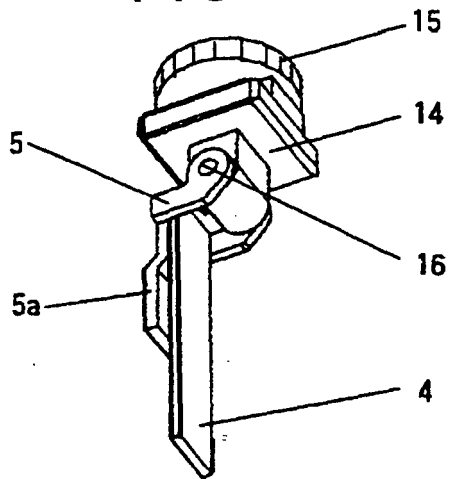
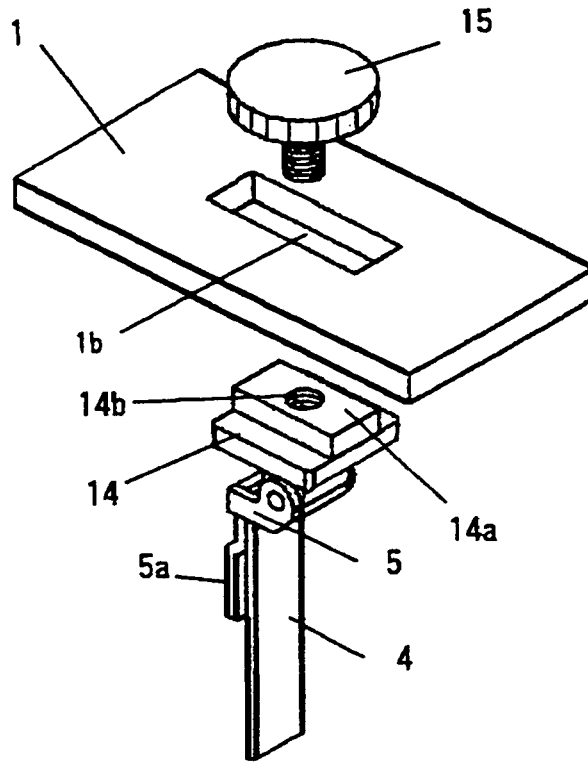
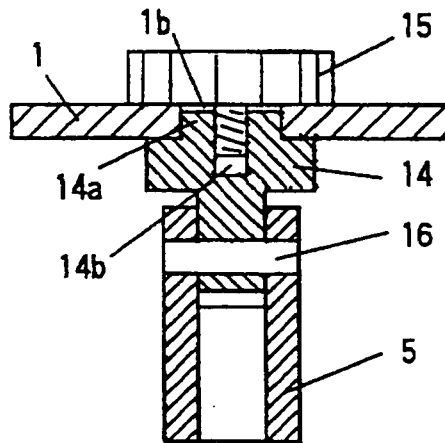

FIG. 3



(a)



(b)

FIG. 4

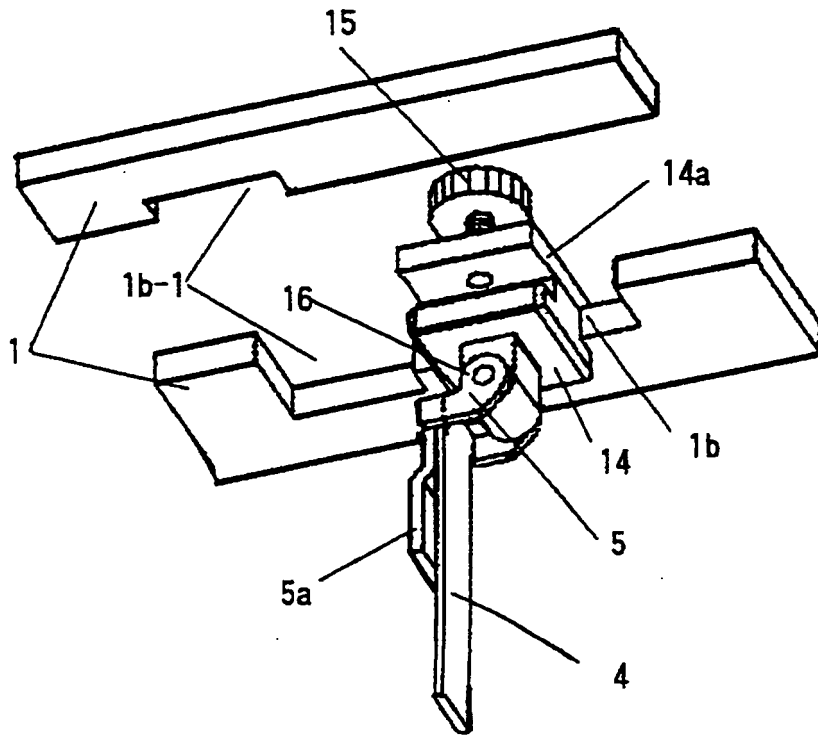

(a)

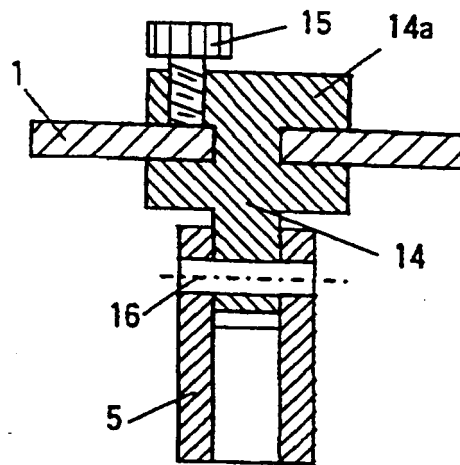

(b)

FIG. 5

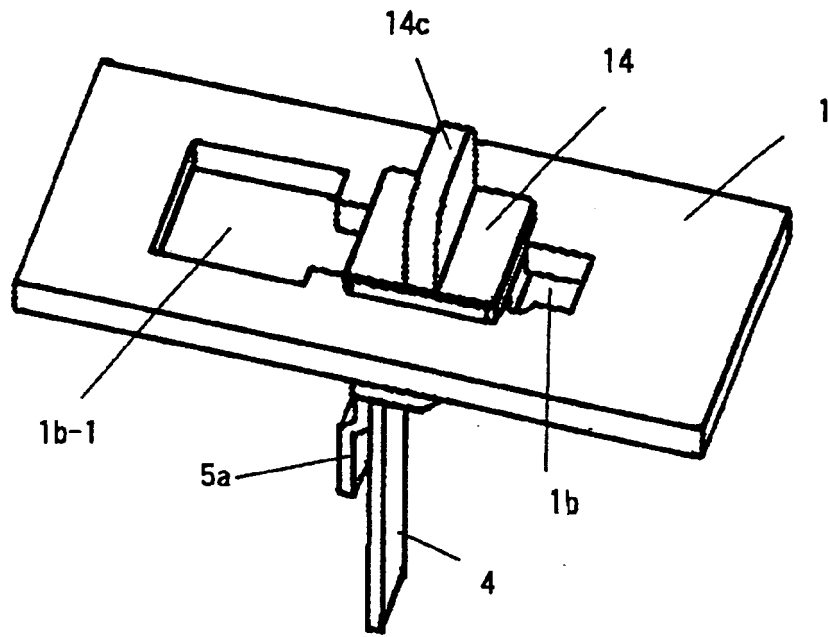

(a)

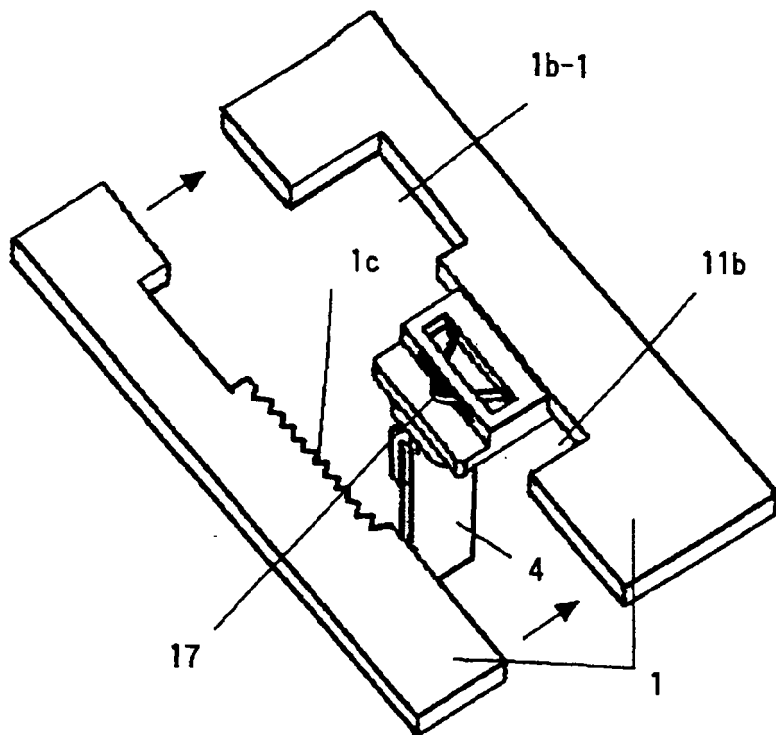

(b)

FIG. 6

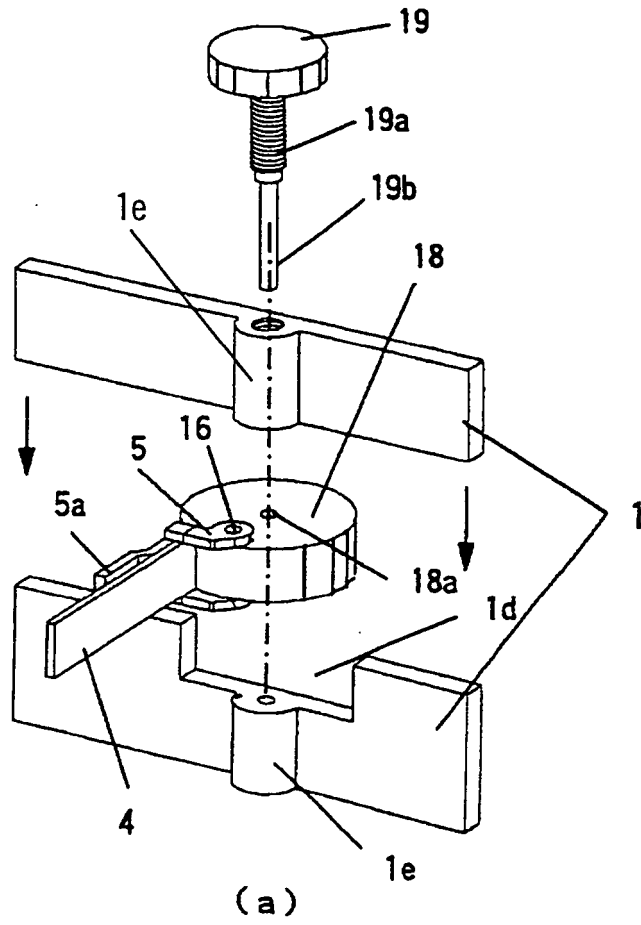

(a)

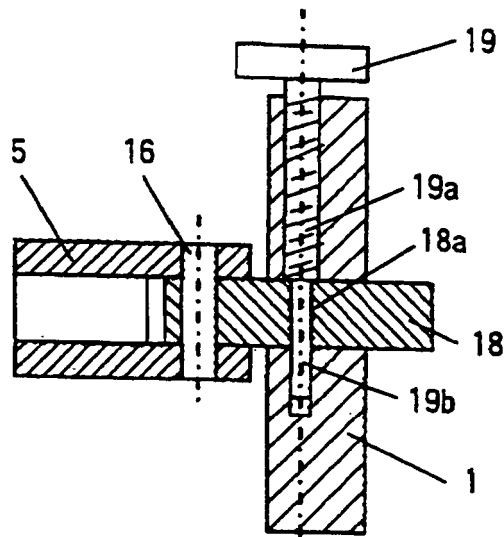

(b)

FIG. 7

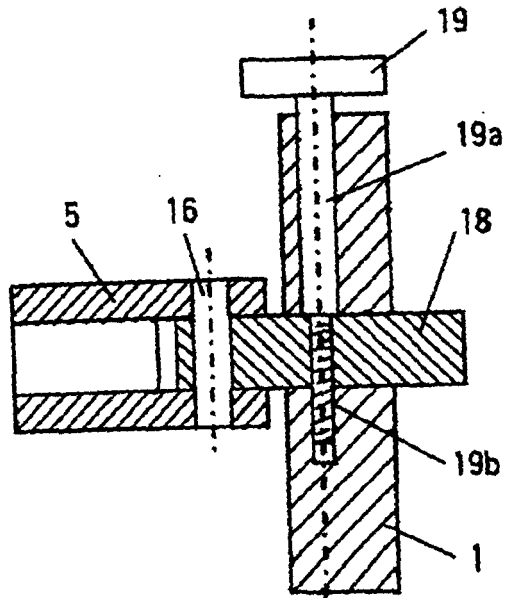
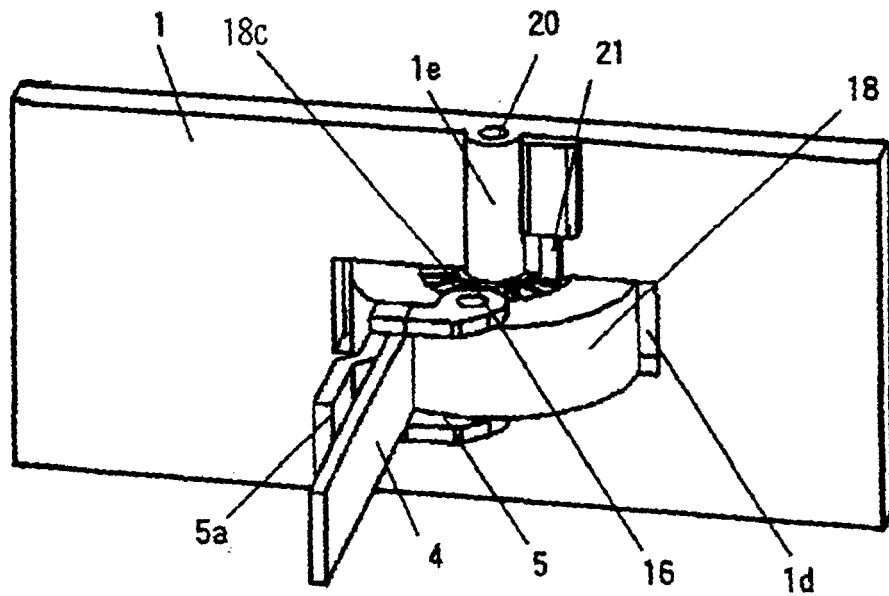

FIG. 8





**REFERENCES CITED IN THE DESCRIPTION**

*This list of references cited by the applicant is for the reader's convenience only. It does not form part of the European patent document. Even though great care has been taken in compiling the references, errors or omissions cannot be excluded and the EPO disclaims all liability in this regard.*

**Patent documents cited in the description**

- JP 2005116370 A [0002]
- JP S53095168 U [0007]