



⑫ **EUROPEAN PATENT SPECIFICATION**

④⑤ Date of publication of patent specification :  
**20.01.93 Bulletin 93/03**

⑤① Int. Cl.<sup>5</sup> : **F02M 45/08**

②① Application number : **89113992.5**

②② Date of filing : **28.07.89**

⑤④ **Fuel injector.**

③⑩ Priority : **30.07.88 JP 190783/88**

⑦③ Proprietor : **NISSAN MOTOR CO., LTD.**  
**2 Takara-cho, Kanagawa-ku**  
**Yokohama-shi Kanagawa-ken 221 (JP)**

④③ Date of publication of application :  
**07.02.90 Bulletin 90/06**

⑦② Inventor : **Ota, Ken**  
**3-68, Oppamahigashi-cho**  
**Yokosuka City (JP)**

④⑤ Publication of the grant of the patent :  
**20.01.93 Bulletin 93/03**

⑦④ Representative : **TER MEER - MÜLLER -**  
**STEINMEISTER & PARTNER**  
**Mauerkircherstrasse 45**  
**W-8000 München 80 (DE)**

⑧④ Designated Contracting States :  
**DE GB**

⑤⑥ References cited :  
**EP-A- 0 280 401**  
**DE-C- 581 476**  
**FR-A- 2 050 592**  
**FR-A- 2 333 973**  
**GB-A- 2 215 397**

**EP 0 353 657 B1**

Note : Within nine months from the publication of the mention of the grant of the European patent, any person may give notice to the European Patent Office of opposition to the European patent granted. Notice of opposition shall be filed in a written reasoned statement. It shall not be deemed to have been filed until the opposition fee has been paid (Art. 99(1) European patent convention).

## Description

The present invention relates to a fuel injector for an internal combustion engine as for example a diesel engine, according to the preamble of claim 1.

The FR-A 2 333 973 discloses a fuel injector of this kind, comprising

a nozzle body having an injection orifice at an end portion and an inner circumferential surface at the other end portion,

a generally cylindrical sleeve installed in said nozzle body for sliding movement on said inner circumferential surface,

a needle valve movably installed in said sleeve for controlling supply of pressurized fluid to said injection orifice, said needle valve having a pressure receiving surface which is subjected to fuel pressure for urging said needle valve in one direction,

said sleeve having a pressure receiving surface which is subjected to fuel pressure for urging said sleeve in said one direction,

spring means for urging said needle valve in the opposite direction,

first abutment means for limiting movement of said sleeve relative to said nozzle body to a first movable range,

second abutment means for limiting movement of said needle valve relative to said nozzle body to a second movable range which is larger than the first movable range,

engagement means for engaging said needle valve and said sleeve with each other and thereby allowing same to move together at the time of movement of said sleeve within the first movable range,

said engagement means comprising a flange portion provided to an end of that needle valve and arranged outside of that sleeve, and an end portion of said sleeve abuttingly engageable with said flange portion, and

a distance piece being arranged at the end portion of the sleeve.

A fuel injector is opened automatically by means of fuel pressure supplied thereto from a fuel injection pump. In this connection, when fuel pressure exceeds a predetermined valve opening pressure, a needle valve is raised to its maximumly lifted position momentarily, whereby to effect a relatively sudden or abrupt fuel injection. This causes a problem that the fuel injection rate (the amount of injected fuel per a unit time or a unit crank angle) at the initial stage of fuel injection becomes excessively high and causes an increased engine noise.

In order to solve this problem, it has recently been proposed a fuel injector which is adapted to effect stepwise variations of lift in response to two different valve opening pressures. Fig. 5 shows this kind of fuel injector.

In Fig. 5, movably installed in a nozzle body 31 is

a needle valve 32 which is urged in a valve closing direction by a first spring 34 and by way of a first push rod 33. The rear end of the first push rod 33 is arranged in opposition to the front end of a second push rod 35. The second push rod 35 is urged toward the first push rod 33 by a second spring 36. A clearance corresponding to a predetermined pre-lift "I" is provided between the rear end of the first push rod 33 and the front end of the second push rod 35. Though not shown, a distance piece is provided for determining a maximum lift "L" of the needle valve 32.

With the above structure, the needle valve 32 starts lifting when fuel pressure exceeds the valve opening pressure determined by the first spring 34. The needle valve 32 stops lifting once when the first push rod 33 abuts upon the second push rod 35. When fuel pressure increases further and exceeds the valve opening pressure determined by both of the first and second spring 34, 36, the needle valve 32 starts lifting again and is moved into its maximumly lifted position.

Accordingly, the needle valve 32 effects two step variations of lift, i.e., a pre-lift "I" and a maximum lift "L". This makes it possible to prevent rapid combustion under a low speed and low to medium load condition of an engine.

The prior art fuel injector encounters a problem that it requires a number of constituent parts since it is adapted to employ two springs 34,36.

Another problem is that the valve opening pressures determined by the respective springs 34,36 need to be adjusted independently, thus resulting in a poor working efficiency.

A further problem is that a valve lift characteristic provided by two kinds of springs 34,36 is liable to become unstable.

It is an object of the invention to provide an improved fuel injector of the above described kind having a reduced number of constituent parts. It is another object of the present invention to provide an improved fuel injector of the above described character which can attain adjustment of its valve opening pressure with ease and therefore can effect an improved working efficiency. It is a further object to provide a fuel injector which can effect a stable valve lift characteristic and therefore is reliable in operation.

To comply with these objects, the fuel injector according to the invention is characterized in that the first abutment means comprises a reduced diameter portion provided at the other end portion of said sleeve for thereby forming a shoulder, a reduced diameter portion provided to an end portion of said inner circumferential surface for thereby forming a stopper upon which said shoulder abuts under bias of the spring means, and the end portion of the sleeve being spaced away from said distance piece a distance corresponding to the first movable range when said shoulder of said sleeve is abuttingly engaged with

said stopper.

Fig. 1 is a sectional view of a fuel injector according to an embodiment of the present invention;

Fig. 2 is a graph of lift as a function of fuel pressure for the fuel injector of Fig. 1;

Fig. 3 is a graph of fuel injection rate as a function of time for the fuel injector of Fig. 1;

Fig. 4 is a fragmentary sectional view of a fuel injector according to another embodiment of the present invention, and

Fig. 5 is a sectional view of a prior art fuel injector.

Referring to Fig. 1, a fuel injector according to an embodiment of the present invention includes a nozzle body 1 having at an end portion a plurality of injection orifices 2. A nozzle holder 3 is arranged in line with the nozzle body 1 and has a pressurized fuel passage 4 and a return passage 5. A distance piece 6 is interposed between the nozzle body 1 and the nozzle holder 3. The nozzle body 1 and the distance piece 6 is fastened to the nozzle holder 3 by means of a holder nut 7. The nozzle body 1 is a hollow and has an inner circumferential surface 1a at the other end portion opposite to the end portion formed with the injection orifices 2. An auxiliary sleeve 8 which is generally cylindrical is installed in the nozzle body 1 for sliding movement on the inner circumferential surface 1a of the nozzle body 1. A needle valve 9 is concentrically installed in the nozzle body 1 and partly received by the auxiliary sleeve 8 for sliding movement on an inner circumferential surface 8b of the auxiliary sleeve 8. A nozzle spring 10 is provided for urging the needle valve 9 toward the nozzle body end portion formed with the injection orifices 2, i.e., in the valve closing direction by way of a push rod 11.

The auxiliary sleeve 8 is reduced in outer diameter at an end portion nearer to the injection orifices 2 to provide a radially inwardly extending shoulder 8c while the inner circumferential surface 1a is reduced in diameter at an end portion to provide a radially inwardly extending stopper 12 upon which the shoulder 8c of the auxiliary sleeve 8 is capable of abutting and thereby preventing further movement of the auxiliary sleeve 8 toward the injection orifices 2, i.e., in the direction corresponding to that in which the needle valve 9 is moved to contact a conical or tapered seat 1b of the injector body 1 to close the fuel injector. On the other hand, a clearance " $\ell$ " is provided between the other end of the auxiliary sleeve 8 and the distance piece 6 when the shoulder 8c is in contact with the stopper 12. The auxiliary sleeve 8 is capable of abutting upon the distance piece 6 through movement over the distance " $\ell$ " and thus limited in movement toward the distance piece 6, i.e., in movement in the direction corresponding to that in which the needle valve 9 moves to open the fuel injector. By this, the reciprocative stroke of the auxiliary sleeve 8 is set so as to coincide with a predetermined pre-lift " $\ell$ ".

The auxiliary sleeve 8 has at an end nearer to the

injection orifices 2 a conical or tapered pressure receiving surface 8a constituting part of a wall defining a pressure chamber 13. The pressure chamber 13 is annular in shape and formed in the nozzle body 1 in such a way as to concentrically encircle the needle valve 9. The pressure chamber 13 is communicated with the pressurized fuel passage 4 of the nozzle holder 3 through a pressurized fuel passage 14 formed in the nozzle body 1 and adapted to be supplied with pressurized fuel from a fuel injection pump (not shown).

The needle valve 9 has a conical end 9a capable of contacting the conical seat 1b of the nozzle body 1 to obstruct communication between the pressure chamber 13 and the injection ports 2. The needle valve 9 has at an axially intermediate portion a conical or tapered pressure receiving surface 9b and at a portion next to the conical end 9a a conical or tapered pressure receiving surface 9c. The pressure receiving surface 9b is continuous with the pressure receiving surface 8a of the auxiliary sleeve 8 when the shoulder 8b is in contact with the stopper 12 and adapted to define part of the pressure chamber 13. The needle valve 9 has, at an end opposite to the conical end portion 9a, a disk-like flange portion 15 which is arranged outside of the auxiliary sleeve 8 and formed so as to have an outer diameter that is larger than the inner diameter of the auxiliary sleeve 8 and thus capable of abutting upon the corresponding end of the auxiliary sleeve 8 at the time of lifting of the auxiliary sleeve 8. The distance piece 6 is formed with a concentric circular recess 16 into which the flange portion 15 is insertable while sliding on the inner circumferential surface of same. By the abutment of the flange portion 15 upon a bottom face 16a of the recess 16, the maximum lift "L" of the needle valve 9 is determined. Under the condition in which the conical end 9a of the needle valve 9 is placed on the conical seat 1b of the nozzle body 1 while at the same time the shoulder 8c of the auxiliary sleeve 8 is in abutment upon the stopper portion 12, the auxiliary sleeve 8 and the flange portion 15 are nearly in contact with each other but strictly there exists a quite small clearance between them.

Interposed between the nozzle spring 10 and a corresponding seating surface of the nozzle holder 3 is a shim 17 for adjusting the valve opening pressure.

The operation of the fuel injector will be described hereinbelow.

When the needle valve 9 rests on the conical seat 1b of the nozzle body 1 under the bias of the nozzle spring 10, the shoulder 8c of the auxiliary sleeve 8 is brought into contact with the stopper portion 12 under the bias of the nozzle spring 10 by way of the flange portion 15. Lifting of the auxiliary sleeve 8 under this condition causes the needle valve 9 to move together therewith.

Accordingly, under this condition, all of the fuel

pressures acting on the pressure receiving surface 8a of the auxiliary sleeve 8 and the pressure receiving surfaces 9b, 9c of the needle valve 9 are effective for lifting of the needle valve 9. That is, a relatively large pressure receiving surface is obtained for driving the needle valve 9.

Due to this, when the fuel pressure acting on the pressure receiving surface exceeds "Po" as shown in Fig. 2, the needle valve 9 is lifted off the seat 1b and keeps lifting together with the auxiliary sleeve 8.

When the needle valve 9 and the auxiliary sleeve 8 performs the pre-lift " $l$ ", the auxiliary sleeve 8 abuts upon the distance piece 6. In this instance, the flange portion 15 of the needle valve 9 is out of contact with the bottom surface 16a of the recess 16 so that the needle valve 9 is solely liftable further. From this stage onward, only the pressure receiving surfaces 9b, 9c of the needle valve 9 are thus effective for driving the needle valve 9. Since a relatively smaller pressure receiving surface is obtained for driving the needle valve 9 as compared with that during the pre-lifting, the needle valve 9 stops lifting once when it is raised the pre-lift " $l$ " as shown in Fig. 2 and remains in the standstill condition when the fuel pressure ranges from P1 to P2.

When the fuel pressure increases further to cause the force acting on the pressure receiving surfaces 9a-9c of the needle valve 9 to exceed beyond the valve opening pressure given by the nozzle spring 10, the needle valve 9 solely starts lifting further and keeps on same until it raised the maximum lift "L" whereupon the flange portion 15 abuts upon the bottom surface 16a of the recess 16.

Accordingly, with the above structure, it becomes possible to attain a valve lift characteristic which effects two step variations as shown in Fig. 2 by using the single nozzle spring 10. By this, it becomes possible to obtain such a fuel injection rate characteristic as shown by the solid lines in Fig. 3, thus making it possible to restrict the quantity of injected fuel during the ignition delaying period and thereby attain moderate combustion. In the meantime, the dotted lines in Fig. 3 represents the injection rate characteristic of a comparable prior art fuel injector of the type adapted to effect a constant valve opening pressure.

From the foregoing, it will be understood that the fuel injector of the present invention can reduce the number of constituent parts and therefore the cost.

It will be further understood that adjustment of the valve opening pressure can be attained by an easy adjusting work of the single nozzle spring 10, thus making it possible to increase the working efficiency.

It will be further understood that variations in the spring performance characteristic of the nozzle spring 10 can be smaller as compared with those in case where two nozzle springs arranged in series are employed, thus making it possible to attain a stable valve lift characteristic.

It will be further understood that the pre-lift " $l$ " and the maximum lift "L" are determined by the clearance between the needle valve 9 and the distance piece 6 and the clearance between the auxiliary valve 8 and the distance piece 6, respectively, thus making it possible to control their accuracies with ease and attain their repairs before they are installed in place, and therefore making it possible to attain an improved working efficiency.

Fig. 4 shows another embodiment which is adapted to vary the fuel injecting directions, etc. by using the above described stepwisely varying lift.

In this embodiment, the nozzle body 1 has a relatively large domed end portion 21 including a cylindrical inner circumferential surface 22. The domed end portion 21 has adjacent the terminal end a single or a plurality of first injection orifices 24. The nozzle body 1 has next to the inner circumferential surface 22 a conical or tapered seat 23 on which the needle valve 9 rests. A plurality of second injection orifices 25 are formed in a conical or tapered wall portion of the nozzle body 1 defining the seat 23 and adjacent the smaller diameter end of same.

The needle valve 9 has at a terminal end a throttle pin 26 which slides on the the inner circumferential surface 22. The throttle pin 26 is of such a length that corresponds to the above described pre-lift " $l$ " when the conical end portion 9a rests on the seat 23.

With the above structure, during the time when the needle valve 9 is lifted off the seat 23 and its lift is smaller than the pre-lift " $l$ ", the throttle pin 26 keeps obstructing communicating between the inside of the domed end portion 21 and the pressure chamber 13, thus allowing fuel to be injected only through the second injection orifices 25. When the needle valve 9 is lifted further, the throttle pin 26 allows to communicate the inside of the domed end portion 21 and the pressure chamber 13, thus allowing fuel to be injected through both the first injection orifices 24 and the second injection orifices 25.

Accordingly, by variously setting the bore diameters of the orifices 24, 25 and the axial directions of same, it becomes possible to variously design the shape of the injected fuel mist with an increased freedom.

## Claims

1. A fuel injector comprising
  - a nozzle body (1) having an injection orifice (2) at an end portion and an inner circumferential surface (1a) at the other end portion,
  - a generally cylindrical sleeve (8) installed in said nozzle body for sliding movement on said inner circumferential surface (1a),
  - a needle valve (9) movably installed in said sleeve (8) for controlling supply of pressurized

fluid to said injection orifice, said needle valve (9) having a pressure receiving surface (9b) which is subjected to fuel pressure for urging said needle valve (9) in one direction,

said sleeve having a pressure receiving surface (8a) which is subjected to fuel pressure for urging said sleeve in said one direction,

spring means (10) for urging said needle valve in the opposite direction,

first abutment means (8,6) for limiting movement of said sleeve (8) relative to said nozzle body (1) to a first movable range ( $\ell$ ),

second abutment means (15,16a) for limiting movement of said needle valve (9) relative to said nozzle body (1) to a second movable range (L) which is larger than the first movable range ( $\ell$ ),

engagement means (8,15) for engaging said needle valve (9) and said sleeve (8) with each other and thereby allowing same to move together at the time of movement of said sleeve within the first movable range ( $\ell$ ),

said engagement means comprising a flange portion (15) provided to an end of that needle valve (9) and arranged outside of that sleeve (8), and an end portion of said sleeve (8) abuttingly engageable with said flange portion (15), and

a distance piece (6) being arranged at the end portion of the sleeve,

**characterized** in that

the first abutment means comprises a reduced diameter portion provided at the other end portion of said sleeve (8) for thereby forming a shoulder (8c), a reduced diameter portion provided to an end portion of said inner circumferential surface (1a) for thereby forming a stopper (12) upon which said shoulder (8c) abuts under bias of the spring means (10), and the end portion of the sleeve (8) being spaced away from said distance piece (6) a distance corresponding to the first movable range (1) when said shoulder (8c) of said sleeve (8) is abuttingly engaged with said stopper (12).

2. The fuel injector according to claim 1, **characterized** in that said second abutment means comprises a tapered seat (16) provided to said one end portion of said nozzle body (1) adjacent said injection orifice (2), a tapered end portion (9c) provided to the other end of said needle valve (9) for abutting engagement with said seat, a recess (16) formed in said distance piece (6) and having a bottom surface (16a), said flange portion (15) of said needle valve movably received in said recess and having an end face which is spaced from said bottom surface of said recess a predetermined distance corresponding to said second movable range (L) when said tapered end portion

of said needle valve is abuttingly engaged with said seat of said nozzle body (12).

3. The fuel injector according to claim 2, **characterized** in that said nozzle body (9) further comprises a pressure chamber (13) next to said inner circumferential surface for receiving therein pressurized fuel, said pressure receiving surface (8a) of said sleeve (8) being arranged so as to define part of said pressure chamber, said pressure receiving surface (9b) of said needle valve (9) including a pressure receiving surface portion provided to an axially intermediate portion of said needle valve and arranged so as to define part of said pressure chamber, said pressure receiving surface of said sleeve and said pressure receiving surface portion of said needle valve being continuous with each other when said sleeve and said needle valve are abuttingly engaged with said stopper and said seat, respectively.
4. The fuel injector according to claim 3, **characterized** in that the injector comprises a nozzle holder (3) arranged in line with said nozzle body (1), said distance piece (6) being interposed between said nozzle body and said nozzle holder, a holder nut (7) fastening said nozzle body and said distance piece to said nozzle holder.
5. The fuel injector according to claim 4, **characterized** in that said spring means (10) comprises a single spring arranged in line with said needle valve (9) and received in said nozzle holder (3).
6. The fuel injector according to claim 5, **characterized** in that said spring means (10) further comprises a push rod (11) interposed between one end of said spring and said flange portion (15) of said needle valve (9) and a shim (17) interposed between the other end of said spring and a corresponding seating face provided to said nozzle holder.
7. The fuel injector according to claim 1, **characterized** in that said nozzle body (1) has a domed end portion (21) formed with said injection orifice (21), said domed end portion having a cylindrical inner circumferential surface (22), said nozzle body further having a tapered wall portion defining a tapered seat (23) next to said cylindrical inner circumferential surface, said tapered wall portion being formed with a plurality of second injection orifices (25), said needle valve (9) having a tapered end portion abuttingly engageable with said seat for controlling supply of pressurized fuel to said second injection orifices, said needle valve having at a terminal end a cylindrical throttle pin (26) projecting from said tapered end por-

tion and slidable on said inner circumferential surface of said domed end portion for controlling supply of fuel to said first mentioned injection orifice.

## Patentansprüche

1. Kraftstoff-Einspritzvorrichtung, mit
  - einem Düsenkörper (1) mit einer Einspritzöffnung (2) an einem Endbereich und einer inneren Umfangsfläche (1a) am anderen Endbereich,
  - einer im wesentlichen zylindrischen Hülse (8) in dem Düsenkörper, die auf der inneren Umfangsfläche (1a) gleitet,
  - einem Nadelventil (9), das beweglich in der Hülse (8) angeordnet ist und die Zufuhr von Druckfluid zu der Einspritzöffnung steuert, welches Nadelventil (9) eine Druckaufnahme-  
fläche (9b) aufweist, die dem Kräftstoffdruck ausgesetzt ist und das Nadelventil in die eine Richtung drückt,
  - einer Federeinrichtung (10), die das Nadelventil in die entgegengesetzte Richtung drückt,
  - einer ersten Anschlageinrichtung (8,6) zur Begrenzung der Bewegung der Hülse (8) in bezug auf den Düsenkörper (1) auf einen ersten beweglichen Bereich ( $\ell$ ),
  - einer zweiten Anschlageinrichtung (15,16a) zur Begrenzung der Bewegung des Nadelventils (9) in bezug auf den Düsenkörper (1) auf einen zweiten beweglichen Bereich (L), der größer als der erste bewegliche Bereich ( $\ell$ ) ist,
  - einer Eingriffseinrichtung (8, 15) zum Verbinden des Nadelventils (9) und der Hülse (8) und damit zum Ermöglichen einer gemeinsamen Bewegung zur Zeit der Bewegung der Hülse innerhalb des ersten beweglichen Bereichs ( $\ell$ ),
  - welche Eingriffseinrichtung einen Flanschbereich (15) umfaßt, der an einem Ende des Nadelventils (9) außerhalb der Hülse (8) vorgesehen ist, wobei ein Endbereich der Hülse (8) mit dem Flanschbereich (15) anschlagend in Eingriff zu bringen ist, und
  - einem Distanzstück (6) an dem Endbereich der Hülse,  
dadurch **gekennzeichnet**, daß die erste An-  
schlageinrichtung einen Bereich reduzierten  
Durchmessers umfaßt, der am anderen End-  
bereich der Hülse (8) vorgesehen ist und eine  
Schulter (8c) bildet, daß ein reduzierter  
Durchmesserbereich in einem Endbereich der  
inneren Umfangsfläche (1a) vorgesehen ist  
und auf diese Weise einen Anschlag (12) bil-
2. Kraftstoff-Einspritzvorrichtung nach Anspruch 1, dadurch **gekennzeichnet**, daß die zweite An-  
schlageinrichtung einen abgeschrägten Sitz (16)  
umfaßt, der an einem Endbereich des Düsenkör-  
pers (1) angrenzend an die Einspritzöffnung (2)  
vorgesehen ist, daß ein abgeschrägter Endbe-  
reich (9c) am anderen Ende des Nadelventils (9)  
vorgesehen ist, der zum anschlagenden Zusam-  
mentreffen mit dem Sitz dient, daß eine Ausneh-  
mung (16) in dem Distanzstück (6) ausgebildet  
ist, die eine Bodenfläche (16a) aufweist, daß der  
Flanschbereich (15) des Nadelventils beweglich  
in der Ausnehmung angeordnet ist und eine End-  
fläche aufweist, die in einem Abstand von der Bo-  
denfläche der Ausnehmung liegt, der dem zwei-  
ten beweglichen Bereich (L) entspricht, wenn der  
schräge Bereich des Nadelventils anschlagend  
mit dem Sitz des Düsenkörpers (12) in Eingriff  
tritt.
3. Kraftstoff-Einspritzvorrichtung nach Anspruch 2,  
dadurch **gekennzeichnet**, daß der Düsenkörper  
(9) weiterhin eine Druckkammer (13) in der Nähe  
der inneren Umfangsfläche aufweist, die unter  
Druck stehenden Kraftstoff aufnimmt, welche  
Druck aufnehmende Fläche (8a) der Hülse (8) so  
angeordnet ist, daß sie ein Teil der Druckkammer  
bildet, daß die Druck aufnehmende Fläche (9b)  
des Nadelventils (9) einen Flächenbereich auf-  
weist, der in einem axialen Mittelbereich des Na-  
delventils angeordnet ist und einen Teil der  
Druckkammer bildet, daß die Druck aufnehmen-  
de Fläche der Hülse und der Druck aufnehmende  
Flächenbereich des Nadelventils kontinuierlich  
zueinander verlaufen, wenn die Hülse und das  
Nadelventil in anschlagendem Eingriff mit dem  
Anschlag und dem Sitz stehen.
4. Kraftstoff-Einspritzvorrichtung nach Anspruch 3,  
dadurch **gekennzeichnet**, daß die Vorrichtung  
einen Düsenhalter (3) in Reihe mit dem Düsen-  
körper (1) umfaßt, welches Distanzstück (6) zwi-  
schen den Düsenkörper und dem Düsenhalter  
liegt, und daß eine Haltemutter (7) den Düsenkör-  
per und das Distanzstück an dem Düsenhalter  
befestigt.
5. Kraftstoff-Einspritzvorrichtung nach Anspruch 4,  
dadurch **gekennzeichnet**, daß die Federeinrich-  
tung (10) eine einzelne Feder umfaßt, die in Rei-

he mit dem Nadelventil (9) angeordnet ist und in dem Düsenhalter (3) aufgenommen ist.

6. Kraftstoff-Einspritzvorrichtung nach Anspruch 5, dadurch **gekennzeichnet**, daß die Federeinrichtung (10) weiterhin eine Schubstange (11) umfaßt, die zwischen einem Ende der Feder und dem Flanschbereich (15) des Nadelventils (9) liegt, und eine Unterlegscheibe (17) zwischen dem anderen Ende der Feder und einer entsprechenden Sitzfläche an dem Düsenhalter.
7. Kraftstoff-Einspritzvorrichtung nach Anspruch 1, dadurch **gekennzeichnet**, daß der Düsenkörper (1) einen kuppelförmigen Endbereich (21) umfaßt, der mit der Einspritzöffnung (2) versehen ist, daß der kuppelförmige Endbereich eine zylindrische innere Umfangsfläche (22) aufweist, daß der Düsenkörper weiterhin einen abgeschrägten Wandbereich aufweist, der einen abgeschrägten Sitz (23) angrenzend an die zylindrische innere Umfangsfläche bildet, daß der abgeschrägte Wandbereich mit einer Anzahl von zweiten Einspritzöffnungen (25) versehen ist, daß das Nadelventil (9) einen abgeschrägten Endbereich aufweist, der anschlagend mit dem Sitz in Eingriff tritt und die Zufuhr von unter Druck stehendem Kraftstoff zu den zweiten Einspritzöffnungen steuert, und daß das Nadelventil an einem Ende einen zylindrischen Drosselstift (26) aufweist, der von dem abgeschrägten Endbereich vorspringt und gleitend auf der inneren Umfangsfläche des kuppelförmigen Endbereichs zur Steuerung der Zufuhr von Kraftstoff zu der ersten Einspritzöffnung beweglich ist.

## Revendications

1. Injecteur de combustible comprenant un corps de gicleur ou de buse (1) présentant un orifice d'injection (2) à une portion extrême et une surface circonférentielle interne (1a) à l'autre portion extrême, un manchon généralement cylindrique (8) installé dans ledit corps de gicleur en vue d'un mouvement coulissant sur ladite surface circonférentielle interne (1a), une soupape à pointe (9) installée mobile dans ledit manchon (8) pour contrôler l'amenée de fluide sous pression audit orifice d'injection, ladite soupape à pointe (9) présentant une surface de réception de pression (9b) qui est sujette à la pression du combustible pour solliciter ladite soupape à pointe (9) dans une direction, ledit manchon possédant une surface de réception de pression (8a) qui est sujette à la pression du combustible pour solliciter ledit manchon dans ladite une direction, des moyens de ressort (10) pour solliciter ladite soupape à pointe dans la direction opposée, des premiers moyens de butée (8, 6) pour limiter le mouvement dudit manchon (8) relativement audit corps de gicleur (1) à une première plage mobile (ℓ), des deuxièmes moyens de butée (15, 16a) pour limiter le mouvement de ladite soupape à pointe (9) relativement audit corps de gicleur (1) à une deuxième plage mobile (L) qui est plus grande que la première plage mobile (ℓ), des moyens d'engagement (8, 15) pour la venue en prise de ladite soupape à pointe (9) et dudit manchon (8), l'un avec l'autre et en permettant ainsi à ceux-ci de se déplacer ensemble à l'instant du déplacement dudit manchon à l'intérieur de la première plage mobile (ℓ), lesdits moyens d'engagement comprenant une portion de rebord ou d'épaulement (15) réalisée à une extrémité de cette soupape à pointe (9) et disposée à l'extérieur de ce manchon (8), et une portion extrême dudit manchon (8) pouvant venir en prise de butée avec ladite portion de rebord (15), et une pièce d'écartement (6) étant disposée à la portion extrême du manchon, caractérisé en ce que le premier moyen de butée comprend une portion à diamètre réduit réalisé à l'autre portion extrême dudit manchon (8) pour former ainsi un épaulement (8c), une portion à diamètre réduit réalisé à une portion extrême de ladite surface circonférentielle interne (1a) pour former ainsi un élément d'arrêt ou butoir (12) contre lequel bute ledit épaulement (8c) lorsqu'il est sollicité par le moyen de ressort (10), et la portion extrême du manchon (8) étant espacée par rapport à ladite pièce d'espacement (6) d'une distance correspondant à la première plage mobile (ℓ) lorsque ledit épaulement (8c) dudit manchon (8) est en prise de butée avec ledit élément d'arrêt ou butoir (12).
2. Injecteur de combustible selon la revendication (1), caractérisé en ce que ledit deuxième moyen de butée comprend un siège conique (16) réalisé dans ladite portion extrême dudit corps de gicleur (1) adjacente audit orifice d'injection (2), une portion extrême conique (9c) réalisée à l'autre extrémité de ladite soupape à pointe (9) en vue d'une prise de butée avec ledit siège, un évidement (16) pratiqué dans ladite pièce d'espacement (6) et présentant une surface de fond (16a), ladite portion de rebord (15) de ladite soupape à pointe étant reçue de façon mobile dans ledit évidement et présentant une face extrême qui est

- espacée par rapport à ladite surface de fond dudit évidemment d'une distance prédéterminée correspondant à ladite deuxième plage mobile (L), lorsque ladite portion extrême conique de ladite soupape à pointeau est en prise de butée avec ledit siège dudit corps de gicleur (12). 5
3. Injecteur de combustible selon la revendication 2, caractérisé en ce que ledit corps de gicleur (9) comprend, en outre, une chambre de pression (13) contiguë à ladite surface circonférentielle interne pour recevoir à l'intérieur du combustible sous pression, ladite surface de réception de pression (8a) dudit manchon (8) étant disposée de façon à définir une partie de ladite chambre de pression, ladite surface de réception de pression (9b) de ladite soupape à pointeau (9) comprenant une portion de surface de réception de pression réalisée sur une portion axialement intermédiaire de ladite soupape à pointeau et disposée de façon à définir une partie de ladite chambre de pression, ladite surface de réception de pression dudit manchon et ladite portion de surface de réception de pression de ladite soupape à pointeau étant continues l'une avec l'autre lorsque ledit manchon et ladite soupape à pointeau sont en prise de butée avec ledit élément d'arrêt et ledit siège, respectivement. 10 15 20 25
4. Injecteur de combustible selon la revendication 3, caractérisé en ce que l'injecteur comprend un support de gicleur (3) disposé en ligne avec ledit corps de gicleur (1) ladite pièce d'espacement (6) étant interposée entre ledit corps de gicleur et ledit support de gicleur, un écrou de support (7) fixant ledit corps de gicleur et ladite pièce d'espacement audit support de gicleur. 30 35
5. Injecteur de combustible selon la revendication 4, caractérisé en ce que ledit moyen de ressort (10) comprend un seul ressort disposé en ligne avec ladite soupape à pointeau (9) et reçu dans ledit support de gicleur (3). 40
6. Injecteur de combustible selon la revendication 5, caractérisé en ce que ledit moyen de ressort (10) comprend, en outre, une tige poussoir (11) interposée entre une extrémité dudit ressort et ladite portion de rebord (15) de ladite soupape à pointeau (9) et une rondelle de calage (17) interposée entre l'autre extrémité dudit ressort et une face correspondante formant siège réalisée dans ledit support de gicleur. 45 50
7. Injecteur de combustible selon la revendication 1, caractérisé en ce que ledit corps de gicleur (1) présente une portion extrême bombée (21) réalisée dans ledit orifice d'injection (21), ladite por- 55
- tion extrême bombée présentant une surface circonférentielle interne cylindrique (22), ledit corps de gicleur présentant, en outre, une portion de paroi conique définissant un siège conique (23) contigu à ladite surface circonférentielle interne cylindrique, ladite portion de paroi conique présentant une pluralité de deuxième orifices d'injection (25), ladite soupape à pointeau (9) présentant une portion extrême conique pouvant venir en prise de butée avec ledit siège pour contrôler l'amenée du combustible sous pression auxdits deuxième orifices d'injection, ladite soupape à pointeau présentant à une extrémité terminale une broche d'étranglement cylindrique (26) faisant saillie à partir de ladite portion extrême conique et pouvant coulisser sur ladite surface circonférentielle interne de ladite portion extrême bombée pour contrôler ou commander l'amenée de combustible audit orifice d'injection mentionné en premier.

**FIG.1**

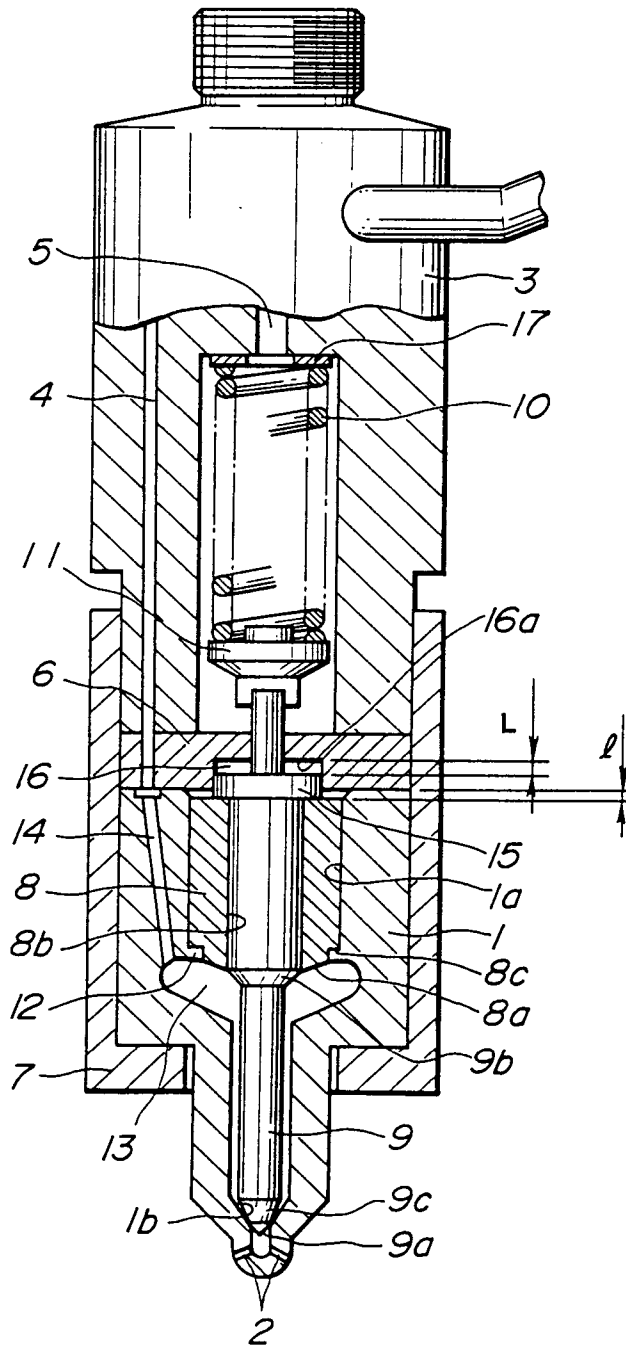

**FIG. 2**

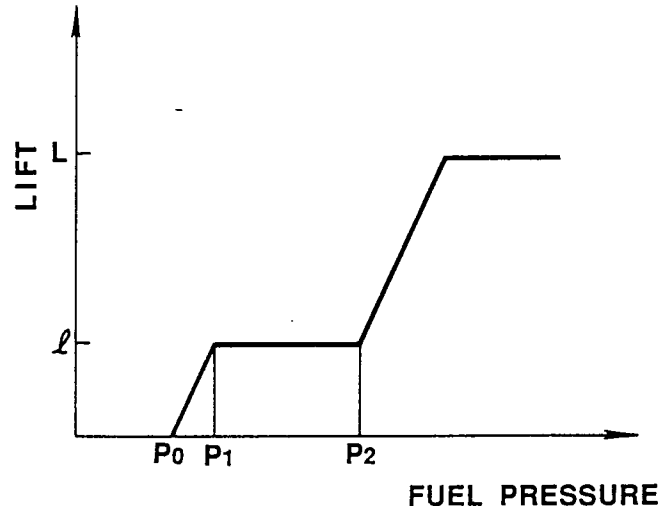

**FIG. 3**

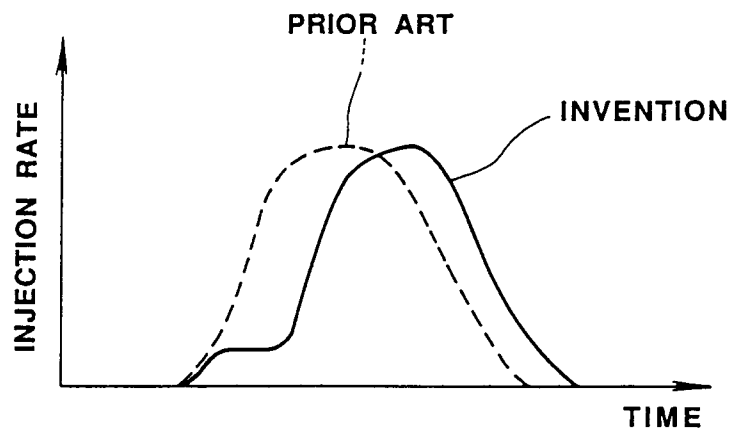

**FIG. 4**

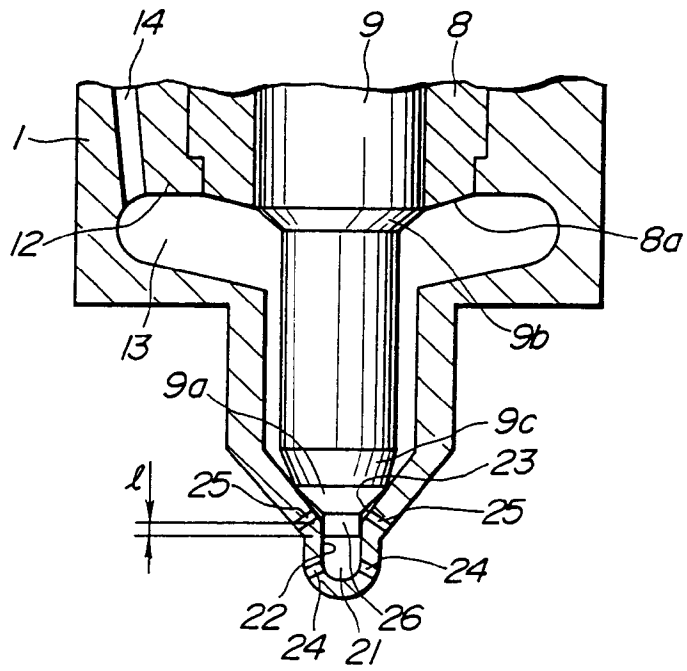

**FIG. 5**

