



(22) Date de dépôt/Filing Date: 2007/10/22

(41) Mise à la disp. pub./Open to Public Insp.: 2009/04/22

(51) Cl.Int./Int.Cl. *F04B 17/00* (2006.01),  
*A61M 1/10* (2006.01), *F04D 29/18* (2006.01),  
*F04D 29/66* (2006.01), *F04D 3/02* (2006.01),  
*H02K 21/12* (2006.01), *H02K 7/14* (2006.01)

(71) Demandeur/Applicant:  
SUNATORI, GO SIMON, CA

(72) Inventeur/Inventor:  
SUNATORI, GO SIMON, CA

(54) Titre : POMPE A VIS A SPIRALE D'ARCHIMEDE A ENTRAINEMENT MAGNETIQUE

(54) Title: MAGNETICALLY DRIVEN ARCHIMEDES SPIRAL SCREW PUMP

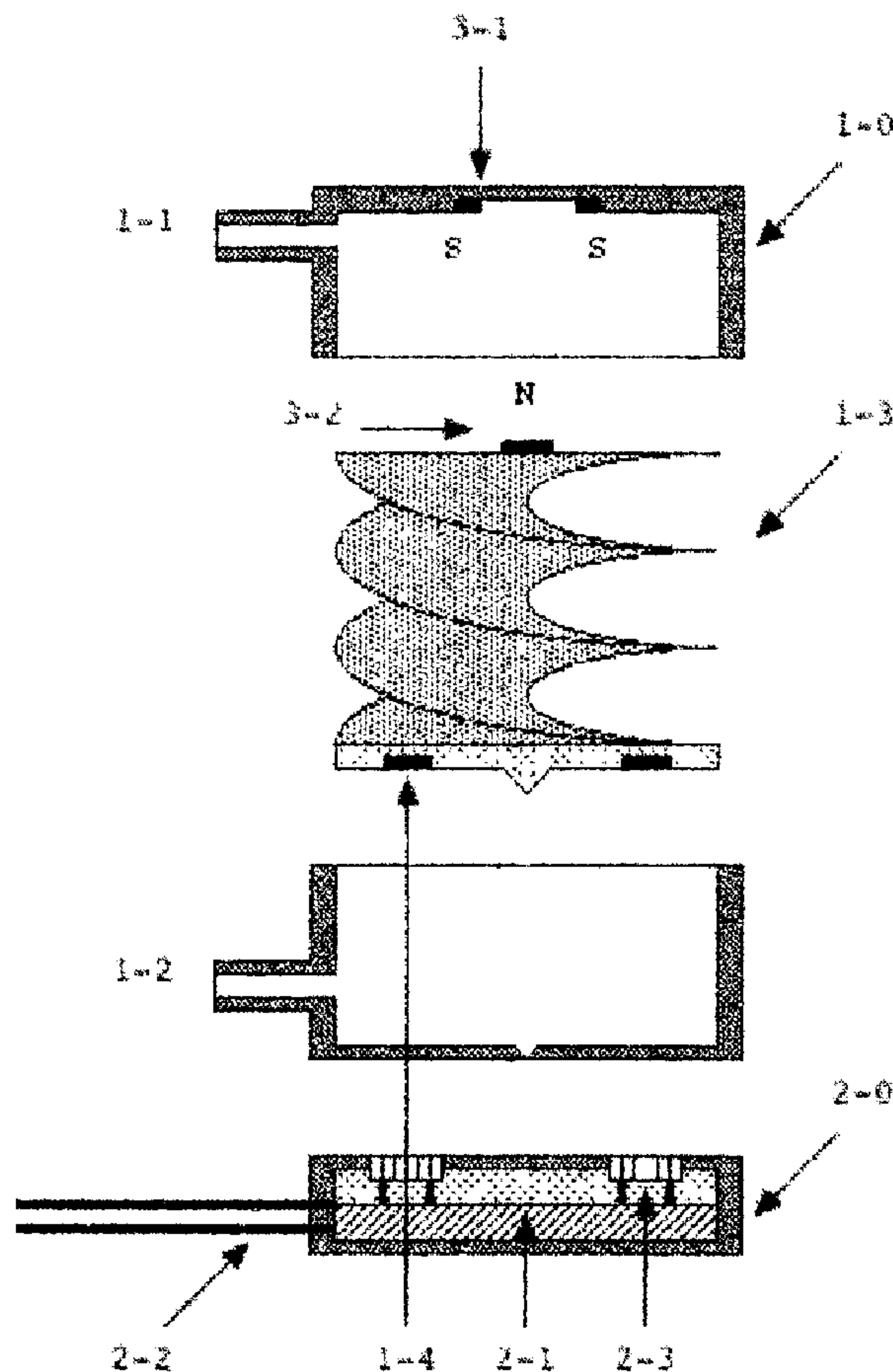

(57) Abrégé/Abstract:

• A pump system comprises a pump assembly and a control assembly. The pump assembly comprises a casing, a helical vane for moving fluid, and a permanent magnet. The casing has a fluid inlet and a fluid outlet. The helical vane is housed inside the casing.

(57) **Abrégé(suite)/Abstract(continued):**

The permanent magnet is securely attached to the bottom portion of the helical vane. The control assembly comprises a casing, a control circuitry, and a plurality of electromagnets. The electromagnets are securely attached to the top portion of the casing. The helical vane is capable of minimising turbulent flow and of maximising laminar flow inside the pump assembly. The control circuitry is capable of generating magnetic field by energising the electromagnets. Sequentially changing magnetic field of the electromagnets causes the helical vane to rotate. This invention relates to pump systems with an Archimedes spiral screw, and the principal use of the invention is for circulating fluid.

**Abstract**

- A pump system comprises a pump assembly and a control assembly. The pump assembly comprises a casing, a helical vane for moving fluid, and a permanent magnet. The casing has a fluid inlet and a fluid outlet. The helical vane is housed inside the casing. The permanent magnet is securely attached to the bottom portion of the helical vane. The control assembly comprises a casing, a control circuitry, and a plurality of electromagnets. The electromagnets are securely attached to the top portion of the casing. The helical vane is capable of minimising turbulent flow and of maximising laminar flow inside the pump assembly. The control circuitry is capable of generating magnetic field by energising the electromagnets. Sequentially changing magnetic field of the electromagnets causes the helical vane to rotate. This invention relates to pump systems with an Archimedes spiral screw, and the principal use of the invention is for circulating fluid.

## **Description**

### **Title**

- **Magnetically Driven Archimedes Spiral Screw Pump**

### **Technical Field**

- This invention relates to pump systems for circulating fluid, more particularly to a pump system with an Archimedes spiral screw.

### **Background Art**

- There are many instances where it would be desirable to be able to move fluids with a magnetically-driven Archimedes spiral screw as a fluid mover in ultra-long life, ultra-low wear pumps.
- A number of patents disclose various systems for moving fluids with helical vanes.
- **U.S. Patent 4 239 449** discloses "Screw pump construction". A hydraulic screw pump is provided having a rotatable screw which may comprise a helical blade disposed within an enclosed full or open half cylinder. In half-cylindrical constructions the helical blade rotates relative to a half cylinder which may be formed of concrete. The enclosed screw pumps may have the helical blades welded to the inner periphery of a surrounding metal cylinder so as to rotate therewith, or be welded to said surrounding metal cylinder and also to an inner cylinder which provides axial reinforcement.
- **U.S. Patent 4 957 504** discloses "Implantable blood pump". The pump includes a stator having a cylindrical opening, an annular array of electromagnets carried by the stator concentric with the cylindrical opening and lying in a plane transverse to the axis of the opening, a bearing carried by the stator and extending across the cylindrical opening, and a rotor supported by the bearing for rotation about the axis of the cylindrical opening, the rotor being in the form of an Archimedes screw and having a permanent magnet in its periphery which lies in the same plane as the array of electromagnets.
- **U.S. Patent 6 447 275** discloses "Screw pump". A screw pump includes a screw rotatably arranged in a housing, the threads of which are partially in engagement with a rotatable sealing device having radial sealing discs, whereby the screw area of the screw, including thread grooves and thread walls, are

formed by a generatrix which is a part of a circle arc, the circle of which is rotatable around an eccentric rotation axis when the generatrix rotates around the axis of the screw and is displaced along this with a velocity being proportional to the rotational velocity of the screw.

- **U.S. Patent 6 527 699** discloses "Magnetic suspension blood pump". This invention is a non-contact axial flow turbo blood pump for propelling blood, which is composed of a pump housing that defines a pump axis, with inlet, outlet openings at opposite axial ends of the pump housing, a rotor unit that defines a rotor axis, and opposing rotor axial ends. The pump magnetically suspends the rotor within the pump housing at the rotor axial ends so as to avoid causing physical contact between the housing to define fluid gaps between the rotor axial ends, and the magnetic suspension elements.
- **Canadian Patent 2 327 490** discloses "Magnetically Erected Wind-Effect Display Device". The wind-effect element of the rotor assembly is capable of rotating around the central axis of rotation by an external force exerted by wind pressure. This prior art demonstrates the effectiveness of the helical vane with magnetic bearing for moving fluid.
- These prior art arrangements do not have a pump system having Archimedes spiral screw with edge-energisation and passive magnetic bearing. The impeller used in conventional centrifugal pumps causes turbulent flow with high level of noise and vibration, and may create cavitation which leads to short life and high wear of the pump mechanism.

#### **Description of the Invention**

- It is a primary object of the invention to provide a pump system for circulating fluid with an Archimedes spiral screw.
- It is another object of the invention to provide a pump system with a helical vane which is capable of minimising turbulent flow and of maximising laminar flow.
- It is another object of the invention to provide a pump system with a helical vane which is housed in a casing without penetration of a shaft seal which causes liquid leak.
- It is another object of the invention to provide a pump system with a helical vane which has permanent magnets to be driven by electromagnets.
- It is another object of the invention to provide a pump system with a helical vane which rotates around a rotational axis by sequentially changing magnetic field of the electromagnets.

- It is another object of the invention to provide a pump system with passive magnetic bearing in order to avoid physical contact.
- A pump system comprises a pump assembly and a control assembly. The pump assembly comprises a casing, a helical vane for moving fluid, and a permanent magnet. The casing has a fluid inlet and a fluid outlet. The helical vane is housed inside the casing. The permanent magnet is securely attached to the bottom portion of the helical vane. The control assembly comprises a casing, a control circuitry, and a plurality of electromagnets. The electromagnets are securely attached to the top portion of the casing. The helical vane is capable of minimising turbulent flow and of maximising laminar flow inside the pump assembly. The control circuitry is capable of generating magnetic field by energising the electromagnets. Sequentially changing magnetic field of the electromagnets causes the helical vane to rotate.

#### **Brief Description of the Figures in the Drawings**

- In drawings which illustrate embodiments of the invention:
  - **Figure 1** is a perspective view of one embodiment of a magnetically-driven Archimedes spiral screw pump according to the invention;
  - **Figure 2** is an exploded sectional view of one embodiment of a magnetically-driven Archimedes spiral screw pump according to the invention;
  - **Figure 3** is an exploded sectional view of another embodiment of a magnetically-driven Archimedes spiral screw pump according to the invention;
  - **Figure 4** is a bottom view of the helical vane with permanent magnets; and
  - **Figure 5** is a top view of the control assembly with electromagnets.

#### **Modes for Carrying Out the Invention**

- In one embodiment of the invention shown in **Figure 1**, a pump system for circulating fluid comprises a pump assembly and a control assembly.
- **Figure 2** shows one embodiment of the pump system. **Figure 3** shows another embodiment of the pump system.
- The pump assembly comprises a casing 1-0, a helical vane 1-3 for moving fluid, and a permanent magnet 1-4.

- The casing 1-0 has a top portion and a bottom portion. The casing 1-0 has a fluid inlet 1-1 and a fluid outlet 1-2.
- The helical vane 1-3 has a top portion, a bottom portion and a rotational axis. The helical vane 1-3 is housed inside the casing 1-0.
- The permanent magnet 1-4 is securely attached to the bottom portion of the helical vane 1-3, as shown in **Figure 4**.
- The control assembly comprises a casing 2-0, a control circuitry 2-1, a set of electrical cables 2-2 for providing electrical power and control signals, and a plurality of electromagnets 2-3.
- The casing 2-0 has a top portion. The top portion of the casing 2-0 is securely attached to the bottom portion of the casing 1-0 of the pump assembly.
- The control circuitry 2-1 is securely housed inside the casing.
- The electrical cables 2-2 are electrically connected to the control circuitry 2-1.
- The electromagnets 2-3 are securely attached to the top portion of the casing 2-0, as shown in **Figure 5**. The electromagnets 2-3 are electrically connected to the control circuitry 2-1.
- According to the present invention, the helical vane 1-3 of the pump assembly is capable of minimising turbulent flow and of maximising laminar flow inside the pump assembly.
- The control circuitry 2-1 of the control assembly is capable of generating magnetic field by energising the electromagnets 2-3 of the control assembly.
- Sequentially changing magnetic field of the electromagnets 2-3 of the control assembly causes the helical vane 1-3 of the pump assembly to rotate around the rotational axis.
- The permanent magnet 1-4 of the pump assembly may be disc-shaped. Alternatively, the permanent magnet 1-4 of the pump assembly may be a single magnet with multiple polarisation areas.
- Preferably, the permanent magnet 1-4 of the pump assembly is made of a rare-earth magnet.
- The electrical cables 2-2 of the control assembly may provide AC electrical power. Alternatively, the electrical cables 2-2 of the control assembly may provide DC electrical power.

- Each electromagnet 2-3 of the control assembly may be a coreless coil.
- The pump system may further comprise a first magnetic element 3-1 and a second magnetic element 3-2, as shown in **Figure 3**.
- The first magnetic element 3-1 has N and S poles. The first magnetic element 3-1 is securely attached to the top portion of the casing 1-0 of the pump assembly.
- The second magnetic element 3-2 has N and S poles. The second magnetic element 3-2 is securely attached to the top portion of the helical vane 1-3 of the pump assembly.
- Magnetic repulsion force between the first magnetic element 3-1 and the second magnetic element 3-2 forms passive magnetic bearing in order to avoid physical contact.
- The first magnetic element 3-1 may be ring-shaped. The second magnetic element 3-2 may be disc-shaped.
- The first magnetic element 3-1 may be made of a rare-earth magnet. The second magnetic element 3-2 may be made of a rare-earth magnet.

## Claims

- The embodiments of the invention in which an exclusive property or privilege is claimed are defined as follows:

1. A pump system for circulating fluid, comprising:

- a pump assembly comprising:

- a casing having a top portion and a bottom portion, the casing having a fluid inlet and a fluid outlet;
- a helical vane for moving fluid, the helical vane having a top portion, a bottom portion and a rotational axis, the helical vane housed inside the casing; and
- a permanent magnet securely attached to the bottom portion of the helical vane; and

- a control assembly comprising:

- a casing having a top portion, the top portion of the casing securely attached to the bottom portion of the casing of the pump assembly;
- a control circuitry securely housed inside the casing;
- a set of electrical cables for providing electrical power and control signals, the electrical cables electrically connected to the control circuitry; and
- a plurality of electromagnets securely attached to the top portion of the casing, the electromagnets electrically connected to the control circuitry;

the helical vane of the pump assembly being capable of minimising turbulent flow and of maximising laminar flow inside the pump assembly, the control circuitry of the control assembly being capable of generating magnetic field by energising the electromagnets of the control assembly, sequentially changing magnetic field of the electromagnets of the control assembly causing the helical vane of the pump assembly to rotate around the rotational axis.

2. The pump system as defined in claim 1, in which the permanent magnet of the pump assembly is disc-shaped.
3. The pump system as defined in claim 1, in which the permanent magnet of the pump assembly is a single magnet with multiple polarisation areas.

4. The pump system as defined in claim 1, in which the permanent magnet of the pump assembly is made of a rare-earth magnet.
5. The pump system as defined in claim 1, in which the electrical cables of the control assembly provide AC electrical power.
6. The pump system as defined in claim 1, in which the electrical cables of the control assembly provide DC electrical power.
7. The pump system as defined in claim 1, in which each electromagnet of the control assembly is a coreless coil.
8. The pump system as defined in claim 1, further comprising:
  - a first magnetic element having N and S poles, the first magnetic element securely attached to the top portion of the casing of the pump assembly; and
  - a second magnetic element having N and S poles, the second magnetic element securely attached to the top portion of the helical vane of the pump assembly;

magnetic repulsion force between the first magnetic element and the second magnetic element forming passive magnetic bearing in order to avoid physical contact.
9. The pump system as defined in claim 8, in which the first magnetic element is ring-shaped.
10. The pump system as defined in claim 8, in which the second magnetic element is disc-shaped.
11. The pump system as defined in claim 8, in which the first magnetic element is made of a rare-earth magnet.
12. The pump system as defined in claim 8, in which the second magnetic element is made of a rare-earth magnet.

Figure 1

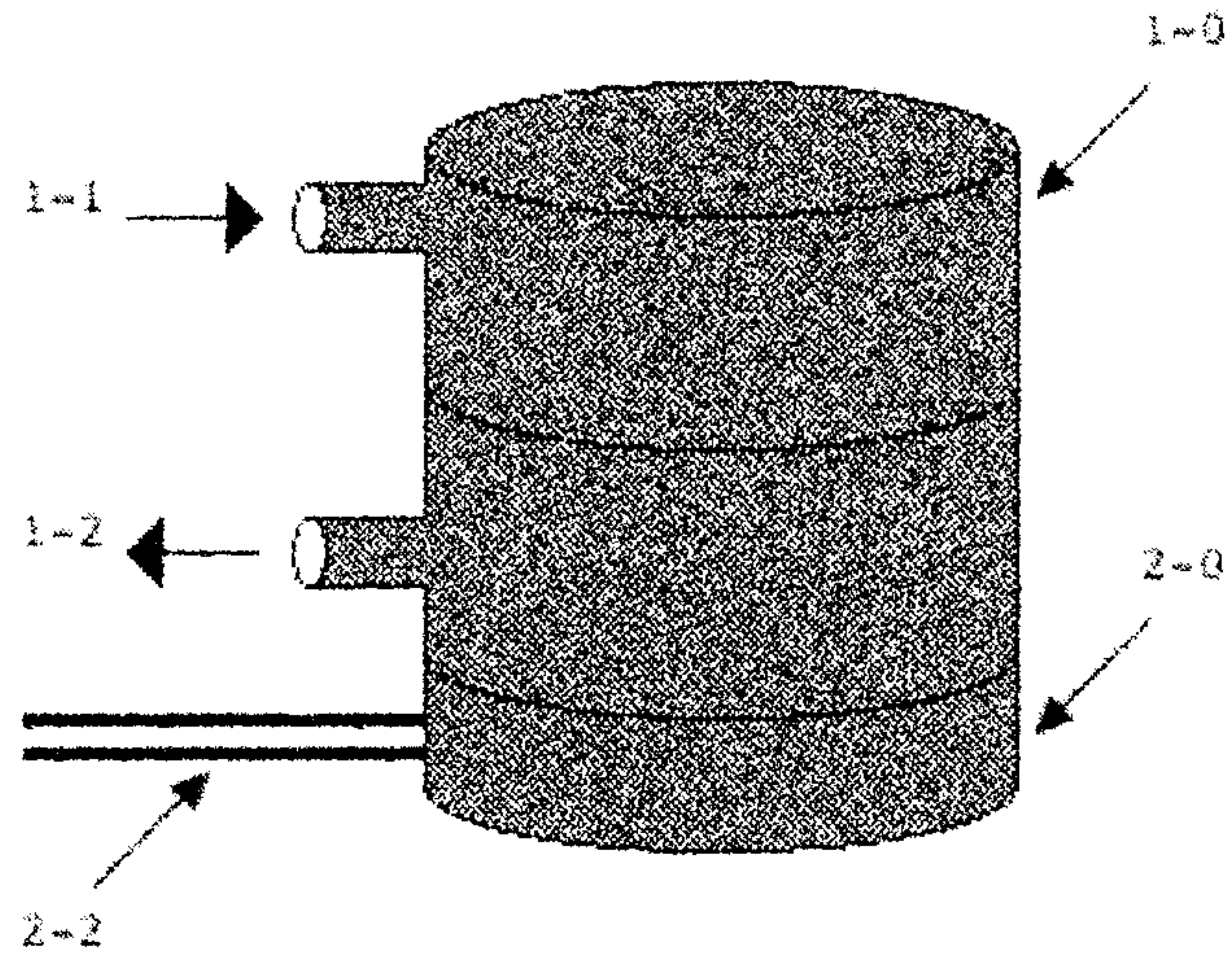

Figure 2

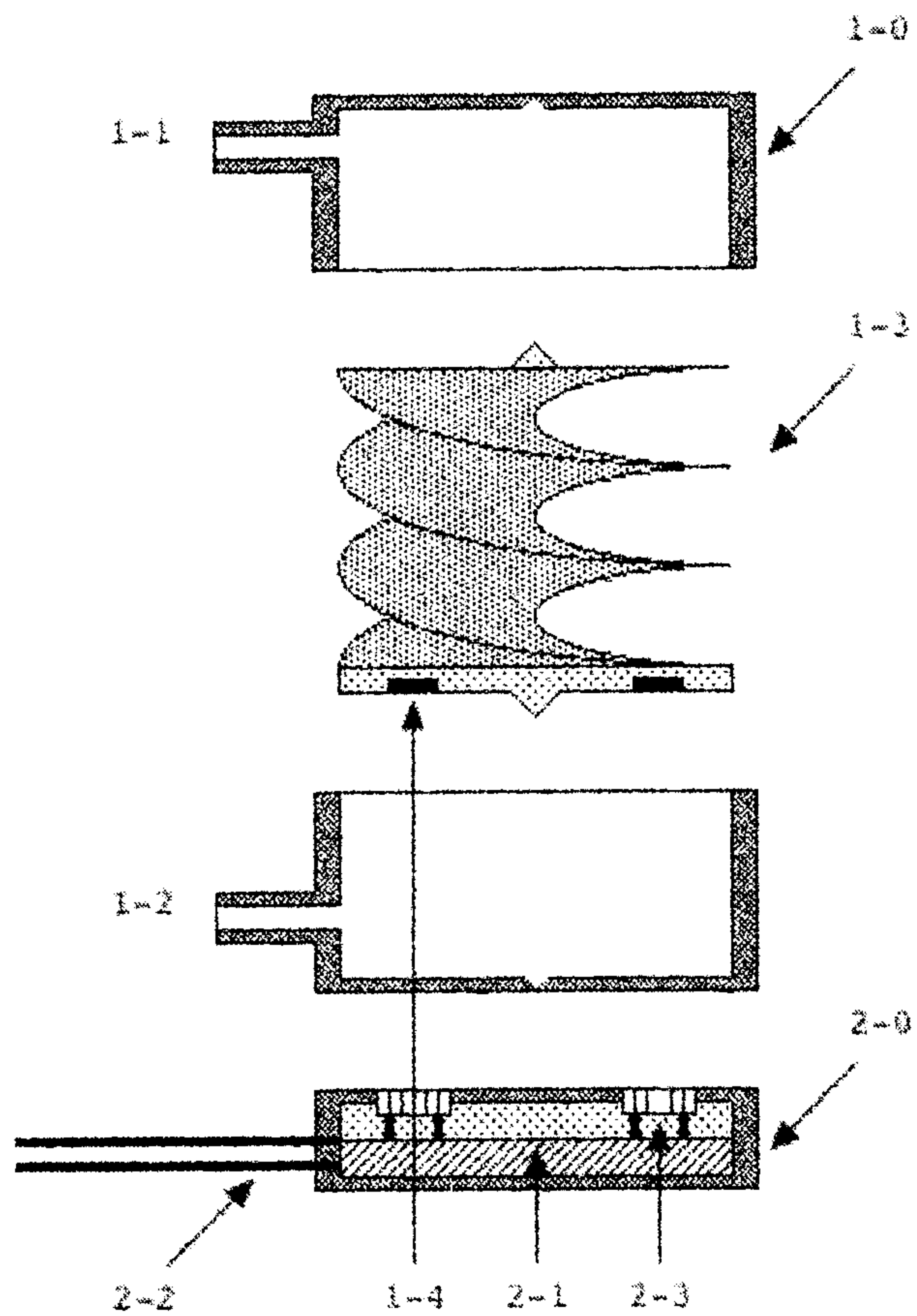

Figure 3

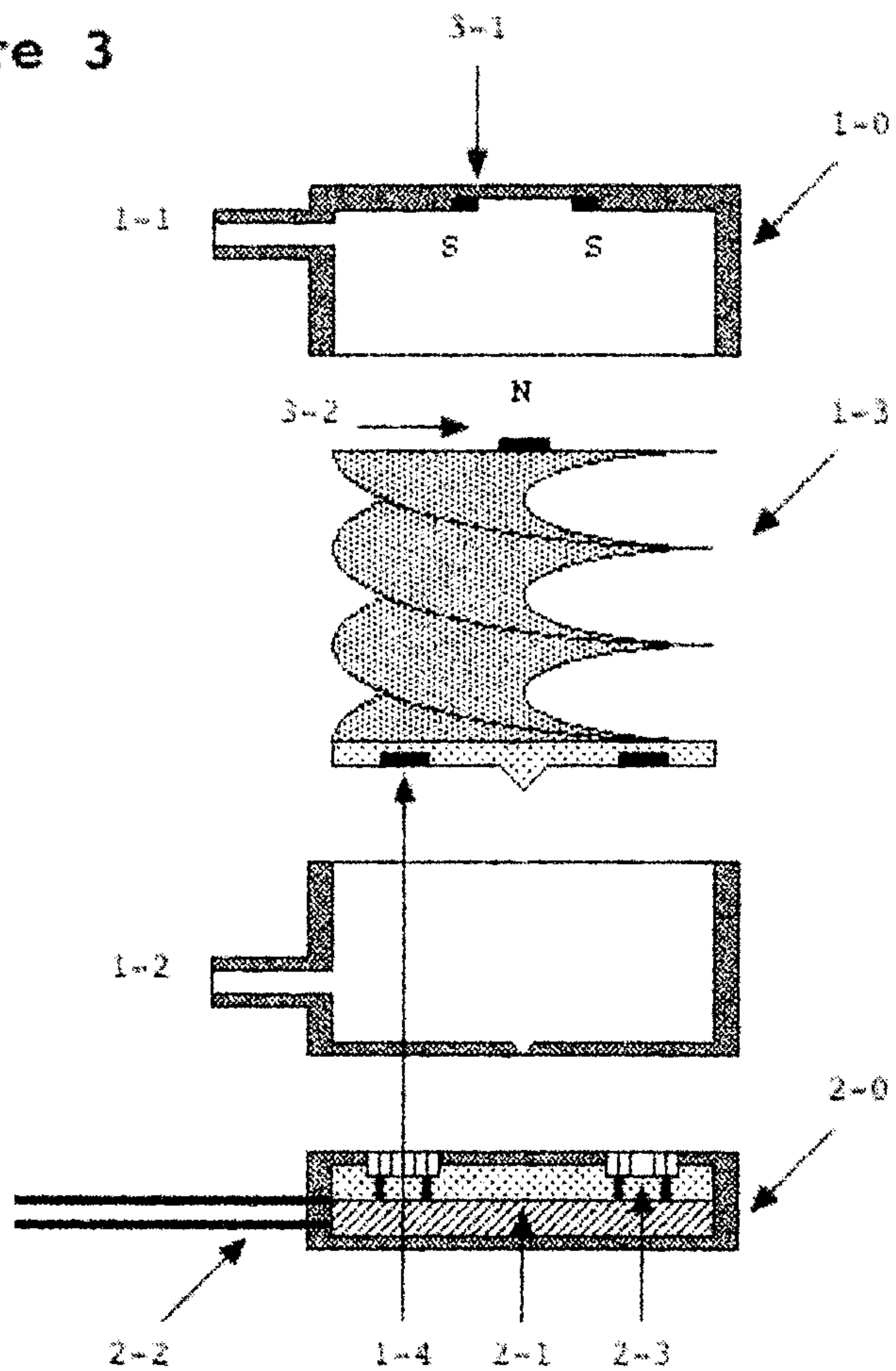

Figure 4

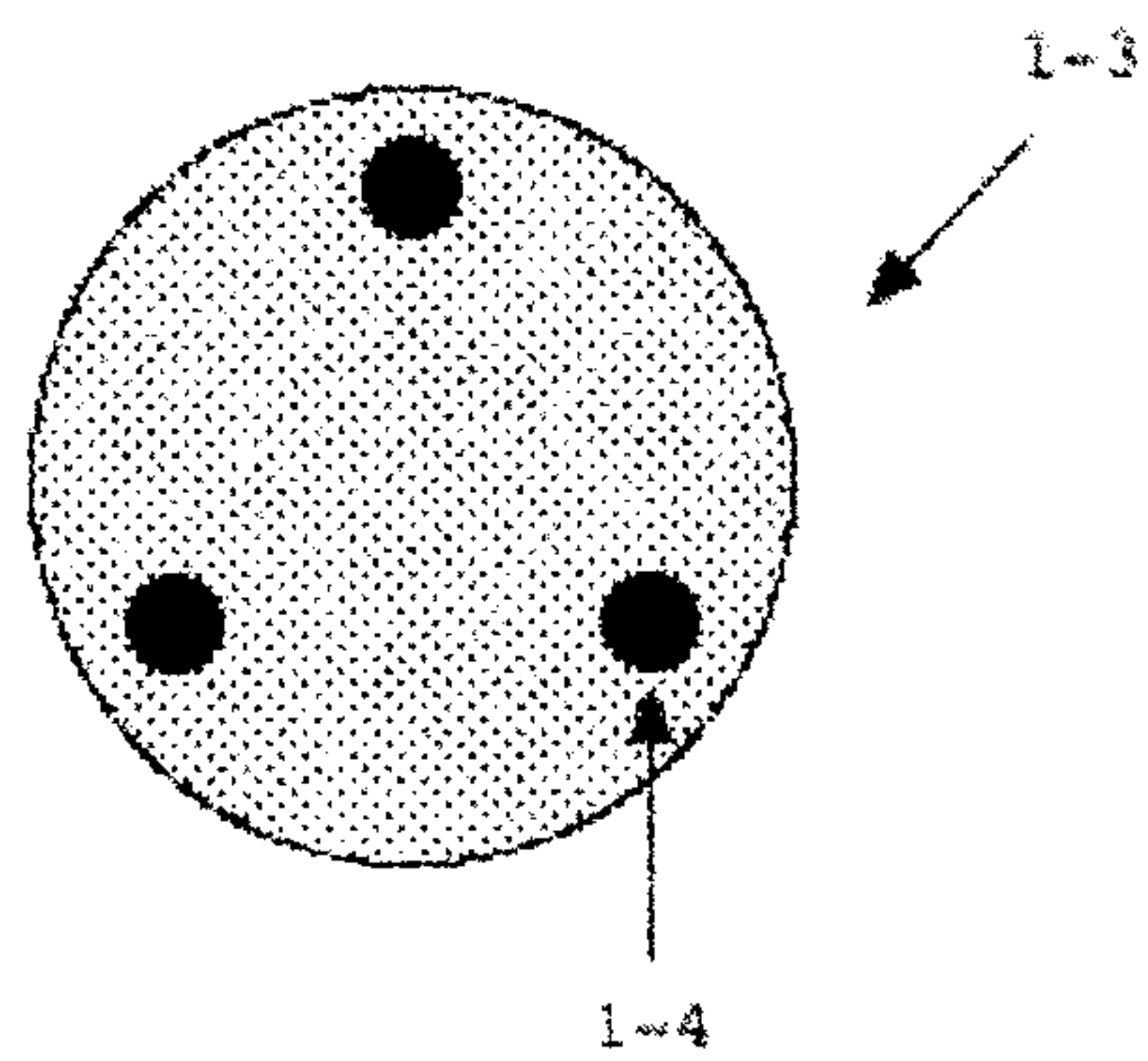

Figure 5

