



- (51) International Patent Classification:
H04W 74/00 (2009.01) *H04W 74/08* (2009.01)
- (21) International Application Number:
PCT/EP2020/072799
- (22) International Filing Date:
13 August 2020 (13.08.2020)
- (25) Filing Language: English
- (26) Publication Language: English
- (30) Priority Data:
19191858.0 14 August 2019 (14.08.2019) EP
- (71) Applicant: **FRAUNHOFER-GESELLSCHAFT ZUR FÖRDERUNG DER ANGEWANDTEN FORSCHUNG E.V.** [DE/DE]; Hansastraße 27c, 80686 München (DE).
- (72) Inventors: **FEHRENBACH, Thomas**; c/o Fraunhofer-Institut für Nachrichtentechnik, Heinrich-Hertz-Institut, HHI, Einsteinufer 37, 10587 Berlin (DE). **GÖKTEPE, Baris**;

c/o Fraunhofer-Institut für Nachrichtentechnik, Heinrich-Hertz-Institut, HHI, Einsteinufer 37, 10587 Berlin (DE). **HELLGE, Cornelius**; c/o Fraunhofer-Institut für Nachrichtentechnik, Heinrich-Hertz-Institut, HHI, Einsteinufer 37, 10587 Berlin (DE). **WIRTH, Thomas**; c/o Fraunhofer-Institut für Nachrichtentechnik, Heinrich-Hertz-Institut, HHI, Einsteinufer 37, 10587 Berlin (DE). **SCHIERL, Thomas**; c/o Fraunhofer-Institut für Nachrichtentechnik, Heinrich-Hertz-Institut, HHI, Einsteinufer 37, 10587 Berlin (DE). **SRINIVASAN, Nithin**; c/o Fraunhofer-Institut für Nachrichtentechnik, Heinrich-Hertz-Institut, HHI, Einsteinufer 37, 10587 Berlin (DE).

- (74) Agent: **SCHAIRER, Oliver** et al.; Schoppe, Zimmermann, Stöckeler, Zinkler, Schenk & Partner mbB, Radlkofenstr. 2, 81373 München (DE).
- (81) Designated States (*unless otherwise indicated, for every kind of national protection available*): AE, AG, AL, AM, AO, AT, AU, AZ, BA, BB, BG, BH, BN, BR, BW, BY, BZ,

(54) Title: USER DEVICE FOR WIRELESS COMMUNICATION

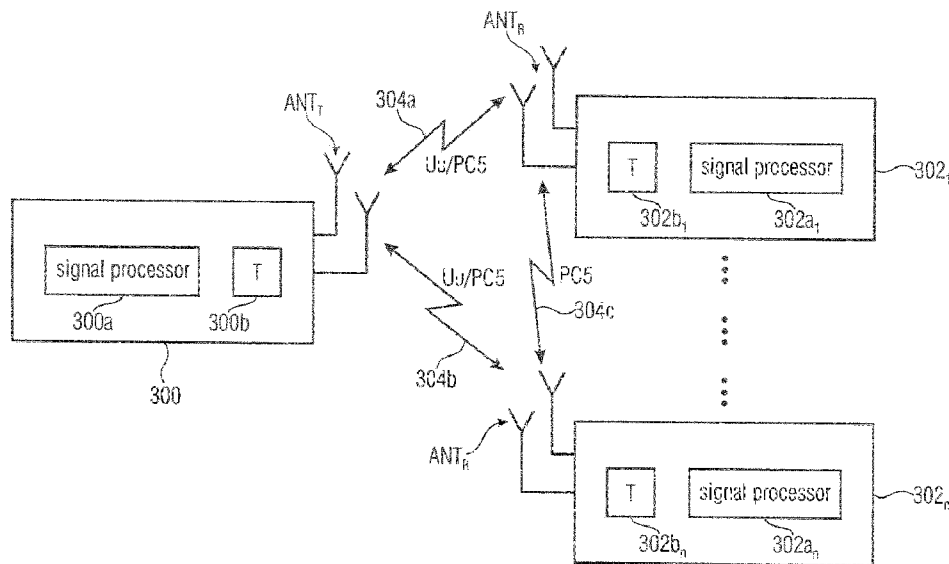

Fig. 2

(57) Abstract: A user device, UE, for a wireless communication system according to an embodiment is provided. A backoff rule is stored within a storage of a base station and within a storage of the user device. Or, the user device is to transmit the backoff rule to the base station. Or, the user device is to receive the backoff rule from the base station. The user device is to determine a random backoff counter depending on the backoff rule. Moreover, the user device is to decrement the random packet backoff counter if a transmission channel is not occupied for a certain duration. Furthermore, the user device is to transmit a data packet via the transmission channel, if the random backoff counter reaches a predefined value.



CA, CH, CL, CN, CO, CR, CU, CZ, DE, DJ, DK, DM, DO,
DZ, EC, EE, EG, ES, FI, GB, GD, GE, GH, GM, GT, HN,
HR, HU, ID, IL, IN, IR, IS, IT, JO, JP, KE, KG, KH, KN,
KP, KR, KW, KZ, LA, LC, LK, LR, LS, LU, LY, MA, MD,
ME, MG, MK, MN, MW, MX, MY, MZ, NA, NG, NI, NO,
NZ, OM, PA, PE, PG, PH, PL, PT, QA, RO, RS, RU, RW,
SA, SC, SD, SE, SG, SK, SL, ST, SV, SY, TH, TJ, TM, TN,
TR, TT, TZ, UA, UG, US, UZ, VC, VN, WS, ZA, ZM, ZW.

- (84) Designated States** (*unless otherwise indicated, for every kind of regional protection available*): ARIPO (BW, GH, GM, KE, LR, LS, MW, MZ, NA, RW, SD, SL, ST, SZ, TZ, UG, ZM, ZW), Eurasian (AM, AZ, BY, KG, KZ, RU, TJ, TM), European (AL, AT, BE, BG, CH, CY, CZ, DE, DK, EE, ES, FI, FR, GB, GR, HR, HU, IE, IS, IT, LT, LU, LV, MC, MK, MT, NL, NO, PL, PT, RO, RS, SE, SI, SK, SM, TR), OAPI (BF, BJ, CF, CG, CI, CM, GA, GN, GQ, GW, KM, ML, MR, NE, SN, TD, TG).

Published:

— *with international search report (Art. 21(3))*

USER DEVICE FOR WIRELESS COMMUNICATION

Description

5 The present application concerns the field of wireless communication systems or networks, more specifically, enhancements or improvements in the communication among entities of the wireless communication network. Embodiments concern enhancements or improvements for NR-U (New Radio in Unlicensed Spectrum) which are random number generator related according to the provided new and inventive concepts.

10

Fig. 1 is a schematic representation of an example of a terrestrial wireless network 100 including, as is shown in Fig. 1(a), a core network 102 and one or more radio access networks $RAN_1, RAN_2, \dots, RAN_N$. Fig. 1(b) is a schematic representation of an example of a radio access network RAN_n that may include one or more base stations gNB_1 to gNB_5 , each serving a specific area surrounding the base station schematically represented by respective cells 106_1 to 106_5 . The base stations are provided to serve users within a cell. The one or more base stations may serve users in licensed and/or unlicensed bands. The term base station, BS, refers to a gNB in 5G networks, an eNB in UMTS/LTE/LTE-A/ LTE-A Pro, or just a BS in other mobile communication standards. A user may be a stationary device or a mobile device. The wireless communication system may also be accessed by mobile or stationary IoT devices which connect to a base station or to a user. The mobile devices or the IoT devices may include physical devices, ground based vehicles, such as robots or cars, aerial vehicles, such as manned or unmanned aerial vehicles (UAVs), the latter also referred to as drones, buildings and other items or devices having embedded therein electronics, software, sensors, actuators, or the like as well as network connectivity that enables these devices to collect and exchange data across an existing network infrastructure. The example is not limited to terrestrial wireless networks, but network entities can involve non-terrestrial networks (NTN), where a parts of a BS, and/or BS and/or core network can be payload of a satellite (LEO, GEO, MEO) or high altitude platform (HAPs), e.g. balloon or special airplane.

30

Fig. 1(b) shows an exemplary view of five cells, however, the RAN_n may include more or less such cells, and RAN_n may also include only one base station. Fig. 1(b) shows two users UE_1 and UE_2 , also referred to as user equipment, UE, that are in cell 106_2 and that are served by base station gNB_2 . Another user UE_3 is shown in cell 106_4 which is served by base station gNB_4 . The arrows $108_1, 108_2$ and 108_3 schematically represent uplink/downlink connections for transmitting data from a user UE_1, UE_2 and UE_3 to the base stations gNB_2, gNB_4 or for transmitting data from the base stations gNB_2, gNB_4 to the users UE_1, UE_2, UE_3 .

35

This may be realized on licensed bands or on unlicensed bands. Further, Fig. 1(b) shows two IoT devices 110₁ and 110₂ in cell 106₄, which may be stationary or mobile devices. The IoT device 110₁ accesses the wireless communication system via the base station gNB₄ to receive and transmit data as schematically represented by arrow 112₁. The IoT device 110₂ accesses the wireless communication system via the user UE₃ as is schematically represented by arrow 112₂. The respective base station gNB₁ to gNB₅ may be connected to the core network 102, e.g. via the S1 interface, via respective backhaul links 114₁ to 114₅, which are schematically represented in Fig. 1(b) by the arrows pointing to "core". The core network 102 may be connected to one or more external networks. Further, some or all of the respective base station gNB₁ to gNB₅ may be connected, e.g. via the S1 or X2 interface or the XN interface in NR, with each other via respective backhaul links 116₁ to 116₅, which are schematically represented in Fig. 1(b) by the arrows pointing to "gNBs". The network can also contain UEs communicating in direct mode, also referred to as device-to-device (D2D) communication. This interface is often referred to as PC5 interface.

15

For data transmission a physical resource grid may be used. The physical resource grid may comprise a set of resource elements to which various physical channels and physical signals are mapped. For example, the physical channels may include the physical downlink, uplink and sidelink shared channels (PDSCH, PUSCH, PSSCH) carrying user specific data, also referred to as downlink, uplink and sidelink payload data, the physical broadcast channel (PBCH) carrying for example a master information block (MIB) and a system information block (SIB), the physical downlink, uplink and sidelink control channels (PDCCH, PUCCH, PSCCH) carrying for example the downlink control information (DCI), the uplink control information (UCI) and the sidelink control information (SCI). For the uplink, the physical channels may further include the physical random access channel (PRACH or RACH) used by UEs for accessing the network once a UE is synchronized and has obtained the MIB and SIB. The sidelink can also comprise the physical sidelink feedback channel (PSFCH). The physical signals may comprise reference signals or symbols (RS), synchronization signals and the like. The resource grid may comprise a frame or radio frame having a certain duration in the time domain and having a given bandwidth in the frequency domain. The frame may have a certain number of subframes of a predefined length, e.g. 1ms. Each subframe may include one or more slots of 12 or 14 OFDM symbols depending on the cyclic prefix (CP) length. A frame may also consist of a smaller number of OFDM symbols, e.g. when utilizing shortened transmission time intervals (sTTI) or a mini-slot/non-slot-based frame structure comprising just a few OFDM symbols.

35

The wireless communication system may be any single-tone or multicarrier system using frequency-division multiplexing, like the orthogonal frequency-division multiplexing (OFDM)

system, the orthogonal frequency-division multiple access (OFDMA) system, or any other IFFT-based signal with or without CP, e.g. DFT-s-OFDM. Other waveforms, like non-orthogonal waveforms for multiple access, e.g. filter-bank multicarrier (FBMC), generalized frequency division multiplexing (GFDM) or universal filtered multi carrier (UFMC), may be used. The wireless communication system may operate, e.g., in accordance with the LTE-Advanced pro standard, or the 5G or NR, New Radio, standard, or the NR-U, New Radio Unlicensed, standard, or the 802.11ax, or the 802.11be.rules

The wireless network or communication system depicted in Fig. 1 may be a heterogeneous network having distinct overlaid networks, e.g., a network of macro cells with each macro cell including a macro base station, like base station gNB_1 to gNB_5 , and a network of small cell base stations (not shown in Fig. 1), like femto or pico base stations.

In addition to the above described terrestrial wireless network also non-terrestrial wireless communication networks exist including spaceborne transceivers, like satellites, and/or airborne transceivers, like unmanned aircraft systems. The non-terrestrial wireless communication network or system may operate in a similar way as the terrestrial system described above with reference to Fig. 1, for example in accordance with the LTE-Advanced Pro standard or the 5G or NR, new radio, standard.

In mobile communication systems or networks, like those described above with reference to Fig. 1, for example in a LTE or 5G/NR network, the respective entities may communicate using one of more frequency bands. A frequency band includes a start frequency, an end frequency and all intermediate frequencies between the start and end frequencies. In other words, the start, end and intermediate frequencies may define a certain bandwidth, e.g., 20MHz. A frequency band may also be referred to as a carrier, a bandwidth part, BWP, a subband, and the like.

When using a single frequency band, the communication may be referred to as a single-band operation, e.g., a UE transmits/receives radio signals to/from another network entity on frequencies being within the 20MHz band.

When using two or more frequency bands, the communication may be referred to as a multi-band operation or as a wideband operation or as a carrier aggregation operation. The frequency bands may have different bandwidths or the same bandwidth, like 20MHz. For example, in case of frequency bands having the same bandwidths a UE may transmit/receive radio signals to/from another network entity on frequencies being within two or more of the 20MHz bands so that the frequency range for the radio communication

may be a multiple of 20MHz. The two or more frequency bands may be continuous/adjacent frequency bands or some or all for the frequency bands may be separated in the frequency domain.

- 5 The multi-band operation may include frequency bands in the licensed spectrum, or frequency bands in the unlicensed spectrum, or frequency bands both in the licensed spectrum and in the unlicensed spectrum.

Carrier aggregation, CA, is an example using two or more frequency bands in the licensed
10 spectrum and/or in the unlicensed spectrum.

5G New Radio (NR) may support an operation in the unlicensed spectrum so that a multi-band operation may include frequency bands in the unlicensed spectrum bands. This may be as NR-based access to unlicensed spectrum, NR-U, and the frequency bands may be
15 referred to as subbands. The unlicensed spectrum may include bands with a potential IEEE 802.11 coexistence, such as the 5GHz and the 6GHz bands. NR-U may support bandwidths that are an integer multiple of 20 MHz, for example due to regulatory requirements. The splitting into the subbands is performed so as to minimize interference with coexisting systems, like IEEE 802.11 systems, which may operate in one or more of the same bands
20 with the same nominal bandwidth channels, like 20 MHz channels. Other examples, of coexisting systems may use subbands having subband sizes and nominal frequencies different from the above-described IEEE 802.11 systems. For example, the unlicensed spectrum may include the 5GHz band, the 6GHz band, the 24GHz band or the 60GHz band or even higher frequency bands. Examples of such unlicensed bands include the industrial,
25 scientific and medical, ISM, radio bands reserved internationally for the use of radio frequency energy for industrial, scientific and medical purposes other than telecommunications.

During an operation using unlicensed subbands regulations may define that a Listen-before-talk, LBT, is to be performed separately per subband. This may lead to a situation in which
30 one or more of the subbands are busy or occupied due to an interference, for example, from other communication systems coexisting on the same band, like other public land mobile networks, PLMNs or systems operating in accordance with the IEEE 802.11 specification. In such a situation, the transmitter, either the transmitting gNB or the transmitting UE, is
35 only allowed to transmit on the subbands which are detected to be not busy, also referred to as subbands being free or non-occupied, as is determined by the LBT algorithm. For example for a transmission spanning more than 20MHz in the 5GHz operational unlicensed band, the transmitter, like the gNB or the UE, performs Listen-Before-Talk, LBT, separately

on each subband. Once the LBT results are available for each subband, the devices, for example, the gNB in the downlink, DL, or the UE in the uplink, UL, are allowed to transmit on these subbands which are determined to be free or unoccupied, i.e., to transmit on the “won” subband(s). No transmission is allowed on the occupied, busy or “non-won” subbands.

It is noted that the information in the above section is only for enhancing the understanding of the background of the invention and therefore it may contain information that does not form prior art that is already known to a person of ordinary skill in the art.

In the 3GPP New Radio unlicensed (NR-U) and legacy standards, the transmission from a UE as well as a gNB is also dependent on the outcome of the listen before talk (LBT) procedure.

This procedure uses a random backoff to limit collisions during channel access. This randomness limits scheduler efficiency as the backoff time may not be known by other transmitters in the network.

Starting from a prior art as described above, there may be a need for improvements for the devices and for methods in a wireless communication system.

A user device, UE, for a wireless communication system according to an embodiment is provided. A backoff rule is stored within a storage of a base station and within a storage of the user device. Or, the user device is to transmit the backoff rule to the base station. Or, the user device is to receive the backoff rule from the base station. The user device is to determine a random backoff counter depending on the backoff rule. Moreover, the user device is to decrement the random backoff counter if a transmission channel is not occupied for a certain duration. Furthermore, the user device is to transmit a data packet via the transmission channel, if the random backoff counter reaches a predefined value.

Moreover, a base station, gNB, for a wireless communication system according to an embodiment is provided. A backoff rule is stored within a storage of the base station and within a storage of a user device. Or, the base station is to receive the backoff rule from the user device. Or, the base station is to transmit the backoff rule to the user device. The user device is to determine a random backoff counter depending on the backoff rule and is to start a transmission of a data packet via a transmission channel depending on the backoff counter and depending on whether or not the transmission channel is occupied.

Furthermore, a method for operating a wireless communication system according to an embodiment is provided. The method comprises:

- 5 - Storing a backoff rule within a storage of a base station and within a storage of a user device; or transmitting the backoff rule from the user device to the base station; or receiving the backoff rule at the user device from the base station.
- 10 - Determining, by the user device, a random backoff counter depending on the backoff rule.
- Decrementing, by the user device, the random backoff counter if a transmission channel is not occupied for a certain duration.
- 15 - Transmitting, by the user device, a data packet via the transmission channel, if the random backoff counter reaches a predefined value.

Moreover, a method for operating a wireless communication system according to an embodiment is provided. The method comprises:

- 20 - Storing a backoff rule within a storage of a base station and storing the backoff rule within a storage of a user device; or receiving the backoff rule from the user device at the base station; or transmitting the backoff rule from the base station to the user device.

25 The user device determines a random backoff counter depending on the backoff rule and starts a transmission of a data packet via a transmission channel depending on the backoff counter and depending on whether or not the transmission channel is occupied.

30 Furthermore, a computer program product comprising instructions which, when the program is executed by a computer, causes the computer to carry out one or more of the above-described methods is provided.

Embodiments of the present invention are now described in further detail with reference to the accompanying drawings:

35

Fig. 1 illustrates a schematic representation of an example of a wireless communication system.

- Fig. 2 illustrates a schematic representation of a wireless communication system including a transceiver, like a base station, and one or more transceivers, like user devices, UEs.
- 5 Fig. 3 illustrates an example of a computer system on which units or modules as well as the steps of the methods described in accordance with the inventive approach may execute.
- 10 Fig. 4 illustrates to user devices, UEs, having a random backoff timer and a base station according to an embodiment.

Embodiments of the present invention are now described in more detail with reference to the accompanying drawings in which the same or similar elements have the same reference
15 signs assigned.

Embodiments of the present invention may be implemented in a wireless communication system as depicted in Fig. 1 including base stations and users, like mobile terminals or IoT devices. Fig. 2 is a schematic representation of a wireless communication system including
20 a transceivers 300, like a base station, and one or more other transceivers 302₁ to 302_n, like user devices, UEs. The base station 300 and the user devices 302 may communicate via one or more wireless communication links or channels 304a, 304b, 304c, like a radio link. The base station 300 may include one or more antennas ANT_T or an antenna array having a plurality of antenna elements, a signal processor 300a and a transceiver unit 300b,
25 coupled with each other. The user devices 302 include one or more antennas ANT_R or an antenna array having a plurality of antennas, a signal processor 302a₁, 302a_n, and a transceiver unit 302b₁, 302b_n coupled with each other. The base station 300 and the UEs 302 may communicate via respective first wireless communication links 304a and 304b, like a radio link using the Uu interface, while the UEs 302 may communicate with each other via
30 a second wireless communication link 304c, like a radio link using the PC5 interface. When the UEs 302 are not served by the base station 300, are not be connected to a base station, for example, they are not in an RRC connected state wrt. the network, or, more generally, when no resource allocation configuration or assistance is provided by the base station 300, the UEs 302 may communicate with each other over the sidelink directly. The system, the
35 one or more UEs 302 and the base stations 300 may operate in accordance with the inventive teachings described herein.

A user device, UE, for a wireless communication system according to an embodiment is provided. The user device may, e.g., be one of the user devices 302₁, ... 302_n of Fig. 2, for example, user device 302₁.

5 A backoff rule is stored within a storage of a base station 300 and within a storage of the user device. Or, the user device transmits the backoff rule to the base station 300. Or, the user device receives the backoff rule from the base station 300.

The user device 302₁ determines a random backoff counter depending on the backoff rule.
10 (For example, the signal processor 302a₁ of the user device 302₁ may determine the random backoff counter.)

Moreover, the user device 302₁ decrements the random backoff counter if a transmission channel is not occupied for a certain duration.

15

Furthermore, the user device 302₁ transmits a data packet via the transmission channel (e.g., using its transceiver unit 302b₁), if the random backoff counter reaches a predefined value.

20 Embodiments are based on the finding that it is useful that the base station is in possession of the backoff rule according to which the user device determines the random backoff counter. Being in possession of the backoff rule of the user device allows to enhance the capabilities of the base station. For example, the base station can (at least roughly) estimate the duration of the time period during which the user device defers a transmission in case
25 of an occupied. Or, the base station can, for example, estimate an average delay of a planned transmission at the user devices, etc. On the other hand, with respect to the user device, it is necessary that the user device obeys the backoff rule which is known by the base station so that the base station can conduct proper estimations/determinations of backoff times.

30

According to an embodiment, the user device 302₁ does not change the random backoff counter while the transmission channel is occupied.

In an embodiment, the predefined value is zero.

35

According to an embodiment, the certain duration may depend on a transmission priority for transmitting the data packet.

For example, the transmission priority may, e.g., be a priority value, e.g., an integer value between 1 and 4 (1; 2; 3; 4). Priority value 1 may indicate highest priority; priority value 4 may, e.g., indicate lowest priority. If a transmission has, e.g., priority value 4, the user device may, e.g., decrement the random backoff counter after determining that four listen-before-talk slots of the transmission channel have not been occupied. If a transmission has, e.g., priority value 3, the user device may, e.g., decrement the random backoff counter after determining that three listen-before-talk slots of the transmission channel have not been occupied. If a transmission has, e.g., priority value 2, the user device may, e.g., decrement the random backoff counter after determining that two listen-before-talk slots of the transmission channel have not been occupied. And, if a transmission has, e.g., priority value 1, the user device may, e.g., decrement the random backoff counter after determining that one listen-before-talk slot of the transmission channel has not been occupied.

In some embodiments, the random backoff counter may, e.g., be determined pre-backoff. That means, when the user device 302 intends to transmit, the random backoff counter is determined, then backoff and sensing takes place, wherein the duration depends on the random backoff counter and the priority of the transmission, and then, the transmission is conducted by the user equipment.

In other embodiments, the random backoff counter may, e.g., be determined post-backoff. That means, after backoff, channel sensing and transmission has been conducted, the random backoff counter is immediately been determined, even without that the user device intends to immediately transmit a further data packet. Then the backoff counter is decremented, if the channel is determined to be free for a certain duration, up to reaching a another predefined value which is larger than the predefined value at which the user device would start transmitting. When later on, the user device 302 intends to transmit a further data packet, sensing takes place, wherein the duration depends on the remaining value of the already determined random backoff counter, and then, the transmission of the further packet is conducted by the user equipment.

According to an embodiment, the user device 302₁ may transmit the data packet via the transmission channel to the base station 300, if the random backoff counter reaches the predefined value.

In an embodiment, the backoff rule may comprise a pseudo random number generator algorithm. The pseudo random number generator algorithm is stored within the storage of the base station 300 and is stored within the storage of the user device 302₁. Or, the user device 302₁ is may transmit the pseudo random number generator algorithm or an algorithm

indication indicating the pseudo random number generator algorithm to the base station 300. Or, the user device 302₁ may receive the pseudo random number generator algorithm or the algorithm indication indicating the pseudo random number generator algorithm from the base station 300.

5

The pseudo random number algorithm may, e.g., be specified or may, e.g., be pre-configured.

10

According to an embodiment, the pseudo random number generator algorithm may e.g., be a Gold sequence generator algorithm. Or, the pseudo random number generator algorithm may e.g., be a Mersenne-Twister algorithm. Or, the pseudo random number generator algorithm may e.g., be a xorshift generator algorithm. Or, the pseudo random number generator algorithm may e.g., be a WELL generator algorithm.

15

In an embodiment, the backoff rule comprises a seed. The seed may e.g., be stored within the storage of the base station 300 and may e.g., be stored within the storage of the user device 302₁. Or, the user device may transmit the seed to the base station 300. Or, the user device 302₁ may receive the seed from the base station 300.

20

In embodiments, at least parts of the seed may, e.g., need to be dynamic.

According to an embodiment, the user device 302₁ may e.g., be preconfigured with the pseudo random number generator algorithm and/or with seed information, wherein the seed depends on the seed information.

25

In general, different user devices within a wireless network may, e.g., have different seeds.

30

In an embodiment, the seed may depend on information that is available at the user device 302₁ and the base station 300, or on information that the user device 302₁ may transmit to the base station 300, or on information that the user device 302₁ may receive from the base station 300.

According to an embodiment, the seed may depend on one or more of:

35

- a user identifier, user ID, and/or a user device specific radio network temporary identifier, RNTI,
- a cell identifier, cell ID ,

- timing information, which, for example, depends on an OFDM symbol number and/or a slot number and/or a subframe number and/or a frame number,
- 5 ○ the seed, wherein the user device 302₁ is to receive the seed from the base station 300,
- 10 ○ the seed, wherein the seed is user-device-generated, and the user device 302₁ is to transmit the seed to the base station 300.

In an embodiment, the user device 302₁ may communicate over a sidelink or over a D2D interface, wherein, for example, the base station 300 is another user device. The other user device may, e.g., be a RSU road side unit or a Group leader UE (V2X), or a Master UE, or a iPhone® communication with watch, or a IoT master (IoT node with good connectivity).

Moreover, a base station 300, gNB, for a wireless communication system according to an embodiment is provided.

20 A backoff rule is stored within a storage of the base station 300 and within a storage of a user device 302₁. Or, the base station 300 receives the backoff rule from the user device 302₁. Or, the base station 300 transmits (e.g., using its transceiver unit 300b) the backoff rule to the user device 302₁. The user device 302₁ determines a random backoff counter depending on the backoff rule and is to start a transmission of a data packet via a transmission channel depending on the backoff counter and depending on whether or not the transmission channel is occupied.

30 According to an embodiment, the backoff rule may, e.g., comprise a pseudo random number generator algorithm. The pseudo random number generator algorithm is stored within the storage of the base station 300 and is stored within the storage of the user device 302₁. Or, the base station 300 may receive the pseudo random number generator algorithm or an algorithm indication indicating the pseudo random number generator algorithm from the user device 302₁. Or, the base station 300 may transmit the pseudo random number generator algorithm or the algorithm indication indicating the pseudo random number generator algorithm to the user device 302₁.

In an embodiment, the pseudo random number generator algorithm may e.g., be a Gold sequence generator algorithm. Or, the pseudo random number generator algorithm may

e.g., be a Mersenne-Twister algorithm. Or, the pseudo random number generator algorithm may e.g., be a xorshift generator algorithm. Or the pseudo random number generator algorithm may e.g., be a WELL generator algorithm.

- 5 According to an embodiment, the backoff rule comprises a seed. The seed may e.g., be stored within the storage of the base station 300 and may e.g., be stored within the storage of the user device 302₁. Or, the base station 300 may receive the seed from the base station 300. Or, the base station 300 may transmit the seed to the user device 302₁.
- 10 In an embodiment, the base station 300 may e.g., be preconfigured with the pseudo random number generator algorithm and/or with seed information, wherein the seed depends on the seed information.

According to an embodiment, the seed may e.g., depend on information that is available at
15 the user device 302₁ and the base station 300, or on information that the base station 300 may transmit to the user device 302₁, or on information that the base station 300 may receive from the user device 302₁.

In an embodiment, the seed may e.g., depend on one or more of:

- 20
- a user identifier, user ID, and/or a user device specific radio network temporary identifier, RNTI,
 - a cell identifier, cell ID ,
 - 25 ○ timing information, which, for example, depends on an OFDM symbol number and/or a slot number and/or a subframe number and/or a frame number,
 - 30 ○ the seed, wherein the user device 302₁ is to receive the seed from the base station 300,
 - the seed, wherein the seed is user-device-generated, and the user device 302₁ is to transmit the seed to the base station 300.

35

According to an embodiment, the user device 302₁ is one of a plurality of user devices 302₁, ... 302_n, and the backoff rule is one of a plurality of backoff rules. For each user device of the plurality of user devices 302₁, ... 302_n, one of the plurality of backoff rules is assigned to

said user device. The plurality of backoff rules may e.g., be stored within a storage of a base station 300, and each backoff rule of the plurality of backoff rules may e.g., be stored within one of the plurality of user devices 302₁, ... 302_n to which said backoff rule is assigned. Or, the base station 300 may receive the plurality of backoff rules from the plurality of user devices 302₁, ... 302_n. Or, for each of the plurality of backoff rules, the base station 300 may transmit said backoff rule to one of the plurality of user devices 302₁, ... 302_n to which said backoff rule is assigned.

In an embodiment, the base station 300 may conduct scheduling depending on the plurality of backoff rules. For example, scheduling may, e.g., be conducted by the signal processor 300a of the base station 300.

According to an embodiment, for a user device 302₁ of the plurality of user devices 302₁, ..., 302_n, the base station 300 may estimate, depending on the backoff rule being assigned to the user device 302₁, a time period during which the user device 302₁ is not expected to transmit via the transmission channel, and the base station does not monitor whether or not the user device 302₁ transmits via the transmission channel during the time period. For example, the base station 300 may, e.g., determine the backoff counter value depending on the backoff rule and may estimate the time period during which it does not expect the user device 302₁ to transmit via the transmission channel from the determined backoff counter value.)

(E.g., before at least the time corresponding to the backoff counter value that has been drawn from the random number generator.)

In an embodiment, the base station 300 may determine a channel business at the user device depending on the plurality of backoff rules.

According to an embodiment, the base station 300 may determine the channel business by determining a channel business ratio CBR according to

$$CBR = (N_{tx} - N_{bo}) / N_{tx},$$

N_{tx} is a number of Listen-before-talk, LBT, slots from the beginning of a grant till an actual transmission. N_{bo} is the number of Listen-before-talk slots which was drawn by a pseudo random number generator as backoff.

Furthermore, a wireless communication system according to an embodiment is provided. The wireless communication system comprises one or more user devices, 302₁, ..., 302_n as described above and a base station 300 as described above.

5 In the following, embodiments of the present invention are described in more detail.

In embodiments, to overcome the issue of not knowing the backoff time while still fulfilling the required random backoff a pseudo random number generator (PRNG) with a seed which is known/derivable for both parties, is proposed. This way any transceiver in the network
10 can calculate the current backoff timer of any other UE, if it knows the seed being used.

The seed can either be signaled or derived from known user specific as well as global properties.

15 Embodiment-1: The PRNG algorithm as well as the information used to calculate the seed is preconfigured or configured to the UE.

For example, The PRNG algorithm may be a Gold sequence generator, such as in 36.211 or 38.211, Mersenne-Twister, xorshift generators, WELL generators, or any other pseudo
20 random number generator which is used for calculating the random backoff value.

The seed is also calculated based on a pre-configured or configured formula which includes information which is available to both sides, such as:

- 25
- User ID, UE-specific RNTI

 - Cell ID

 - Timing information, e.g. slot, subframe, frame number

30

In this way the gNB can calculate the current minimum random backoff values of all UEs in the network making better scheduling decisions, since it knows the earliest point in time when the UE will start.

35 Furthermore, the gNB does not have to monitor the channel for the transmission of that specific UE which saves power at the gNB side.

In a further embodiment, we propose to exploit the information on the difference of the calculated random backoff and the actual transmission time to derive information on the channel occupation at the UE side. Since the delay compared to the calculated random backoff is caused by a busy channel at the UE, the gNB implicitly knows the channel busy ratio (CBR) by the following relation:

$$\text{CBR} = (N_{\text{tx}} - N_{\text{bo}}) / N_{\text{tx}},$$

where N_{tx} is the number of LBT slots from the beginning of the grant till the actual transmission and N_{bo} is the number of LBT slots which was drawn by the PRNG as backoff.

For example, by scheduling 2 UEs that have a random backoff timer of 6 and 7 leads to minimal pauses between uplink transmissions as shown in Fig. 4.

Fig. 4 illustrates to user devices, UEs, having a random backoff timer and a base station according to an embodiment.

Alternatively, the RNG (random number generator) can be configured by the network during connection setup.

This can for example be done using RRC (radio resource control) signaling to initialize the RNG with a given seed.

Embodiments of the present invention have been described in detail above, and the respective embodiments and aspects may be implemented individually or two or more of the embodiments or aspects may be implemented in combination.

With regard to the above-described embodiments of the various aspects of the present invention, it is noted that they have been described in an environment in which a communication is between a transmitter, like a gNB or a UE, and a receiver, like a UE and a gNB. However, the invention is not limited to such a communication, rather, the above-described principles may equally be applied for a device-to-device communication, like a D2D, V2V, V2X communication. In such scenarios, the communication is over a sidelink between the respective devices. The transmitter is a first UE and the receiver is a second UE communicating using the sidelink resources.

In accordance with embodiments, the wireless communication system may include a terrestrial network, or a non-terrestrial network, or networks or segments of networks using as a receiver an airborne vehicle or a spaceborne vehicle, or a combination thereof.

5 In accordance with embodiments, a UE may comprise one or more of a mobile or stationary terminal, an IoT device, a ground-based vehicle, an aerial vehicle, a drone, a building, or any other item or device provided with network connectivity enabling the item/device to communicate using the wireless communication system, like a sensor or actuator, or a Wifi non-AP STA (AP = Access Point; STA = Station, user device in IEEE 802.11), e.g. 802.11ax
10 or 802.11be. In accordance with embodiments, a base station may comprise one or more of a macro cell base station, or a small cell base station, or a spaceborne vehicle, like a satellite or a space, or an airborne vehicle, like a unmanned aircraft system (UAS), e.g., a tethered UAS, a lighter than air UAS (LTA), a heavier than air UAS (HTA) and a high altitude UAS platforms (HAPs), or any transmission/reception point (TRP) enabling an item or a
15 device provided with network connectivity to communicate using the wireless communication system, or a Wifi AP STA, e.g. 802.11ax or 802.11be.

Although some aspects of the described concept have been described in the context of an apparatus, it is clear that these aspects also represent a description of the corresponding
20 method, where a block or a device corresponds to a method step or a feature of a method step. Analogously, aspects described in the context of a method step also represent a description of a corresponding block or item or feature of a corresponding apparatus.

Various elements and features of the present invention may be implemented in hardware
25 using analog and/or digital circuits, in software, through the execution of instructions by one or more general purpose or special-purpose processors, or as a combination of hardware and software. For example, embodiments of the present invention may be implemented in the environment of a computer system or another processing system.

30 Fig. 3 illustrates an example of a computer system 500. The units or modules as well as the steps of the methods performed by these units may execute on one or more computer systems 500. The computer system 500 includes one or more processors 502, like a special purpose or a general-purpose digital signal processor. The processor 502 is connected to a communication infrastructure 504, like a bus or a network. The computer system 500
35 includes a main memory 506, e.g., a random-access memory (RAM), and a secondary memory 508, e.g., a hard disk drive and/or a removable storage drive. The secondary memory 508 may allow computer programs or other instructions to be loaded into the computer system 500. The computer system 500 may further include a communications

interface 510 to allow software and data to be transferred between computer system 500 and external devices. The communication may be in the form of electronic, electromagnetic, optical, or other signals capable of being handled by a communications interface. The communication may use a wire or a cable, fiber optics, a phone line, a cellular phone link, an RF link and other communications channels 512.

The terms "computer program medium" and "computer readable medium" are used to generally refer to tangible storage media such as removable storage units or a hard disk installed in a hard disk drive. These computer program products are means for providing software to the computer system 500. The computer programs, also referred to as computer control logic, are stored in main memory 506 and/or secondary memory 508. Computer programs may also be received via the communications interface 510. The computer program, when executed, enables the computer system 500 to implement the present invention. In particular, the computer program, when executed, enables processor 502 to implement the processes of the present invention, such as any of the methods described herein. Accordingly, such a computer program may represent a controller of the computer system 500. Where the disclosure is implemented using software, the software may be stored in a computer program product and loaded into computer system 500 using a removable storage drive, an interface, like communications interface 510.

The implementation in hardware or in software may be performed using a digital storage medium, for example cloud storage, a floppy disk, a DVD, a Blue-Ray, a CD, a ROM, a PROM, an EPROM, an EEPROM or a FLASH memory, having electronically readable control signals stored thereon, which cooperate (or are capable of cooperating) with a programmable computer system such that the respective method is performed. Therefore, the digital storage medium may be computer readable.

Some embodiments according to the invention comprise a data carrier having electronically readable control signals, which are capable of cooperating with a programmable computer system, such that one of the methods described herein is performed.

Generally, embodiments of the present invention may be implemented as a computer program product with a program code, the program code being operative for performing one of the methods when the computer program product runs on a computer. The program code may for example be stored on a machine readable carrier.

Other embodiments comprise the computer program for performing one of the methods described herein, stored on a machine readable carrier. In other words, an embodiment of

the inventive method is, therefore, a computer program having a program code for performing one of the methods described herein, when the computer program runs on a computer.

- 5 A further embodiment of the inventive methods is, therefore, a data carrier (or a digital storage medium, or a computer-readable medium) comprising, recorded thereon, the computer program for performing one of the methods described herein. A further embodiment of the inventive method is, therefore, a data stream or a sequence of signals representing the computer program for performing one of the methods described herein.
- 10 The data stream or the sequence of signals may for example be configured to be transferred via a data communication connection, for example via the Internet. A further embodiment comprises a processing means, for example a computer, or a programmable logic device, configured to or adapted to perform one of the methods described herein. A further embodiment comprises a computer having installed thereon the computer program for
- 15 performing one of the methods described herein.

In some embodiments, a programmable logic device (for example a field programmable gate array) may be used to perform some or all of the functionalities of the methods described herein. In some embodiments, a field programmable gate array may cooperate

20 with a microprocessor in order to perform one of the methods described herein. Generally, the methods are preferably performed by any hardware apparatus.

The above described embodiments are merely illustrative for the principles of the present invention. It is understood that modifications and variations of the arrangements and the

25 details described herein are apparent to others skilled in the art. It is the intent, therefore, to be limited only by the scope of the impending patent claims and not by the specific details presented by way of description and explanation of the embodiments herein.

List of Acronyms and Symbols:

	RNG	Random Number Generator
	PRNG	Pseudo Random Number Generator
5	eNB	Evolved Node B (3G base station)
	LTE	Long-Term Evolution
	UE	User Equipment (User Terminal)
	RSU	Road Side Unit
	Uu	eNB-UE link
10	PC5	UE-UE link / Interface using Sidelink Channel for D2D communication
	D2D	Device-to-device
	IE	Information Element
	V2V	Vehicular-to-vehicular communications
	V2X	Vehicular-to-everything communications
15	HARQ	Hybrid Automatic Repeat Request
	NR-U	New Radio in unlicensed spectrum
	BS	Base Station
	gNB	Generation Node B (base station)
	RAN	Radio Access Network
20	FDM	Frequency Division Multiplexing
	RA	Resource Allocation
	SCI	Sidelink Control Information
	SL	Sidelink
	sTTI	Short(end) Transmission Time Interval
25	PUCCH	Physical Uplink Control Channel
	PDCCH	Physical Downlink Control Channel
	DMRS	Demodulation Reference Signal
	CBR	Channel Busy Ratio
	COT	Channel occupancy time
30	CWS	Contention Window Size
	RtoTx	Ready to Transmit
	RtoRx	Ready to Receive
	LBT	Listen-before-Talk
35	LBR	Listen-before-Receive

Claims:

1. A user device, UE, for a wireless communication system,
5 wherein
a backoff rule is stored within a storage of a base station and within a storage
of the user device; or
10 the user device is to transmit the backoff rule to the base station; or
the user device is to receive the backoff rule from the base station,
wherein, the user device is to determine a random backoff counter depending on the
15 backoff rule,
wherein the user device is to decrement the random backoff counter if a transmission
channel is not occupied for a certain duration,
20 wherein the user device is to transmit a data packet via the transmission channel, if
the random backoff counter reaches a predefined value.
2. The user device according to claim 1,
25 wherein the user device is to not change the random backoff counter while the
transmission channel is occupied.
3. The user device according to claim 1 or 2,
30 wherein the predefined value is zero.
4. The user device according to one of the preceding claims,
wherein the certain duration depends on a transmission priority for transmitting the
35 data packet.
5. The user device according to one of the preceding claims,

wherein the user device is to transmit the data packet via the transmission channel to the base station, if the random backoff counter reaches the predefined value.

6. The user device according to one of the preceding claims,

5

wherein the backoff rule comprises a pseudo random number generator algorithm,

wherein

10

the pseudo random number generator algorithm is stored within the storage of the base station and is stored within the storage of the user device; or

the user device is to transmit the pseudo random number generator algorithm or an algorithm indication indicating the pseudo random number generator algorithm to the base station; or

15

the user device is to receive the pseudo random number generator algorithm or the algorithm indication indicating the pseudo random number generator algorithm from the base station.

20

7. The user device according to claim 6,

wherein the pseudo random number generator algorithm is a Gold sequence generator algorithm, or

25

wherein the pseudo random number generator algorithm is a Mersenne-Twister algorithm, or

wherein the pseudo random number generator algorithm is a xorshift generator algorithm, or

30

wherein the pseudo random number generator algorithm is a WELL generator algorithm.

35

8. The user device according to claim 6 or 7,

wherein the backoff rule comprises a seed,

wherein

the seed is stored within the storage of the base station and is stored within the storage of the user device; or

5

the user device is to transmit the seed to the base station; or

the user device is to receive the seed from the base station.

10 9. The user device according to claim 8,

wherein the user device is preconfigured with the pseudo random number generator algorithm and/or with seed information, wherein the seed depends on the seed information.

15

10. The user device according to claim 8 or 9,

wherein the seed depends on information that is available at the user device and the base station, or on information that the user device is to transmit to the base station, or on information that the user device is to receive from the base station.

20

11. The user device according to one of claims 8 to 10,

wherein the seed depends on one or more of:

25

○ a user identifier, user ID, and/or a user device specific radio network temporary identifier, RNTI,

○ a cell identifier, cell ID ,

30

○ timing information, which, for example, depends on an OFDM symbol number and/or a slot number and/or a subframe number and/or a frame number,

35

○ the seed, wherein the user device is to receive the seed from the base station,

- the seed, wherein the seed is user-device-generated, and the user device is to transmit the seed to the base station.

12. The user device according to one of the preceding claims,

5

wherein the user device is to communicate over a sidelink or over a D2D interface, wherein, for example, the base station is another user device.

13. A base station, gNB, for a wireless communication system,

10

wherein

a backoff rule is stored within a storage of the base station and within a storage of a user device; or

15

the base station is to receive the backoff rule from the user device; or

the base station is to transmit the backoff rule to the user device,

20

wherein, the user device is to determine a random backoff counter depending on the backoff rule and is to start a transmission of a data packet via a transmission channel depending on the backoff counter and depending on whether or not the transmission channel is occupied.

25

14. The base station according to claim 13,

wherein the backoff rule comprises a pseudo random number generator algorithm,

wherein

30

the pseudo random number generator algorithm is stored within the storage of the base station and is stored within the storage of the user device; or

35

the base station is to receive the pseudo random number generator algorithm or an algorithm indication indicating the pseudo random number generator algorithm from the user device; or

the base station is to transmit the pseudo random number generator algorithm or the algorithm indication indicating the pseudo random number generator algorithm to the user device.

5 15. The base station according to claim 14,

wherein the pseudo random number generator algorithm is a Gold sequence generator algorithm, or

10 wherein the pseudo random number generator algorithm is a Mersenne-Twister algorithm, or

wherein the pseudo random number generator algorithm is a xorshift generator algorithm, or

15

wherein the pseudo random number generator algorithm is a WELL generator algorithm.

16. The base station according to claim 14 or 15,

20

wherein the backoff rule comprises a seed,

wherein

25 the seed is stored within the storage of the base station and is stored within the storage of the user device; or

the base station is to receive the seed from the base station; or

30 the base station is to transmit the seed to the user device.

17. The base station according to claim 16,

35

wherein the base station is preconfigured with the pseudo random number generator algorithm and/or with seed information, wherein the seed depends on the seed information.

18. The base station according to claim 16 or 17,

wherein the seed depends on information that is available at the user device and the base station, or on information that the base station is to transmit to the user device, or on information that the base station is to receive from the user device.

5

19. The base station according to one of claims 16 to 18,

wherein the seed depends on one or more of:

10

- a user identifier, user ID, and/or a user device specific radio network temporary identifier, RNTI,

- a cell identifier, cell ID ,

15

- timing information, which, for example, depends on an OFDM symbol number and/or a slot number and/or a subframe number and/or a frame number,

20

- the seed, wherein the user device is to receive the seed from the base station,

- the seed, wherein the seed is user-device-generated, and the user device is to transmit the seed to the base station.

25

20. The base station according to one of claims 13 to 19,

wherein the user device is one of a plurality of user devices,

wherein the backoff rule is one of a plurality of backoff rules,

30

wherein for each user device of the plurality of user devices, one of the plurality of backoff rules is assigned to said user device,

wherein

35

the plurality of backoff rules is stored within a storage of a base station, and each backoff rule of the plurality of backoff rules is stored within one of the plurality of user devices to which said backoff rule is assigned; or

the base station is to receive the plurality of backoff rules from the plurality of user devices; or

5 wherein for each of the plurality of backoff rules, the base station is to transmit said backoff rule to one of the plurality of user devices to which said backoff rule is assigned.

21. The base station according to claim 20,

10

wherein the base station is to conduct scheduling depending on the plurality of backoff rules.

22. The base station according to claim 20 or 21,

15

wherein, for a user device of the plurality of user devices, the base station is to estimate, depending on the backoff rule being assigned to the user device, a time period during which the user device is not expected to transmit via the transmission channel, and

20

wherein the base station is to not monitor whether or not the user device transmits via the transmission channel during the time period.

23. The base station according to one of claims 20 to 22,

25

wherein the base station is to determine a channel business at the user device depending on the plurality of backoff rules.

24. The base station according to claim 23,

30

wherein the base station is to determine the channel business by determining a channel business ratio CBR according to

$$\text{CBR} = (\text{N_tx} - \text{N_bo}) / \text{N_tx},$$

35

wherein N_tx is a number of Listen-before-talk, LBT, slots from the beginning of a grant till an actual transmission, and

wherein N_{bo} is the number of Listen-before-talk slots which was drawn by a pseudo random number generator as backoff.

25. A wireless communication system, comprising:

5

one or more user devices, wherein each of the one or more user devices is a user device according to one of claims 1 to 12, and

a base station according to one of claims 13 to 24.

10

26. A method for operating a wireless communication system, wherein the method comprises:

15

Storing a backoff rule within a storage of a base station and within a storage of a user device; or transmitting the backoff rule from the user device to the base station; or receiving the backoff rule at the user device from the base station,

determining, by the user device, a random backoff counter depending on the backoff rule,

20

decrementing, by the user device, the random backoff counter if a transmission channel is not occupied for a certain duration,

transmitting, by the user device, a data packet via the transmission channel, if the random backoff counter reaches a predefined value.

25

27. A method for operating a wireless communication system, wherein the method comprises:

30

Storing a backoff rule within a storage of a base station and storing the backoff rule within a storage of a user device; or receiving the backoff rule from the user device at the base station; or transmitting the backoff rule from the base station to the user device,

35

wherein, the user device determines a random backoff counter depending on the backoff rule and starts a transmission of a data packet via a transmission channel depending on the backoff counter and depending on whether or not the transmission channel is occupied.

28. A computer program product comprising instructions which, when the program is executed by a computer, causes the computer to carry out one or more methods in accordance with claim 26 or 27.

5

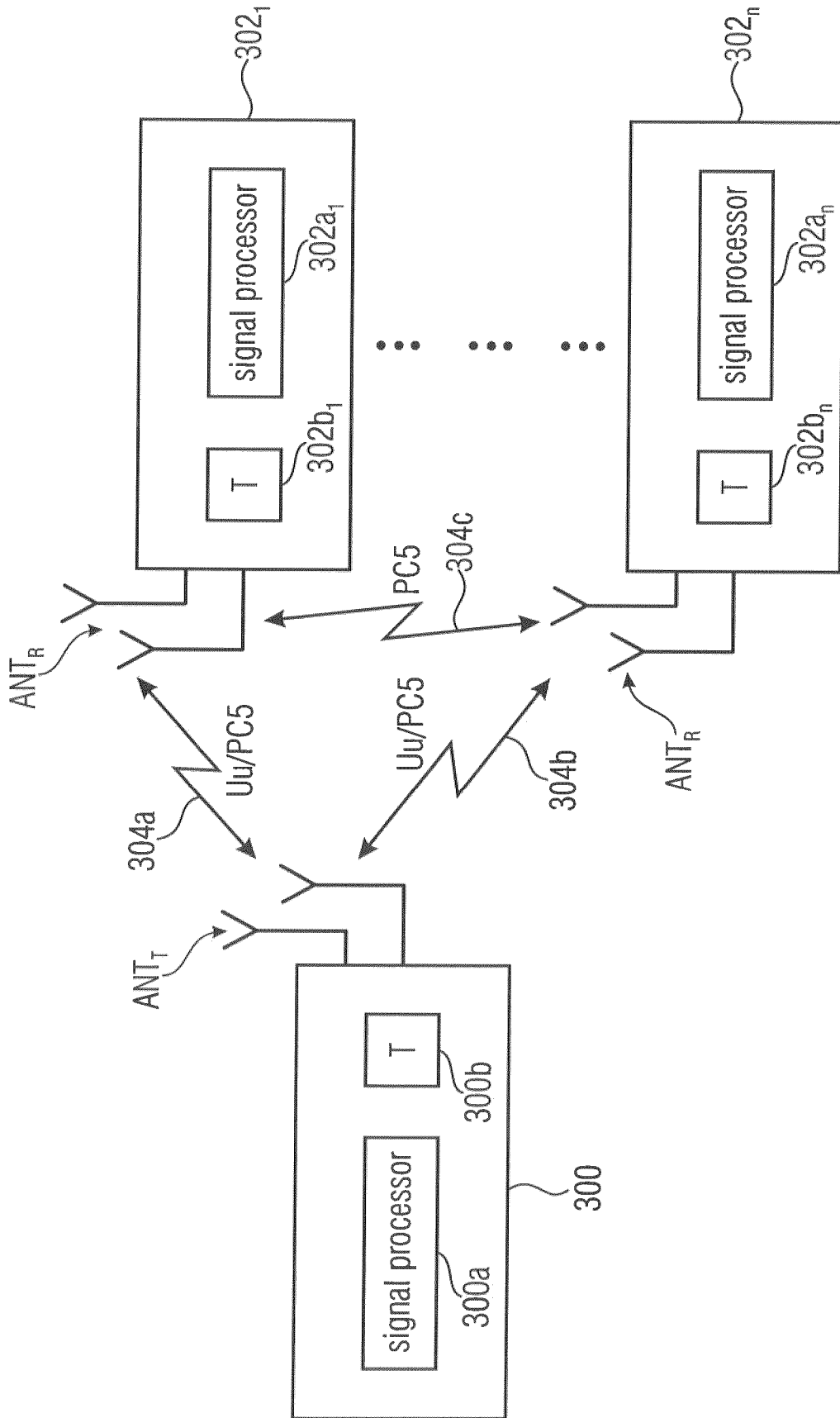

Fig. 2

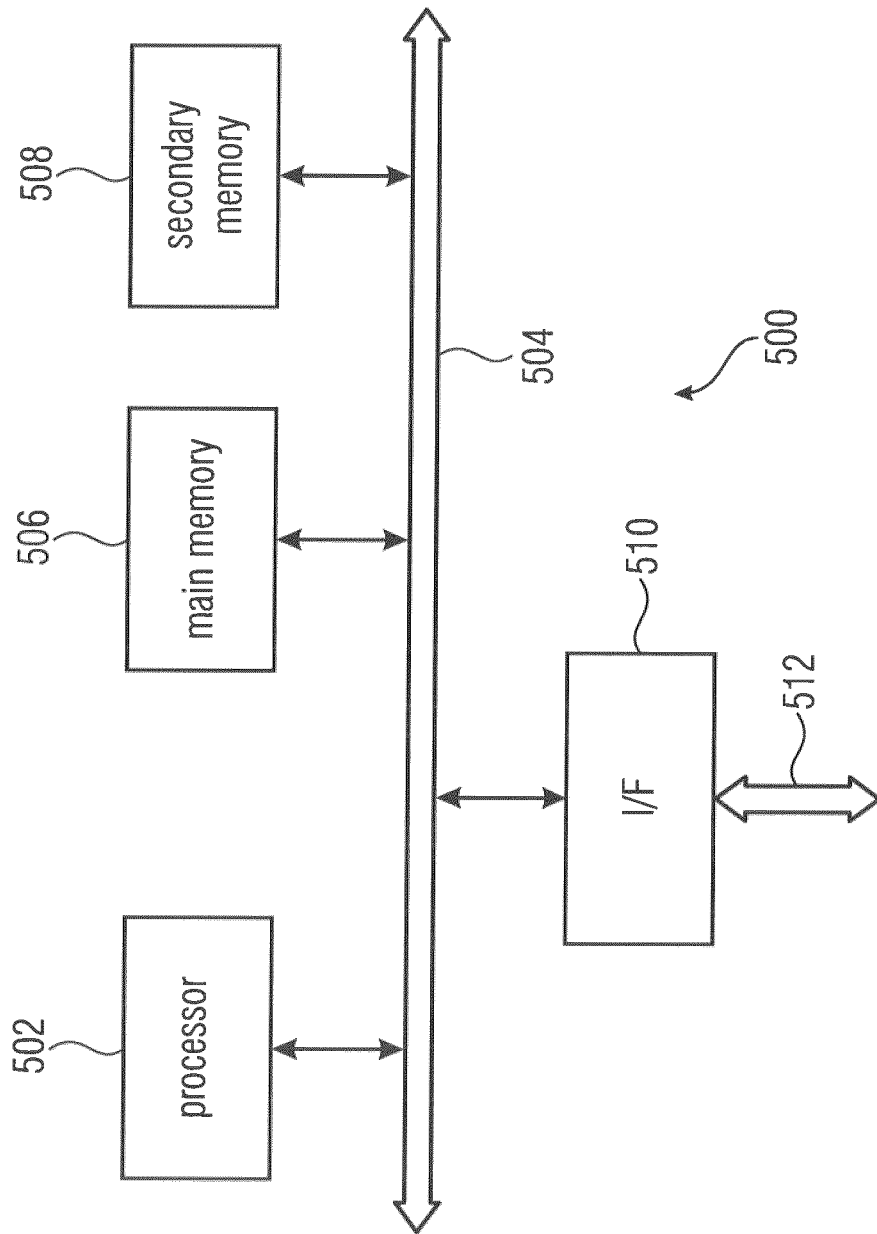

Fig. 3

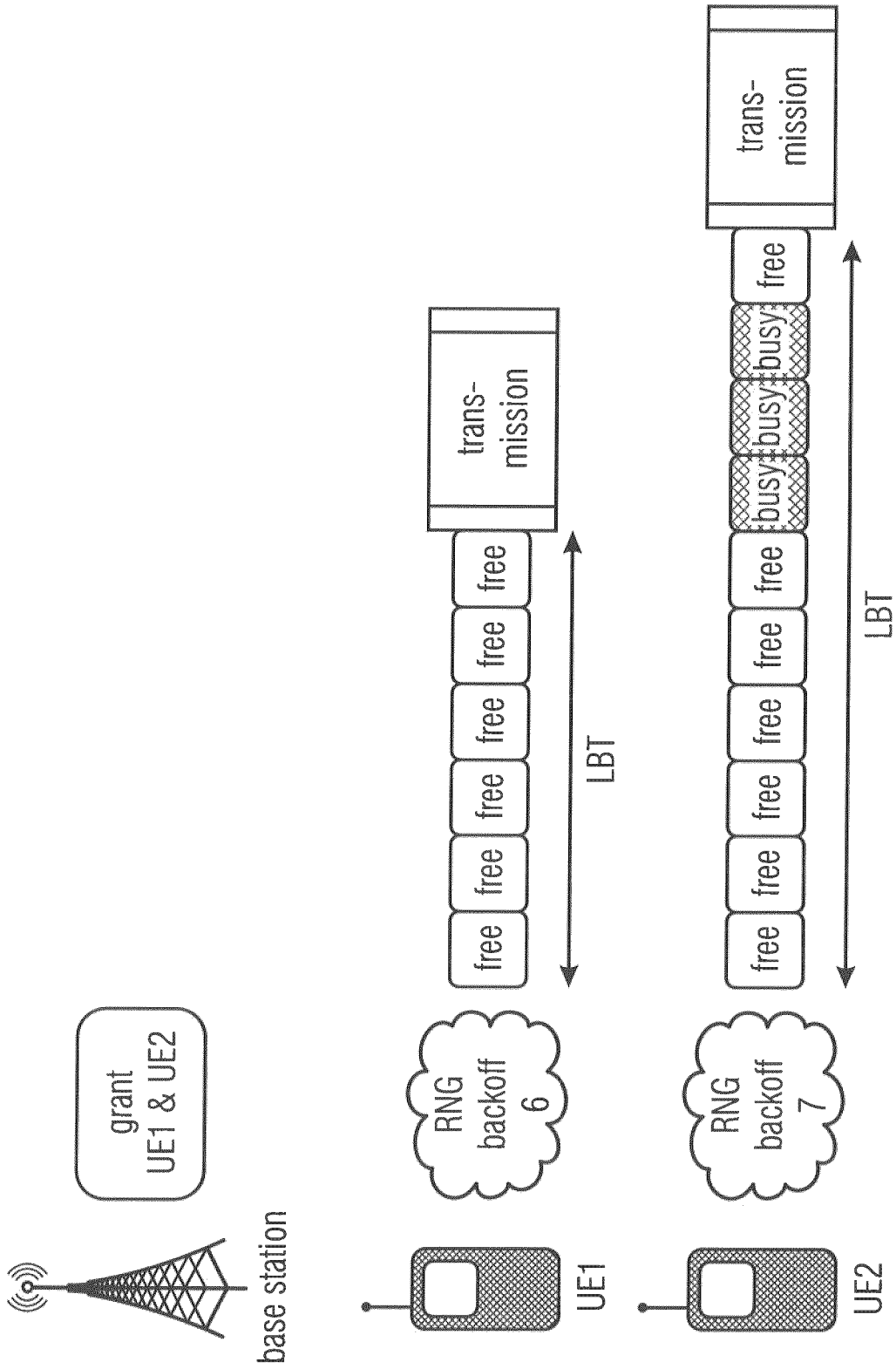

Fig. 4

INTERNATIONAL SEARCH REPORT

International application No
PCT/EP2020/072799

A. CLASSIFICATION OF SUBJECT MATTER
INV. H04W74/00 H04W74/08
ADD.
According to International Patent Classification (IPC) or to both national classification and IPC

B. FIELDS SEARCHED
Minimum documentation searched (classification system followed by classification symbols)
H04W
Documentation searched other than minimum documentation to the extent that such documents are included in the fields searched

Electronic data base consulted during the international search (name of data base and, where practicable, search terms used)
EPO-Internal

C. DOCUMENTS CONSIDERED TO BE RELEVANT		
Category*	Citation of document, with indication, where appropriate, of the relevant passages	Relevant to claim No.
X	EP 3 410 812 A1 (LG ELECTRONICS INC [KR]) 5 December 2018 (2018-12-05) paragraphs [0011], [0019], [0030], [0073], [0080] - [0082], [0109], [0118], [0126], [0131] - [0132], [0170]; figures 9b, 15 -----	1-28
A	US 2017/223740 A1 (MALLIK SIDDHARTHA [US] ET AL) 3 August 2017 (2017-08-03) paragraph [0058] - paragraph [0065]; figures 3, 4, 13 -----	24
A	WO 2017/026937 A1 (ERICSSON TELEFON AB L M [SE]) 16 February 2017 (2017-02-16) claim 1; figures 6,10 -----	1,13, 25-28

Further documents are listed in the continuation of Box C.

See patent family annex.

* Special categories of cited documents :

- "A" document defining the general state of the art which is not considered to be of particular relevance
- "E" earlier application or patent but published on or after the international filing date
- "L" document which may throw doubts on priority claim(s) or which is cited to establish the publication date of another citation or other special reason (as specified)
- "O" document referring to an oral disclosure, use, exhibition or other means
- "P" document published prior to the international filing date but later than the priority date claimed

- "T" later document published after the international filing date or priority date and not in conflict with the application but cited to understand the principle or theory underlying the invention
- "X" document of particular relevance; the claimed invention cannot be considered novel or cannot be considered to involve an inventive step when the document is taken alone
- "Y" document of particular relevance; the claimed invention cannot be considered to involve an inventive step when the document is combined with one or more other such documents, such combination being obvious to a person skilled in the art
- "&" document member of the same patent family

Date of the actual completion of the international search

16 September 2020

Date of mailing of the international search report

29/09/2020

Name and mailing address of the ISA/
European Patent Office, P.B. 5818 Patentlaan 2
NL - 2280 HV Rijswijk
Tel. (+31-70) 340-2040,
Fax: (+31-70) 340-3016

Authorized officer

Palencia Gutiérrez

INTERNATIONAL SEARCH REPORT

Information on patent family members

International application No PCT/EP2020/072799

Patent document cited in search report	Publication date	Patent family member(s)	Publication date
EP 3410812	A1	05-12-2018	EP 3410812 A1 05-12-2018
			US 2019014594 A1 10-01-2019
			WO 2017131478 A1 03-08-2017

US 2017223740	A1	03-08-2017	CN 108605361 A 28-09-2018
			EP 3412101 A1 12-12-2018
			US 2017223740 A1 03-08-2017
			WO 2017136167 A1 10-08-2017

WO 2017026937	A1	16-02-2017	AR 105690 A1 01-11-2017
			CN 107926053 A 17-04-2018
			EP 3335512 A1 20-06-2018
			JP 6606596 B2 13-11-2019
			JP 2018531534 A 25-10-2018
			KR 20180038004 A 13-04-2018
			US 2017188387 A1 29-06-2017
			WO 2017026937 A1 16-02-2017
