

J. PHILLIPS.
 STEAM ENGINE VALVE GEAR.
 APPLICATION FILED JUNE 5, 1909.

979,031.

Patented Dec. 20, 1910.

3 SHEETS—SHEET 1.

FIG 1

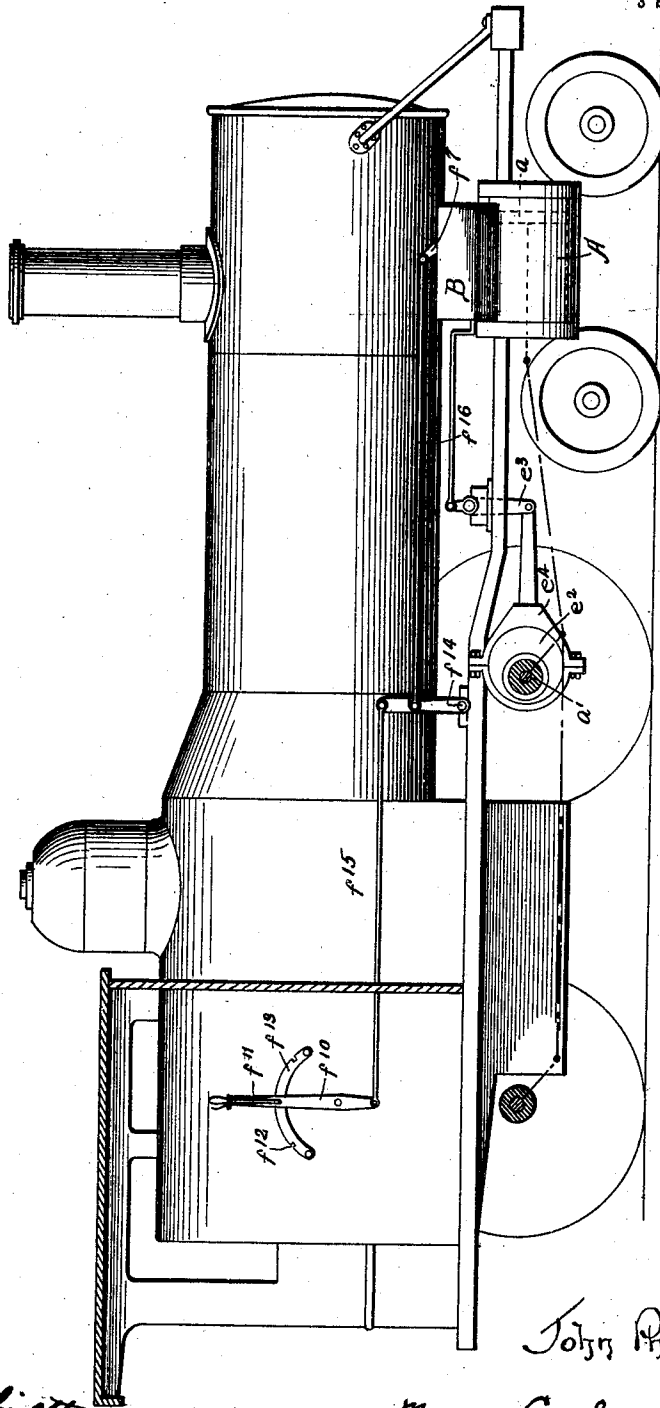

Witnesses

H. G. Bobiette
Horace E. Deitz

Inventor

John Phillips.

Meyers, Cushman & Lea

Attorneys

J. PHILLIPS.
 STEAM ENGINE VALVE GEAR.
 APPLICATION FILED JUNE 6, 1909.

979,031.

Patented Dec. 20, 1910.

3 SHEETS—SHEET 2.

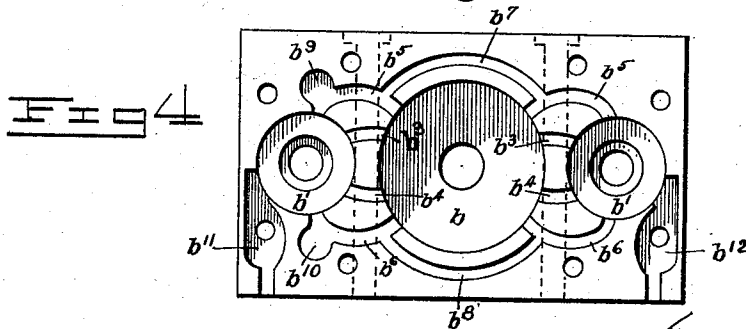
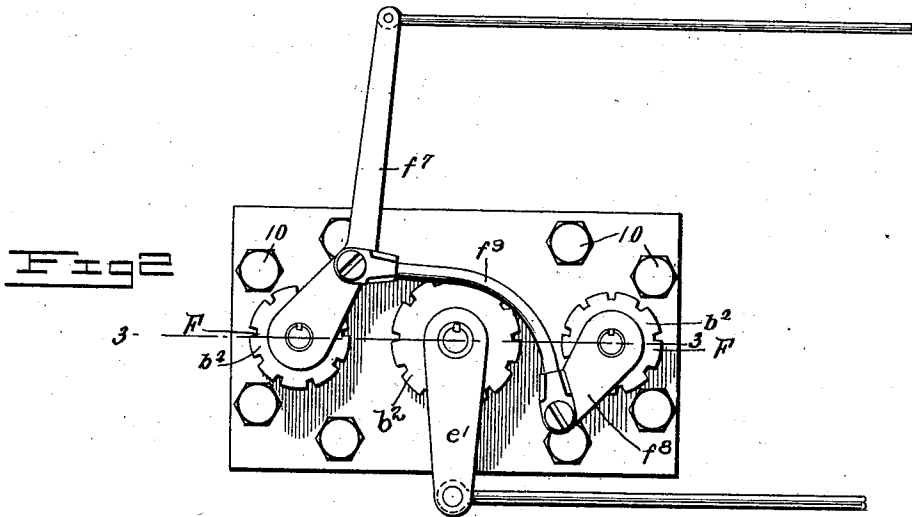
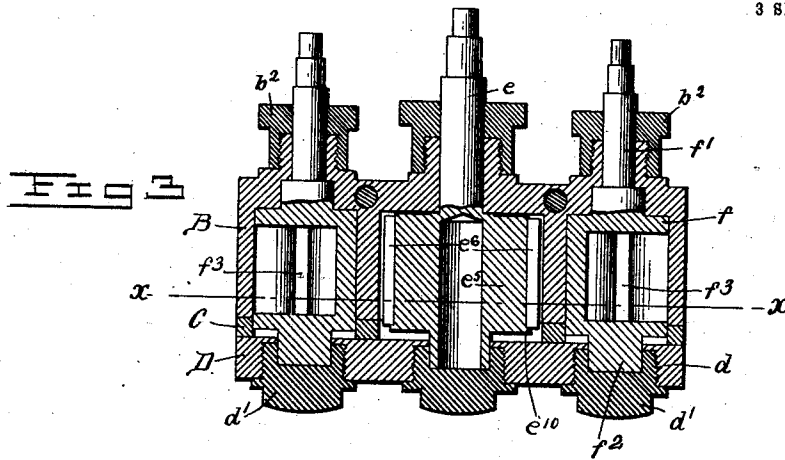

Inventor
 John Phillips-

By Meyers, Cushman & Co.

His Attorneys

Witnesses
 H. A. Bolinette
 Horace G. Deitz

J. PHILLIPS.
 STEAM ENGINE VALVE GEAR.
 APPLICATION FILED JUNE 5, 1909.

979,031.

Patented Dec. 20, 1910.

3 SHEETS—SHEET 3.

Fig 6

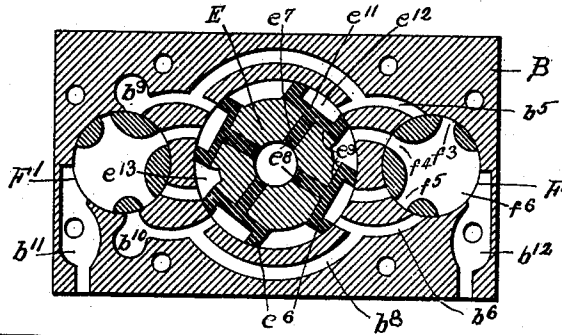

Fig 7

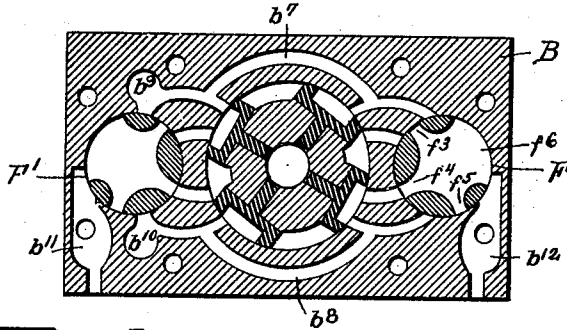

Fig 8

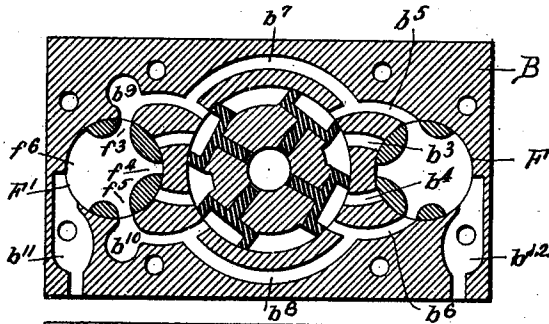
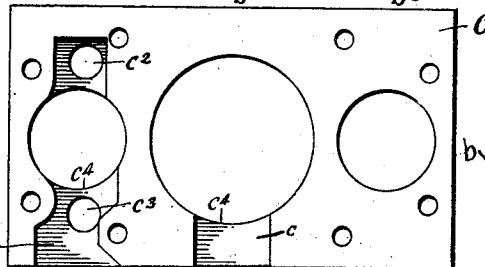

Fig 9



Witnesses
H. G. Rivette

Horace C. Deitz

Inventor
John Phillips.

by *Mayer, Cushman & Co.*

his Attorneys

UNITED STATES PATENT OFFICE.

JOHN PHILLIPS, OF WILKESON, WASHINGTON.

STEAM-ENGINE VALVE-GEAR.

979,031.

Specification of Letters Patent.

Patented Dec. 20, 1910.

Application filed June 5, 1909. Serial No. 500,418.

To all whom it may concern:

Be it known that I, JOHN PHILLIPS, a citizen of the United States, residing at Wilkeson, in the county of Pierce and State of Washington, have invented new and useful Improvements in Steam-Engine Valve-Gear, of which the following is a specification.

My invention relates to improvements in valve gear and is especially applicable for use in connection with steam engines such as locomotives wherein a reversing mechanism is employed in connection with an automatic cut-off for controlling the movements of the piston.

Among the objects of my invention are to be found the following: (1) The provision of a valve gear in which a single automatic cut-off or distributing valve is employed for controlling the admission and exhaust of steam during the running of the engine, and two separate controlling valves for controlling the stopping and starting of the engine and the direction of its rotation. (2) The provision of controlling mechanism by means of which the direction of movement of the engine and the stopping and starting thereof may be controlled by a single lever. (3) The provision of a valve chest and valves arranged in such manner that movements of the piston will cause a movement of exhaust steam therethrough for the purpose of preventing cooling of the valve chest and condensation of steam. (4) The provision of a single cut-off valve operated by the eccentric of the locomotive for controlling the admission and exhaust of steam to the cylinder irrespective of the direction of movement of the locomotive. (5) The elimination of the "link motion" in locomotives. (6) To provide a valve gear which is simple and efficient in operation, durable in construction, which can be readily placed in position, and which is of relatively low cost of manufacture.

To these and other ends, the nature of which will be readily understood as the invention is hereinafter disclosed, said invention consists in the improved construction and combination of parts hereinafter fully described, illustrated in the accompanying drawings, and particularly pointed out in the appended claims.

In the accompanying drawings, in which similar reference characters indicate similar parts in each of the views,—Figure 1 is a diagrammatic view of a locomotive showing

my improved valve gear in position thereon, and the means for manipulating the valves therein. Fig. 2 is a rear elevation of the gear casing and showing the arrangement of levers for operating the several valves. Fig. 3 is a sectional view taken on the line 3, 3, of Fig. 2. Fig. 4 is a face view of the valve carrying portion of the gear casing, the valves being omitted. Fig. 5 is a face view of the intermediate portion of the casing containing the steam inlet and exhaust outlet for the valve mechanism. Figs. 6, 7 and 8 are sectional views taken on the line x, x , of Fig. 3, said views showing the throttle and reverse valves in different positions, the automatic cut-off or distributing valve being shown in full lines in similar position in each of the views.

For the purpose of showing one way in which my invention may be placed into practical use, I have shown it as applied to a locomotive, one of the cylinders of which, designated as A, is shown as provided with a casing forming the casing for the valve gear or mechanism described hereinafter. The cylinder A is provided with the usual piston a connected in the usual manner with one of the driving axles a' of the locomotive, the structure being of any preferred type and providing a reciprocating movement of the piston within the cylinder. It is to be understood of course that the opposite ends of the cylinder will be provided with ports communicating with the valve casing, said ports providing for the admission of steam to opposite sides of the piston, said ports also serving as exhaust ports as hereinafter described. The remaining operating members shown in Fig. 1 of the drawings will be described in detail in connection with the parts to which they respectively relate.

The valve casing is preferably formed of three members B, C and D, the member B carrying the valves and the passage-ways or ports connecting the valves with each other and with the cylinder; the member C carries the steam inlet and exhaust ports, while the member D carries the bearings for one end of each of the valves, said member also forming a closure for the valve casing. While I have shown the casing as formed in three members, it will be understood that the division of the casing may be in a different manner, forming it of a greater or less number of members, but the

particular arrangement shown and described is preferred by reason of the fact that the construction is one capable of being produced at a minimum amount of expense.

5 The member B is preferably of rectangular outline, and is of relatively greater thickness than the members C and D, as shown in Fig. 3 of the drawings. As shown in Fig. 4, the member B is provided with a
10 central bore b and a smaller bore b' on each side of the bore b , said bores being of a depth less than the thickness of the member, thereby providing a wall at the rear of the casing, said wall being provided with open-
15 ings arranged centrally of the bores and forming bearings for the valves presently described. The bearings for the valves may be formed integral with or separate from said walls, as may be found most conven-
20 ient, the bearings and valves, however, being complementally formed to provide a steam-tight connection at these points. As shown in Figs. 2 and 3, the bearings for the valves are provided with removable packing glands
25 b^2 to aid in providing the steam-tight connection.

Referring more particularly to Fig. 4, a description of the various passage-ways and by-passes will now be made. Each of the
30 bores b' is connected to the central bore b by two substantially parallel passage-ways or ports b^3, b^4 , which form direct channels of communication between said bores, the ports or passage-ways b^3 being shown as the
35 upper ones in said figure, while the passage-ways b^4 are shown as the lower ones therein. Additional to said passage-ways I connect the central bore with each of the smaller bores by means of by-passes b^5, b^6 , the former
40 being located above the passage-ways b^3 , while the latter are shown as located below the passage-ways b^4 in said figure. This construction provides for communication between the central bore and each smaller
45 bore at four different points, two being located above and two located below a line which extends horizontally through the axis of the several bores, this division above and below such line forming an essential feature
50 of the operation of the mechanism as presently described. The by-passes are also connected together by passage-ways b^7, b^8 , said passage-ways being shown as arranged concentric with the central bore, the passage-
55 way b^7 connecting the two by-passes b^5 , while the passage-way b^8 connects the by-passes b^6 , this construction providing for communication between one of the bores b' and either one of two exhaust openings b^9, b^{10} , located adjacent to and communicating with the by-passes of the opposite bore b' , the exhaust opening b^9 being in connection
60 with by-pass b^5 , while the opening b^{10} is in connection with the by-pass b^6 . Each of the smaller bores b' is connected with the cylin-

der of the engine by means of a passage-way, the passage-way for the bores shown at the left of Fig. 4 being indicated as b^{11} , while that for the bore on the right is designated as b^{12} . These passage-ways provide for the
70 admission of steam at opposite ends of the cylinder, and also serve as passages for the exhaust steam from the cylinder, said passage-ways being connected to proper points in the cylinder in a usual or preferred
75 manner.

The several ports and passage-ways described have a depth slightly less than that of the central bore b , each of said passage-ways and by-passes, however, together with
80 the several bores, extending from one face (the front face shown in Fig. 4) of the member B, said face being flat and extending on a single plane. The passage-ways and by-passes have their front portions
85 closed by the plate forming the member C, said member having its rear face flat and fitting the front face of member B in a manner to provide a steam-tight connection between said members when the casing is
90 assembled.

The member C is provided with openings corresponding in position and diameter to the bores shown in the member B, said open-
95 ings extending entirely through said member C and providing an elongation of the several bores. As shown in Fig. 5, the front face of the member C is formed with a recessed portion c which leads from the opening of the bore b to the edge of the member,
100 said recessed portion forming the steam inlet to said bore, said inlet being of suitable size and connected to a steam delivering port (not shown), in any suitable manner. The inlet port c is shown as extending down-
105 wardly from the bore, but it will be understood that, if desired, it may be located on the opposite or upper side of said bore. Said member C is also provided with a recessed portion c' which intersects the open-
110 ing for the bore b' shown at the left in Fig. 4, said recessed portion being extended to an extent sufficient to include therein openings c^2 and c^3 , which are in alinement with the openings b^9 and b^{10} respectively of the member B, the openings c^2 and c^3 forming
115 channels of communication between their respective exhaust openings and the recessed portion c' , which latter forms the exhaust passage-way for the steam which has been received from the cylinder, said exhaust
120 passage-way leading to the edge of said member and being open to the atmosphere at this point or to a passage-way for the exhaust steam if the latter is to be passed
125 to the atmosphere at any other particular point. The recessed portions c and c' are of less depth than the thickness of the member C, thereby providing a wall c^4 interme-
130 diate said portions and the member B.

The member D completes the casing and is adapted to fit over the front face of member C, said member D having screw-threaded openings d axially aligned with the several bores, said openings being adapted to receive removable bearing members d' preferably having their inner ends recessed to receive the ends of the valves presently described, said members d' forming the bearings for one end of the valves.

The members B, C, and D, are connected together by suitable bolts or screws 10, extending through each of the members, said bolts or screws tightening the members together to form a substantially unitary structure. If necessary, suitable packing may be interposed between the members, although it will be understood that by reason of the flat opposing faces of the members, the use of packing may be generally dispensed with, the material of which the members are formed providing for a sufficiently tight joint without requiring the use of packing. The casing is secured to the cylinder by means of bolts or other securing means which pass vertically through the members B and D, as shown in Fig. 3, thereby removably securing the entire structure to the cylinder as a unitary structure.

E designates the automatic cut-off or distributing valve which serves to admit and cut-off the steam to the cylinder to provide movements of the piston. Said valve comprises a spindle e of a length to extend from its bearing d' to and through its bearing carried by the member B, and its gland b^2 , the outer end of said spindle being provided with a projecting portion adapted to receive an arm e' , the free end of which is connected, through suitable connections with an eccentric e^2 carried by the drive shaft of the engine, the connections being of any preferred arrangement, those shown in the drawings consisting of a rocking lever e^3 , the opposite ends of which are connected respectively to the arm e' and the eccentric ring e^4 . By this construction, the movements of the rocking lever e^3 provided by the eccentric e^2 will be communicated to the arm e' and provide a limited oscillatory movement to said spindle e . The arm e' is connected to said shaft in any suitable manner, as by a spline, and may be secured in position against movement longitudinally of the spindle by any suitable means, such as a nut.

As shown in Fig. 3, the spindle has its forward portion in the form of a tube, the end of said tubular portion being seated within its bearing d' . Intermediate the ends of the spindle, the latter is enlarged, as at e^5 , to provide a carrier for a plurality of valve members e^6 . The enlarged portion e^5 is of a length slightly less than the combined depth of the bore b and its opening in the member C, one end of said portion being adapted to

contact with the inner end of the bore, being held in that position by the bearing member d' of its spindle, as shown in Fig. 3. Said enlarged portion is provided with radial openings e^7 spaced approximately equidistant around the periphery of said portion, said openings being of a length less than the length of the portion, and forming receptacles for shanks e^8 of the valve members e^6 , said openings leading into the recessed portion of the spindle. As shown in the drawings, I preferably employ four valve members e^6 , said valve members having their shanks extending radially at angles of approximately ninety degrees from each other, thereby placing the openings for opposing members in approximate diametrical alignment.

The enlarged portion e^5 is of less diameter than the diameter of the bore b , and its periphery is provided with flattened surfaces e^9 which extend at approximately right angles to the direction of depth of the openings e^7 , said flattened surfaces being of less length than the length of the portion e^5 , and terminating with projecting flanges e^{10} , each flattened surface being of a width sufficient to extend on opposite sides of its opening e^7 .

The valve members e^6 each comprise the shank e^8 and a valve face portion e^{11} , the latter having its outer face curved to correspond with the curvature of the bore b , said portion e^{11} being of a length and width approximating the width of the flattened surfaces e^9 with which the inner face of said portion e^{11} is normally in contact. The outer face of said portion e^{11} is formed with a recess e^{12} having a length less than the length of said face, the length of said recess e^{12} being approximately that of the depth of the passage-ways and by-passes formed in the member B, the width of said recess approximately corresponding to the distance between the outer walls of the pairs of steam passage-ways formed in the member B, viz., the passage-way b^3 and by-pass b^5 or passage-way b^4 and by-pass b^6 , said recess being intended to form a bridge between said pairs of passage-ways, the recess being of sufficient depth to provide for the maximum amount of steam passing therethrough. It is to be noted at this point that said recesses act only in connection with exhaust steam, the operation of the mechanism at no time providing for the use of said recesses in connection with live steam.

On diametrically opposite sides of the portion e^5 and intermediate two adjacent members e^6 the portion e^5 is longitudinally recessed, as at e^{13} , said recesses extending throughout the length of the portion, and being open at the steam inlet end of the bore to provide for the delivery of steam into the bore in position to pass into either of the passage-ways b^3 , b^4 , said recesses, however,

being of insufficient breadth to permit of a delivery of steam to both of said passage-ways at the same time, the oscillations of the valve alternately opening and closing said passage-ways, and inasmuch as said recesses e^{13} are diametrically opposite each other, it will be understood that when the recess e^{13} on one side of the valve opens passage-way b^4 as an example, the diametrically opposite recess e^{13} will open the passage-way b^3 on the opposite side of the bore, the members e^6 serving to cut off the other passage-ways when in this position. These positions are directly reversed when the valve is oscillated to its opposite position.

F designates the throttle and reversing valve, two of which are employed in the mechanism, one being located in each of the bores b' . The valves F are of similar configuration; therefore, a description of the details of but one of these valves will be given. The valve F comprises a body portion f , a spindle f' therefor extending axially from one end of the body portion, and a bearing f^2 extending from the opposite end of said portion, said bearing f^2 being adapted to be seated within its bearing member d' . The body portion is slightly tapered from its bearing to its spindle end, the bores b' being correspondingly tapered, this construction being provided to enable the formation of a tight steam joint between the member B and the valve, and to take up wear.

The body portion f is provided with four radially extending openings or passage-ways $f^3, f^4, f^5,$ and f^6 , each of said openings leading from a central cut-out portion of the body portion, the openings or ports or passage-ways $f^3, f^4, f^5,$ being of substantially equal width and length, and spaced apart substantially equal distances on the periphery of the body portion, the distance between the ports f^3 and f^5 being equal to the distance between the by-passes b^5 and b^6 at their ends leading into the bore b' , said ports f^3 and f^5 being adapted, when the valve is in one position, to register with said by-passes. The port f^4 is located substantially mid-way between ports f^3 and f^5 , and in the position of the valve referred to, said port f^4 is closed by the wall located between the passage-ways b^3 and b^4 , this position of the parts being shown in Fig. 8 of the drawings. The opening or port f^6 is of a greater width than either of the remaining ports of the valve, and is located substantially diametrically opposite the port f^4 , said opening being of sufficient width to maintain open communication with the exhaust openings b^{11} or b^{12} dependent upon the bore in which the valve is located, during the pivotal movements of the valve to provide the several changes in direction of steam movements hereinafter indicated. The several

openings or ports of the body portion are of a length corresponding approximately to the depth of the various ports and passage-ways of the member B.

For the purpose of distinguishing the two valves in the description of the operation herein, I have designated the valve located in the bore at the right of Figs. 6, 7 and 8, as F, and the valve located in the bore at the left of said figures as F'.

The spindle f' of the valves extends through its packing gland b^2 , projecting beyond said gland and being provided with an operating arm or lever, the latter being connected to the spindle in any suitable manner, such as by a spline connection. The arrangement of levers for providing the movements of the valves are indicated in Fig. 2 of the drawings, in which the lever f^7 is shown as secured to the spindle of valve F, and an arm or lever f^8 is secured to the spindle of valves f' , the lever f^7 being of greater length than the lever f^8 , said levers being connected together by means of a curved arm f^9 which is shaped to permit movements of the levers without contacting with any portion or affecting the movements of the arm e' . As will be seen, the connection f^9 is pivoted to the lever f^7 at a point above the plane of a line passing through the axis of the spindle f' while the opposite end of said connection is pivotally connected to the arm f^8 below such line, this particular form of connecting the parts providing for movements of the valves in opposite directions, as will be seen by the arrows in said Fig. 2, this opposite direction of movement being provided because of the fact that in the particular arrangement of the ports in the member B, the openings or ports f^6 are both located on the outer sides of the bores, viz., at the point of greatest distance from the axis of the valve E.

For the purpose of imparting movements to the valve F, I mount in the engineer's cab of the locomotive an operating lever f^{10} having a latch bar f^{11} adapted to coact with any one of a plurality of notches f^{12} carried by a segment f^{13} , this particular construction being simply conventional, it being obvious that any other form of selective locking device may be used instead of that described, it being understood that the lever f^{10} may be locked in any one of at least three positions. The lever f^{10} is connected with lever f^7 in any suitable manner, that shown in the drawings being simply a rock shaft f^{14} carrying arms to the free ends of which are secured connections f^{15} and f^{16} , the arrangement being such that a pivotal movement of the lever f^{10} will provide a movement of the lever f^7 and produce resultant movements of the valves F and F'.

When the mechanism is employed in connection with locomotives, the valve mecha-

nism herein described, with the exception of the mechanism for operating the lever f^7 , is duplicated on opposite sides of the locomotive, the parts, however, being set in advance on one side in order to provide for overcoming dead centers as is usual in locomotive construction. To provide for the movements of the throttle and reversing valves F and F' on the opposite sides, the shaft f^{14} may be carried across the locomotive and have its opposite ends provided with the lever and connections f^{10} , thereby providing simultaneous movements of the valves by the movement of a single lever f^{10} .

As heretofore indicated, the admission of steam to the valve casing is through the port e ; and as heretofore pointed out, and as will be seen by reference to Fig. 3, the forward end of the enlarged portion e^5 is spaced from the inner face of the bearing D, which forms the closure for the forward end of the steam cavity, thereby providing a steam space annular with respect to the bearing end of the spindle e . This steam space is open to the recesses formed between the valve members e^6 , but in view of the fact that but two of the four recesses shown (the recesses e^{13}) have a position during the oscillations of the valve E where communication is provided with the several passage-ways of the member B, it will be understood that the live steam is at all times present within said recesses e^{13} and the annular space formed at the forward end of the enlarged portion e^5 ; said recesses and said space may be considered as a part of the steam passage-way leading from the boilers or steam supply to the engine, said recesses and space being in open communication with the source of steam supply. By reason of the fact that the valve members e^6 are closed both to the recesses and to said annular space, it will be understood that live steam cannot pass into the recesses e^{12} formed in the valve members e^6 .

In describing the operation of the valve mechanism herein set forth, the same will be given with respect to its use on a locomotive, although it will be understood that when applied to a stationary engine substantially the same operation will result, the mechanism being especially adapted for use in connection with locomotive engines. It is to be noted that the automatic cut-off or distributing valve E is continuously operated during movements of the drive wheels through the eccentric e^2 , this valve having the limited oscillating movement heretofore referred to; the throttle and reversing valves F and F' however, are manually operated and retain a predetermined position, until such position is changed by a movement of the lever f^{10} .

Assuming the various parts of the mechanism to be in the position shown in Fig. 8,

which is the position of the throttle and reversing valves when the locomotive is at rest, the operation of the parts will be described successively in moving the locomotive in one direction, stopping it and then moving it in the opposite direction, and stopping it in position to leave the parts substantially as shown in Fig. 8.

By referring to Fig. 8, it will be seen that the valves F and F' are arranged with their ports b^3 and b^4 of the member B, thereby closing said valves F and F' against the entrance of live steam from the valve E, the latter as heretofore pointed out having its recesses e^{13} filled with live steam. At the same time, the ports f^3 and f^5 are in registration with the passage-ways b^5 and b^6 respectively, with the result that open communication is provided between both sides of the piston and the exhaust ports b^9 and b^{10} , this position of the valve permitting the engine to run free under its momentum when the steam is cut off, such movement of the locomotive permitting the piston to drive out the exhaust steam through these channels, and retaining the casing and its members against cooling, this movement being continued until the locomotive comes to rest. In this position, the lever f^{10} is located as shown in Fig. 1 of the drawings, at an intermediate point of its path of movement. When it is desired to start movement of the locomotive, the lever f^{10} is moved to one extreme of its length of movement, the movement of said lever causing the valves F and F' to be shifted, the direction of shifting movement depending upon the direction of movement of the lever f^{10} . Assuming that the shifting of said lever f^{10} has moved the valves to the position shown in Fig. 6 of the drawings, the steam passage-ways are opened to the upper side of the mechanism, steam entering the port f^4 of the valve F through port b^3 , and passing through port f^6 into the opening b^{12} , and into the cylinder to cause a movement of the piston toward the left. This movement of the piston causes the steam on the opposite side thereof to pass from the cylinder into the opening b^{11} , through port f^6 of valve F', through port f^4 of said latter valve into the passage-way b^3 and into the recess e^{12} of the valve E, and into the passage-way b^5 to the exhaust opening b^9 , said recess e^{12} forming a bridge between the port b^3 and the passage-way b^5 . This movement of the piston is continued until it has approximately reached the end of its stroke, at which time the valve E has been shifted by the operation of the eccentric e^2 to a position where the steam cavity e^{13} on the opposite side of the valve E has passed to a position where communication is had between it and the port f^4 of

the valve F' through passage-way b^3 , thereby admitting steam to the cylinder through the valve F' and causing a movement of the piston in the opposite direction, the exhaust steam passing through the opening b^{12} through valve F and its port f^4 into the bridge formed by the opening e^{12} and into the passage-ways b^5 , b^7 , b^8 to the exhaust opening b^9 . From this it will be seen that the exhaust opening b^9 will form the sole exhaust passage-way for the exhaust steam when the valves F and F' are in this position; and also that the passage-ways b^3 alternately form the passage-ways for the live steam and the exhaust steam when the locomotive has its movement in the same direction.

When it is desired to reverse the engine, the lever f^{10} is moved to the opposite extreme of its length of movement, this movement passing the intermediate point and cutting off the steam supply, while the ports f^4 of valves F and F' are passed from a position in registration with ports b^3 to a position where registration is had between said ports f^4 and the ports b^4 , when the valves F and F' reach the position of the parts shown in Fig. 8, during this movement, the movement of said valves has placed ports f^3 and f^7 respectively as in Fig. 8, permitting the free running of the engine to drive out exhaust steam to retain the valve casing against material loss of heat while the live steam is cut off from the valves F and F'.

When the position shown in Fig. 7 is reached, the entrance of live steam and the discharge of exhaust steam is provided through the ports and passage-ways of the member B located below the plane of the axis of the several valves, the steam courses being clearly indicated in Fig. 7 by the arrows, the respective courses being substantially as heretofore described in connection with Fig. 6, the live steam, however, being initially delivered to the valve F' instead of valve F as indicated in Fig. 6, thereby providing the initial movement of the piston in a direction opposite that provided by the initial movement of the piston with the parts positioned as shown in Fig. 6, the movements of the valve E providing a shifting of the steam supply from one side of the piston to the opposite side, as heretofore indicated. When it is desired to stop the engine, the lever f^{10} is brought to an intermediate position, thereby placing the parts in the positions shown in Fig. 8 of the drawing, and cutting off the supply of steam to the cylinder, but leaving valve E bathed in live steam ready to be introduced to the cylinder upon movement of the valves F and F'.

While the showing in Figs. 6, 7 and 8 is such as to indicate the position of the valve E as being the same in each view, it will be

understood that said valve is changing its position constantly by reason of the eccentric e^2 . This change in position, however, does not affect the operation in any respect, since the arrangement of the parts provides that if the valves F and F' be positioned as shown in Fig. 6, live steam will be introduced either to valve F or valve F'; the only position in which a delivery of steam could not be made would be one in which the engine had stopped at such position as to place the recesses e^{13} in direct opposition to the walls between the passage-ways or ports b^3 and b^4 , this forming a dead center position and preventing the passage of steam to the cylinder irrespective of any movements of the valves F and F'. In connection with locomotives, this effect is overcome by reason of the advanced position of one eccentric over the other; in connection with stationary engines, the liability of this position being assumed by the valve E is practically eliminated by reason of the fact that the position of the parts can be controlled by a judicious cutting off of steam such as is employed in connection with other forms of construction.

By reason of the fact that the valve E is permanently bathed with live steam, it will be readily understood that the connection from boiler to said valve may be relatively short, thereby eliminating any requirement of the exposure of a pipe connection of considerable length; and it will also be understood that by reason of the fact that the entrance of the steam to the cylinder is controlled by the valves F and F' located in close proximity to the valve E, and necessarily heated to some extent by reason of such proximity to the live steam, the liability of providing a considerable amount of "dead" steam upon the cutting off of the steam by manipulation of the valves F and F' is eliminated, the dead steam being practically driven out by the movements of the piston due to momentum of the engine after steam has been cut off.

As will be readily understood, the oscillating movements of the valve E cause the valve members e^6 to alternately open and close the ports b^3 and b^4 . During the movements of said valve E to provide this variation, the opening of said ports is gradual to their maximum capacity, followed by a closing movement which is also gradual. This results in gradually closing off the exit for the exhaust steam as the piston approaches the end of its stroke, thereby tending to provide a steam cushion on the exhaust side of the piston to prevent injurious hammering.

While the several normal positions of the lever f^{10} provide for three distinct positions of the valves F and F', to produce the results heretofore referred to, the particular

construction and arrangement of the parts of the valve mechanism are such as to permit of an additional result being obtained, viz., the use of the steam on opposite sides of the piston for the purpose of obstructing or retarding the movement of the piston in either direction, thereby serving as an additional brake mechanism for quickly stopping the engine, this retaining of the piston practically locking the drive wheels against motion. To obtain this result the valves F and F' are shifted to a position where neither of the ports f^3 , f^4 and f^5 register with ports and passage-ways b^4 , b^5 and b^6 , the ports of the valves F and F' being in opposition to the walls formed by the member B. When in this position, live steam is prevented from entering either valve, and exhaust steam cannot pass from the valves through any of its ports in a direction leading to the exhaust openings; consequently any exhaust steam which may be in advance of the piston opposes the movement of the piston and effectually locks the piston against movement. This position of the valves can be obtained by movement of the lever f^{10} , placing the latter in a position intermediate either extreme of its movement and the central position. Not only can this absolute lock be provided, but in addition, a less abrupt retarding effect may be produced by partially opening the ports f^3 and f^5 to the passage-ways b^5 and b^6 , these variations in position of said ports f^3 and f^5 being possible without permitting live steam to enter, by reason of the distance between the opposing ports b^3 and b^4 , said distance providing for the requirement of a material movement of the valves between a positioning in registration of the port f^4 with either of the ports b^3 and b^4 .

The ability to provide the gradual retarding or absolute locking effect by providing a steam cushion in advance of the piston, permits of a complete control and a rapid stopping of the locomotive without producing the hammering effect common where the attempt is made to produce this result. In addition, this ability to provide for a rapid stopping also permits of a relatively rapid reversal in the direction of movement of the locomotive, since the latter can be quickly brought to a stop, and a continued movement of the lever f^{10} enables the reversing operation to take place. To control the speed of the locomotive, it is necessary only to vary the position of the ports f^4 relative to the ports b^3 or b^4 to provide for a more or less extended registration of the registering ports. And whatever the size of such registering opening may be, it will be readily understood that the area of the opening for the live steam into the cylinder is precisely the same as the area of the opening which permits of the exhaust from the

opposite side of the piston, thereby automatically balancing the mechanism. In addition to these several advantages provided by my improved construction, it will be understood that there is an entire elimination of the ordinary link-motion used in locomotives in connection with the reverse lever. The result normally produced by such link-motion is herein produced by a manipulation of the two valves F and F' by the lever f^{10} , this movement of the lever also providing the same result as is obtained by the use of a throttle lever in the locomotive. In other words, the valve mechanism herein shown and described combines all of the results produced by the operation of both throttle and reverse levers by the manipulation of a single lever, the particular arrangement of the parts providing for the automatic production of the necessary results required to produce the general result by a continued movement of the lever f^{10} from one extreme of its length of movement to its opposite extreme.

From the above description of parts, it will be seen that the valve mechanism is extremely compact, durable, simple and efficient in operation, provides for a maximum amount of variation in movements of the locomotive, and is of such a construction as to not only reduce friction but to reduce steam condensation to its minimum.

While I have herein shown and described one form for carrying my invention into effect, variations in the form and arrangement of the parts may be made therein to provide for special forms of steam engine construction; while such modifications are not disclosed herein, I desire it understood that I reserve the right to make such modifications and changes as may be required, as long as they may fall within the spirit and scope of my invention as disclosed in the claims.

Having thus described my invention and pointed out one particular form of mechanism for carrying the same into effect, what I claim as new is:—

1. In a steam engine, an oscillating rotary distributing valve exteriorly bathed with live steam, said valve also being movable to provide open communication with the exhaust steam passageways to permit exhaust steam bathing of the valve simultaneously with the bathing by live steam, said distributing valve having permanent live and exhaust steam cavities arranged alternately in circular succession.

2. In a steam engine, the combination with a valve casing having a bore, of an oscillating distributing valve mounted within said bore, said bore and the periphery of said valve being in open communication with a source of steam supply, exhaust steam cavities formed peripherally of and

movable with said valve, said valve having a cross sectional configuration to restrict the live steam to peripheral cavities spaced one from the other and from the exhaust steam cavities, and exhaust steam passageways within said casing, said passageways including portions located annularly with respect to the walls of said bore, and communicating with the exhaust cavities of the valve, whereby the exhaust steam will form a heating agent for preventing condensation of live steam within the bore.

3. In a steam engine, an oscillating distributing valve having its exterior in open communication with the source of steam supply, and permanently bathed with the live steam therefrom, and a throttle valve intermediate the distribution valve and the cylinder, said throttle valve controlling the passage of live steam to and exhaust steam from the cylinder.

4. In a steam engine, an oscillating distributing valve having its exterior in open communication with the source of steam supply and having exhaust steam cavities, and a throttle valve intermediate the distribution valve and the cylinder, said throttle valve controlling the passage of live steam to and exhaust steam from the cylinder the live and exhaust steam passing into contact with the distributing valve, and also having ports positioned to provide communication between the cylinder and the exhaust port of the engine when communication between the distribution valve and the cylinder is cut off.

5. In a steam engine, an oscillating distributing valve having its exterior in open communication with the source of steam supply, and a throttle valve intermediate the distribution valve and the cylinder, said throttle valve controlling the passage of live steam to and exhaust steam from the cylinder the live and exhaust steam passing into contact with the distributing valve, said throttle valve being movable at will to provide communication between the distributing valve and the cylinder at either one of two spaced points, said distributing valve having permanent live and exhaust steam cavities arranged alternately in circular succession.

6. In a steam engine, a distributing valve, and two throttle valves positioned on opposite sides of the distributing valve, said throttle valves providing communication between the distributing valve and the cylinder and between the cylinder and an exhaust port, the exhaust steam normally passing into contact with the distributing valve intermediate the throttle valves and the exhaust port, and also annularly with respect to and spaced from the distributing valve in exhausting from one end of the cylinder.

7. In a steam engine, a distributing valve,

and two throttle valves positioned on opposite sides of the distributing valve, said throttle valves providing communication between the distributing valve and the cylinder and between the cylinder and an exhaust port, the exhaust steam normally passing into contact with the distributing valve intermediate the throttle valves and the exhaust port, and also annularly with respect to and spaced from the distributing valve in exhausting from one end of the cylinder, each of said valves having an oscillatory movement.

8. In a steam engine, a distributing valve, and two throttle valves positioned on opposite sides of the distributing valve, the axis of said valves being on approximately the same plane, said throttle valves providing communication between the distributing valve and the cylinder and between the cylinder and an exhaust port, the exhaust steam normally passing into contact with the distributing valve intermediate the throttle valves and the exhaust port, and also annularly with respect to and spaced from the distributing valve in exhausting from one end of the cylinder.

9. In a steam engine, a valve casing having a bore, live steam passageway within the casing, and an oscillating distributing valve mounted within said bore, said valve having alternately arranged cavities located peripherally of the valve for live and exhaust steam, the live steam cavities being in permanently open communication with said live steam passageway.

10. In a steam engine, an oscillating distributing valve having independent peripheral cavities for live and exhaust steam, the cavities for exhaust steam being located intermediate the live steam cavities, the live steam cavities being in permanent open communication with the source of steam supply.

11. In a steam engine, a valve casing having valve cavities, a distributing valve, two reversing valves positioned on opposite sides of the distributing valve, two pairs of ports connecting the distributing valve cavity with each of the reversing valve cavities, a port connecting each reversing valve cavity with the cylinder of the engine, and means for manually moving said reversing valves into registration with predetermined ports of the plurality of ports.

12. In a steam engine, a valve casing, valve cavities therein, having their axes in horizontal alinement, a distributing valve mounted in an intermediate cavity, throttle valves located on opposite sides of the distributing valve, and a pair of exhaust ports in the casing and positioned on opposite sides of one of the throttle valves.

13. In a steam engine, a valve casing, a distributing valve having peripheral steam cavities, a throttle valve mounted on each

side of said distributing valve, two pairs of ports for providing communication between the distributing valve and each throttle valve, and means for manually moving said

5 throttle valves in unison to provide steam communication between said throttle valves and the distributing valve through a predetermined port of each pair of ports.

10 14. In a steam engine, a valve casing, a distributing valve having peripheral steam cavities, a throttle valve mounted on each side of said distributing valve, a pair of ports for providing communication between the distributing valve and each throttle

15 valve, the ports of each pair being located on opposite sides of a line connecting the axes of the several valves, and means for moving said throttle valves to provide steam communication between the distributing

20 valve and each throttle valve through either one of the pair of ports, the selected ports being on the same side of said line.

15. In a steam engine, a distributing valve, a throttle valve located intermediate

25 the distributing valve and the cylinder and providing steam communication between the distributing valve and the cylinder, and an exhaust port, said throttle valve being movable to positions to provide exhaust steam communication either direct to the ex-

30 haust port or indirect to said port through the distributing valve.

16. In a steam engine, a distributing valve, a throttle valve located intermediate the

35 distributing valve and the cylinder and providing steam communication between the distributing valve and the cylinder and an exhaust port, said throttle valve being movable to positions to provide exhaust steam communication either direct to the exhaust

40 port or indirect to said port through the distributing valve, said throttle valve being also movable to a position to prevent escape of exhaust steam from the cylinder.

45 17. In a steam engine, a distributing valve, a pair of throttle valves located on opposite sides of the distributing valve and intermediate said distributing valve and cylinder, a pair of exhaust ports positioned on opposite

50 sides of one of the throttle valves, said throttle valves being movable at will and in unison and positionable to provide exhaust steam communication with a selective one of the pairs of exhaust ports.

55 18. In a steam engine, a distributing valve, a pair of throttle valves located on opposite sides of the distributing valve and intermediate said distributing valve and cylinder, a pair of exhaust ports positioned on opposite

60 sides of one of the throttle valves, said

throttle valves being movable at will and in unison and positionable to provide exhaust steam communication with a selective one of the pair of exhaust ports, the throttle valves forming the exhaust port selecting instru-

65 mentality.

19. In a steam engine, a casing, a distributing valve, a pair of throttle and reversing valves located intermediate the distributing valve and the cylinder, said throttle and reversing valves being movable to provide reversal of the movement of the engine, and a pair of exhaust ports in said casing spaced from the distributing valve, said

70 ports being rendered active separately and in alternation in correspondence with the reversal of the direction of movement of the engine.

20. In a steam engine, a distributing valve comprising a body portion having peripheral

80 cavities permanently serving as live and exhaust steam passageways, said cavities being arranged in alternation, the live steam cavities each being permanently open to a common steam port positioned externally of the

85 body portion.

21. A distributing valve for steam engines comprising a body portion having peripheral cavities for live steam, each permanently open to a common live steam port positioned

90 externally of the body portion and removable members mounted in alternation with said cavities, each of said members having an exhaust steam cavity.

22. In a steam engine, a valve casing, a

95 distributing valve, a throttle valve mounted intermediate the distributing valve and the cylinder, a pair of ports for selectively connecting the distributing and throttle valves to provide live steam communication be-

100 tween the distributing valve and the cylinder, exhaust ports carried by the casing, and a passage-way formed on each side of said pair of ports, each passage-way being in open communication with an exhaust port,

105 said throttle valve having three ports, one of which is adapted to be brought into registration with either one of the pair of ports, the two other ports of the valve being registrable with said passage-ways when said

110 pair of ports are out of registration with the single port.

In testimony whereof I have hereunto set my hand in presence of two subscribing witnesses.

JOHN PHILLIPS.

Witnesses:

L. D. HEFLIN,
THOS. D. HITCHCOCK.