

(No Model.)

2 Sheets—Sheet 1.

J. H. CLAPP.

SOAP PRESS.

No. 340,979.

Patented May 4, 1886.

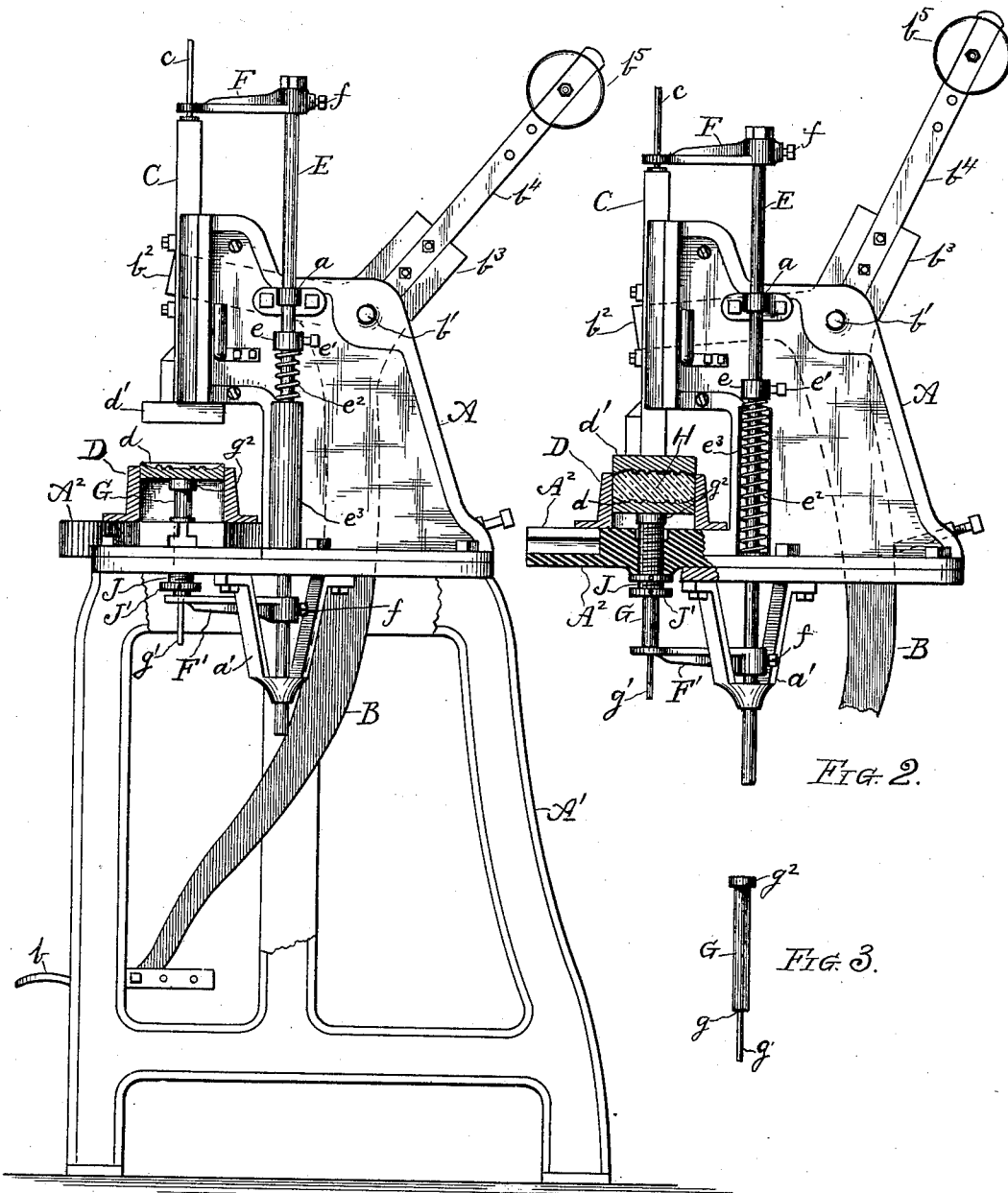

Witnesses:
J. B. Halpenny
David Stevens

FIG. 1.

Inventor:
 James H. Clapp
 By Gridley & Fletcher
 Attys.

(No Model.)

2 Sheets—Sheet 2.

J. H. CLAPP.
SOAP PRESS.

No. 340,979.

Patented May 4, 1886.

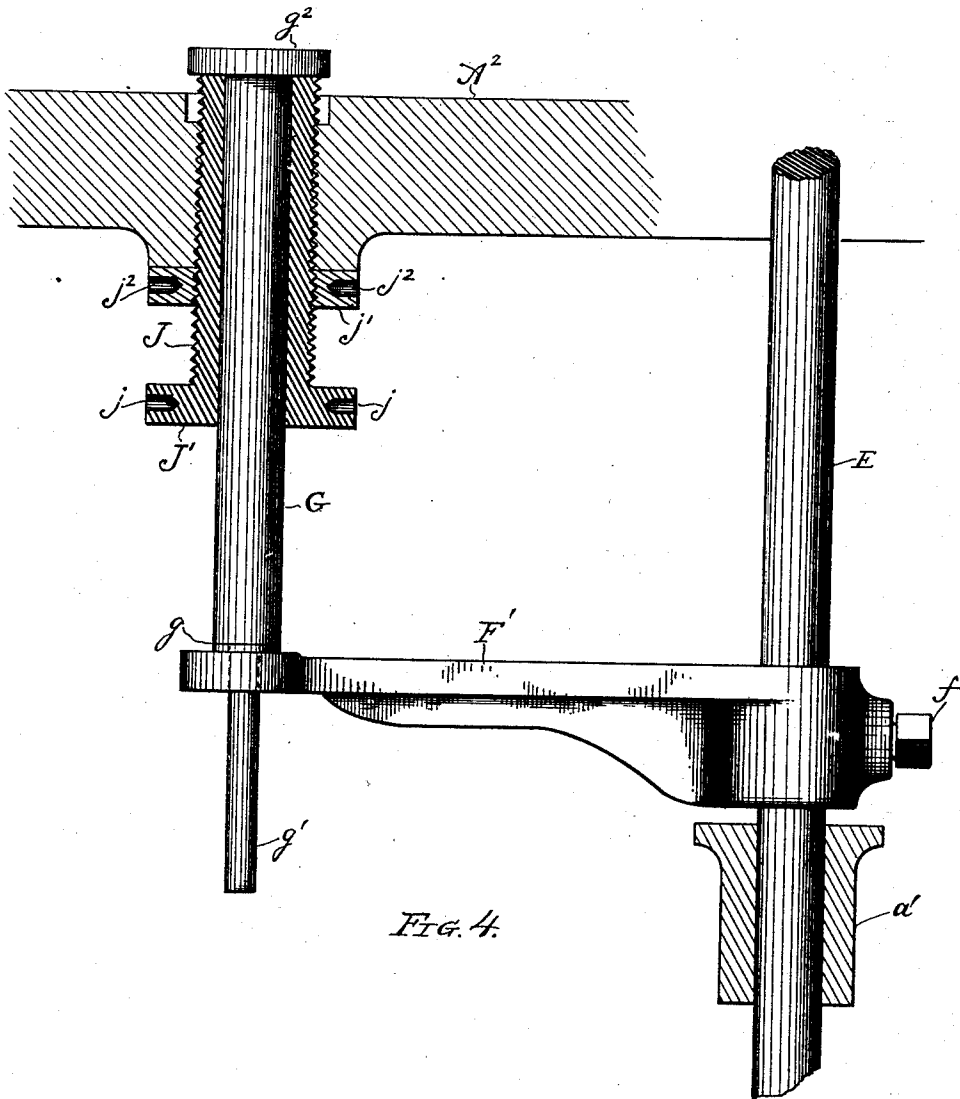

FIG. 4.

Witnesses:
J. B. Halpenny
David Stevens.

Inventor:
James H. Clapp
By Gridley & Fletcher
Attys.

UNITED STATES PATENT OFFICE.

JAMES H. CLAPP, OF CHICAGO, ILLINOIS, ASSIGNOR TO JAMES LEWIS BOARD, OF SAME PLACE.

SOAP-PRESS.

SPECIFICATION forming part of Letters Patent No. 340,979, dated May 4, 1886.

Application filed January 23, 1886. Serial No. 189,368. (No model.)

To all whom it may concern:

Be it known that I, JAMES H. CLAPP, of Chicago, in the county of Cook and State of Illinois, have invented certain new and useful Improvements in Soap-Presses, of which the following is a description, reference being had to the accompanying drawings, in which—

Figure 1 is a side elevation of said press, in which a portion of the frame is broken away and the lower die and die-box are shown in transverse section to reveal the working parts. Fig. 2 is a similar view, in detail, of a portion of said press, showing a transverse sectional view of the table and dies, the latter being at the point of compression. Fig. 3 is a detail view of the removable piston used to raise the lower section of the die upon the return-stroke of the cross-head; and Fig. 4 is an enlarged detail view, partly in section, of the device for adjusting the die to the thickness of the soap-cake.

Like letters of reference indicate like parts in the different figures.

The object of my invention is to provide an automatic device to be used in connection with soap-presses, whereby after compressing the soap-cake the matrix may be raised out of the box by a positive and certain movement, thus enabling the cake, when formed, to be removed at will.

A further object is to render said device adjustable to the varying thickness of the soap-cakes, and to initiate a quick reverse movement of the dies after the compressing-stroke is completed, and while the counterpoise-weight is in a position to exert its least gravitating force, all of which are hereinafter more particularly described, and pointed out in the claims.

In the drawings, A represents the body of the machine, the bed of which is supported upon the usual frame-work, A', said body being of the ordinary pattern in machines of its class. A foot-lever, B, provided with a treadle, b, is pivoted to the frame at b', and is provided with diverging arms b² b³, the former of which is extended forward and passes through a slot in the usual vertical reciprocating cross-head, C, which is fitted to slide in a suitable bearing, and is operated by the movement of the arm b². The arm b³ has rigidly attached thereto a sec-

ondary arm or bar, b⁴, to which is secured an adjustable counterpoise or weight, b⁵.

Removably attached to the bed A² by means of bolts, or in any well-known way, is a metal receiving-box, D, into which is loosely but accurately fitted one member, d, of a die, the counterpart, d', of which is rigidly attached to the bottom of the cross-head C.

Near the top of the frame A, and upon one side, is bolted a lug, a, and upon the bottom of the bed A², and secured thereto in like manner, is a depending bracket, a', the two forming bearings for a vertical rod or bar, E, which is loosely fitted therein. At the top of said bar is rigidly but adjustably attached a horizontal projecting arm, F, perforated at its extremity, through which is loosely inserted a vertical rod, c, rigidly attached to the cross-head C. A like arm, F', is likewise attached to said bar E, near its lower end, both of said arms being adjustably secured to the bar E by means of set-screws f, f'. Through the perforated extremity of the arm F' is loosely protruded a bolt or pin, G, (shown in detail in Fig. 3,) provided with a shoulder, g, and a smaller portion or extension, g'. A head, g², is likewise formed upon the upper end. Said pin is fitted loosely in a bearing in the bed, so as to insure an accurate movement thereof, into which it is placed before inserting the die d in the box D. An adjustable collar, e, is attached to the bar E, below the lug a, by means of the set-screw e'. Between the collar e and the bed A², I place a spiral spring, e², the upward pressure of which may be regulated by the position of the collar e. Said spring is protected by means of a shield, e³, surrounding the same.

In lieu of removing the matrix d and inserting blocks or pieces of leather or other material of varying thickness beneath said matrix, in order to adjust it to form the soap-cake of the desired thickness, I insert an adjustable screw-bushing, J, (better shown in Fig. 4,) within the perforation in the bed, and which forms a bearing for the pin G, the head g² of said pin being adapted to rest upon the upper end of said bushing when the latter is above the surface of the bed. Said part J is preferably provided with an enlargement, J', at its lower end, into which is formed a series of holes, j, into which a pin may be inserted for turn-

ing said screw and adjusting its height. When so adjusted, the same may be locked by means of a jam-nut, j' , provided with like holes, j^2 .

5 It is obvious that the part J' , as well as the nut j' , may be made square or polygonal in form, so as to be adjusted by means of a wrench in any well-known way. Said device is capable of the most exact adjustment, while
10 at the same time it furnishes a solid and firm foundation for the matrix.

The operation of said machine is as follows: Assuming the parts to be in their normal position, as shown in Fig. 1, the soap to be
15 pressed is placed between the dies d d' , when a quick pressure is made upon the treadle b . This movement forces the die d downwardly within the box D, which, by means of the bolt G, presses down upon the arm F' , thus com-
20 pressing the spring e^2 . The die d' is forced downwardly within the box by means of the arm b^2 , thus compressing the soap H, Fig. 2, into a compact cake, the momentum of the weight b^5 producing a powerful impact of the
25 die d' therewith, thus rendering the body of the cake dense and its surface smooth and glossy. The power stored in the spring e^2 immediately initiates an upward movement of the bar E, thus causing the pin G to force the
30 die d upwardly until its upper face is even with the top of the box D, when the cake may be readily removed. In addition to the force of the spring e^2 , which, as stated, serves to initiate the upward movement of the bar E, the cross-
35 head C, acting upon the arm F, continues said movement, and renders it positive and certain at all times, thus insuring the delivery of the compressed cake upon each return-stroke. By means of the set-screws f f the arms F F'
40 may be adjusted at will to conform in movement to the height of the die-box, and thus deliver the cake.

Having thus described my invention, what I claim, and desire to secure by Letters Patent,
45 is—

1. The combination, with a soap-press having a loose matrix inclosed within a box, the counterpart of which matrix is attached to a reciprocating cross-head, of a bar arranged to move
50 longitudinally in bearings and provided with arms at or near its respective ends, which are in turn connected with said cross-head and loose matrix, substantially in the manner and for the purposes specified.

55 2. In a soap-press, a rigid bar loosely sup-

ported in bearings in which it is fitted to slide, and provided with rigid arms at or near its ends, one of which is connected with the cross-head, and the other by an intermediate pin, G, or equivalent means, with the lower section
60 of the die, whereby the latter may be positively raised to the surface of the box upon the return-stroke of the cross-head, substantially as described.

3. The combination, with a soap-press the
65 male die of which is attached to a reciprocating cross-head operated by a lever and counterpoise-weight, of the reciprocating bar E, provided with arms F F', the former of which is connected with the cross-head, and the latter
70 with a loose vertical pin in contact with the movable matrix d , substantially as and for the purposes set forth.

4. The combination, with a soap-press the
75 male die of which is attached to a reciprocating cross-head operated by a lever and counterpoise-weight, of the reciprocating bar E, provided with adjustable arms F F', the former of which is connected with the cross-head, and the latter with a loose vertical pin in contact
80 with the movable matrix d , substantially as described, and for the purposes specified.

5. The combination, with a soap-press the
85 male die of which is attached to a reciprocating cross-head operated by a lever and counterpoise-weight, of the reciprocating bar E, provided with arms F F', the former of which is connected with the cross-head, and the latter with a loose vertical pin beneath and in contact with the movable matrix d , and the spring
90 e , for initiating a backward stroke of the cross-head, substantially as described.

6. In a soap-press, the reciprocating bar E, having adjustable arms F F' connected with the respective dies thereof, substantially as
95 and for the purposes set forth.

7. In combination with the dies and die-box of a soap-press, the adjustable device J, whereby said dies may be adjusted to form cakes of
100 varying thickness, substantially as specified.

8. In combination with the dies and die-box of a soap-press, the adjustable die-support J and means, as a jam-nut, for locking the same in position when adjusted, substantially in the manner and for the purposes described.

JAMES H. CLAPP.

Witnesses:

D. H. FLETCHER,
J. B. HALPENNY,
DAVID STEVENS.