

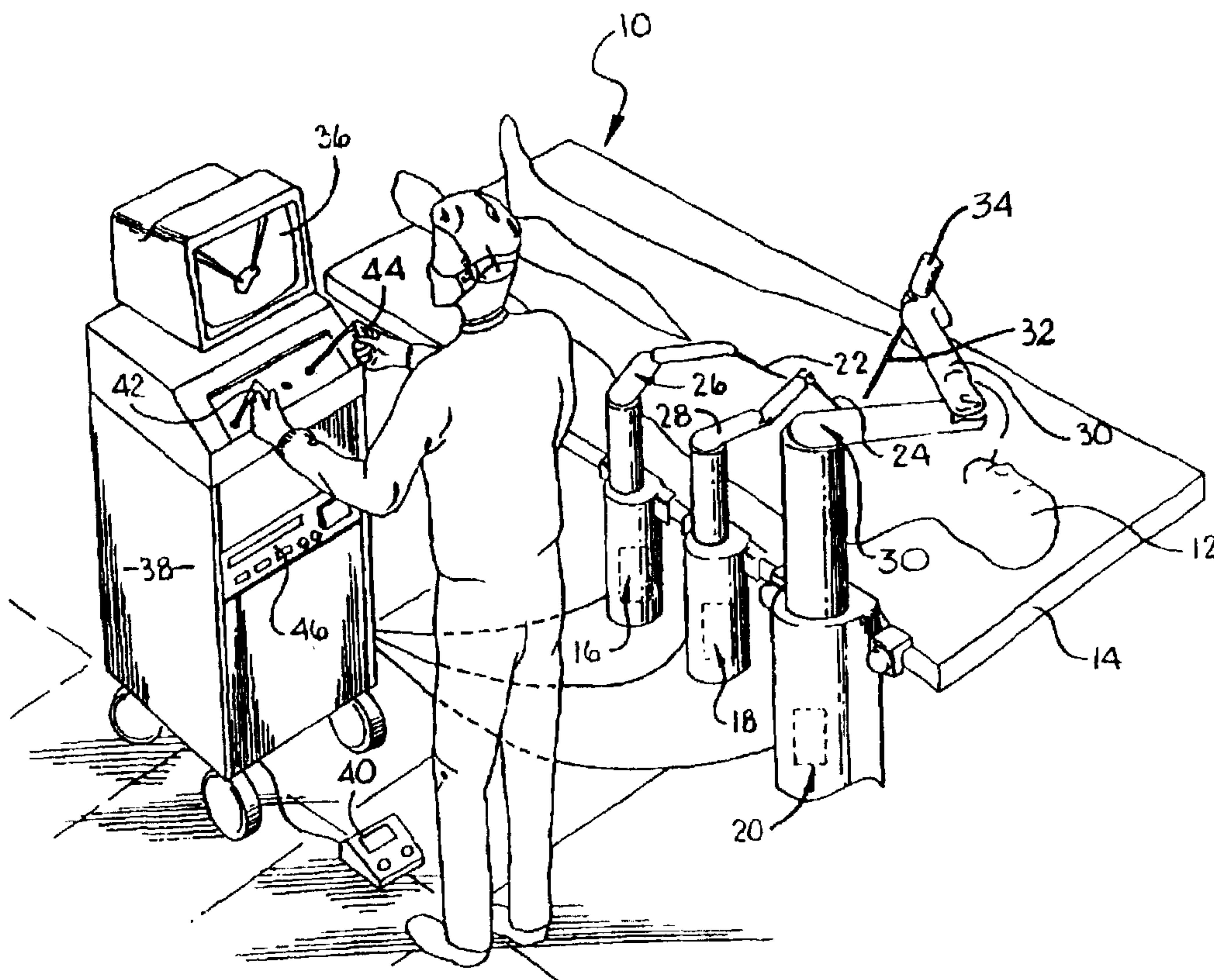

(22) Date de dépôt/Filing Date: 2002/09/04
 (41) Mise à la disp. pub./Open to Public Insp.: 2003/03/07
 (45) Date de délivrance/Issue Date: 2012/06/05
 (30) Priorité/Priority: 2001/09/07 (US09/949050)

(51) Cl.Int./Int.Cl. *A61B 17/00* (2006.01),
A61B 1/01 (2006.01), *A61B 1/045* (2006.01),
A61B 19/00 (2006.01), *B25J 13/00* (2006.01),
A61B 18/00 (2006.01)
 (72) Inventeurs/Inventors:
 WANG, YULUN, US;
 GHODOUSSI, MODJTABA, US;
 UECKER, DARRIN, US;
 WRIGHT, JAMES, US;
 MANGASER, AMANTE, US
 (73) Propriétaire/Owner:
 COMPUTER MOTION, INC., US
 (74) Agent: RICHES, MCKENZIE & HERBERT LLP

(54) Titre : SYSTEME DE MODULARITE POUR CHIRURGIE ASSISTEE PAR ORDINATEUR
 (54) Title: MODULARITY SYSTEM FOR COMPUTER ASSISTED SURGERY



(57) Abrégé/Abstract:

A medical system that allows a medical device to be controlled by one of two input devices. The input devices may be consoles that contain handles and a screen. The medical devices may include robotic arms and instruments used to perform a medical procedure. The system may include an arbitrator that determines which console has priority to control one or more of the robotic arms/instruments.



ABSTRACT

A medical system that allows a medical device to be controlled by one of two input devices. The input devices may be consoles that contain handles and a screen. The medical devices may include robotic arms and instruments used to perform a medical procedure. The system may include an arbitrator that determines which console has priority to control one or more of the robotic arms/instruments.

MODULARITY SYSTEM FOR COMPUTER ASSISTED SURGERY

1. Field of the Invention

The present invention relates to a medical robotic system.

2. Background Information

Blockage of a coronary artery may deprive the heart of blood and oxygen required to sustain life. The blockage may be removed with medication or by an angioplasty. For severe blockage a coronary artery bypass graft (CABG) is performed to bypass the blocked area of the artery. CABG procedures are typically performed by splitting the sternum and pulling open the chest cavity to provide access to the heart. An incision is made in the artery adjacent to the blocked area. The internal mammary artery is then severed and attached to the artery at the point of incision. The internal mammary artery bypasses the blocked area of the artery to again provide a full flow of blood to the heart. Splitting the sternum and opening the chest cavity can create a tremendous trauma to the patient. Additionally, the cracked sternum prolongs the recovery period of the patient.

Computer Motion of Goleta, California provides a system under the trademark ZEUS that allows a surgeon to perform a minimally invasive CABG procedure. The procedure is performed with instruments that are inserted through small
5 incisions in the patient's chest. The instruments are controlled by robotic arms. Movement of the robotic arms and actuation of instrument end effectors are controlled by the surgeon through a pair of handles and a foot pedal that are coupled to an electronic controller. Alternatively,
10 the surgeon can control the movement of an endoscope used to view the internal organs of the patient through voice commands.

The handles and a screen are typically integrated into a console that is operated by the surgeon to control the
15 various robotic arms and medical instruments of a ZEUS system. Utilizing a robotic system to perform surgery requires a certain amount of training. It would be desirable to provide a system that would allow a second surgeon to assist another surgeon in controlling a robotic
20 medical system. The second surgeon could both teach and assist a surgeon learning to perform a medical procedure

with a ZEUS system. This would greatly reduce the time required to learn the operation of a robotically assisted medical system.

U.S. Patent No. 5,217,003 issued to Wilk discloses a surgical system which allows a surgeon to remotely operate robotically controlled medical instruments through a telecommunication link. The Wilk system only allows for one surgeon to operate the robotic arms at a given time. Wilk does not disclose or contemplate a system which allows two different surgeons to operate the same set of robotic arms.

U.S. Patent No. 5,609,560 issued to Ichikawa et al. and assigned to Olympus Optical Co. Ltd. discloses a system that allows an operator to control a plurality of different medical devices through a single interface. The Olympus patent does not disclose a system which allows multiple input devices to control a single medical device.

BRIEF SUMMARY OF THE INVENTION

A medical system that includes a single medical device that can be controlled by one of two input device.

In one aspect of the present invention, there is provided a medical system, comprising: a first medical device; a first input device that can control said first medical device; a second input device that can control said first medical device; and an arbitrator that allows either said first input device or said second input device to control said first medical device, wherein said first and second input devices each transmit a packet of information, each packet including an indication that is used by said arbitrator to allow either said first input device or second input device to control said first medical device.

In a further aspect of the present invention, there is provided a medical system, comprising: a first medical device; first input means for controlling said first medical device; second input means for controlling said first medical device; and arbitrator means for allowing either said first input means or said second input means to control said first medical device, wherein said first and second input means each transmit a packet of information, each packet including an indication that is used by said

arbitrator means to allow either said first input means or second input means to control said first medical device.

In yet a further aspect of the present invention, there is provided a medical system, comprising: a first robotic arm; a first medical instrument coupled to said first robotic arm; a second robotic arm; a second medical instrument coupled to said second robotic arm; a third robotic arm that can hold an endoscope coupled to a camera; a first console that can control said first and second robotic arms; a second console that can control said first and second robotic arms; a first endoscopic input device that can control said third robotic arm; a second endoscopic input device that can control said third robotic arm; an arbitrator coupled to said first robotic arm, said second robotic arm, said third robotic arm, said first console, said second console, said first endoscopic input device and said second endoscopic input device, wherein said first and second consoles each transmit a packet of information to said arbitrator, the packet of information including an indication used by said arbitrator to determine whether said first and second robotic arms are to be controlled by said first console or said second console.

In yet a further aspect of the present invention, there is provided a medical system, comprising: a first robotic

arm; a first medical instrument coupled to said second robotic arm; a second robotic arm; a second medical instrument coupled to said second robotic arm; a third robotic arm that can hold an endoscope coupled to a camera; a first console that can control said first and second robotic arms; a second console that can control said first and second robotic arms; a first endoscopic input device that can control said third robotic arm, said first endoscopic input device associated with said first console; a second endoscopic input device that can control said third robotic arm, said second endoscopic input device associated with said second console; arbitrator means for allowing said first and second robotic arms to be controlled by either said first console or said second console, and said third robotic arm to be controlled by either said first endoscopic input device or said second endoscopic input device, wherein said first and second consoles each transmit a packet of information including an indication to said arbitrator means, said indication used by said arbitrator means to determine whether said first and second robotic arms are to be controlled by said first console or second console and whether said third robotic arm is to be controlled by said first endoscopic input device or said second endoscopic input device.

BRIEF DESCRIPTION OF THE DRAWINGS

Figure 1 is a perspective view of a medical robotic system;

Figure 2 is an exploded side view of an instrument of the robotic system;

Figure 3 is an illustration of network system;

Figure 4 is an illustration of a "surgeon" side of the system;

Figure 5 is an illustration of a "patient" side of the system;

Figure 6 is a schematic showing various fields of a packet transmitted across a communication network;

Figure 7 is an illustration showing an alternate embodiment of the network system.

15

DETAILED DESCRIPTION

Referring to the drawings more particularly by reference numbers, Figure 1 shows a system 10 that can perform minimally invasive surgery. In one embodiment, the system 10 is used to perform a minimally invasive coronary artery bypass graft (MI-CABG) and other anastomotic procedures. Although a MI-CABG procedure is shown and described, it is to be understood that the system may be used for other surgical procedures. For example, the system can be used to suture any pair of vessels. The system 10 can be used to perform a procedure on a patient 12 that is typically lying on an operating table 14. Mounted to the operating table 14 is a first articulate arm 16, a second articulate arm 18 and a third articulate arm 20. The articulate arms 16, 18 and 20 are preferably mounted to the table 14 so that the arms are at a same reference plane as the patient. Although three articulate arms are shown and described, it is to be understood that the system may have any number of arms.

The first and second articulate arms 16 and 18 each have a surgical instrument 22 and 24, respectively, coupled

to robotic arms 26 and 28, respectively. The third
articulate arm 20 includes a robotic arm 30 that holds and
moves an endoscope 32. The instruments 22 and 24, and
endoscope 32 are inserted through incisions cut into the
5 skin of the patient. The endoscope has a camera 34 that is
coupled to a television monitor 36 which displays images of
the internal organs of the patient.

The first 16, second 18, and third 20 articulate arms
are coupled to a controller 38 which can control the
10 movement of the arms. The controller 38 is connected to an
input device 40 such as a foot pedal that can be operated
by a surgeon to move the location of the endoscope 32. The
controller 38 contains electrical circuits, such as a
processor, to control the robotic arms 26, 28 and 30. The
15 surgeon can view a different portion of the patient by
depressing a corresponding button(s) of the pedal 40. The
controller 38 receives the input signal(s) from the foot
pedal 40 and moves the robotic arm 30 and endoscope 32 in
accordance with the input commands of the surgeon. The
20 robotic arm may be a device that is sold by the assignee of
the present invention, Computer Motion, Inc. of Goleta,

California, under the trademark AESOP. The system is also described in U.S. Patent No. 5,657,429 issued to Wang et al., which is hereby incorporated by reference. Although a foot pedal 40 is shown and described, it is to be understood that the system may have other input means such as a hand controller, or a speech recognition interface.

The instruments 22 and 24 of the first 16 and second 18 articulate arms, respectively, are controlled by a pair of master handles 42 and 44 that can be manipulated by the surgeon. The handles 42 and 44, and arms 16 and 18, have a master-slave relationship so that movement of the handles 42 and 44 produces a corresponding movement of the surgical instruments 22 and 24. The handles 42 and 44 may be mounted to a portable cabinet 46. The handles 42 and 44 are also coupled to the controller 38.

The controller 38 receives input signals from the handles 42 and 44, computes a corresponding movement of the surgical instruments, and provides output signals to move the robotic arms 26 and 28 and instruments 22 and 24. The entire system may be a product marketed by Computer Motion under the trademark ZEUS. The operation of the system is

also described in U.S. Patent No. 5,762,458 issued to Wang et al. and assigned to Computer Motion, which is hereby incorporated by reference.

Figure 2 shows one of the surgical instruments 22 or 24. The instrument 22 or 24 includes an end effector 48 that is coupled to an actuator rod 50. The actuator rod 50 is coupled to a motor 52 by an adapter 54. The motor 52 actuates the end effector 48 by moving the actuator rod 50. The actuator rod 50 is coupled to a force sensor 56 that can sense the force being applied by the end effector 48. The force sensor 56 provides an analog output signal that is sent to the controller shown in Fig. 1.

The adapter 54 is coupled to a gear assembly 58 located at the end of a robotic arm 26 or 28. The gear assembly 58 can rotate the adapter 54 and end effector 48. The actuator rod 50 and end effector 48 may be coupled to the force sensor 56 and motor 52 by a spring biased lever 60. The instrument 22 or 24 may be the same or similar to an instrument described in the '458 patent.

Figure 3 shows a system 100 that allows two different input devices to control one medical device. The input

devices may be a first console 102 and a second console 104. The consoles 102 and 104 may each include the screen 36, handles 42 and 44, foot pedal (not shown) and controller 38 shown in Fig. 1. The medical devices may include the robotic arms 26, 28 and 30 and/or instruments 22 and 24 shown in Fig. 1. In general, the system allows a surgeon at either console 102 or 104 to control a medical device 22, 24, 26, 28 and or 30. For example, the surgeon at console 102 can move the robotic arms 26 and 28 through movement of the handles 42 and 44. The surgeon at console 104 can override the input from console 102 and control the movement of the robotic arms 26 and 28 through the movement of the console handles.

The consoles 102 and 104 are coupled to a network port 106 by a pair of interconnect devices 108 and 110. The network port 106 may be a computer that contains the necessary hardware and software to transmit and receive information through a communication link 112 in a communication network 114.

Consoles 102 and 104 provided by Computer Motion under the ZEUS mark provide output signals that may be

incompatible with a computer. The interconnect devices 108 and 110 may provide an interface that conditions the signals for transmitting and receiving signals between the consoles 102 and 104 and the network computer 106.

5 It is to be understood that the computer and/or consoles 102 and 104 may be constructed so that the system does not require the interconnect devices 108 and 110. Additionally, the consoles 102 and 104 may be constructed so that the system does not require a separate networking
10 computer 106. For example, the consoles 102 and 104 may be constructed and/or configured to directly transmit information through the communication network 114.

The system 100 may include a second network port 116 that is coupled to a device controller(s) 118 and the
15 communication network 114. The device controller 118 controls the robotic arms 26, 28 and 30 and instruments 22 and 24. The second network port 116 may be a computer that is coupled to the controller 118 by an interconnect device 120. Although an interconnect device 120 and network
20 computer 116 are shown and described, it is to be

understood that the controller 118 can be constructed and configured to eliminate the device 120 and/or computer 116.

The communication network 114 may be any type of communication system including but not limited to, the internet and other types of wide area networks (WANs), intranets, local area networks (LANs), public switched telephone networks (PSTN), integrated services digital networks (ISDN). It is preferable to establish a communication link through a fiber optic network to reduce latency in the system. Depending upon the type of communication link selected, by way of example, the information can be transmitted in accordance with the user datagram protocol/internet protocol (UDP/IP) or asynchronous transfer mode/_____ (ATM/AAL1) network protocols. The computers 112 and 116 may operate in accordance with an operating system sold under the designation VxWORKS by _____. By way of example, the computers 112 and 116 may be constructed and configured to operate with 100-base T Ethernet and/or 155 Mbps fiber ATM systems.

Figure 4 shows an embodiment of a "surgeon" side of the system. Each console 102 and 104 may be accompanied by a touchscreen computer 122 and an endoscope interface computer 124. The touchscreen computer 122 may be a device
5 sold by Computer Motion under the trademark HERMES. The touchscreen 122 allows the surgeon to control and vary different functions and operations of the instruments 22 and 24. For example, the surgeon may vary the scale between movement of the handles 42 and 44 and movement of
10 the instruments 22 and 24 through a graphical user interface (GUI) of the touchscreen 122. The touchscreen 122 may have another GUI that allows the surgeon to initiate an action such as closing the gripper of an instrument.

15 The endoscope computer 124 may allow the surgeon to control the movement of the robotic arm 30 and the endoscope 32 shown in Fig. 1. The endoscope computer 124 may be an alternate to, or in addition to, the foot pedal 40 shown in Fig. 1. The endoscope computer 124 may be a
20 device sold by Computer Motion under the trademark SOCRATES

The touchscreen 122 and endoscope computers 124 may be coupled to the network computer 106 by RS232 interfaces.

A ZEUS console will transmit and receive information that is communicated as analog, digital or quadrature signals. The network computer 112 may have analog input/output (I/O) 126, digital I/O 128 and quadrature 130 interfaces that allow communication between the console 102 or 104 and the network 114. By way of example, the analog interface 126 may transceive data relating to handle position, tilt position, in/out position and foot pedal information (if used). The quadrature signals may relate to roll and pan position data. The digital I/O interface 128 may relate to cable wire sensing data, handle buttons, illuminators (LEDs) and audio feedback (buzzers). The position data is preferably absolute position information. By using absolute position information the robotic arms can still be moved even when some information is not successfully transmitted across the network 114. If incremental position information is provided, an error in the transmission would create a gap in the data and possibly inaccurate arm movement. The network computer 112

may further have a screen 132 that allows for a user to operate the computer 112.

Figure 5 shows an embodiment of a "patient" side of the system 100. The controller 118 may include three separate
5 controllers 134, 136 and 138. The controller 134 may receive input commands, perform kinematic computations based on the commands, and drive output signals to move the robotic arms 26 and 28 and accompanying instruments 22 and 24 to a desired position. The controller 136 may receive
10 commands that are processed to both move and actuate the instruments 22 and 24. Controller 138 may receive input commands, perform kinematic computations based on the commands, and drive output signals to move the robotic arm 30 and accompanying endoscope 32.

15 Controllers 134 and 136 may be coupled to the network computer 116 by digital I/O 140 and analog I/O 142 interfaces. The computer 116 may be coupled to the controller 138 by an RS232 interface. Additionally, the computer 116 may be coupled to corresponding RS232 ports of
20 the controllers 134 and 136. The RS232 ports of the

controllers 134 and 136 may receive data such as movement scaling and end effector actuation.

The robotic arms and instruments contain sensors, encoders, etc. that provide feedback information. Some or
5 all of this feedback information may be transmitted over the network 114 to the surgeon side of the system. By way of example, the analog feedback information may include handle feedback, tilt feedback, in/out feedback and foot pedal feedback. Digital feedback may include cable
10 sensing, buttons, illumination and auditory feedback. The computer 116 may be coupled to a screen 142.

The computers 106 and 116 may packetize the information for transmission through the communication network 114. Each packet will contain two types of data, robotic data
15 and RS232 data. Robotic data may include position information of the robots, including input commands to move the robots and position feedback from the robots. RS232 data may include functioning data such as instrument scaling and actuation.

20 Because the system transmits absolute position data the packets of robotic data can be received out of sequence.

This may occur when using a UDP/IP protocol which uses a best efforts methodology. The computers 106 and 116 are constructed and configured to disregard any "late" arriving packets with robotic data. For example, the computer 106
5 may transmits packets 1, 2 and 3. The computer 116 may receive the packets in the order of 1, 3 and 2. The computer 116 will disregard the second packet 2. Disregarding the packet instead of requesting a re-transmission of the data reduces the latency of the system.
10 It is desirable to minimize latency to create a "real time" operation of the system.

It is preferable to have the RS232 information received in strict sequential order. Therefore the receiving computer will request a re-transmission of RS232 data from
15 the transmitting computer if the data is not errorlessly received. RS232 data such as motion scaling and instrument actuation must be accurately transmitted and processed to insure that there is not an inadvertent command.

The computers 106 and 116 can multiplex the RS232 data
20 from the various input sources. The computers 106 and 116 may have first-in first-out queues (FIFO) for transmitting

information. Data transmitted between the computer 106 and the various components within the surgeon side of the system may be communicated through a protocol provided by Computer Motion under the name HERMES NETWORK PROTOCOL
5 (HNP). Likewise, information may be transmitted between components on the patient side of the system in accordance with HNP.

In addition to the robotic and RS232 data, the patient side of the system will transmit video data from the
10 endoscope camera 34. To reduce latency in the system, the computer 116 can multiplex the video data with the robotic/RS232 data onto the communication network. The video data may be compressed using conventional JPEG, etc. compression techniques for transmission to the surgeon side
15 of the system.

Each packet 150 may have the fields shown in Figure 6. The SOURCE ID field includes identification information of the input device or medical device from where the data originates. The DESTINATION ID field includes
20 identification information identifying the input device or medical device that is to receive the data. The OPCODE

field defines the type of commands being transmitted. The
PRIORITY field defines the priority of the input device.
The priority data may be utilized to determine which input
device has control of the medical device. The SEQ # field
5 provides a packet sequence number so that the receiving
computer can determine whether the packet is out of
sequence.

The TX Rate field is the average rate at which packets
are being transmitted. The RX Rate field is the average
10 rate that packets are being received. The RS232 ACK field
includes an acknowledgement count for RS232 data. RS232
data is typically maintained within the queue of a computer
until an acknowledgement is received from the receiving
computer that the data has been received.

15 The RS232 POS field is a counter relating to
transmitted RS232 data. The RS232 ID field is an
identification for RS232 data. The RS232 MESS SZ field
contains the size of the packet. The RS232 BUFFER field
contains the content length of the packet. The DATA field
20 contains data being transmitted and may contain separate
subfields for robotic and RS232 data. CS is a checksum

field used to detect errors in the transmission of the packet.

Either computer 106 or 116 can be used as an arbitrator between the input devices and the medical devices. For example, the computer 116 may receive data from both consoles 102 and 104. The packets of information from each console 102 and 104 may include priority data in the PRIORITY fields. The computer 116 will route the data to the relevant device (eg. robot, instrument, etc.) in accordance with the priority data. For example, console 104 may have a higher priority than console 102. The computer 116 will route data to control a robot from console 104 to the exclusion of data from console 102 so that the surgeon at 104 has control of the arm.

As an alternate embodiment, the computer 116 may be constructed and configured to provide priority according to the data in the SOURCE ID field. For example, the computer 116 may be programmed to always provide priority for data that has the source ID from console 104. The computer 116 may have a hierarchical tree that assigns priority for a number of different input devices.

Alternatively, the computer 106 may function as the arbitrator, screening the data before transmission across the network 114. The computer 106 may have a priority scheme that always awards priority to one of the consoles 5 102 or 104. Additionally, or alternatively, one or more of the consoles 102 and 104 may have a mechanical and/or software switch that can be actuated to give the console priority. The switch may function as an override feature to allow a surgeon to assume control of a procedure.

10 In operation, the system initial performs a start-up routine. The ZEUS system is typically configured to start-up with data from the consoles. The consoles may not be in communication during the start-up routine of the robotic arms, instruments, etc. during the start-up routine so that 15 the system does not have the console data required for system boot. The computer 116 may automatically drive the missing console input data to default values. The default values allow the patient side of the system to complete the start-up routine. Likewise, the computer 106 may also 20 drive missing incoming signals from the patient side of the system to default values to allow the consoles 102 and/or

104 to boot-up. Driving missing signals to a default value may be part of a network local mode. The local mode allows one or more consoles to "hot plug" into the system without shutting the system down.

5 Additionally, if communication between the surgeon and patient sides of the system are interrupted during operation the computer 106 will again force the missing data to default values. The default values may be quiescent signal values to prevent unsafe operation of the
10 system. The components on the patient side will be left at the last known value so that the instruments and arms do not move.

 Once the start-up routines have been completed and the communication link has been established the surgeons can
15 operate the consoles. The system is quite useful for medical procedures wherein one of the surgeons is a teacher and the other surgeon is a pupil. The arbitration function of the system allows the teacher to take control of robot movement and instrument actuation at anytime during the
20 procedure. This allows the teacher to instruct the pupil

on the procedure and/or the use of a medical robotic system.

Additionally, the system may allow one surgeon to control one medical device and another surgeon to control the other device. For example, one surgeon may move the instruments 22 and 24 while the other surgeon moves the endoscope 32, or one surgeon may move one instrument 22 or 24 while the other surgeon moves the other instrument 24 or 22.

Figure 7 shows an alternate embodiment, wherein one or more of the consoles 102 and 104 has an alternate communication link 160. The alternate link may be a telecommunication network that allows the console 102 to be located at a remote location while console 104 is in relative close proximity to the robotic arms, etc. For example, console 102 may be connected to a public phone network, while console 104 is coupled to the controller 118 by a LAN. Such a system would allow telesurgery with the robotic arms, instruments, etc. The surgeon and patient sides of the system may be coupled to the link 160 by network computers 162 and 164.

While certain exemplary embodiments have been described and shown in the accompanying drawings, it is to be understood that such embodiments are merely illustrative of and not restrictive on the broad invention, and that this invention not be limited to the specific constructions and arrangements shown and described, since various other modifications may occur to those ordinarily skilled in the art.

CLAIMS

1. A medical system, comprising:
 - a first medical device;
 - a first input device that can control said first medical device;
 - a second input device that can control said first medical device; and
 - an arbitrator that allows either said first input device or said second input device to control said first medical device, wherein said first and second input devices each transmit a packet of information, each packet including an indication that is used by said arbitrator to allow either said first input device or second input device to control said first medical device.
2. The system of claim 1, wherein said first medical device includes a robotic arm.
3. The system of claim 2, wherein said first medical device includes an instrument.
4. The system of claim 1, wherein said first input device includes a console that has a video screen and a handle.
5. The system of claim 1, wherein said second input device includes a console that has a video screen and a handle.
6. The system of claim 1, wherein said second input device includes a touchpad screen.

7. The system of claim 1, wherein the indication is a priority.

8. The system of claim 1, wherein the indication is a source address.

9. The system of claim 1, wherein said arbitrator includes a computer.

10. The system of claim 1, further comprising a communication link that couples said first and second input devices with said first medical device.

11. The system of claim 10, further comprising:
a second medical device; and
a third input device that can control said second medical device.

12. The system of claim 11, wherein said first medical device includes a medical instrument and a robotic arm that moves said medical instrument; and said second medical device includes a camera, and endoscope coupled to said camera, and a robotic arm that moves said endoscope.

13. The system of claim 12, further comprising a communication link that couples said first and second medical devices with said first and second input devices, and a computer that multiplexes robotic data from said robotic arms with video data from said camera onto said communication link.

14. A medical system, comprising:
a first medical device;
first input means for controlling said first medical device;
second input means for controlling said first medical device; and
arbitrator means for allowing either said first input means or said second input means to control said first medical device, wherein said first and second input means each transmit a packet of information, each packet including an indication that is used by said arbitrator means to allow either said first input means or second input means to control said first medical device.

15. The system of claim 14, wherein said first medical device includes a robotic arm.

16. The system of claim 15, wherein said first medical device includes an instrument.

17. The system of claim 14, wherein said first input means includes a console that has a video screen and a handle.

18. The system of claim 14, wherein said second input means includes a console that has a video screen and a handle.

19. The system of claim 14, wherein said second input means includes a touchpad screen.

20. The system of claim 14, wherein the indication is a priority.

21. The system of claim 14, wherein the indication is a source address.

22. The system of claim 14, wherein said arbitrator means includes a computer.

23. The system of claim 14, further comprising communication means for coupling said first and second input means with said first medical device.

24. The system of claim 23, further comprising:
a second medical device; and
a third input means for controlling said second medical device.

25. The system of claim 24, wherein said first medical device includes a medical instrument and a robotic arm that moves said medical instrument; and said second medical device includes a camera, an endoscope coupled to said camera, and a robotic arm that moves said endoscope.

26. The system of claim 25, further comprising communication means for coupling said first and second medical devices with said first and second input means, and multiplexor means for multiplexing robotic data from said robotic arms with video data from said camera onto said communication means.

27. A medical system, comprising:
a first robotic arm;
a first medical instrument coupled to said first robotic arm;
a second robotic arm;

a second medical instrument coupled to said second robotic arm;

a third robotic arm that can hold an endoscope coupled to a camera;

a first console that can control said first and second robotic arms;

a second console that can control said first and second robotic arms;

a first endoscopic input device that can control said third robotic arm;

a second endoscopic input device that can control said third robotic arm;

an arbitrator coupled to said first robotic arm, said second robotic arm, said third robotic arm, said first console, said second console, said first endoscopic input device and said second endoscopic input device, wherein said first and second consoles each transmit a packet of information to said arbitrator, the packet of information including an indication used by said arbitrator to determine whether said first and second robotic arms are to be controlled by said first console or said second console.

28. The system of claim 27, wherein the indication is a priority.

29. The system of claim 27, wherein the indication is a source address.

30. The system of claim 27, further comprising a communication link coupled to said arbitrator and said first and second consoles, said arbitrator multiplexes robotic data from said first, second and third robotic arms

with video data from the camera onto said communication link.

31. A medical system, comprising:

- a first robotic arm;
- a first medical instrument coupled to said second robotic arm;
- a second robotic arm;
- a second medical instrument coupled to said second robotic arm;
- a third robotic arm that can hold an endoscope coupled to a camera;
- a first console that can control said first and second robotic arms;
- a second console that can control said first and second robotic arms;
- a first endoscopic input device that can control said third robotic arm, said first endoscopic input device associated with said first console;
- a second endoscopic input device that can control said third robotic arm, said second endoscopic input device associated with said second console;

arbitrator means for allowing said first and second robotic arms to be controlled by either said first console or said second console, and said third robotic arm to be controlled by either said first endoscopic input device or said second endoscopic input device, wherein said first and second consoles each transmit a packet of information including an indication to said arbitrator means, said indication used by said arbitrator means to determine whether said first and second robotic arms are to be controlled by said first console or second console and whether said third robotic arm is to be controlled by said

first endoscopic input device or said second endoscopic input device.

32. The system of claim 31, wherein the indication is a priority.

33. The system of claim 31, wherein the indication is a source address.

34. The system of claim 31, further comprising communication means for coupling said arbitrator means with said first and second consoles, said arbitrator means multiplexes robotic data from said first, second and third robotic arms with video data from the camera onto said communication means.

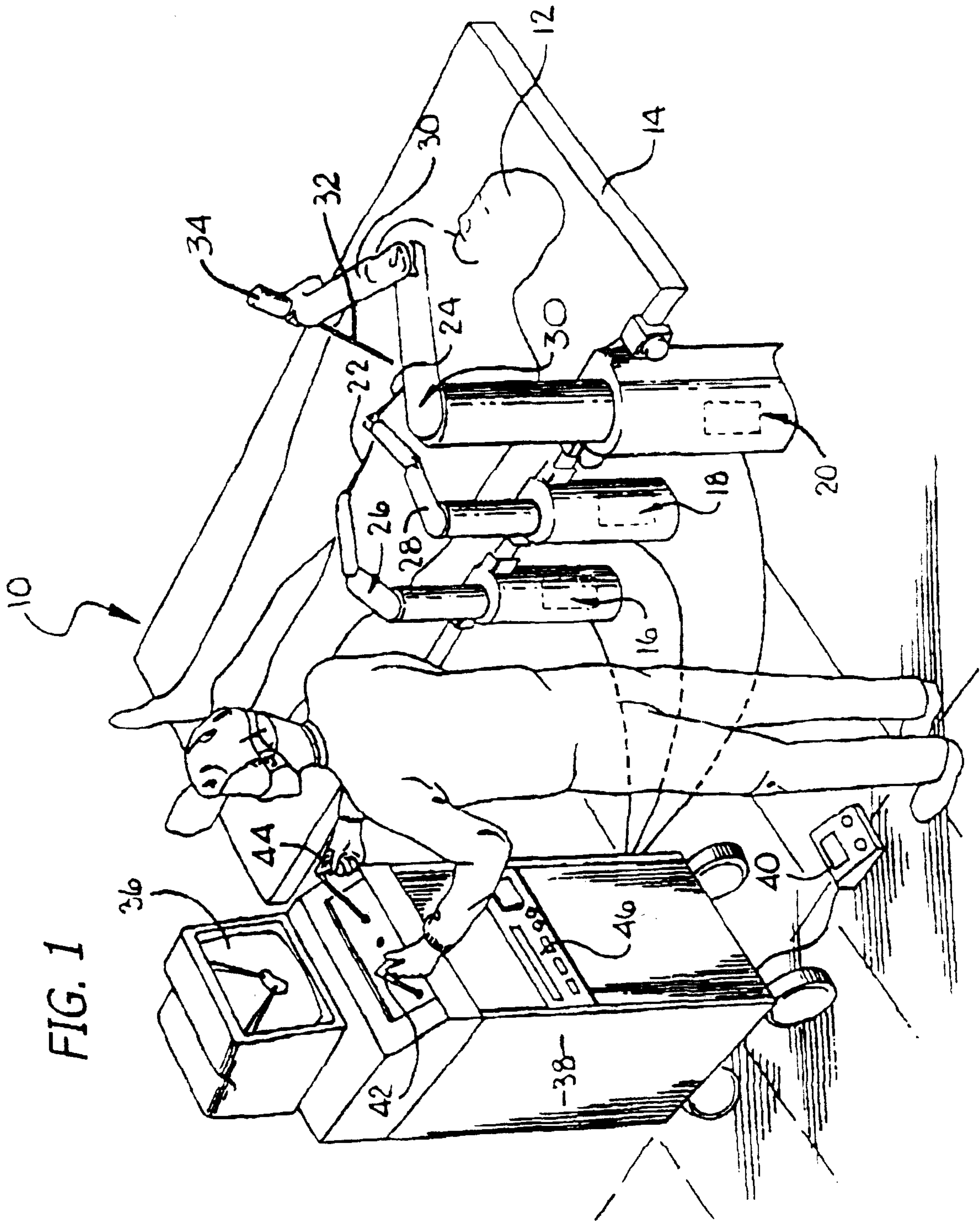

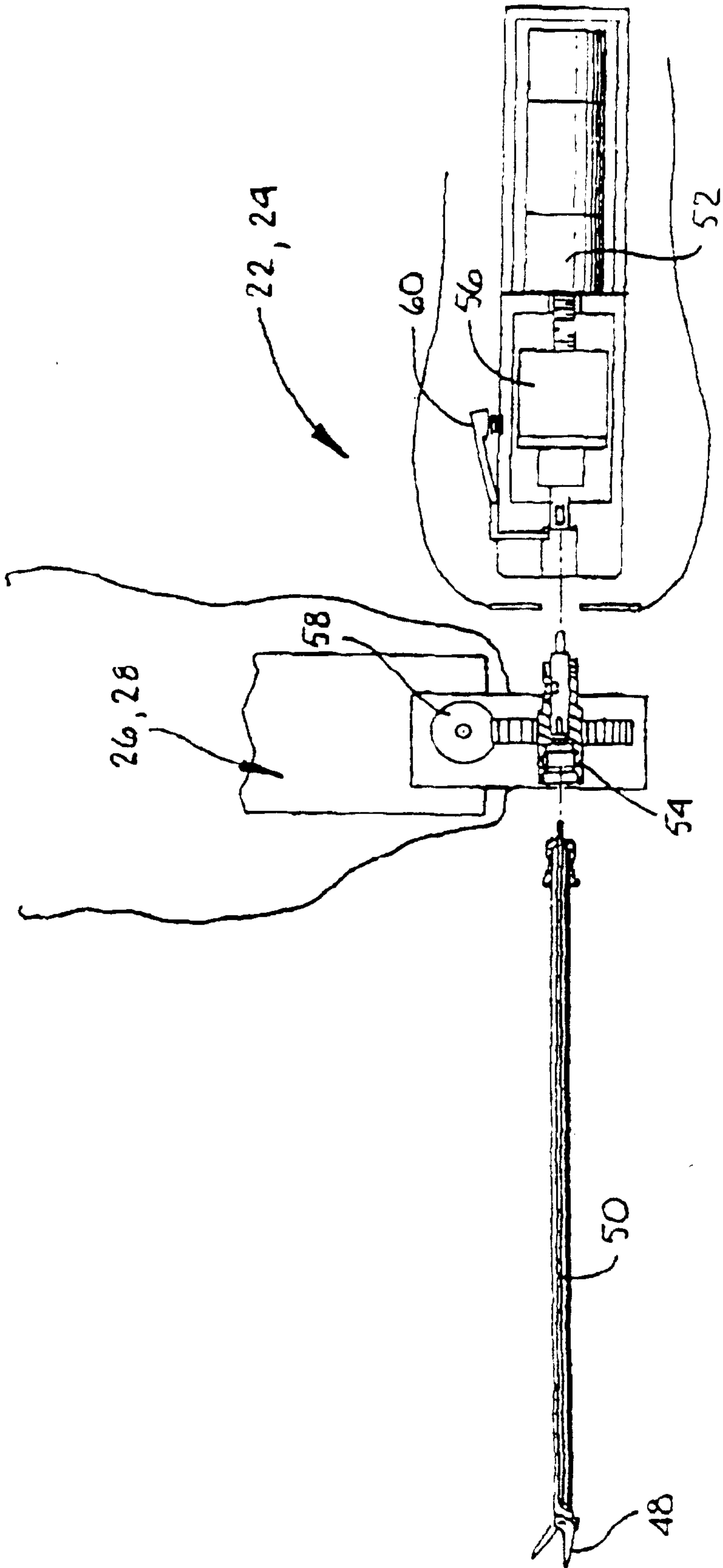

FIG. 2

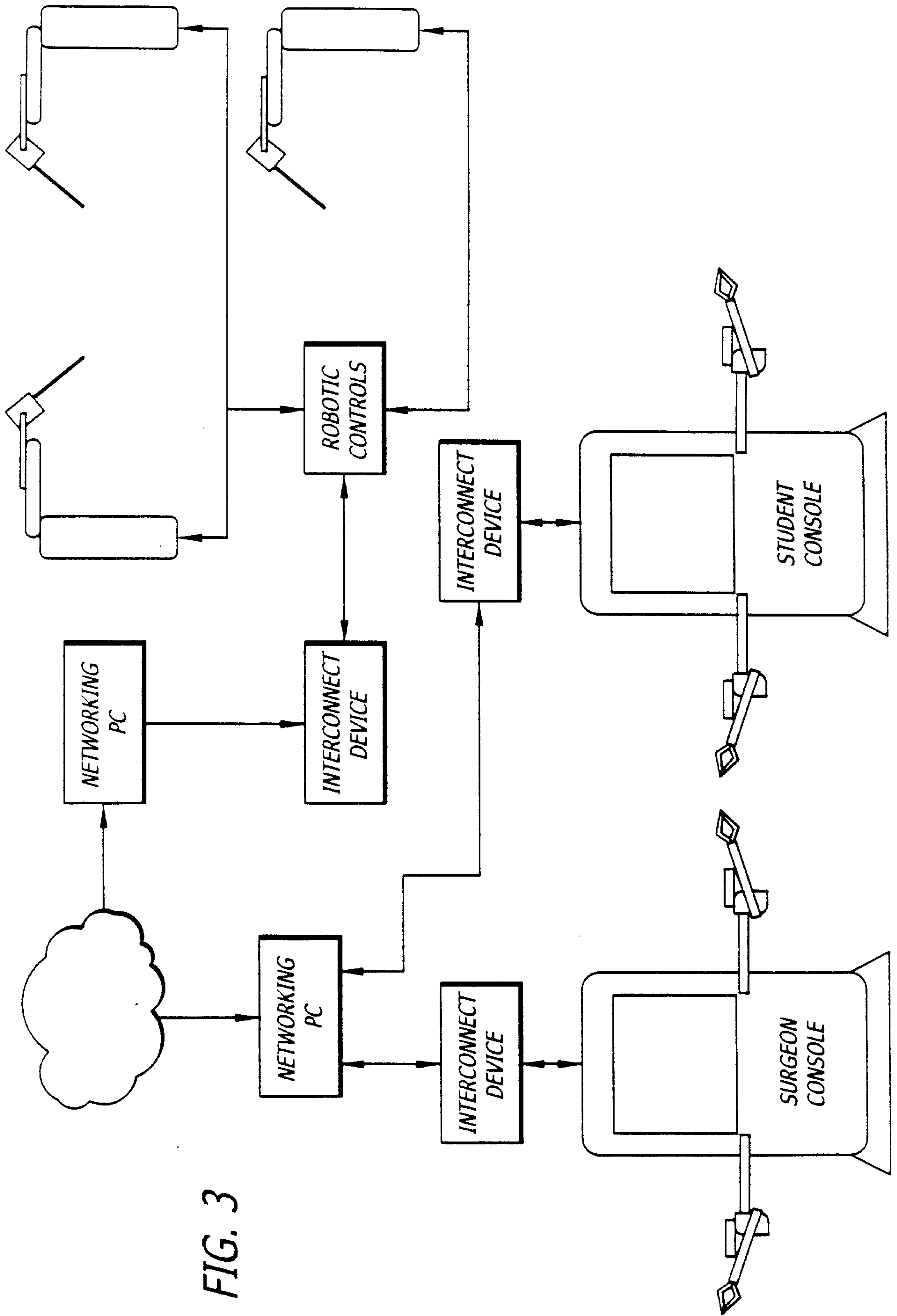
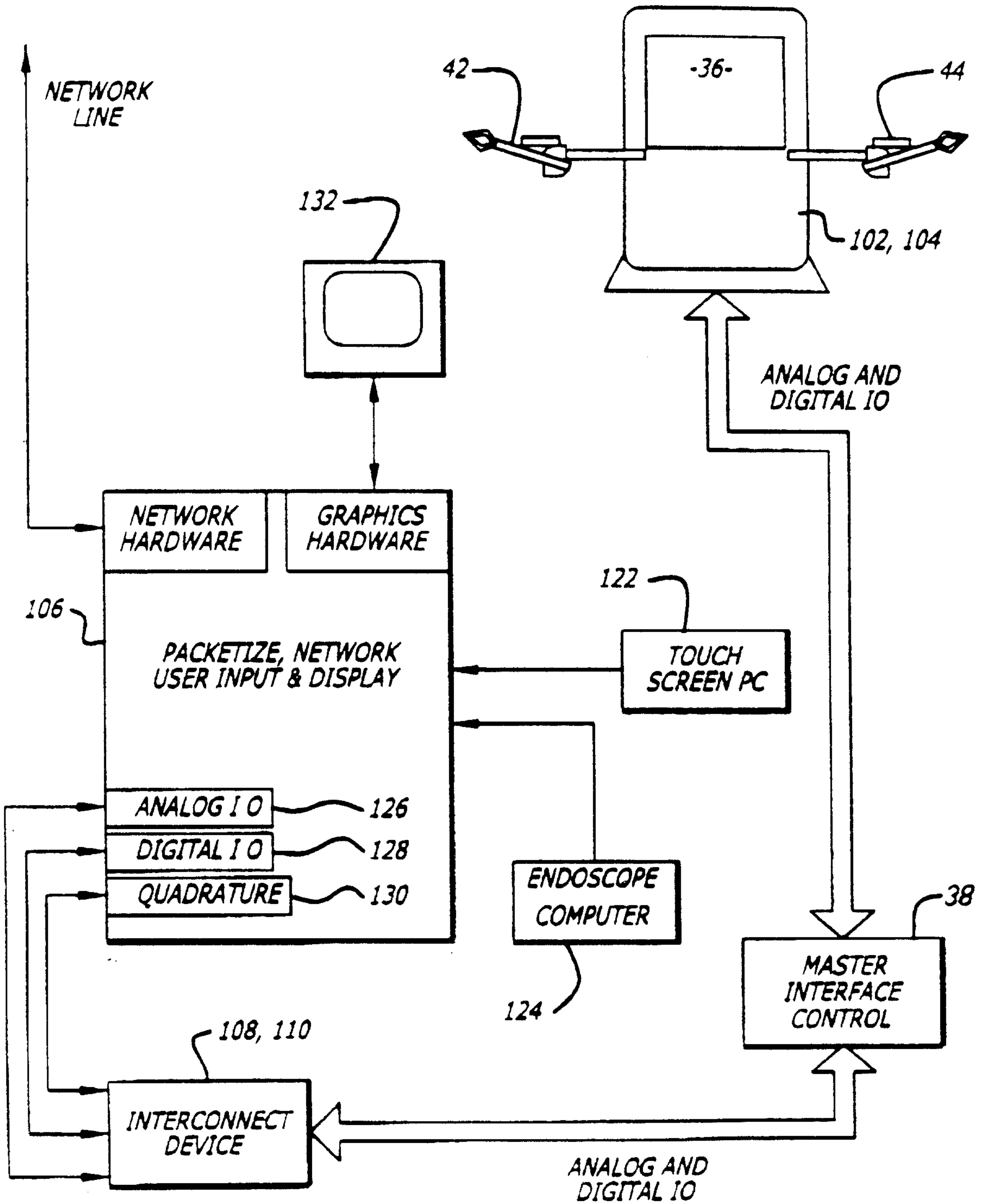

FIG. 3

FIG. 4



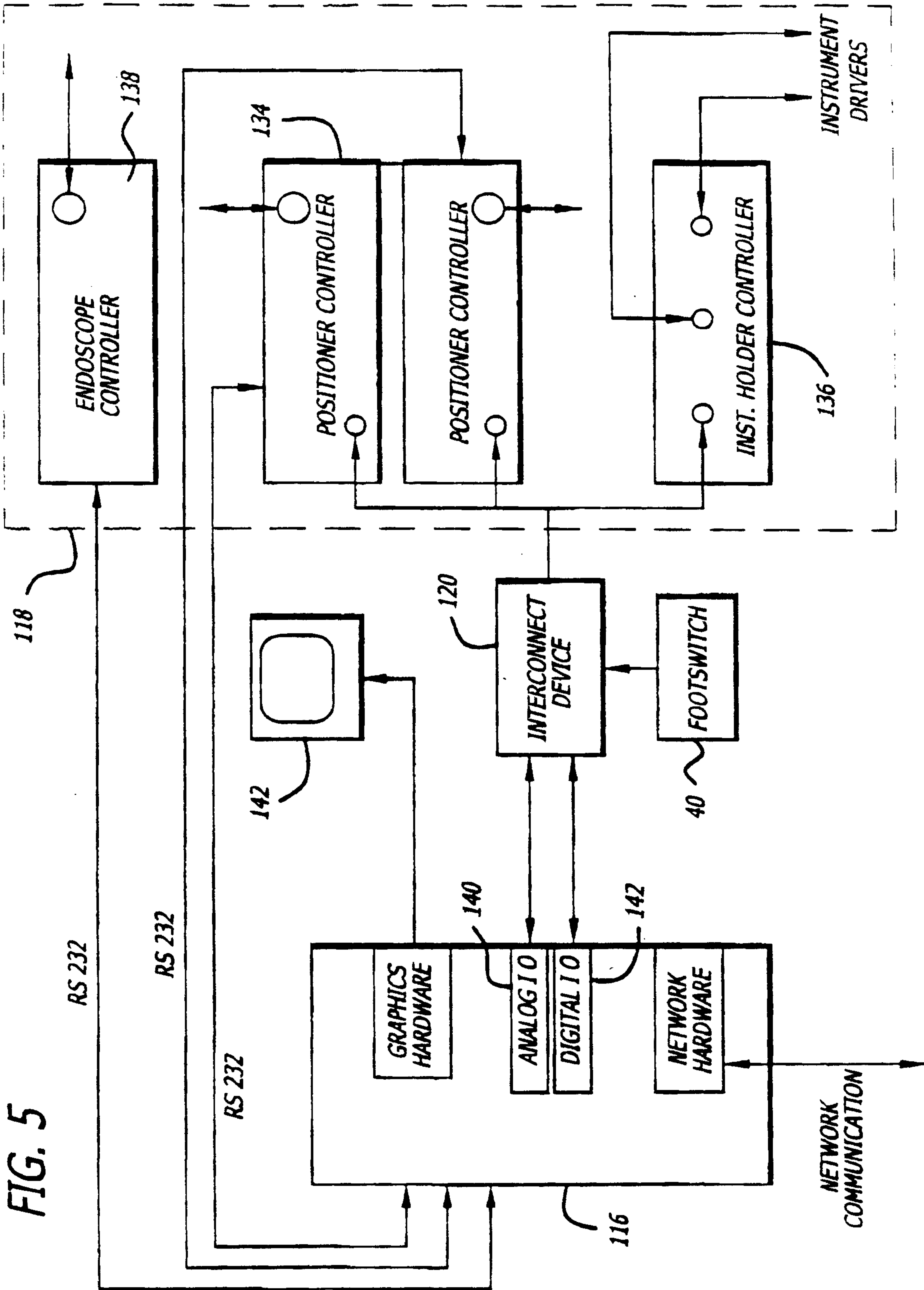
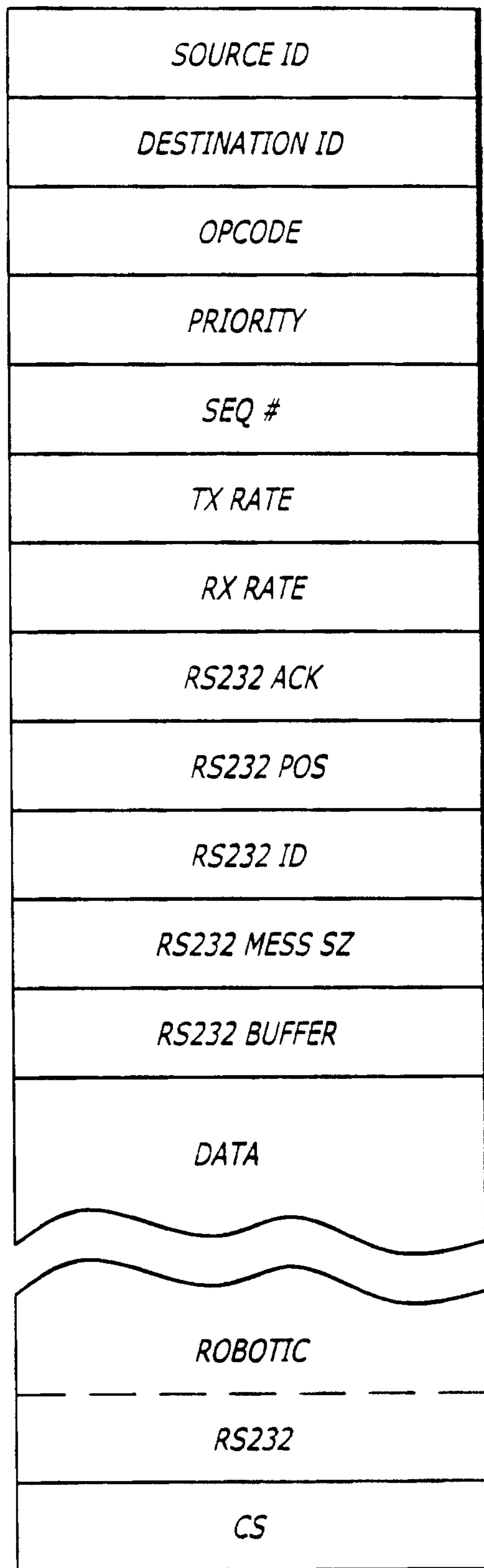
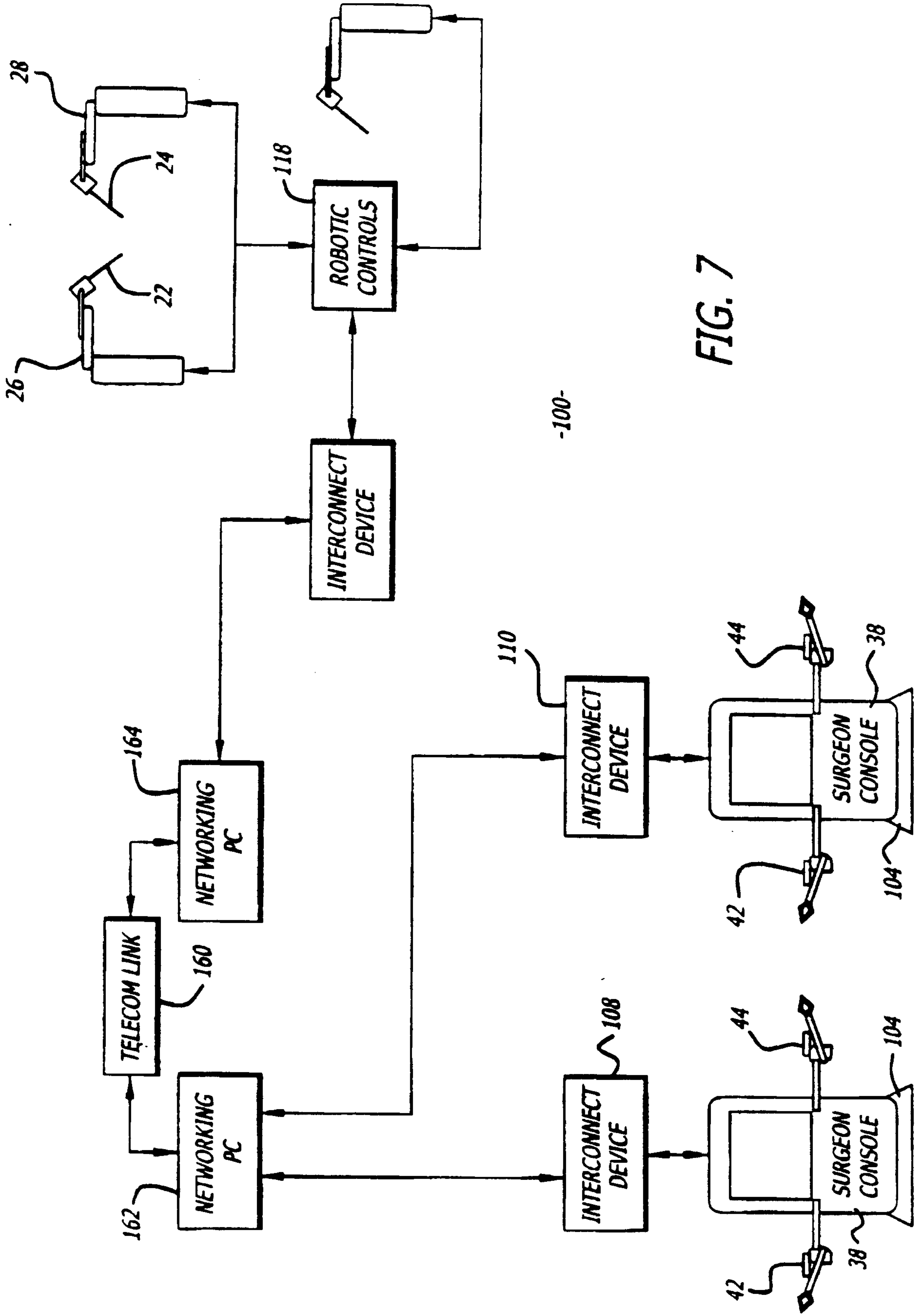

FIG. 5

FIG. 6





-100-

FIG. 7

