

EUROPEAN PATENT APPLICATION

Application number: 82106909.3

Int. Cl.³: **B 66 F 9/075**
B 66 F 9/19, B 66 F 9/12

Date of filing: 30.07.82

Priority: 14.08.81 NL 8103818

Date of publication of application:
02.03.83 Bulletin 83/9

Designated Contracting States:
AT BE CH DE FR GB IT LI LU NL SE

Applicant: **Selectiebedrijf Kooi Beheer B.V.**
No. 25, Molen
NL-9077 ZV Vrouwenparochie(NL)

Inventor: **Hessel, Kooi**
Stienser Hogedijk 38a
Stiens(NL)

Representative: **Hojtink, Reinoud et al,**
OCTROOIBUREAU ARNOLD & SIEDSMA Isartorplatz 5
D-8000 München 2(DE)

Fork lift truck with reversing device.

Device (5) for removing a load placed on a pallet (21) from a fork lift truck. The device (5) can be mounted on the mast (6) of an existing fork lift truck and is provided to this end with means for co-operating with the guide means along said mast (6) and means (17, 18, 19) for turning the device (5) through at least 180° with respect to the mast (6). Apart from a frame (9) having protruding carrying forks (3) a second frame (7) having clamping forks (10) is provided. The two frames (9, 7) are relatively movable in order to clamp the load between the carrying forks (3) and the clamping forks (10). There is furthermore provided a shifting device (13) for shifting the load from the forks (10). The frame (9) for the carrying forks (3) and the shifting device (13) in the retracted position are located within the first frame (9) so that a very restricted length of the front structure is obtained.

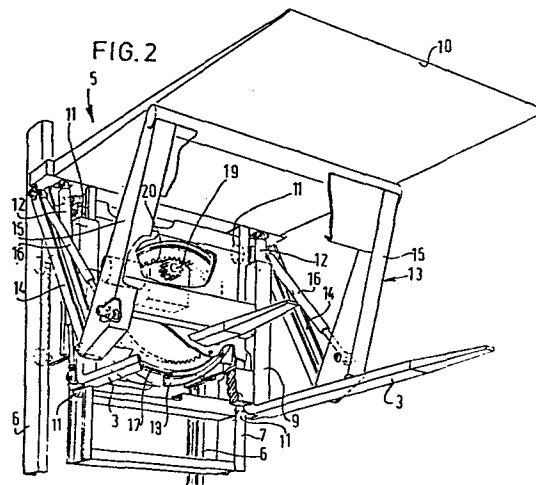

-1-

Fork lift truck with reversing device

The invention relates to a device to be mounted to the mast of a fork lift truck comprising means for co-operating with guide means along the mast, means for turning the device through at least 180° with respect to the mast, a first
5 vertical frame having protruding carrying forks and a second frame spaced apart from the first frame and having protruding clamping forks, the first frame being vertically movable with respect to the second frame, and a locking device movable between the forks in the direction of length of the
10 forks.

Such a known device is mounted on the mast of the fork lift truck and serves to discharge a load transported on a pallet so that the pallet can be taken back. To this end the load transported on a pallet is clamped by the vertical
15 movement of the first frame between the forks of the first and the second frame, the whole device being then turned through 180° with respect to the mast, the clamp and the carrying fork being moved slightly away from one another, whilst finally with the aid of the shifting device the load
20 is shifted from the clamping forks onto the deposition surface. The pallet then remains on the carrying forks.

The known device is not adapted to be mounted on the fork lift truck transportable on a van. With this construction of the assembly the part protruding from the rear side
25 of the van is too large so that the provisions of safety can no longer be satisfied. The invention has for its object to

render the known device suitable for mounting on a transportable fork lift truck.

According to the invention this is achieved in that the beams of the second frame are arranged in the same
5 vertical plane as those of the first frame and the shifting device is formed by a pivotal lever, which is also located in said vertical plane in the retracted position.

By the steps taken in accordance with the invention a very compact construction is obtained so that despite the
10 presence of the device the extension of the part of the fork lift truck protruding from the rear side of the van can be drastically reduced, that is to say, in practice to about 240 mms.

In one embodiment an arm of the pivotal leverage is
15 pivotally journalled in a beam of the first frame. The movement of the first frame can be guided in the second frame. Since the second frame is rotatable with respect to the mast, the whole device is rotatable with respect to the mast.

The invention will be described more fully with reference
20 to the drawings.

The drawings show in:

Fig. 1 a schematic side elevation of a fork lift truck transportable on a van with a device embodying the invention.

Fig. 2 a perspective view of part of the device embodying
25 the invention,

Fig. 3 a sectional view of the device embodying the invention with a shifting device partly slipped out and

Fig. 4 a sectional view of the device embodying the invention in the retracted position.

On a van 1 (shown partly) can be deposited a fork lift
30 truck of known type by slipping the carrying forks 3 into the appropriate beam 4 and by subsequently causing the frame of the fork lift truck to move upwards. The device 5 embodying the invention can be mounted on this known, transportable
35 fork lift truck.

The device 5 is mounted on the mast 6 of the transportable fork lift truck. The device 5 embodying the invention comprises a first frame 9 of vertical and horizontal beams, from which protrude carrying forks 3. The device 5

-3-

furthermore comprises a second, vertical frame 7, from which protrude the clamping forks formed in this case by a plate 10. By means of guide rollers 11 the first frame can be vertically guided in the second frame 7. In its vertical movement the first frame is controlled by hydraulic means, for example, a plunger 12. With the first frame is connected a shifting device 13 formed by a pivotal leverage comprising the arms 14 and 15. The leverage is controlled, for example, by a hydraulic or pneumatic plunger 16. With respect to the mast the second frame 7 can be reversed, since it is adapted to rotate by a shaft 17 in a hub 18. The movement of the frame and hence of the whole device is performed by the rolling movement of a driving gear wheel 19 on the inner toothing 20 of the shaft 17.

The device operates as follows: The carrying forks 3 of the first frame are slipped into a pallet 21, on which a load is deposited. Subsequently, with the aid of the plungers 12, the carrying forks 3 are lifted until the load rests on the clamping forks 10. Then with the aid of the reversing mechanism 17, 18, 19 and 20 the device embodying the invention is turned through 180° so that the position shown in Fig. 3 is obtained. Then the first frame is moved vertically upwards so that the load is set free of the pallet 21 and bears on the clamping forks 10. Then with the aid of the plunger 16 the shifting device 13 is actuated so that the load is slipped in the direction indicated in Fig. 3 from the clamping forks 10 onto a deposition surface, for example, 22. Subsequently the device is again turned and the pallet can be deposited back on the van. Owing to the compact construction in accordance with the invention the added length of the transportable fork lift truck 23 (see Fig. 4) is limited to about 240 mms.

-1-

CLAIMS

1. A device adapted to be mounted on the mast of a fork lift truck comprising means for co-operating with the guide means along the mast, means for turning the device through at least 180° with respect to the mast, a first, vertical
5 frame having protruding carrying forks and a second frame spaced apart from the first frame and having protruding clamping forks, whilst the first frame is vertically movable with respect to the second frame, and a shifting device adapted to move between the forks in the
10 direction of length of the forks characterized in that the beams of the second frame are located in the same vertical plane as those of the first frame and the shifting device is formed by a pivotal leverage, which is also located in said vertical plane in the retracted position.

15 2. A device as claimed in claim 1 characterized in that one arm of the pivotal leverage is pivotally journalled in a beam of the first frame.

3. A device as claimed in claims 1 and 2 characterized in that the first frame is guided in the second frame.

20 4. A device as claimed in claims 1 to 3 characterized in that the second frame is rotatable with respect to the mast.

FIG. 1

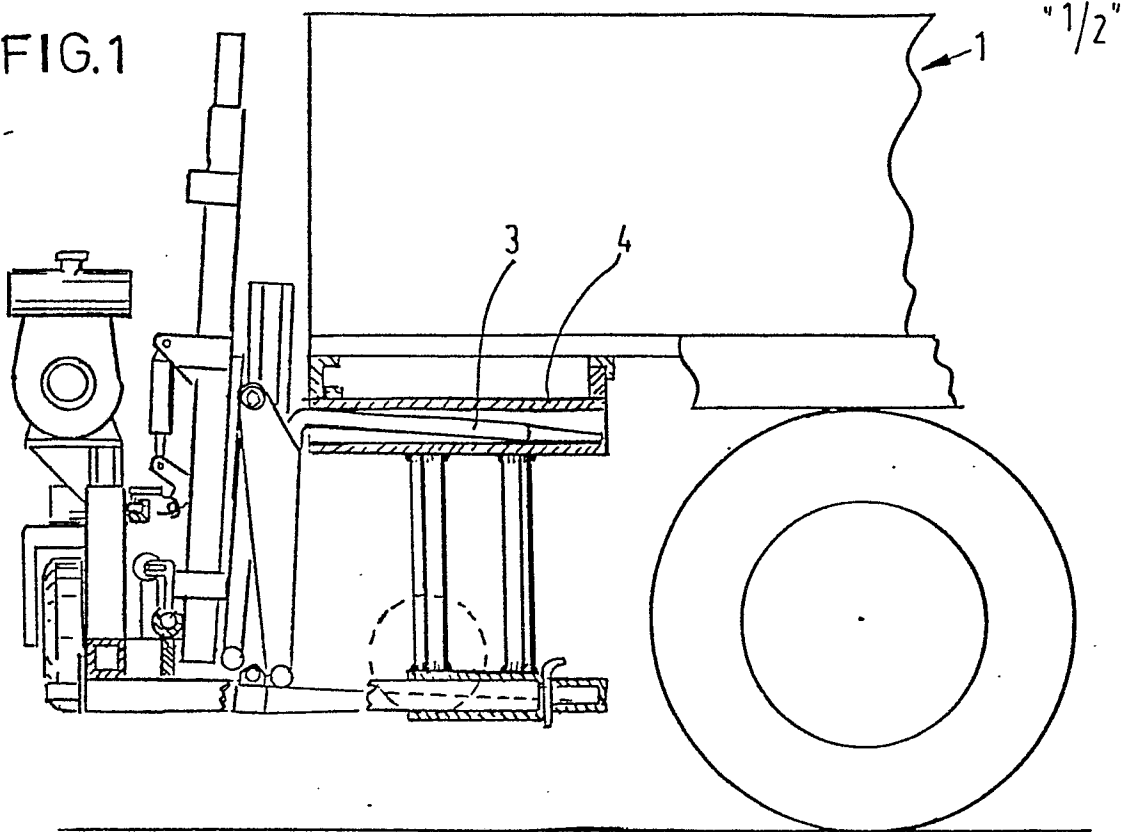
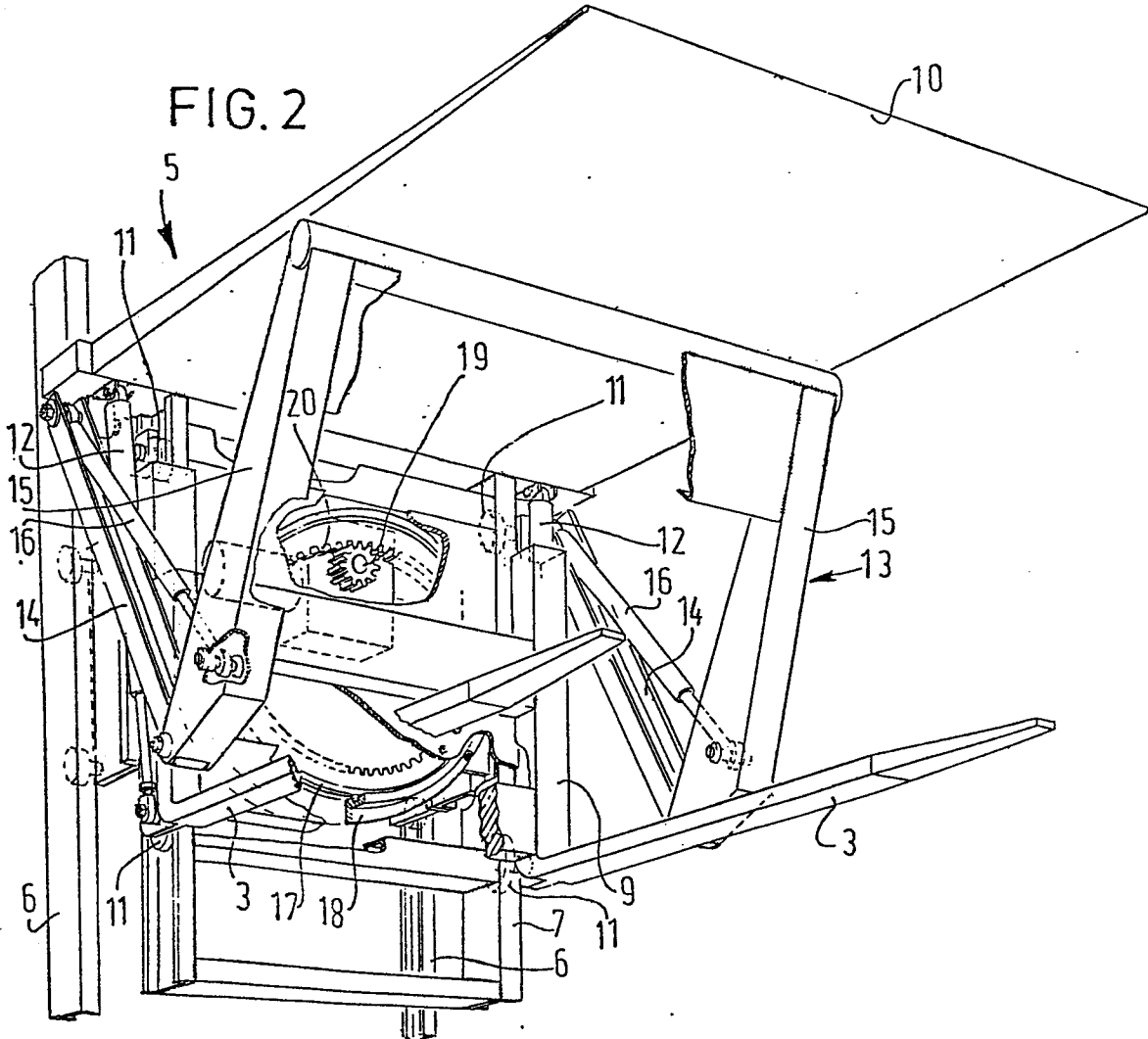

FIG. 2



"2/2"

FIG. 3

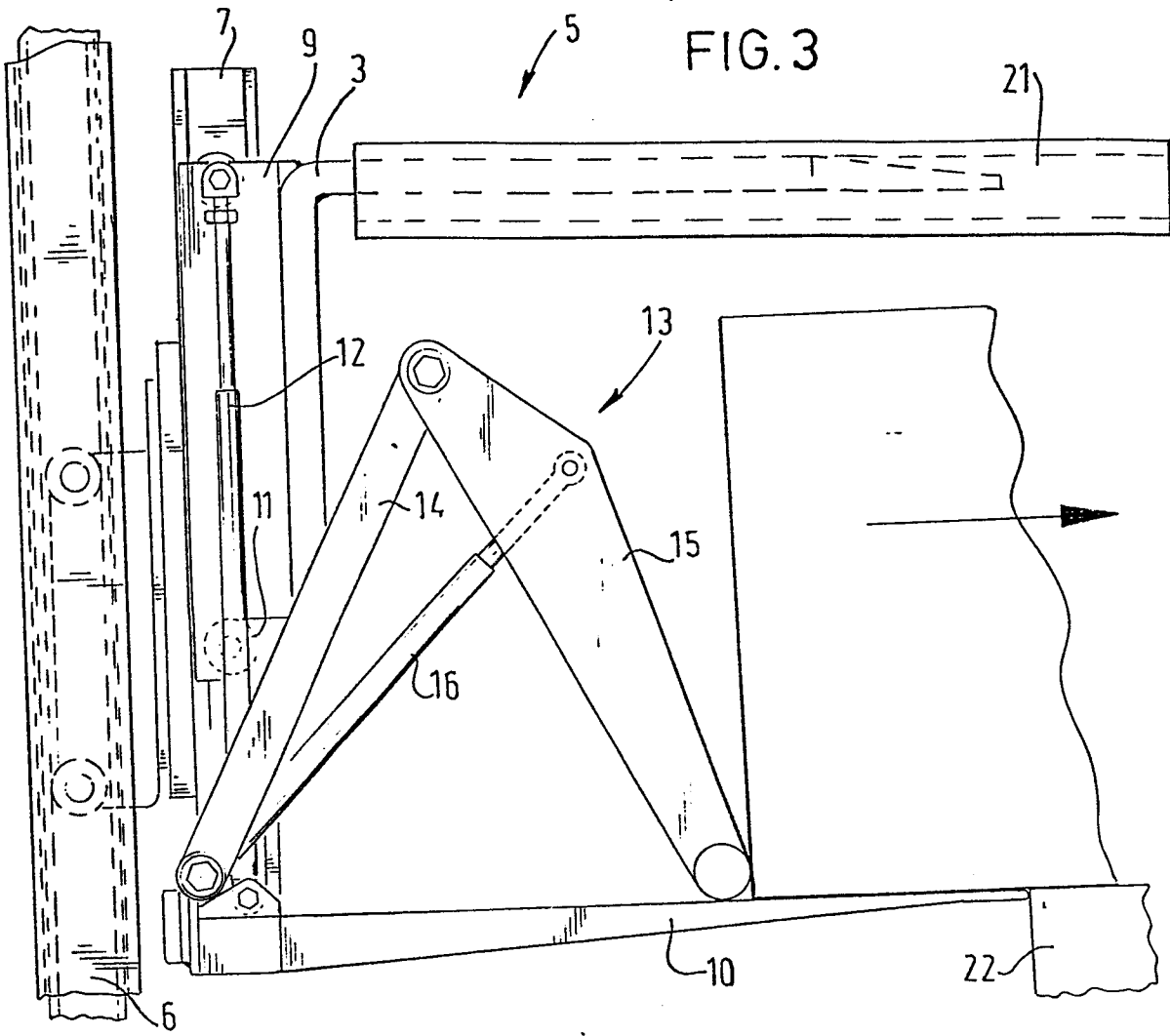
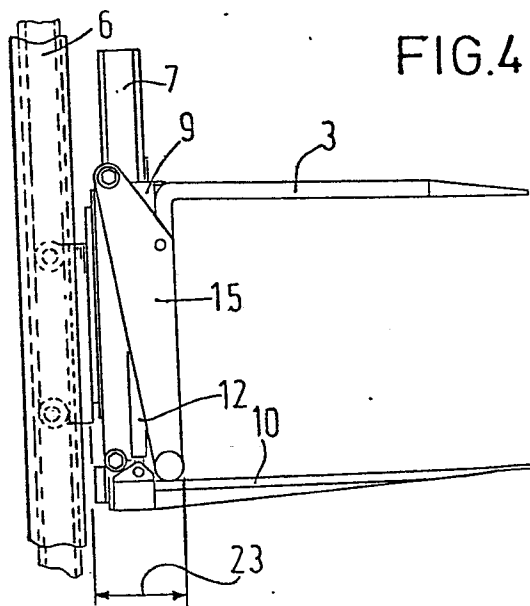

FIG. 4





DOCUMENTS CONSIDERED TO BE RELEVANT			
Category	Citation of document with indication, where appropriate, of relevant passages	Relevant to claim	CLASSIFICATION OF THE APPLICATION (Int. Cl. 3)
X	<p style="text-align: center;">---</p> US-A-3 438 525 (NUTTER) * Whole document *	1-4	B 66 F 9/075 B 66 F 9/19 B 66 F 9/12
A	<p style="text-align: center;">---</p> GB-A-1 066 129 (WINTER)		
A	<p style="text-align: center;">---</p> US-A-2 468 326 (GLEASON)		
A	<p style="text-align: center;">---</p> GB-A-1 582 559 (PAYNE)		
A	<p style="text-align: center;">---</p> US-A-4 268 210 (FERGUSON)		
	-----		TECHNICAL FIELDS SEARCHED (Int. Cl. 3)
			B 66 F
The present search report has been drawn up for all claims			
Place of search THE HAGUE		Date of completion of the search 17-11-1982	Examiner VAN DEN BERGHE E.J.J
CATEGORY OF CITED DOCUMENTS X : particularly relevant if taken alone Y : particularly relevant if combined with another document of the same category A : technological background O : non-written disclosure P : intermediate document		T : theory or principle underlying the invention E : earlier patent document, but published on, or after the filing date D : document cited in the application L : document cited for other reasons & : member of the same patent family, corresponding document	