

[54] UNIVERSAL HANDLE FOR SURGICAL IMPLEMENTS

[76] Inventor: Anthony T. Rose, 603 Hudspeth Ave., Simi, Calif. 93065

[22] Filed: Feb. 7, 1972

[21] Appl. No.: 224,179

[52] U.S. Cl. 16/114 R, 30/339, 85/45, 128/312, 151/37

[51] Int. Cl. ... A47j 45/10, A61b 17/16, F16b 23/00

[58] Field of Search 128/305, 312; 30/168, 329, 30/335-339; 145/24; 56/300; 16/114 R, 114 A, 114; 294/57, 58; 85/45, 48; 151/37, 39

[56] **References Cited**

UNITED STATES PATENTS

81,044	8/1868	Whiteley.....	151/39
366,432	7/1887	Schwab.....	16/114 R
798,127	8/1905	Burnitt.....	16/114 R
884,290	4/1908	Montes.....	151/39
2,800,089	7/1957	Seils.....	16/114 R
2,800,829	7/1957	West.....	85/45
3,316,605	5/1967	Tabbert.....	24/277

3,424,212	1/1969	Kemper.....	85/45 X
1,529,683	3/1925	Anderson.....	145/24
2,305,465	12/1942	Bangser.....	30/339 X
493,054	3/1893	Bassford.....	56/300
1,934,962	11/1933	Barry.....	128/312

FOREIGN PATENTS OR APPLICATIONS

107,433	3/1925	Switzerland.....	145/24
---------	--------	------------------	--------

Primary Examiner—Donald A. Griffin
Attorney, Agent, or Firm—Robert E. Geauque

[57] **ABSTRACT**

A surgical chisel apparatus wherein the chisel head is removable with respect to the handle, the connecting end of the handle is bifurcated forming a pair of non-parallel spaced apart legs, a fastener to bind together the legs into a pivotal relationship about the mating end of the chisel head, thereby effecting secure retention of the mating head in cooperation with the connecting end. A hammer can be incorporated within the chisel handle. A novel wrench is employed to operate the fastener.

13 Claims, 7 Drawing Figures

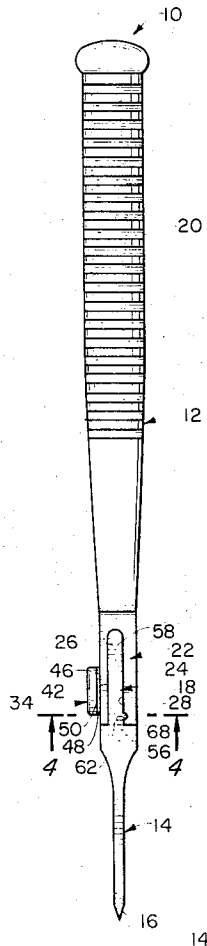

Fig. 1.

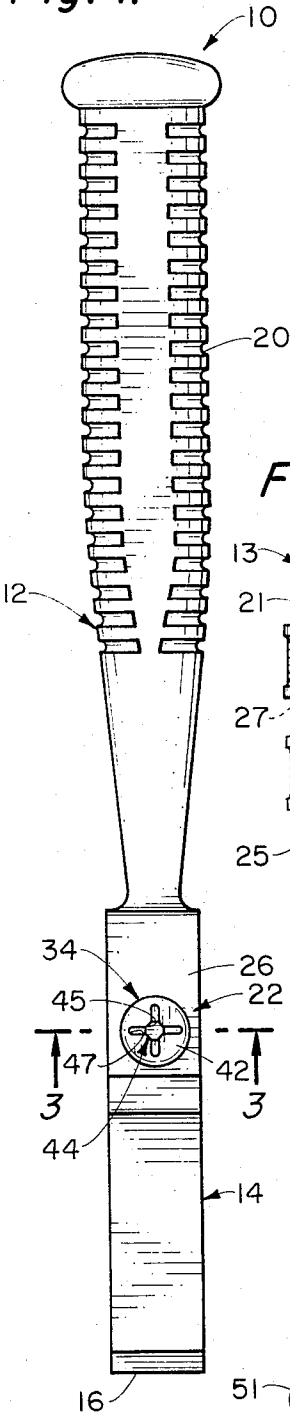

Fig. 2.

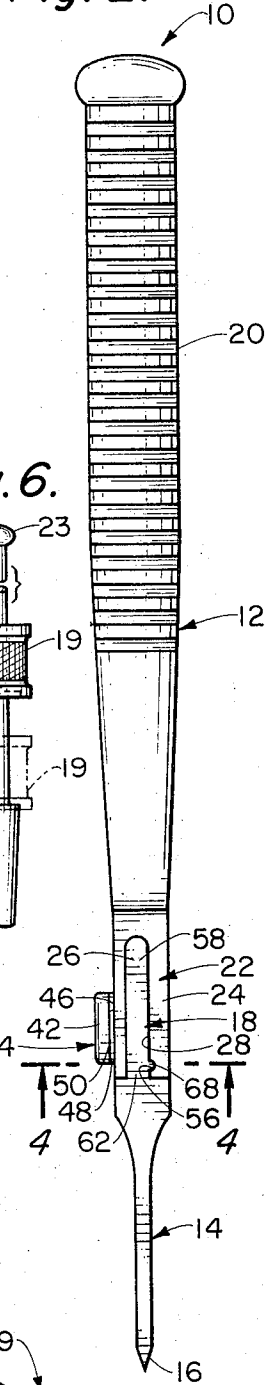

Fig. 3.

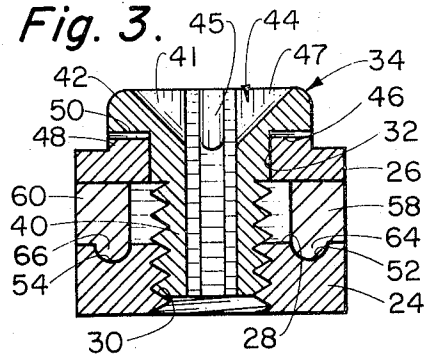

Fig. 4.

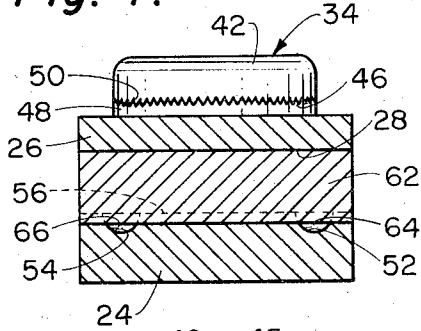

Fig. 5.

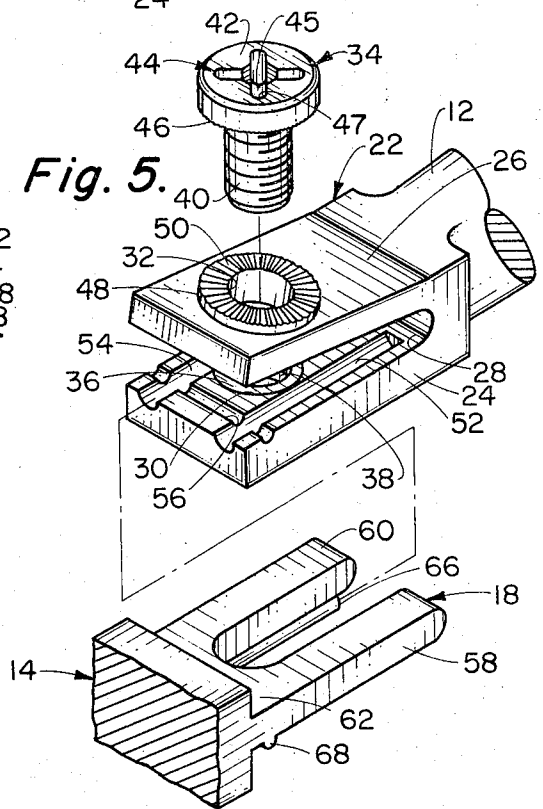
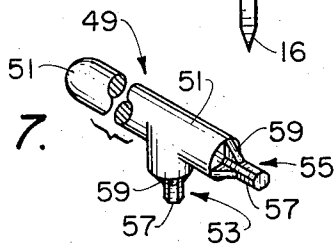

Fig. 7.



UNIVERSAL HANDLE FOR SURGICAL IMPLEMENTS

BACKGROUND OF THE INVENTION

The field of this invention relates to a replaceable blade structure for a tool and more particularly a replaceable blade for a chisel which is to be employed in the intended environment of medical surgery. The term chisel used herein is intended to include osteomes, gauges, elevators and curvettes.

Surgical instruments must be formed of an extremely hard metallic material which can be frequently autoclaved in order to make such instruments sanitary. The surgical chisel must be entirely formed of this hard material which greatly adds to the weight of the chisel and the manufacturing cost thereof. The most common type of material of construction of such chisels is stainless steel. The hardness of stainless steel is retained during the frequent autoclaving and also the stainless steel will hold a sharp edge for greater length of time.

Chisels are usually employed in surgery to remove slivers or chips of bone. This removal of bone must be accomplished with a high degree of precision. Therefore, it is required that the edge of the chisel be as sharp as possible.

Previously the chisel head and the handle of the chisel were an integral unit. Therefore, if the edge of the chisel needed to be sharpened, the entire chisel handle and the head must be removed from the hospital or clinic to be sharpened by a person skilled in the art of putting sharp edges on tools. This sharpening procedure may take several days which means that the tool would be unavailable for use during this period of time.

This procedure is extremely undesirable because as surgical chisels are formed of stainless steel and manufactured with a high degree of precision, such chisels are quite expensive. Heretofore, the common practice has been to actually purchase two chisels of each type, with one chisel being available for use and the other chisel being sharpened. As a result, each hospital had to incur a double expense in order to insure that there would be a sharp chisel available at all times.

SUMMARY OF THE INVENTION

This invention relates to the forming of a chisel where the chisel head is removably secured to the chisel handle. The connecting end of the chisel handle is bifurcated into a first leg and a second leg. The first leg is of a greater thickness than the thickness of the second leg. The first leg is located substantially parallel to the elongated axis of the handle. The second leg is formed slightly non-parallel to the elongated axis of the handle. Each of the legs includes an aperture which is in alignment to facilitate cooperation with a screw fastener. The first leg also includes a series of grooves. The mating end of the chisel head includes a pair of spaced apart prongs. The prongs of the mating end are to cooperate about the fastener between the legs of the bifurcated connecting end of the handle. The mating end also includes a plurality of protuberances which are to cooperate with the grooves formed in the connecting end. About the head of the fastener are formed a plurality of serrations. Upon the outer surface of the second leg is formed a similar series of serrations. The serrated surfaces of the head of the fastener and the second leg are to cooperate together to retain the fas-

tener in the tightened position, thereby preventing the chisel head from becoming loosely connected with respect to the handle during use. The head of the fastener includes a polygonal shaped recess with a plurality of slits extending therefrom. A wrench is to be employed to cooperate with the fastener head which includes both a polygonal shaped protuberance to cooperate with the recess and a plurality of spaced apart projections to cooperate with the slits. The chisel may also include a hammer incorporated into the handle thereby negating the use of a separate hammer. The blades are made to be disposable when such lose their sharpness or become otherwise unuseful.

BRIEF DESCRIPTION OF THE DRAWINGS

FIG. 1 is an overall longitudinal view of the chisel of this invention showing the removable chisel head retained upon the handle portion of the chisel;

FIG. 2 is a side view of the chisel of FIG. 1;

FIG. 3 is a cross-sectional view taken along line 3—3 of FIG. 1 showing more clearly the connection between the chisel head and the chisel handle;

FIG. 4 is a cross-sectional view of a portion of the connection of the chisel head to the chisel handle taken along line 4—4 of FIG. 2;

FIG. 5 is an exploded isometric view of the connection between the chisel head and the chisel handle;

FIG. 6 is a modification of the chisel of this invention which includes a hammer element slidably mounted upon the chisel handle; and

FIG. 7 is an isometric view of the wrench employed to cooperate with the head of the fastener to connect the chisel head to the handle.

DETAILED DESCRIPTION OF THE SHOWN EMBODIMENT

Referring particularly to the drawing, there is shown in FIG. 1 the chisel 10 of this invention basically composed of a handle 12 and a chisel head 14. The chisel head 14 is divided into a cutting blade 16 and a mating end 18. The handle 12 includes a grasping section 20 and a connecting end 22. The connecting end 22 is bifurcated so as to form a first leg 24 and a second leg 26. The bifurcation is inherently produced by the forming of the slot 28 which separates the first leg 24 and second leg 26.

Formed through the first leg 24 is a first aperture 30. Formed through the second leg 26 is a second aperture 32. Apertures 30 and 32 are to be in longitudinal alignment with each other so as to facilitate cooperation by a fastener 34. The aperture 30 is screw threaded. The fastener 34 includes external screw threads 40 which are to cooperate within the screw threaded opening 30. The fastener 34 also includes an enlarged head 42 which includes therein a recess assembly 44. Recess assembly 44 includes a central polygonal shaped recess 45 and a plurality of slits 47. The recess 45 preferably has eight sides. There are four in number of slits 47 equidistantly spaced apart with each slit 47 extending from the recess 45.

In FIG. 7 there is shown tool 49 which has a handle 51 and wrench heads 53 and 55. Heads 53 and 55 are both identical and permit the tool 49 to be used similarly to either a conventional screwdriver or wrench. Each head 53 and 55 includes an elongated polygonal shaped (eight sides preferable) protuberance 57. The protuberance 57 is to matingly cooperate with the re-

cess 45. Also each head 53 and 55 includes a plurality of projections 59 (four in number being preferable). These projections 59 are to matingly cooperate with the slits 47. As a result, a dual action wrenching effect is achieved through the use of both the protuberance 57 and the projections 59.

Located about the enlarged head 42 adjacent the threads 40 is an annular serrated surface 46. Extending above the surface of the second leg 26 is a boss 48 which also includes a serrated surface 50. Upon tightening of the fastener 34 within the aligned apertures 30 and 32, the serrated surfaces 46 and 50 cooperate in a frictional positive locking arrangement so as to prevent the fastener 34 from rotating with respect to the apertures 30 and 32.

It is to be noted that the thickness of the second leg 26 is substantially less than the thickness of the first leg 24. The reason for this will become more apparent further on in the description. Additionally, it is to be noted that the bifurcation is such so that the second leg 26 is located in a non-parallel relationship with the first leg 24. This non-parallel relationship is so that the spacing between the legs is larger at the opened end of the bifurcation than at the apex of the bifurcation. The reason for this will also be described further on in the specification.

Formed within the surface of the first leg 24 which is adjacent the slot 28 is a pair of spaced apart elongated grooves 52 and 54. The grooves 52 and 54 are located one on each side of the first aperture 30. Also located within the surface of the first leg 24 is a transverse groove 56. The transverse groove 56 crosses over each of the elongated grooves 52 and 54.

The mating end 18 is basically composed of a first prong 58 and a second prong 60. The first prong 58 and second prong 60 are connected together through a transverse section 62 which is located directly adjacent the blade 16 of the chisel. Integrally formed upon each of the prongs 58 and 60 is an elongated protuberance 64 and 66, respectively. Integrally formed transversely about section 62 is a transverse protuberance 68.

The operation of the chisel 10 of this invention is as follows: It will be assumed that the chisel head 14 is dissociated from the handle 12. In this position the fastener 34 is located within the aligned apertures 30 and 32 but is not tightened. In this portion the second leg 26 is non-parallel with respect to the first leg 24.

To connect the chisel head 14 to the handle 12, a person manually inserts the mating end 18 within the slot 28 of the connecting end 22. This insertion is to be such so that protuberance 64 cooperates with groove 52 and protuberance 66 cooperates with groove 54. The prongs 58 and 60 are inserted as far as possible within the slot 28 until the transverse protuberance 68 cooperates with the transverse groove 56. In this position the fastener 34 is located between the prongs 58 and 60.

The operator then through the use of a tool FIG. 7 effects tightening rotation of the fastener 34 by causing the tool to cooperate with the recess assembly 44. As this tightening procedure is effected the second leg 26 is caused to physically move toward the first leg 24. The amount of the movement of the second leg 26 is limited only by the inherent resiliency of the material of construction of the second leg 26 in the thickness of the second leg 26. On the drawing the non-parallel relationship of the second leg 26 with respect to the first leg

24 is exaggerated for purposes of description. This non-parallel relationship is only a few degrees so as to just facilitate ease of insertion of the mating end 18 into cooperation with the connecting end 22 so sufficient clearance is provided so that transverse protuberance 68 will be caused to cooperate within the groove 56.

The fastener 34 is tightened sufficiently so that adequate frictional binding of the prongs 58 and 60 occur between the legs 24 and 26. With the fastener 34 being sufficiently tightened, it is held in this position by the locking arrangement of the serrated surfaces 46 and 50.

As a result, accidental dislodgment of the chisel head 14 with respect to the handle 20 is prevented due to the positive locking arrangement of the serrated surfaces and also of the cooperation between the protuberances and their corresponding grooves. It has been found with the connecting arrangement between the chisel handle 12 and chisel blade 14 of this invention, that the chisel blade 14 will be retained in an extremely tight manner during an extended period of use without becoming loose with respect to the handle 12. The only time such will ever become loose is upon desiring to replace the chisel head 14 by manually loosening the fastener 34.

Normally the chisel 10 will be used in conjunction with a separate hammer. However, for better control of the hammering operation, a hammer element 19 may be incorporated within the handle 13 (FIG. 6). The handle 13 is formed into a cylindrical rod 21 upon which the element 19 is slidably mounted. The aft end of the handle 13 is connected to an enlarged knob 23 to prevent complete removal of element 19. The rod 21 is connected at its free end to connecting end 25. The base of the connecting end 25 is to be struck by the element 19 to achieve the hammering effect. The element 19 includes a recess 27 within its forward surface. The recess 27 is to matingly cooperate about the aft end of the connecting end 25.

The blades 14 may be constructed in an inexpensive manner to be disposable. Upon a blade 14 becoming dull, a new blade is inserted with the old blade discarded and used for scrap.

I claim:

1. A universal handle apparatus for surgical implements comprising:

a handle including a connecting end, said connecting end being bifurcated forming a first leg and a second leg, said legs in their natural state assuming a non-parallel relationship with respect to each other, the free end of said legs normally spaced further apart than said legs adjacent the apex of said bifurcation, whereby said legs assume said non-parallel relationship;

an implement head having a mating end adapted to cooperate with said connecting end;

a single fastener connectable between said first leg and said second leg, said fastener to be capable of securely retaining said mating end in cooperation with said connecting end, when said fastener is tightened said legs are moved to a substantially parallel relationship about said mating end; and

means formed on both said first leg and said second leg which cooperate to positively lock in place said implement head to said handle when said fastener is tightened.

2. Apparatus as defined in claim 1 wherein:

the free end of said legs normally spaced further apart than said legs adjacent the apex of said bifurcation, whereby said legs assume said non-parallel relationship.

3. Apparatus as defined in claim 1 wherein: said handle being elongated and having a longitudinal axis, said first leg being of a greater thickness than said second leg, said first leg being substantially parallel to said longitudinal axis, said second leg being normally non-parallel to said longitudinal axis, whereby upon said fastener being tightened said second leg is moved parallel to said longitudinal axis.

4. Apparatus as defined in claim 3 wherein: said fastener having an enlarged head, said enlarged head having a first serrated surface, one of said legs having a second serrated surface located adjacent its respective said aperture, said first and second serrated surfaces to cooperate to fix the tightened position of said fastener.

5. Apparatus as defined in claim 1 wherein: each of said legs having an aperture formed therein, said aperture being in alignment with each other, said fastener to cooperate with said apertures to move said legs in substantial parallel relationship thereby causing secure retention of said mating end between said legs.

6. Apparatus as defined in claim 5 wherein: said fastener and one of said legs cooperating in a screw threaded manner.

7. Apparatus as defined in claim 5 wherein: said fastener having an enlarged head, the head of said fastener having a central polygonal shaped recess, therebeing a plurality of slits extend from said recess in a radial manner.

8. Apparatus as defined in claim 1 wherein: said mating end having a pair of spaced apart elongated prongs, said fastener to be located between said prongs when retaining said mating end within said connecting end.

9. A universal handle apparatus for surgical implements comprising: a handle including a connecting end, said connecting end being bifurcated forming a first leg and a sec-

ond leg, said legs in their natural state assuming a non-parallel relationship with respect to each other;

an implement head having a mating end adapted to cooperate with said connecting end;

a single fastener connectable between said first leg and said second leg, said fastener to be capable of securely retaining said mating end in cooperation with said connecting end, when said fastener is tightened said legs are moved to a substantially parallel relationship about said mating end;

said mating end having a pair of spaced apart elongated prongs, said fastener to be located between said prongs when retaining said mating end within said connecting end; and

each of said prongs having an elongated protuberance, said connecting end having a pair of spaced apart elongated grooves, a said elongated protuberance to cooperate with a said elongated groove upon said mating end located within said connecting end.

10. Apparatus as defined in claim 9 wherein: said mating end further including a transverse protuberance, said connecting end having a transverse groove, said transverse protuberance to cooperate with said transverse groove upon said mating end located within said connecting end.

11. Apparatus as defined in claim 10 wherein: the free end of said legs is normally spaced further apart than said legs adjacent the apex of said bifurcation, whereby said legs assume said non-parallel relationship.

12. Apparatus as defined in claim 11 wherein: said handle being elongated and having a longitudinal axis, said first leg being of a greater thickness than said second leg, said first leg being substantially parallel to said elongated axis, said second leg being normally non-parallel to said longitudinal axis.

13. Apparatus as defined in claim 12 wherein: said elongated grooves and said transverse groove are formed within said first leg.

* * * * *

5

10

15

20

25

30

35

40

45

50

55

60

65