

M. WILLARD.
HOISTING MACHINE.

No. 47,761.

Patented May 16, 1865.

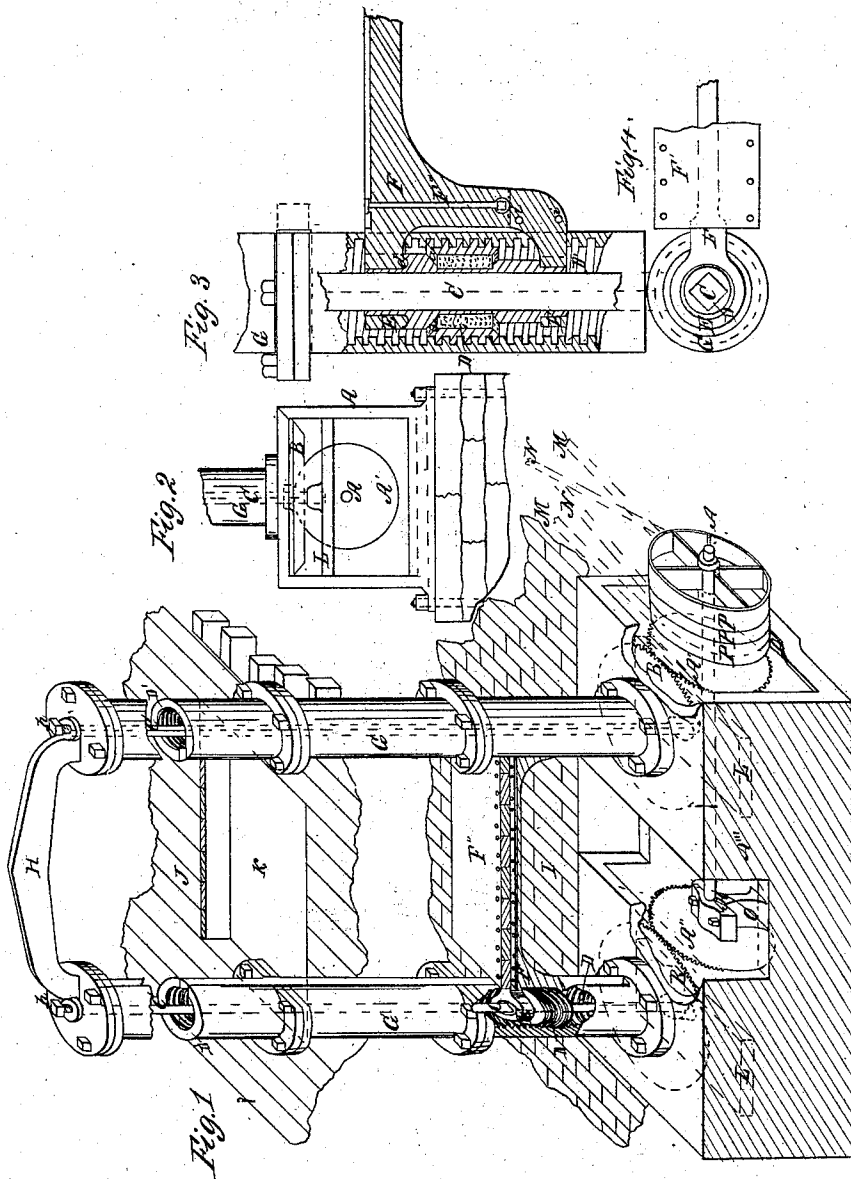

Witnesses:
R. C. Phillips
H. A. Clark

Inventor:
Morgan Willard

UNITED STATES PATENT OFFICE.

MORGAN WILLARD, OF CINCINNATI, OHIO.

IMPROVEMENT IN HOISTING-MACHINES.

Specification forming part of Letters Patent No. 47,761, dated May 16, 1865.

To all whom it may concern:

Be it known that I, MORGAN WILLARD, of Cincinnati, in the county of Hamilton and State of Ohio, have invented a new and useful machine for the purpose of hoisting weights, goods, and merchandise in warehouses, on steamboats, &c.; and I do hereby declare that the following is a full, clear, and exact description of the construction and operation of the same, reference being had to the annexed drawings, making a part of this specification, in which—

Figure 1 is a perspective view of the machine complete, together with a portion of the pavement or cellar floor and a section of one of the other floors of the store or other building in which it is located. Fig. 2 is an end view of the lower part of the machine, showing the stone or other foundation on which it rests, the bed-plate, housing, step-beam, &c. Fig. 3 is an enlarged section of the most important parts of my said machine. Fig. 4 is a plan of one of the columns.

The same letters refer to the same things in the several figures.

A A is the driving-shaft. A' and A'' are the two bevel wheels or pinions alike on the shaft A. B and B' are two other wheels which gear into A' and A'', and are hung on the square shafts or spindles C C. A''' is the cast-iron housing or frame in which the wheels A' A'' and B and B', the shaft A, the boxes or bearings *o o*, the bearers L L, with their steps for the spindles *c c* are located, and on which the columns G G stand; C C, two shafts or spindles, which I usually make of square iron, though they may be of other sections. They each have a journal or foot at their lower ends, which revolve in the steps L L. The wheels B and B' are secured on these shafts, as shown in Fig. 2. They extend upward through the center of the columns G G the entire height of the machine. They each have a journal at their upper end, with a collar resting on the upper side of the box, so that the rods *c c* are suspended on it, the bottom of the step at the lower end being below the foot of the shaft. They are prevented from lifting up by the two set-screws *h h*.

D is one of two worms or screws, (one in each column,) which have openings cast through them of such shape and size as to allow the shafts C C to slide freely, while at the same

time they fit it snugly. On the face of this the worm or thread is cut, so as to fit into and move up and down in the female screw or thread D', which is cut on the inside of the columns from end to end. There is a journal on the upper and lower ends of D, which fits the collars that form the connection between the worms D and the platform F F'. At the base or lower end of the upper journal of D the shoulder is turned out in a cup shape, as shown at *d d*, Fig. 3, to receive the convex lower face of the collar E. The lower journal is clasped in like manner by the collar E', as shown in Fig. 3. There is a blank space on D below the thread, of any desirable length, for the purpose of giving steadiness to the platform F, that is to prevent it from tipping and to allow D to be inserted into its place, the collar E being enlarged at the upper end and the collar E' being a box, with a cap, which is secured in position by two bolts inserted at *i i*, Fig. 3.

aa are two of four or more openings from the shoulder of D above the thread into a chamber cored out, as at *a' a'*, to be filled with cotton and oil. *a'' a''* are two of four or more openings from this chamber, through which the oil escapes to lubricate the thread in the columns. F is the frame (cast-iron) of the platform on which the articles are placed. F' in Fig. 4 is the flange upon which the frame or planking F'' is bolted. F''', Fig. 3, is one of four struts or braces which serve to keep the frame or planking F'' from tipping.

G G are the two columns which form the frame of the machine. They are cast hollow, and in sections of any convenient length, flanged at the ends, and fitted one to the other so as to form any required height. A segment of the flanges is cut off, as shown, to allow the frame or platform to pass, and a slot or opening is cut through the side next the platform, so as to allow the necks of the platform to pass into the collars E E' and slide up and down the whole height of the machine, as shown in the several figures.

I is a portion of the pavement or lower floor.

J is a portion of one of the upper floors.

K is the hatch or opening through which the platform passes.

M M and N N are open and crossed bands, which give direct and reverse motion to the shaft A through the fast pulley P', and allow

it to remain quiet when they are both on the loose pulleys P P.

The operation of my machine is as follows: Motion being given to A by means of one of the bands M M or N N, or by other means, is transmitted through the wheel A' A'' and B B' to the spindle C C, which in turn cause the worms D to revolve in the nuts D' D', thus causing D D to rise or fall, carrying with them the platform F F'. The motion is controlled by means of the ordinary trip-movement for the bands, with the required stops, &c.

The advantages of this machine consist mainly in its perfect safety; it cannot fall; its simplicity; it carries no dead weight, except the platform F F' and the worms D D;

its cheapness and durability, (which are very great,) and economy of power.

What I claim as my invention, and desire to secure by Letters Patent, is—

The hollow columns G G, with the continuous thread or screw D', and the continuous slots or openings in or through the sides of the said columns G G, extending throughout their length, in combination with the bolt or worm D, with the shaft or rod C, all arranged, actuated, and combined substantially as set forth and described.

MORGAN WILLARD.

Witnesses:

R. C. PHILLIPS,
H. N. CLARK.